

x550 Series

Stackable 10 Gigabit Intelligent Switches

The Allied Telesis x550 Series of stackable 10 Gigabit Layer 3 switches have capacity and resiliency coupled with easy management, meeting the needs of even the most demanding network core and distribution applications.



Overview

Allied Telesis x550 switches are high performing and feature-rich, making them the ideal choice for today's networks. They offer a range of versatile solutions for many different Enterprise applications.

Three models provide 16 x 1G/10G copper, 16 x 1G/10G SFP+ slots, or 8 x 1G/2.5G/5G/10G copper and 8 x 1G/10G SFP+ slots, all with two 40G uplinks. With the power of Allied Telesis Virtual Chassis Stacking (VCStack™), the x550 Series is ideal for the network core, and demanding distribution applications.

Powerful network management

Allied Telesis Autonomous Management Framework™ (AMF) automates many everyday tasks including configuration management, to ease the workload of modern converged networks. The entire network can be managed as a single virtual device with powerful centralized features.

Network expansion is effortless with plug-and-play simplicity, and network node recovery is fully zero-touch. AMF Guestnode allows third party devices, such as IP phones and security cameras, to be part of an AMF network.

Resiliency

Converging network services means increasing demand for highly available networks with minimal downtime. VCStack, in conjunction with link aggregation, provides a network with no single point of failure, and provides access application resiliency.

Ethernet Protection Switched Ring (EPSRing™), and the standards-based

G.8032 Ethernet Ring Protection, ensure distributed networks have high-speed access to online resources and applications.

The x550 Series can form a VCStack of up to four units for enhanced resiliency and simplified device management. Stacking links can use any port speed, so the stack can be configured to suit specific needs.

Long distance stacking (VCStack LD), which enables stacks to be created over long distance fiber links, combines with full EPSRing support to make the x550 Series the perfect choice for distributed environments too.

High-speed wireless

The spread of high-speed wireless (802.11ac or "Wave2") is problematic for network infrastructure. Unless the infrastructure is upgraded to cope with increased speeds, it creates a bottleneck which negatively impacts the effectiveness of the wireless network. But increasing speeds from 1 Gigabit has traditionally meant moving to 10 Gigabit. This requires new cabling, which is expensive and time consuming to install.

The x550-18XSPQm solves these issues because it provides support for 2.5 and 5 Gigabit. At this speed, the wireless network runs at full capacity, and there is no need to replace existing Cat5E and Cat6 cables.

Secure

A secure network environment is guaranteed. The x550 Series offers powerful control over network traffic types, secure management options, loop guard to protect against cabling mistakes, and tri-authentication for comprehensive access control.



Future-proof

The x550 Series ensures a future-proof network, with superior flexibility coupled with the ability to stack multiple units. All x550 Series models feature 40 Gigabit uplinks ports, and support OpenFlow and a comprehensive IPv6 feature set, to ensure they are ready for SDN and future network traffic demands.

Environmentally friendly

The x550 Series supports Energy Efficient Ethernet (EEE), automatically reducing the power consumed by the switch whenever there is no traffic on a port. This sophisticated feature can significantly reduce operating costs by reducing the power requirements of the switch and any associated cooling equipment.



New/Key Features

- ▶ Autonomous Management Framework (AMF) Master
- ▶ Continuous PoE
- ▶ 40G uplinks
- ▶ Stack using any port speed
- ▶ 4 x 10G breakout cables for 40G ports
- ▶ 2.5G for high-speed wireless applications
- ▶ OpenFlow v1.3
- ▶ G.8032 Ethernet Ring Protection
- ▶ Precision Time Protocol (PTP) Transparent Mode

Key Features

Allied Telesis Autonomous Management Framework (AMF)

- ▶ Allied Telesis Autonomous Management Framework (AMF) is a sophisticated suite of management tools that provide a simplified approach to network management. Powerful features like centralized management, auto-backup, auto-upgrade, auto-provisioning and auto-recovery enable plug-and-play networking and zero-touch management.
- ▶ Any x550 Series switch can operate as the AMF network master, storing firmware and configuration backups for other network nodes. The AMF master enables auto-provisioning and auto-upgrade by providing appropriate files to new network members. New network devices can be pre-provisioned making installation easy because no on-site configuration is required.
- ▶ AMF Guestnode allows Allied Telesis wireless access points and further switching products, as well as third party devices such as IP phones and security cameras, to be part of an AMF network.

Virtual Chassis Stacking (VCStack)

- ▶ Create a VCStack of up to four units with 160 Gbps of stacking bandwidth to each unit. Stacking links are connected in a ring so each device has dual connections to further improve resiliency. VCStack provides a highly available system where network resources are spread out across stacked units, reducing the impact if one of the units fails. Aggregating switch ports on different units across the stack provides excellent network resiliency.

Flexible Deployment

- ▶ The compact x550-18XTQ and x550-18XSQ enable easy deployment, and 2 units can be installed side-by-side in 1RU, saving valuable rack space. VCStack enables a single 32-port 1RU virtual unit with built in resiliency.

Long-Distance Stacking (VCStack-LD)

- ▶ Long-distance stacking allows a VCStack to be created over longer distances, perfect for a distributed network environment.

Ethernet Protection Switched Ring (EPSRing)

- ▶ EPSRing and 10 Gigabit Ethernet allow several x550 switches to form high-speed protected rings capable of recovery within as little as 50ms. This feature is perfect for high performance and high availability in enterprise networks.

G.8032 Ethernet Ring Protection

- ▶ G.8032 provides standards-based high-speed ring protection, that can be deployed stand-alone, or interoperate with Allied Telesis EPSR.
- ▶ Ethernet Connectivity Fault Monitoring (CFM) proactively monitors links and VLANs, and provides alerts when a fault is detected.

Industry-leading Quality of Service (QoS)

- ▶ Comprehensive low-latency wire speed QoS provides flow-based traffic management with full classification, prioritization, traffic shaping and min/max bandwidth profiles. Boosted network

performance and guaranteed delivery of business-critical Ethernet services and applications are provided. Time-critical services such as voice and video take precedence over non-essential services such as file downloads, maintaining responsiveness of Enterprise applications.

Loop Protection

- ▶ Thrash limiting, also known as rapid MAC movement, detects and resolves network loops. It is highly user-configurable — from the rate of looping traffic to the type of action the switch should take when it detects a loop.
- ▶ With thrash limiting, the switch only detects a loop when a storm has occurred, which can potentially cause disruption to the network. To avoid this, loop detection works in conjunction with thrash limiting to send special Loop Detection Frame (LDF) packets that the switch listens for. If a port receives an LDF packet, you can choose to disable the port, disable the link, or send an SNMP trap. This feature can help to detect loops before a network storm occurs, avoiding the risk and inconvenience of traffic disruption.

Power over Ethernet Plus (PoE+)

- ▶ With PoE, a separate power connection to media endpoints such as IP phones and wireless access points is not necessary. PoE+ reduces costs and provides even greater flexibility, providing the capability to connect devices requiring more power (up to 30 Watts) such as pan, tilt and zoom security cameras.

Continuous PoE

- ▶ Continuous PoE allows the switch to be restarted without affecting the supply of power to connected devices. Smart lighting, security cameras, and other PoE devices will continue to operate during a software upgrade on the switch.

Voice VLAN

- ▶ Voice VLAN automatically separates voice and data traffic into two different VLANs. This automatic separation places delay-sensitive traffic into a voice- dedicated VLAN, which simplifies QoS configurations.

Open Shortest Path First (OSPFv3)

- ▶ OSPF is a scalable and adaptive routing protocol for IP networks. The addition of OSPFv3 adds support for IPv6 and further strengthens the Allied Telesis focus on next generation networking.

sFlow

- ▶ sFlow is an industry-standard technology for monitoring high-speed switched networks. It provides complete visibility into network use, enabling performance optimization, usage accounting/billing, and defense against security threats. Sampled packets sent to a collector ensure it always has a real-time view of network traffic.

VLAN Mirroring (RSPAN)

- ▶ VLAN mirroring allows traffic from a port on a remote switch to be analyzed locally. Traffic being transmitted or received on the port is duplicated and sent across the network on a special VLAN.

Optical DDM

- ▶ Most modern optical SFP/SFP+/XFP transceivers support Digital Diagnostics Monitoring (DDM) functions according to the specification SFF-8472. This enables real time monitoring of the various parameters of the transceiver, such as optical output power, temperature, laser bias current and transceiver supply voltage. Easy access to this information simplifies diagnosing problems with optical modules and fiber connections.

Active Fiber Monitoring

- ▶ Active Fiber Monitoring prevents eavesdropping on fiber communications by monitoring received optical power. If an intrusion is detected, the link can be automatically shut down, or an operator alert can be sent. Active Fiber Monitoring is supported on fiber data and fiber stacking links.

Tri-authentication

- ▶ Authentication options on the x550 Series also include alternatives to IEEE 802.1x port-based authentication, such as web authentication, to enable guest access and MAC authentication for endpoints that do not have an IEEE 802.1x supplicant. All three authentication methods— IEEE 802.1x, MAC-based and Web-based— can be enabled simultaneously on the same port for tri-authentication.

TACACS+ Command Authorization

- ▶ Centralize control of which commands may be issued by a specific user of an AlliedWare Plus device. TACACS+ command authorization complements authentication and accounting services for a complete AAA solution

Premium Software License

- ▶ By default, the x550 Series offers a comprehensive Layer 2 and basic Layer 3 feature set that includes static routing and IPv6 management features. The feature set can easily be elevated to full Layer 3 by applying the premium software license. This adds dynamic routing protocols and Layer 3 multicasting capabilities.

VLAN ACLs

- ▶ Simplify access and traffic control across entire segments of the network. Access Control Lists (ACLs) can be applied to a Virtual LAN (VLAN) as well as a specific port.

Software Defined Networking (SDN)

- ▶ OpenFlow is a key technology that enables the use of SDN to build smart applications that unlock value and reduce cost.

Precision Time Protocol (PTP)

- ▶ PTP (IEEE 1588v2) synchronizes clocks throughout the network with micro-second accuracy, supporting industrial automation and control systems.

Multi-speed Ports

- ▶ Copper ports on the x550-18XSPQm support 2.5 and 5 Gigabit connectivity to enable high-speed wireless, and the use of legacy Cat5E/6 cabling.

Key Solutions

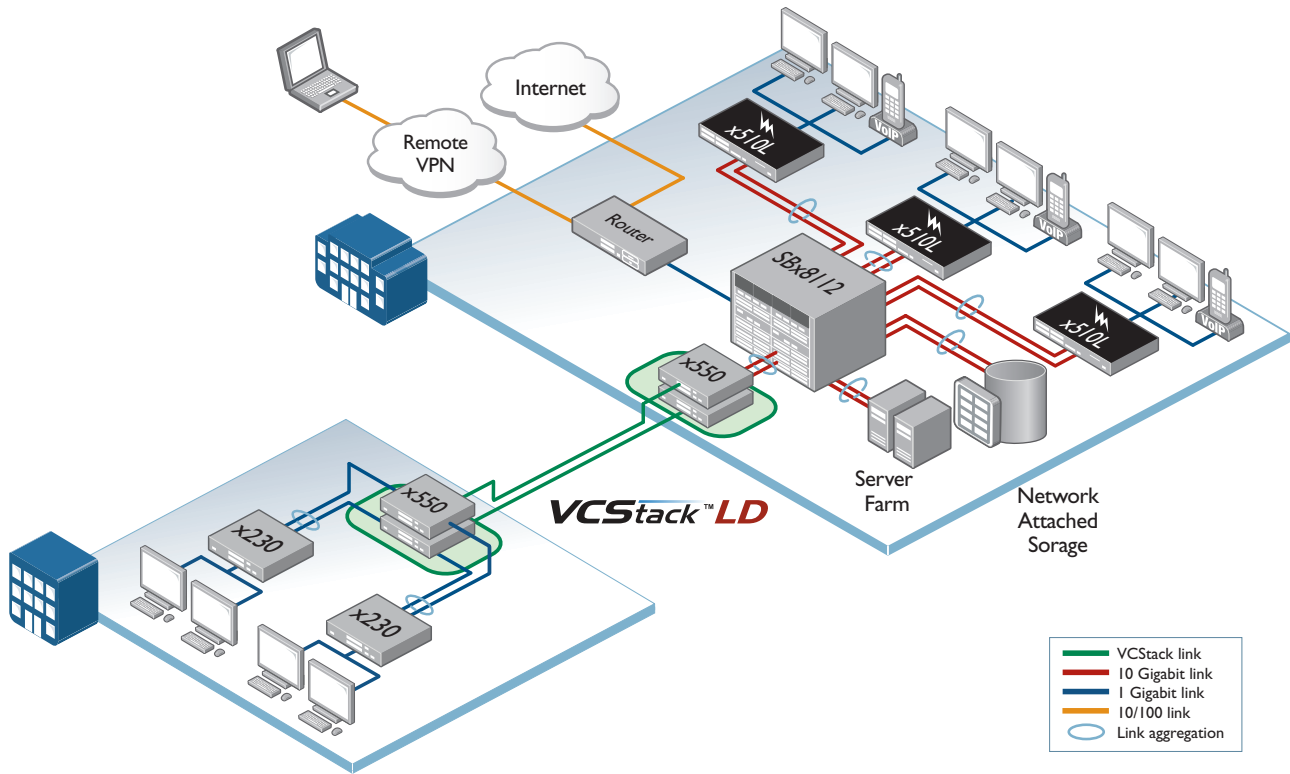

Resilient distribution switching

Allied Telesis x550 Series switches are ideal for distribution solutions, where resiliency and flexibility are required. In the above diagram, distribution switches utilize long-distance Virtual Chassis Stacking (VCStack-LD) to create a single virtual unit out of multiple devices. By using fiber stacking connectivity, units can be kilometers apart—perfect for a distributed environment.

When combined with link aggregation, VCStack provides a solution with no single point of failure, and which fully utilizes all available network bandwidth.

x550 switches provide a resilient and reliable distribution solution to support all networks with business-critical online resources and applications.

Key Solutions

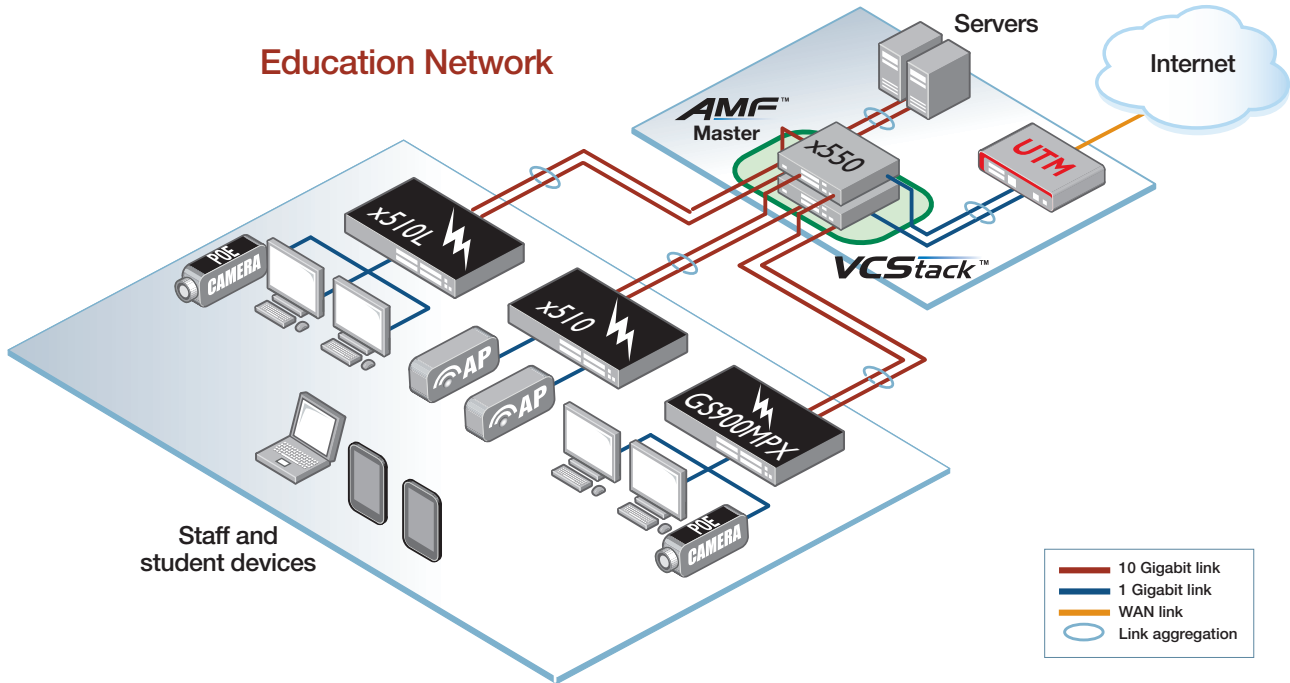

Resilient network core

x550 switches have the power of Virtual Chassis Stacking (VCStack), which removes any single point of failure from the network—making them perfect for small business or education solutions.

The diagram shows a pair of x550 switches in an education environment, with link aggregation between the core VCStack and servers, the firewall, and edge switches to provide resilient connectivity.

Allied Telesis edge switches connect and power access points for wireless network connectivity for staff and students, as well as IP security cameras to ensure a safe learning environment.

Autonomous Management Framework (AMF) simplifies and automates many day to day administration tasks, easing the burden of network management. The x550 switches act as the AMF master, automatically backing up the entire network, and providing plug-and-play network growth and zero-touch unit replacement.

Specifications

PRODUCT	1G/10G (RJ-45) COPPER PORTS	1G/2.5G/5G/10G (RJ-45) COPPER PORTS	1G/10G SFP+ PORTS	40G QSFP PORTS	MAX POE+ ENABLED PORTS	SWITCHING FABRIC	FORWARDING RATE
x550-18XTQ	16	-	-	2	-	480Gbps	357.1Mpps
x550-18XSQ	-	-	16	2	-	480Gbps	357.1Mpps
x550-18XSPQm	-	8	8	2	8	480Gbps	357.1Mpps

Performance

- ▶ 160Gbps of stacking bandwidth
- ▶ Supports jumbo frames
 - 12.3KB at 1G, 10G, 40G
 - 6.5KB at 2.5G
 - 10.0KB at 5G
- ▶ Wirespeed multicasting
- ▶ 4094 configurable VLANs
- ▶ Up to 16K MAC addresses
- ▶ Up to 256 multicast entries
- ▶ 1024MB DDR SDRAM, 1024MB flash memory
- ▶ Packet buffer memory: 4MB

Reliability

- ▶ Modular AlliedWare Plus™ operating system
- ▶ Full environmental monitoring of PSUs, fans, temperature and internal voltages. SNMP traps alert network managers in case of any failure

Power Characteristics

- ▶ AC voltage: 90 to 260V (auto-ranging)
- ▶ Frequency: 47 to 63Hz

Expandability

- ▶ Stack up to four units in a VCStack
- ▶ Premium license option for additional features

Flexibility and Compatibility

- ▶ 10G SFP+ ports will support any combination of Allied Telesis 1000Mbps SFP and 10GbE SFP+ modules and direct attach cables listed in this document under Ordering Information
- ▶ Stacking ports can be configured from 10G or 40G ports
- ▶ Port speed and duplex configuration can be set manually or by auto-negotiation

Diagnostic Tools

- ▶ Active Fiber Monitoring detects tampering on optical links
- ▶ Built-In Self Test (BIST)
- ▶ Cable fault locator (TDR)
- ▶ Find-me device locator
- ▶ Automatic link flap detection and port shutdown
- ▶ Optical Digital Diagnostic Monitoring (DDM)
- ▶ Ping polling for IPv4 and IPv6
- ▶ Port mirroring
- ▶ TraceRoute for IPv4 and IPv6
- ▶ Uni-Directional Link Detection (UDLD)

IPv4 Features

- ▶ Black hole routing
- ▶ Directed broadcast forwarding
- ▶ DNS relay
- ▶ Equal Cost Multi Path (ECMP) routing
- ▶ Policy-based routing
- ▶ Route redistribution (OSPF, RIP, BGP)

- ▶ Static unicast and multicast routing for IPv4
- ▶ UDP broadcast helper (IP helper)

IPv6 Features

- ▶ DHCPv6 client and relay
- ▶ DNSv6 client and relay
- ▶ IPv4 and IPv6 dual stack
- ▶ IPv6 aware storm protection and QoS
- ▶ IPv6 hardware ACLs
- ▶ Device management over IPv6 networks with SNMPv6, Telnetv6 and SSHv6
- ▶ NTPv6 client and server
- ▶ Static unicast and multicast routing for IPv6
- ▶ Log to IPv6 hosts with Syslog v6

Management

- ▶ Front panel 7-segment LED provides at-a-glance status and fault information
- ▶ Allied Telesis Autonomous Management Framework (AMF) enables powerful centralized management and zero-touch device installation and recovery
- ▶ Console management port on the front panel for ease of access
- ▶ Eco-friendly mode allows ports and LEDs to be disabled to save power
- ▶ Web-based Graphical User Interface (GUI)
- ▶ Industry-standard CLI with context-sensitive help
- ▶ Powerful CLI scripting engine
- ▶ Comprehensive SNMP MIB support for standards-based device management
- ▶ Built-in text editor
- ▶ Event-based triggers allow user-defined scripts to be executed upon selected system events
- ▶ USB interface allows software release files, configurations and other files to be stored for backup and distribution to other devices

Quality of Service

- ▶ 8 priority queues with a hierarchy of high priority queues for real time traffic, and mixed scheduling, for each switch port
- ▶ Limit bandwidth per port or per traffic class down to 64kbps
- ▶ Wirespeed traffic classification with low latency essential for VoIP and real-time streaming media applications
- ▶ IPv6 QoS support
- ▶ Policy-based QoS based on VLAN, port, MAC and general packet classifiers
- ▶ Policy-based storm protection
- ▶ Extensive remarking capabilities
- ▶ Taildrop for queue congestion control
- ▶ Queue scheduling options for strict priority, weighted round robin or mixed scheduling
- ▶ Type of Service (ToS) IP precedence and DiffServ marking based on layer 2, 3 and 4 headers

Resiliency Features

- ▶ Control Plane Prioritization (CPP) ensures the CPU always has sufficient bandwidth to process network control traffic
- ▶ Dynamic link failover (host attach)
- ▶ EPSRing (Ethernet Protection Switched Rings) with SuperLoop Protection (SLP) and enhanced recovery for extra resiliency
- ▶ Flexi-stacking - use any port speed to stack: 10G fiber, 10G copper or 40G fiber
- ▶ Long-Distance VCStack over fiber with 10G SFP+ modules or 40G QSFP+ modules (LD-VCStack)
- ▶ Loop protection: loop detection and thrash limiting
- ▶ PVST+ compatibility mode
- ▶ STP root guard
- ▶ VCStack fast failover minimizes network disruption

Security Features

- ▶ Access Control Lists (ACLs) based on layer 3 and 4 headers
- ▶ Auth fail and guest VLANs
- ▶ Authentication, Authorisation and Accounting (AAA)
- ▶ Bootloader can be password protected for device security
- ▶ BPDU protection
- ▶ DHCP snooping, IP source guard and Dynamic ARP Inspection (DAI)
- ▶ DoS attack blocking and virus throttling
- ▶ Dynamic VLAN assignment
- ▶ MAC address filtering and MAC address lock-down
- ▶ Network Access and Control (NAC) features manage endpoint security
- ▶ Port-based learn limits (intrusion detection)
- ▶ Private VLANs provide security and port isolation for multiple customers using the same VLAN
- ▶ Secure Copy (SCP)
- ▶ Secure File Transfer Protocol (SFTP) client
- ▶ Strong password security and encryption
- ▶ Tri-authentication: MAC-based, web-based and IEEE 802.1x
- ▶ Web-based authentication

Software Defined Networking

- ▶ OpenFlow v1.3 including support for connection interruption, control plane encryption and inactivity probe

Environmental Specifications

- ▶ Operating temperature range: 0°C to 45°C (32°F to 113°F)
Derated by 1°C per 305 meters (1,000 ft)
- ▶ Storage temperature range: -25°C to 70°C (-13°F to 158°F)
- ▶ Operating relative humidity range: 5% to 90% non-condensing
- ▶ Storage relative humidity range: 5% to 95% non-condensing
- ▶ Operating altitude: 3,048 meters maximum (10,000 ft)

Electrical Approvals and Compliances

- ▶ EMC: EN55022 class A, FCC class A, VCCI class A, ICES-003 class A
- ▶ Immunity: EN55024, EN61000-3-levels 2 (Harmonics), and 3 (Flicker) – AC models only

Safety

- ▶ Standards: UL60950-1, CAN/CSA-C22.2 No. 60950-1-03, EN60950-1, EN60825-1, AS/NZS 60950.1
- ▶ Certification: UL, cUL, TUV

Restrictions on Hazardous Substances (RoHS) Compliance

- ▶ EU RoHS compliant
- ▶ China RoHS compliant

Country of Origin

- ▶ Indonesia

Physical Specifications

PRODUCT	WIDTH	DEPTH	HEIGHT	WEIGHT
x550-18XTQ	210 mm (8.3 in)	346 mm (13.6 in)	44 mm (1.7 in)	3.1 kg (6.85 lb)
x550-18XSQ	210 mm (8.3 in)	346 mm (13.6 in)	44 mm (1.7 in)	3.2 kg (7.00 lb)
x550-18XSPQm	440 mm (17.3 in)	260 mm (10.2 in)	44 mm (1.7 in)	4.2 kg (9.15 lb)

Power Characteristics

90-260VAC auto ranging, 47-63Hz

PRODUCT	NO POE LOAD			FULL POE+ LOAD			MAX POE POWER	MAX POE+ PORTS AT 30W PER PORT
	MAX POWER CONSUMPTION	MAX HEAT DISSIPATION	NOISE	MAX POWER CONSUMPTION	MAX HEAT DISSIPATION	NOISE		
x550-18XTQ	128W	436 BTU/h	50 dBA	-	-	-	-	-
x550-18XSQ	111W	378 BTU/h	46 dBA	-	-	-	-	-
x550-18XSPQm	99W	338 BTU/h	47 dBA	391W	1334 BTU/h	47 dBA	240W	8

Latency (Microseconds)

PRODUCT	PORT SPEED		
	1GBPS	10GBPS	40GBPS
x550-18XTQ	3.9µs	3.0µs	2.2µs
x550-18XSQ	3.9µs	3.0µs	2.2µs
x550-18XSPQm	3.8µs	3.0µs	2.3µs

Standards and Protocols

AlliedWare Plus Operating System

Version 5.4.8-1

Authentication

- RFC 1321 MD5 Message-Digest algorithm
- RFC 1828 IP authentication using keyed MD5

Border Gateway Protocol (BGP)

- BGP dynamic capability
- BGP outbound route filtering
- RFC 1772 Application of the Border Gateway Protocol (BGP) in the Internet
- RFC 1997 BGP communities attribute
- RFC 2385 Protection of BGP sessions via the TCP MD5 signature option
- RFC 2439 BGP route flap damping
- RFC 2545 Use of BGP-4 multiprotocol extensions for IPv6 inter-domain routing
- RFC 2858 Multiprotocol extensions for BGP-4
- RFC 2918 Route refresh capability for BGP-4
- RFC 3392 Capabilities advertisement with BGP-4
- RFC 3882 Configuring BGP to block Denial-of-Service (DoS) attacks
- RFC 4271 Border Gateway Protocol 4 (BGP-4)
- RFC 4360 BGP extended communities
- RFC 4456 BGP route reflection - an alternative to full mesh iBGP
- RFC 4724 BGP graceful restart

- RFC 4893 BGP support for four-octet AS number space
- RFC 5065 Autonomous system confederations for BGP

Cryptographic Algorithms

FIPS Approved Algorithms

- Encryption (Block Ciphers):
 - ▶ AES (ECB, CBC, CFB and OFB Modes)
 - ▶ 3DES (ECB, CBC, CFB and OFB Modes)
 - Block Cipher Modes:
 - ▶ CCM, CMAC, GCM, XTS
 - Digital Signatures & Asymmetric Key Generation:
 - ▶ DSA, ECDSA, RSA
 - Secure Hashing:
 - ▶ SHA-1
 - ▶ SHA-2 (SHA-224, SHA-256, SHA-384, SHA-512)
 - Message Authentication:
 - ▶ HMAC (SHA-1, SHA-2(224, 256, 384, 512))
 - Random Number Generation:
 - ▶ DRBG (Hash, HMAC and Counter)
- Non FIPS Approved Algorithms**
- RNG (AES128/192/256)
 - DES
 - MD5

Ethernet

- IEEE 802.2 Logical Link Control (LLC)
- IEEE 802.3 Ethernet

- IEEE 802.3ab1000BASE-T
- IEEE 802.3ae10 Gigabit Ethernet
- IEEE 802.3af Power over Ethernet (PoE)
- IEEE 802.3an10GBASE-T
- IEEE 802.3at Power over Ethernet Plus (PoE+)
- IEEE 802.3azEnergy Efficient Ethernet (EEE)
- IEEE 802.3ba40GBASE-X
- IEEE 802.3bz2.5GBASE-T and 5GBASE-T
- IEEE 802.3x Flow control - full-duplex operation
- IEEE 802.3z 1000BASE-X
- IEEE 1588v2 Precision clock synchronization protocol v2

IPv4 Features

- RFC 768 User Datagram Protocol (UDP)
- RFC 791 Internet Protocol (IP)
- RFC 792 Internet Control Message Protocol (ICMP)
- RFC 793 Transmission Control Protocol (TCP)
- RFC 826 Address Resolution Protocol (ARP)
- RFC 894 Standard for the transmission of IP datagrams over Ethernet networks
- RFC 919 Broadcasting Internet datagrams
- RFC 922 Broadcasting Internet datagrams in the presence of subnets
- RFC 932 Subnetwork addressing scheme
- RFC 950 Internet standard subnetting procedure
- RFC 951 Bootstrap Protocol (BootP)
- RFC 1027 Proxy ARP
- RFC 1035 DNS client
- RFC 1042 Standard for the transmission of IP datagrams over IEEE 802 networks

RFC 1071	Computing the Internet checksum
RFC 1122	Internet host requirements
RFC 1191	Path MTU discovery
RFC 1256	ICMP router discovery messages
RFC 1518	An architecture for IP address allocation with CIDR
RFC 1519	Classless Inter-Domain Routing (CIDR)
RFC 1542	Clarifications and extensions for BootP
RFC 1591	Domain Name System (DNS)
RFC 1812	Requirements for IPv4 routers
RFC 1918	IP addressing
RFC 2581	TCP congestion control

IPv6 Features

RFC 1981	Path MTU discovery for IPv6
RFC 2460	IPv6 specification
RFC 2464	Transmission of IPv6 packets over Ethernet networks
RFC 3484	Default address selection for IPv6
RFC 3587	IPv6 global unicast address format
RFC 3596	DNS extensions to support IPv6
RFC 4007	IPv6 scoped address architecture
RFC 4193	Unique local IPv6 unicast addresses
RFC 4213	Transition mechanisms for IPv6 hosts and routers
RFC 4291	IPv6 addressing architecture
RFC 4443	Internet Control Message Protocol (ICMPv6)
RFC 4861	Neighbor discovery for IPv6
RFC 4862	IPv6 Stateless Address Auto-Configuration (SLAAC)
RFC 5014	IPv6 socket API for source address selection
RFC 5095	Deprecation of type 0 routing headers in IPv6
RFC 5175	IPv6 Router Advertisement (RA) flags option
RFC 6105	IPv6 Router Advertisement (RA) guard

Management

AMF MIB and SNMP traps	
AT Enterprise MIB	
SNMPv1, v2c and v3	
IEEE 802.1ABLink Layer Discovery Protocol (LLDP)	
RFC 1155	Structure and identification of management information for TCP/IP-based Internets
RFC 1157	Simple Network Management Protocol (SNMP)
RFC 1212	Concise MIB definitions
RFC 1213	MIB for network management of TCP/IP-based Internets: MIB-II
RFC 1215	Convention for defining traps for use with the SNMP
RFC 1227	SNMP MUX protocol and MIB
RFC 1239	Standard MIB
RFC 1724	RIPv2 MIB extension
RFC 2578	Structure of Management Information v2 (SMIv2)
RFC 2579	Textual conventions for SMIv2
RFC 2580	Conformance statements for SMIv2
RFC 2674	Definitions of managed objects for bridges with traffic classes, multicast filtering and VLAN extensions
RFC 2741	Agent extensibility (AgentX) protocol
RFC 2787	Definitions of managed objects for VRRP
RFC 2819	RMON MIB (groups 1,2,3 and 9)
RFC 2863	Interfaces group MIB
RFC 3176	sFlow: a method for monitoring traffic in switched and routed networks
RFC 3411	An architecture for describing SNMP management frameworks
RFC 3412	Message processing and dispatching for the SNMP
RFC 3413	SNMP applications
RFC 3414	User-based Security Model (USM) for SNMPv3
RFC 3415	View-based Access Control Model (VACM) for SNMP
RFC 3416	Version 2 of the protocol operations for the SNMP
RFC 3417	Transport mappings for the SNMP
RFC 3418	MIB for SNMP
RFC 3635	Definitions of managed objects for the Ethernet-like interface types

RFC 3636	IEEE 802.3 MAU MIB
RFC 4022	MIB for the Transmission Control Protocol (TCP)
RFC 4113	MIB for the User Datagram Protocol (UDP)
RFC 4188	Definitions of managed objects for bridges
RFC 4292	IP forwarding table MIB
RFC 4293	MIB for the Internet Protocol (IP)
RFC 4318	Definitions of managed objects for bridges with RSTP
RFC 4560	Definitions of managed objects for remote ping, traceroute and lookup operations
RFC 5424	Syslog protocol
RFC 6527	Definitions of managed objects for VRRPv3

Multicast Support

Bootstrap Router (BSR) mechanism for PIM-SM	
IGMP query solicitation	
IGMP snooping (IGMPv1, v2 and v3)	
IGMP snooping fast-leave	
IGMP/MLD multicast forwarding (IGMP/MLD proxy)	
MLD snooping (MLDv1 and v2)	
PIM for IPv6 and PIM SSM for IPv6	
RFC 1112	Host extensions for IP multicasting (IGMPv1)
RFC 2236	Internet Group Management Protocol v2 (IGMPv2)
RFC 2710	Multicast Listener Discovery (MLD) for IPv6
RFC 2715	Interoperability rules for multicast routing protocols
RFC 3306	Unicast-prefix-based IPv6 multicast addresses
RFC 3376	IGMPv3
RFC 3810	Multicast Listener Discovery v2 (MLDv2) for IPv6
RFC 3956	Embedding the Rendezvous Point (RP) address in an IPv6 multicast address
RFC 3973	PIM Dense Mode (DM)
RFC 4541	IGMP and MLD snooping switches
RFC 4601	Protocol Independent Multicast - Sparse Mode (PIM-SM): protocol specification (revised)
RFC 4604	Using IGMPv3 and MLDv2 for source-specific multicast
RFC 4607	Source-specific multicast for IP

Open Shortest Path First (OSPF)

OSPF link-local signaling	
OSPF MD5 authentication	
Out-of-band LSDB resync	
RFC 1245	OSPF protocol analysis
RFC 1246	Experience with the OSPF protocol
RFC 1370	Applicability statement for OSPF
RFC 1765	OSPF database overflow
RFC 2328	OSPFv2
RFC 2370	OSPF opaque LSA option
RFC 2740	OSPFv3 for IPv6
RFC 3101	OSPF Not-So-Stubby Area (NSSA) option
RFC 3509	Alternative implementations of OSPF area border routers
RFC 3623	Graceful OSPF restart
RFC 3630	Traffic engineering extensions to OSPF
RFC 4552	Authentication/confidentiality for OSPFv3
RFC 5329	Traffic engineering extensions to OSPFv3\
RFC 5340	OSPFv3 for IPv6 (partial support)

Quality of Service (QoS)

IEEE 802.1p	Priority tagging
RFC 2211	Specification of the controlled-load network element service
RFC 2474	DiffServ precedence for eight queues/port
RFC 2475	DiffServ architecture
RFC 2597	DiffServ Assured Forwarding (AF)
RFC 2697	A single-rate three-color marker
RFC 2698	A two-rate three-color marker
RFC 3246	DiffServ Expedited Forwarding (EF)

Resiliency Features

IEEE 802.1AXLink aggregation (static and LACP)	
IEEE 802.1D	MAC bridges
IEEE 802.1s	Multiple Spanning Tree Protocol (MSTP)
IEEE 802.1w	Rapid Spanning Tree Protocol (RSTP)

IEEE 802.3adStatic and dynamic link aggregation	
RFC 5798	Virtual Router Redundancy Protocol version 3 (VRRPv3) for IPv4 and IPv6

Security Features

SSH remote login	
SSLv2 and SSLv3	
TACACS+ Accounting, Authentication, Authorization (AAA)	
IEEE 802.1X	authentication protocols (TLS, TTLS, PEAP and MD5)
IEEE 802.1X	multi-supplicant authentication
IEEE 802.1X	port-based network access control
RFC 2560	X.509 Online Certificate Status Protocol (OCSP)
RFC 2818	HTTP over TLS ("HTTPS")
RFC 2865	RADIUS authentication
RFC 2866	RADIUS accounting
RFC 2868	RADIUS attributes for tunnel protocol support
RFC 2986	PKCS #10: certification request syntax specification v1.7
RFC 3546	Transport Layer Security (TLS) extensions
RFC 3579	RADIUS support for Extensible Authentication Protocol (EAP)
RFC 3580	IEEE 802.1x RADIUS usage guidelines
RFC 3748	PPP Extensible Authentication Protocol (EAP)
RFC 4251	Secure Shell (SSHv2) protocol architecture
RFC 4252	Secure Shell (SSHv2) authentication protocol
RFC 4253	Secure Shell (SSHv2) transport layer protocol
RFC 4254	Secure Shell (SSHv2) connection protocol
RFC 5246	Transport Layer Security (TLS) v1.2
RFC 5280	X.509 certificate and Certificate Revocation List (CRL) profile
RFC 5425	Transport Layer Security (TLS) transport mapping for Syslog
RFC 5656	Elliptic curve algorithm integration for SSH
RFC 6125	Domain-based application service identity within PKI using X.509 certificates with TLS
RFC 6614	Transport Layer Security (TLS) encryption for RADIUS
RFC 6668	SHA-2 data integrity verification for SSH

Services

RFC 854	Telnet protocol specification
RFC 855	Telnet option specifications
RFC 857	Telnet echo option
RFC 858	Telnet suppress go ahead option
RFC 1091	Telnet terminal-type option
RFC 1350	Trivial File Transfer Protocol (TFTP)RFC 1985 SMTP service extension
RFC 2049	MIME
RFC 2131	DHCPv4 (server, relay and client)
RFC 2132	DHCP options and BootP vendor extensions
RFC 2616	Hypertext Transfer Protocol - HTTP/1.1
RFC 2821	Simple Mail Transfer Protocol (SMTP)
RFC 2822	Internet message format
RFC 3046	DHCP relay agent information option (DHCP option 82)
RFC 3315	DHCPv6 (server, relay and client)
RFC 3633	IPv6 prefix options for DHCPv6
RFC 3646	DNS configuration options for DHCPv6
RFC 3993	Subscriber-ID suboption for DHCP relay agent option
RFC 4330	Simple Network Time Protocol (SNTP) version 4
RFC 5905	Network Time Protocol (NTP) version 4

VLAN Support

Generic VLAN Registration Protocol (GVRP)	
IEEE 802.1ad Provider bridges (VLAN stacking, Q-in-Q)	
IEEE 802.1Q Virtual LAN (VLAN) bridges	
IEEE 802.1v VLAN classification by protocol and port	
IEEE 802.3acVLAN tagging	

Voice over IP (VoIP)

LLDP-MED	ANSI/TIA-1057
Voice VLAN	

Ordering Information

Feature Licenses

NAME	DESCRIPTION	INCLUDES	STACK LICENSING
AT-FL-x550-01	x550 premium license	<ul style="list-style-type: none"> ▶ BGP4 (256 routes) ▶ RIP (256 routes) ▶ OSPF (256 routes) ▶ PIMv4-SM, DM and SSM ▶ EPPSR master ▶ VLAN double tagging (Q-in-Q) ▶ RIPng (256 routes) ▶ OSPFv3 (256 routes) ▶ MLDv1 and v2 ▶ PIMv6-SM ▶ UDLD 	▶ One license per stack member
AT-FL-x550-AM20-1YR	AMF Master license	▶ AMF Master 20 nodes for 1 year	▶ One license per stack
AT-FL-x550-AM20-5YR	AMF Master license	▶ AMF Master 20 nodes for 5 years	▶ One license per stack
AT-FL-x550-OF13-1YR	OpenFlow license	▶ OpenFlow v1.3 for 1 year	▶ Not supported
AT-FL-x550-OF13-5YR	OpenFlow license	▶ OpenFlow v1.3 for 5 years	▶ Not supported
AT-FL-x550-8032	ITU-T G.8032 license	<ul style="list-style-type: none"> ▶ G.8032 ring protection ▶ Ethernet CFM 	▶ One license per stack member
AT-FL-x550-CPOE	Continuous PoE license	▶ Continuous PoE power for XSPQm model**	▶ One license per stack member

Switches

AT-x550-18XTQ-xx

16-port 1G/10G BaseT stackable switch with 2 QSFP ports

AT-x550-18XSQ-xx

16-port 1G/10G SFP+ stackable switch with 2 QSFP ports

AT-x550-18XSPQm-xx

8-port 1G/2.5G/5G/10G BaseT PoE+ and 8-port 1G/10G SFP+ stackable switch with 2 QSFP ports

Note: switches ship with 19-inch rack mount brackets

AT-RKMT-J15

Rack mount kit to install two XTQ and/or XSQ devices side by side in a 19-inch equipment rack

Where xx = 10 for US power cord
20 for no power cord
30 for UK power cord
40 for Australian power cord
50 for European power cord

40GbE QSPF Modules

AT-QSFPLR4

40GLR4 1310 nm medium-haul, 10 km with SMF

AT-QSFPSR4

40GSR4 850 nm short-haul up to 150 m with MMF

AT-QSFP1CU

QSFP+ copper cable 1m

AT-QSFP3CU

QSFP+ copper cable 3m

Breakout Cables For 4 x 10G connections

AT-QSFP-4SFP10G-3CU

QSFP to 4 x SFP+ breakout direct attach cable (3 m)

AT-QSFP-4SFP10G-5CU

QSFP to 4 x SFP+ breakout direct attach cable (5 m)

10GbE SFP+ Modules

AT-SP10SR

10GSR 850 nm short-haul, 300 m with MMF

AT-SP10SR/I

10GSR 850 nm short-haul, 300 m with MMF industrial temperature

AT-SP10LRM

10GLRM 1310 nm short-haul, 220 m with MMF

AT-SP10LR

10GLR 1310 nm medium-haul, 10 km with SMF

AT-SP10LR/I

10GLR 1310 nm medium-haul, 10 km with SMF industrial temperature

AT-SP10LR20/I

10GER 1310nm long-haul, 20 km with SMF industrial temperature

AT-SP10ER40/I

10GER 1310nm long-haul, 40 km with SMF industrial temperature

AT-SP10ZR80/I

10GER 1550nm long-haul, 80 km with SMF industrial temperature

AT-SP10T

10GBase-T 20 m copper ^{1,2}

AT-SP10TW1

1 meter SFP+ direct attach cable

AT-SP10TW3

3 meter SFP+ direct attach cable

AT-SP10TW7

7 meter SFP+ direct attach cable

1000Mbps SFP Modules

AT-SPTXa

1000T 100 m copper

AT-SPSX

1000SX GbE multi-mode 850 nm fiber up to 550 m

AT-SPEX

1000X GbE multi-mode 1310 nm fiber up to 2 km

AT-SPLX10

1000LX GbE single-mode 1310 nm fiber up to 10 km

AT-SPLX10/I

1000LX GbE single-mode 1310 nm fiber up to 10 km industrial temperature

AT-SPBD10-13

1000LX GbE Bi-Di (1310 nm Tx, 1490 nm Rx) fiber up to 10 km

AT-SPBD10-14

1000LX GbE Bi-Di (1490 nm Tx, 1310 nm Rx) fiber up to 10 km

AT-SPLX40

1000LX GbE single-mode 1310 nm fiber up to 40 km

AT-SPZX80

1000ZX GbE single-mode 1550 nm fiber up to 80 km

Note that any Allied Telesis 40G or 10G module or direct attach cable can also be used for stacking. Stacking is also supported using the 10G RJ45 copper ports.

¹ Using Cat 6a/7 cabling

² Up to 100 m running at 1G