

FULL HEIGHT TURNSTILE

INSTALLATION AND MAINTENANCE HANDBOOK

WARRANTY CERTIFICATE

www.ozak-t.com

KK-1302-0002 R(9)
Y.T.13.06.2022

1.	GENERAL INFORMATION	4
1.1.	Preface	
1.2.	General Information on Turnstiles	
1.3.	Full-Height Turnstile Models	
2.	SAFETY AND OPERATION.....	5
2.1.	Safety Warnings And Symbols	
2.2.	Fuse Replacement	
2.3.	Safety Related Instructions	
2.4.	Operating Conditions	
3.	HANDLING AND INSTALLATION	6
3.1.	Handling	
3.2.	Installation	
3.3.	Mounting of Arms	
4.	TURNSTILE SYSTEM SPECIFICATIONS.....	7
4.1.	Full Height Turnstile Table of Specifications	
4.2.	Full Height Turnstile System Specifications (Standard)	
4.3.	Full Height Motorized Turnstile System Specifications	
4.4.	Indicators	
4.5.	Accessories	
5.	SETUP AND OPERATION.....	9
5.1.	Power and Ground Connections	
5.2.	Control Board Connections	
5.3.	Wiring Diagrams	
5.3.1.	Control Board Terminals	
5.3.2.	Internal Wiring Diagram	
5.4.	Control Board Settings	
5.4.1.	Inhibit (Enable/Disable) Terminal	
5.4.2.	Dip Switch Settings	
5.4.3.	TSC Manager Application	
5.4.4.	Magnetic Encoder Arm Stop Settings	
5.5.	Hydraulic Damper Adjustment (Manual Models)	
6.	POST INSTALLATION CHECK LIST.....	22
7.	SERVICE AND MAINTENANCE.....	22
7.1.	Maintenance Instructions	
7.1.1.	Recommended User Maintenance	
7.1.2.	Periodic Maintenance by Technical Service Personnel	
7.2.	Trouble Shooting And Repair Guide	
7.3.	Mechanism Assembly Exploded Diagrams	
8.	LIST OF COMMON REPLACEMENT PARTS.....	26
9.	CE DECLARATION OF CONFORMITY AND WARRANTY.....	27
9.1.	CE Declaration of Conformity	
9.2.	Warranty Certificate	
9.3.	Warranty Terms and Conditions	
9.4.	Cases Excluded from Warranty Coverage	

1. GENERAL INFORMATION

MANUFACTURER: Özak Geçiş Teknolojileri Sanayi Ticaret A.Ş.



Address : Çuhane Caddesi No:130 41080 Köseköy-KARTEPE / KOCAELİ
Tel & Fax : 90.262.373 48 48 – 373 66 09 Pbx.
E-mail : ozak@ozak-t.com
Web : www.ozak-t.com

1.1 Preface

Thank you for choosing the products of Ozak and your confidence in our company.

Your system has been designed and manufactured to meet the most demanding requirements of professional access control applications. All components of your system have been selected with utmost care and thoroughly tested to ensure optimal performance and reliability.

To safely operate your product with maximum performance and service life please follow the instructions written in this manual carefully, and keep it for future reference. In case of any operational questions or unexpected issues please refer to the explanations contained in this document.

To obtain technical support or replacement parts please contact Özak Technical Service Department by E-mail or telephone.

Özak Technical Service Department: Telephone: +90 262 373 48 48 ext: 1301-1304, E-mail: support@ozak-t.com

Özak reserves the right to change the contents of this document without prior notice!

1.2 General Information on Turnstiles

Turnstiles are devices that enable passage control and prevent uncontrolled or unauthorized passages in stadiums, sports halls, leisure facilities, business centers, public transportation areas, museums, banks, industrial facilities and all premises where access control in entry and exit is required.

As passage controlling units, turnstiles have the ability to work with various types of access control system such as barcode, magnetic card, proximity card readers, tokens, buttons etc. Ozak turnstiles are designed for bi-directional operation while featuring simple mode selection by a dip switch for restricted, one way controlled or free passage.

The turnstiles are made of stainless steel or electrostatic powder coated DKP sheet metal. In double-sided models, two separate passage systems are integrated into a single structure. As the turnstiles are firmly anchored on a wide surface area, the overall structure is well balanced and robust. Due to their structural characteristics, turnstiles are suitable for outdoor installations where they can be exposed to rain, wind, sunlight and similar conditions. All internal mechanical components are galvanized for protection against corrosion.

Our turnstiles are certified with “TSEK product quality” (A Turkish certification of quality) and CE Declaration of Conformity.

1.3 Full Height Turnstile Models

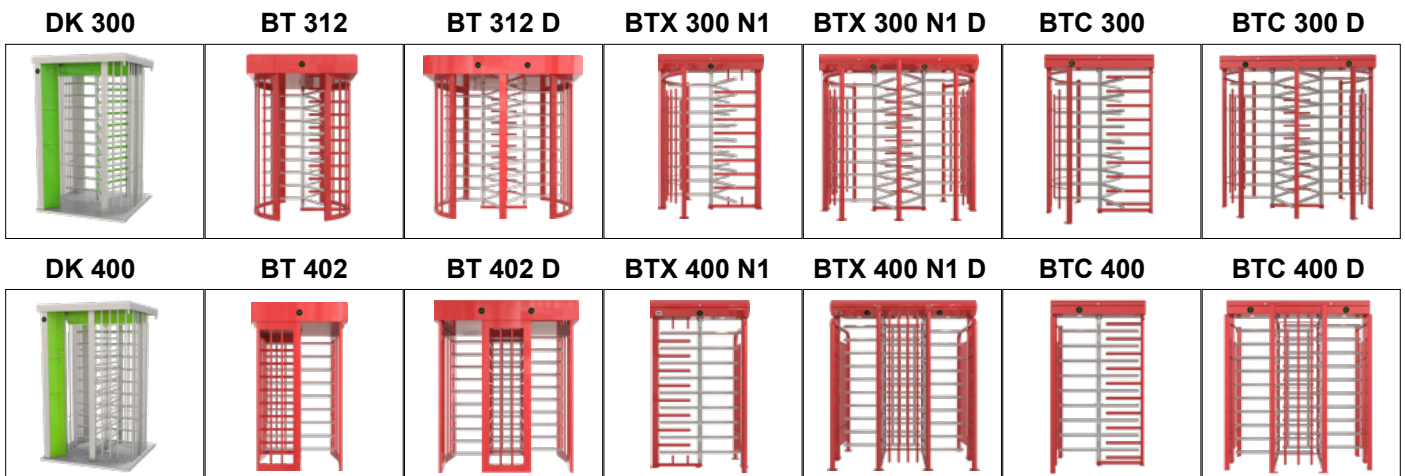

2. SAFETY AND OPERATION

2.1 Safety Warnings and Symbols

For Safety and proper operation of the turnstile all installation and repair work must be performed by qualified technical personnel only!

HIGH VOLTAGE WARNING LABEL

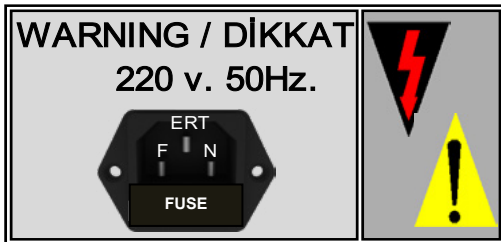

WARNING!

Never remove the protective cover of the power supply unit for any reason!
Observe the warning signs, power and fuse values when performing any work on the turnstile.
Warning labels and power supplies may vary depending on the turnstile model and type.

GROUNDING SYMBOL



WARNING! To avoid shock hazard AC power connections must be properly grounded!

POWER CONNECTOR FRONT VIEW

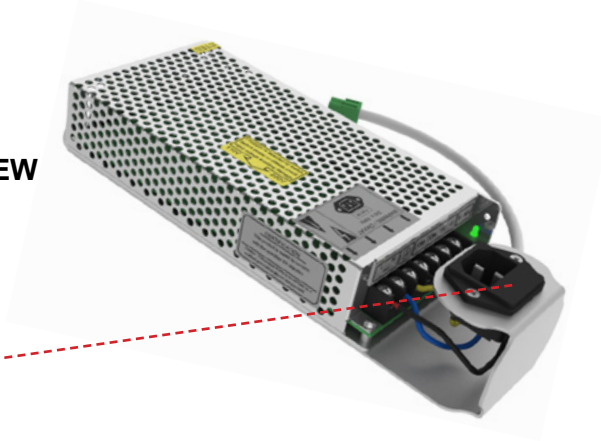
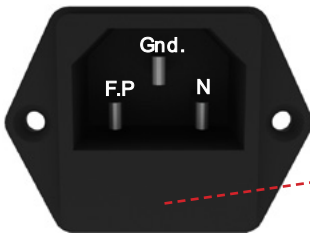

2.2. FUSE REPLACEMENT

CAUTION! Use only the same type and rating of fuse as selected by the manufacturer!

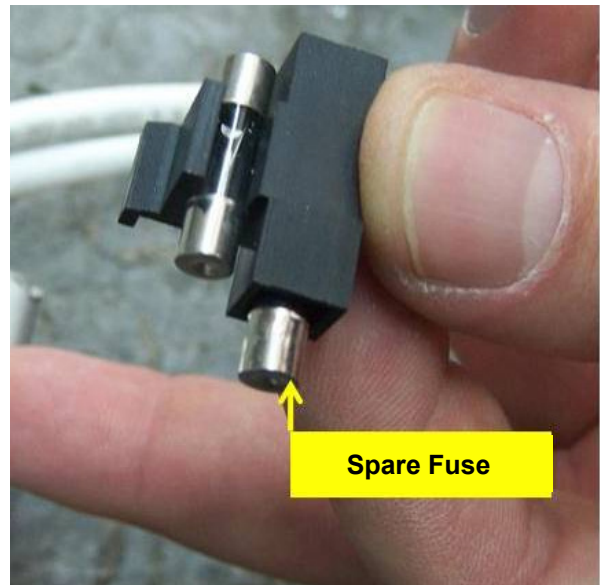
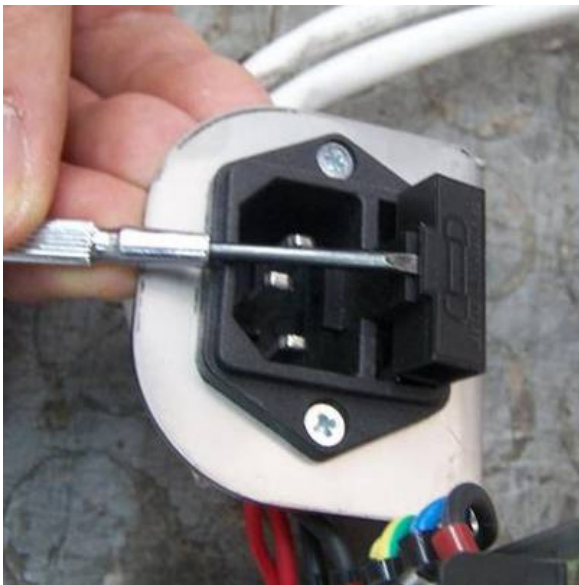

The fuse and a spare are located inside AC power socket

2.3 Safety Related Instructions

1. Users must not dismantle the turnstiles. Maintenance can only be performed by competent and authorized personnel. Maintenance work attempted by non-qualified individuals may create danger to users and the turnstile.
2. Turnstile must not be installed at places where there is a risk of explosion caused by electrical arcs or a probable gas leakage.
3. Turnstile must be kept away from flammable environments.
4. Turnstile should not be installed at places where there is vibration.
5. Turnstile must not be kept in excessively moist environments.
6. Turnstile must not be exposed to heat.
7. Turnstiles must not be subjected to abusive treatment such as impact or excessive shaking.
8. Turnstile must be kept away from high level magnetic fields.
9. Operating voltage/ power range must be observed in all installations. .
10. The power must be stable, properly grounded, insulated.
11. Turnstiles can only be operated under the environmental conditions and temperatures specified by the manufacturer.
12. Children must not be allowed to play with the turnstiles.
13. All connections must be confirmed to be correct before supplying power to the turnstile.
14. Only materials and equipment recommended by the manufacturer must be used for the turnstile when making connections into the input and output terminals.
15. All parts and accessories used in the turnstiles must be approved by the manufacturer.
16. In case of any electrical arching or faults caused by such condition, power must be disconnected and authorized servicer or manufacturer must be contacted as soon as possible.
17. The power must be cut off before cleaning or maintenance.
18. Only clean, soft and moist fabrics (no abrasive materials or chemicals) should be used for cleaning the turnstile.
19. Damaged turnstiles must not be operated, and the authorized dealer or the Manufacturers technical support center should be contacted soon as possible for repair.

2.4 Operating Conditions

1. More than one person must not attempt to pass at the same time.
2. Turnstile must not be forced, kicked, abused or tempered with to gain passage without authorization.
3. Turnstiles must not be washed for cleaning purposes (applying water with a hose or pouring water from a bucket etc.). Wiping off with non-abrasive materials such as a soft and clean damp cloth is sufficient in most cases.
4. Chemicals and abrasives must not be used in any case for cleaning. The manufacturer is not responsible for damages resulting from use of such materials.

3. HANDLING AND INSTALLATION

3.1 Handling

1. Please pay special attention to carry the turnstiles as originally packed by the manufacturer.
2. Follow the handling and carrying instructions written on the package.
3. Do not place a heavy load on the turnstile package.
4. Do not place the packed turnstile on a wet ground.
5. Do not leave the packed turnstile under rain.
6. During handling, use an appropriate lift/crane with sufficient lifting capacity.
7. Before starting installation ensure that there is no shipping damage or missing parts and hardware inside the package.

3.2 Installation

1. The installation place should be selected according to user's requirements. This selection should not prevent the smooth operation of the turnstiles.
2. Ensure that the installation surface is flat, even and of proper strength. Flatten any uneven/ rough areas if necessary.
3. Mark the holes and drill with a 12 mm drill bit. Clean the debris inside the holes by pressurized air.
4. Fill the holes with chemical plaster and fix anchoring bolts (10 mm) in place by rotating. Chemical plaster dries in about 25 minutes.
5. Place turnstile on anchoring bolts and tighten the nuts to secure in place.
6. Connect power and control cables. Power and control cables can be routed up through the structural pipes of the turnstile using guide wires. Cable length extending from ground should be at least 4 meters.

Note: A model specific mounting plan is supplied with each turnstile.

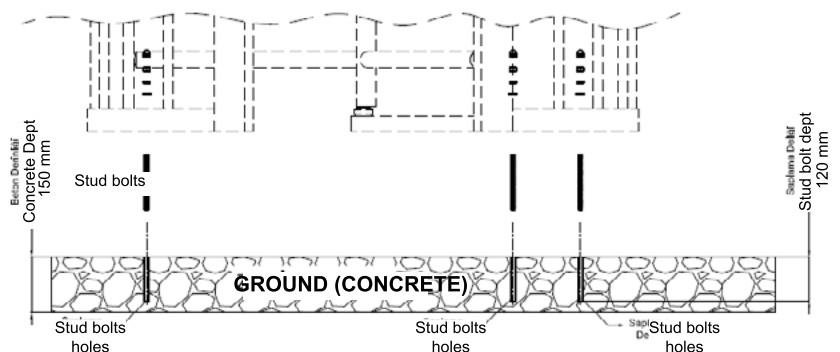

**MOUNTING DETAILS
GROUND PLAN**

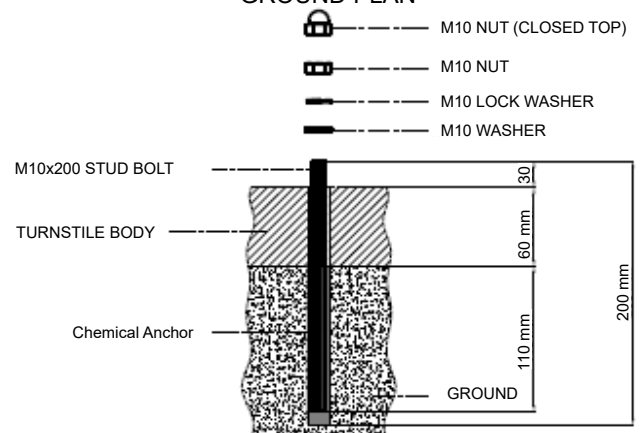

3.3 Mounting of Arms

Caution! Arms can loosen and fall if not mounted correctly.

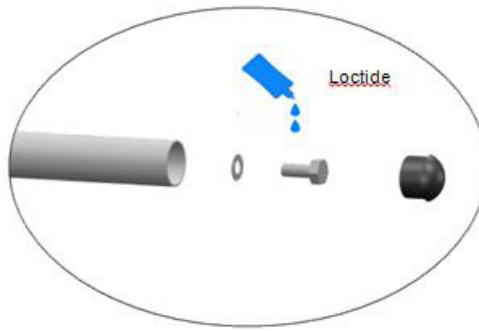
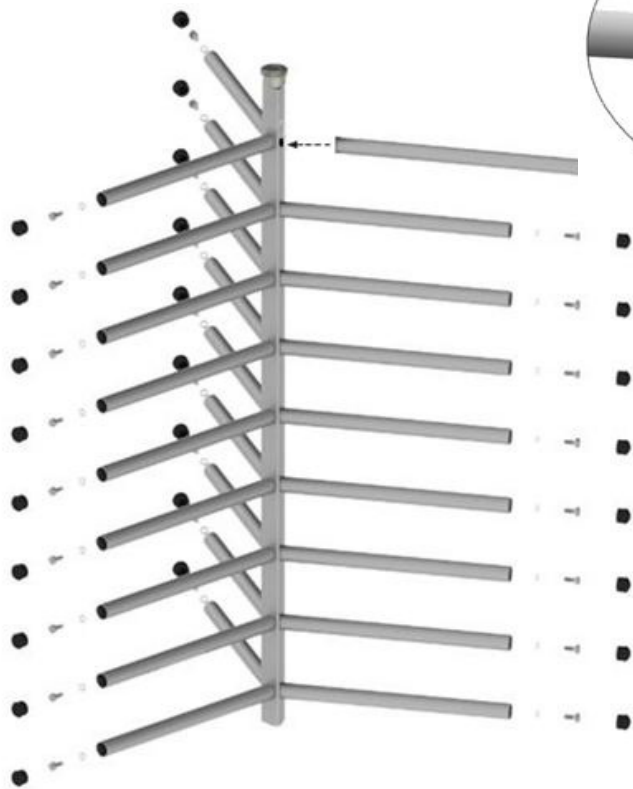

19 mm socket wrench with long handle

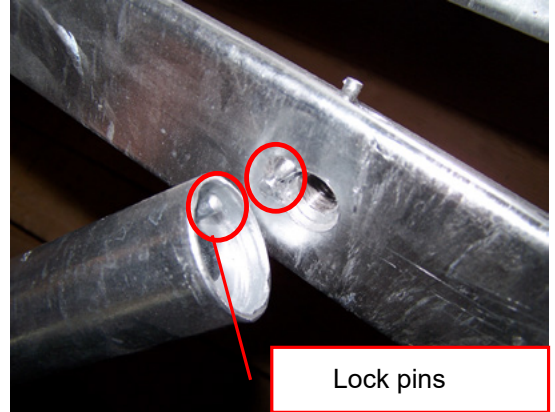

Lock pins

Attach arms on the rotor and turn counter clockwise until lock pins are engaged to prevent removal of the arms by turning. Fully tighten arm bolts (apply loctide) and install arm caps by tapping with a rubber hammer.

Lift the mechanism channel at one end to correctly adjust rotor position and re-seat it on the rotor coupler. Refer to detailed assembly instructions supplied with each turnstile model.

Mounting of Arms

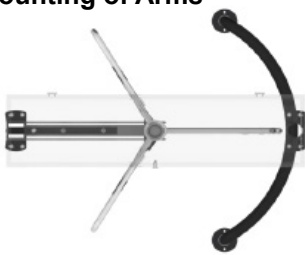

Correctly Installed Rotor

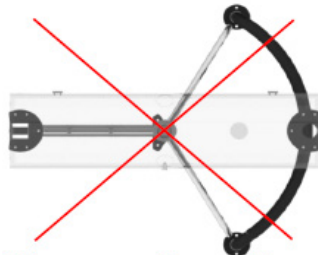

Incorrectly Installed Rotor

4. TURNSTILE SYSTEM SPECIFICATIONS

4.1 Full Height Turnstile Table of Specifications

MODEL	Mechanism		Operation			Materials				
	Manual	Motor Driven	Movement	Lock Control	Stop	Structural Materials	Rotor & Arm	Arm Configuration		
BT 312 S / D	✓	O	Push to Rotate (Optional Motorized)	Solenoid	Hydraulic Damper	-Hot Dip Galvanized Steel	-Hot Dip Galvanized Steel	3 Arms (120°)		
BT 402 S / D								4 Arms (90°)		
BTE 312 S / D								3 Arms (120°)		
BTE 402 S / D								4 Arms (90°)		
BTX 100								1 Arm (90°+90°)		
BTX 300 S / D								3 Arms (120°)		
BTX 400 S / D								4 Arms (90°)		
BTA 300 *								3 Arms (120°)		
ECOLINE 300 S / D								3 Arms (120°)		
ECOLINE 400 S / D								4 Arms (90°)		
BT 302 GL *								-Glass (Side Walls)	-Acrylic (arm, for BTA300)	3 Arms (120°)
BT 400 GL *								-Aluminium	4 Arms (90°)	
BT 402 GL *	-304 / 316 Grade Stainless Steel	4 Arms (90°)								

✓ : Standard
 O : Optional
 * : Opt. different materials

4.2 Full- Height Turnstile System Specifications (Standard)

1. System is designed for bi-directional operation. In standard models, when power is cut off, arms freewheel to allow free passage in both directions; optionally the system can be set up to lock (fail-lock) when power is cut off.
2. Mechanical parts of the turnstiles are made of stainless steel and galvanized metal. All locking mechanism components are made of stainless steel.
3. Once passage is permitted and arms rotate 30 degrees, arms will not return, and another passage is not allowed by the system until the completion of the movement.
4. After each complete passage the manual system returns to standby position smoothly and quietly by means of a hydraulic shock absorber. Motor driven versions complete rotation by a light push following authorization.
5. Signalization is provided with direction indicators placed on both sides of the upper body of the turnstile (While green arrow indicates active passage direction, red bar shows the inhibited passage direction). In addition to the visual signalization with green/ red indicators, an audio buzzer signal is provided during passage.
6. Solenoids used within the system are driven by PWM for reliability, optimal energy efficiency and less heat. They do not warm up to more than 10 degrees above the ambient temperature.
7. Electronic board controlling the system is “coated inside the hole’ type” and therefore not affected by vibration.
8. The micro-processor based electronic control system used in the turnstiles can be programmed for various functions and operating modes by a simple dip switch selection.
9. All inputs and outputs are isolated by opto-coupler and relay components for increased reliability.
10. Turnstile passage directions can be inhibited (closed), set up for one way traffic or normal bi-directional operation by enable/disable terminal located on the control board.
11. The power supply is supported by “switching-mode” technology for better voltage regulation and energy efficiency.
12. Turnstile only allows passages of authorized people. If a person does not pass within a pre-set time limit following authorization contact (selectable for 6, 12, 18 or infinite seconds), the system automatically locks and returns to standby.
13. After each complete passage, the system provides dry contact relay output for each direction. An optional counter can be used.
14. Electronic control unit of the turnstile is protected against water for outdoor installations.
15. Turnstiles can work in sync with door-type metal detectors; In security applications, even passage of a person with authorization can be blocked automatically upon receiving contact from a metal detector. The system can be returned to normal operation by the operator.
16. In cases of emergency the turnstile can be switched into “emergency mode” with a normally closed manual button or relay from fire alarm system. In emergency mode arms rotate freely in both directions allowing free passage.
17. Turnstile passage directions can be arranged in different combinations by a dip switch on the control board. (For example: one direction controlled other direction free; both directions controlled by separate readers, single reader for both directions.)
18. Turnstiles allow passage of only one person at a time for each authorization contact into the control board.
19. Card readers or similar access control systems can be integrated into the turnstiles separately or jointly for controlling both sides depending on the needs and specific requirements.
20. Once a passage is completed, an entrance or exit direction data (dry contact) is provided to the data collection terminal.

4.3 Full Height Motorized Turnstile System Specifications

1. Microprocessor controlled bi-directional system incorporates an efficient PWM driven DC motor.
2. Upon passage authorization received by the control board, system activates the motor following a light push on the rotor and completes the rotation of 90° or 120° depending on the model. The rotor stops and tries to continue its rotation once more if it meets an obstacle during its movement. If the obstacle is still present the rotor stops an alarm is activated.
4. Following a complete passage (90° or 120° rotation) turnstile locks and becomes ready for the next passage.
5. **Emergency mode:** Controlled by a **normally closed (NC)** button or fire alarm system contact. Turnstile will rotate free in both directions as long as the emg contact remains open. Upon re-establishment of emg contact, turnstile returns to normal operation mode.

4.4 Indicators

The system features status indicators on both sides and a buzzer for user guidance.



RED X: Passage way closed (see 5.2')

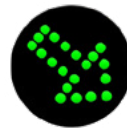

GREEN ARROW: Passage way open.



Buzzer is heard when a passage is authorized.

In alarm mode the indicators alternately blink in red and green and buzzer is heard.

4.5 Accessories



Remote Control (RF)



Remote Control (Wired)



Counter



Coin System



Reader Post



Mounting Bracket



Mounting Bracket



Reader Bracket With Pole

5. SETUP AND OPERATION

5.1. Power and Grounding Connections

TURNSTILE POWER WARNING LABEL

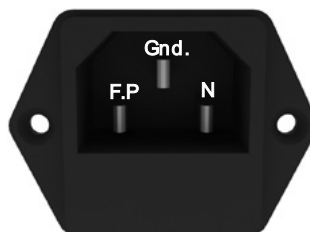

Warning! Power and grounding connections must be made by a qualified electrician in accordance with the relevant local regulations using appropriate materials!



Warning! Proper grounding must be ensured to prevent shock hazard!



Warning! Do not attempt to repair the power supply by removing the cover. Power supply must be replaced in case of failure with an original unit which can be obtained from Ozak.

5.2 Control Board Connections

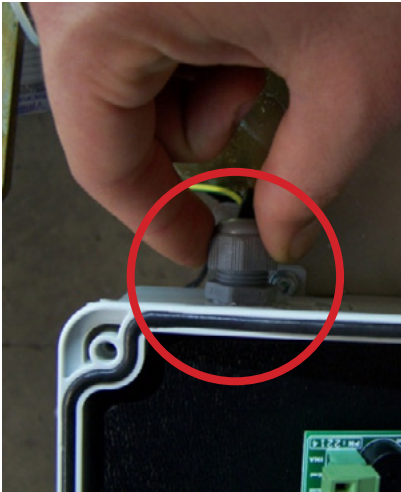

1. Loosen wire entry hole cover screw.

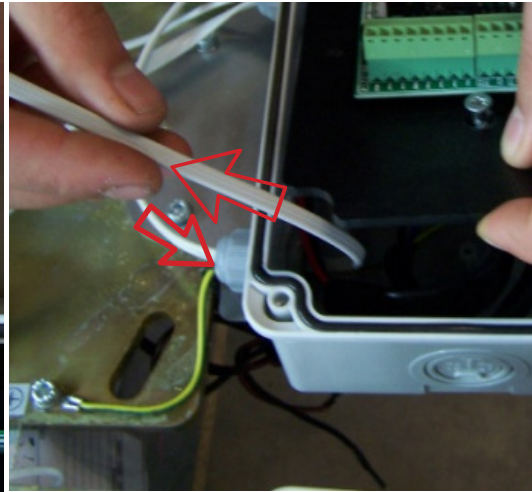

2. Insert Control cable.

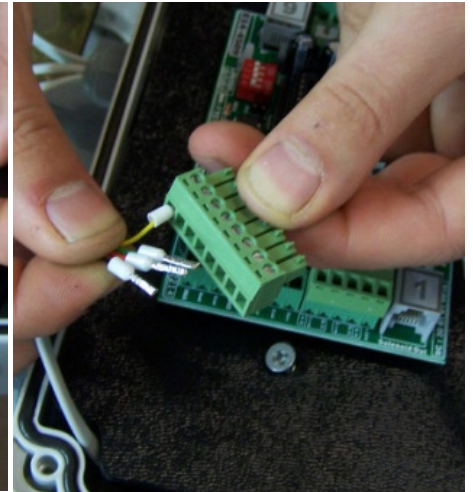

3. Connect cable leads into the screw type connector.

For TRN 1203

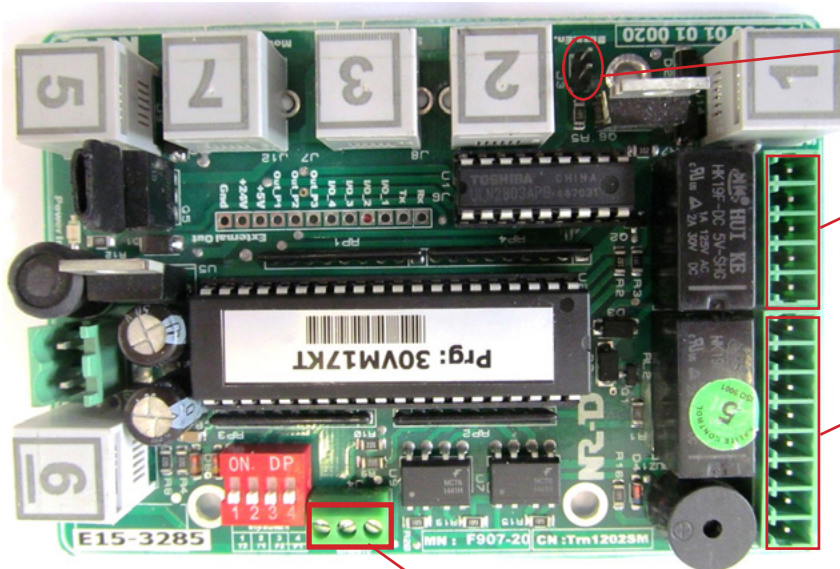

Buzzer Jumper: Mutes buzzer when removed

Passage Confirmation Relay
 A-B } NO (Normally Open) Dry Contact
 Com }
 B-A }
 Com }

Control Input Terminal
 IN A } NO (Normally Open) Dry Contact
 IN B }
 Reset }
 Gnd (Common) }

Emg (Emergency): NC (Normally Closed Contact) *

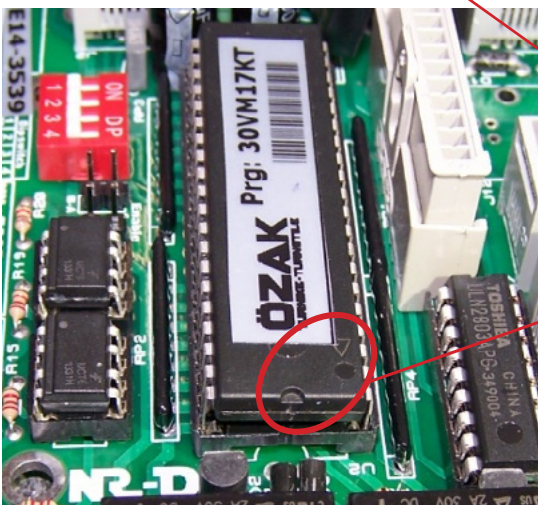

Enable/ Disable (Inhibit) terminal (A-B or B-A) Inhibits passage when connected to Gnd (common)

Caution! Pay attention to pin markers when inserting a new microprocessor into socket. Firmware number must be correct.

Caution! Match socket and cable tumber tags when replacing board and other parts!



Note: Control contact duration of 1 second or less is recommended for optimal flow rate.
 * Emg (Emergency) terminal is controlled by NO (Normally Open) contact in units produced before April 2016.

For TRN 1901 / TRN 2101

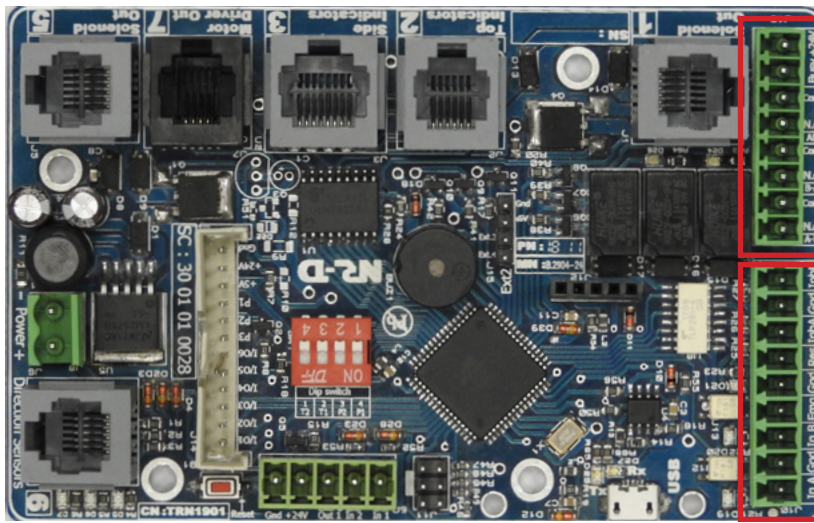

Passage Confirmation Relay
 A-B } NO (Normally Open) Dry Contact
 Com }
 B-A }
 Com }

Control Input Terminal
 IN A } NO (Normally Open) Dry Contact
 IN B }
 Reset }
 Gnd (Common) }

Emg (Emergency): NC (Normally Closed) Contact *

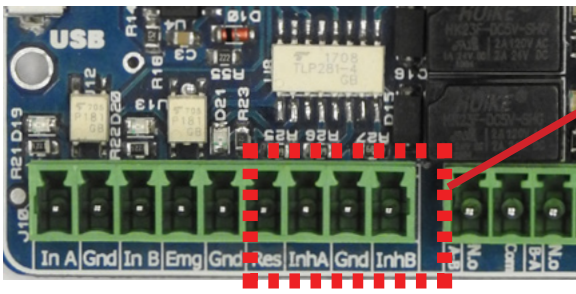
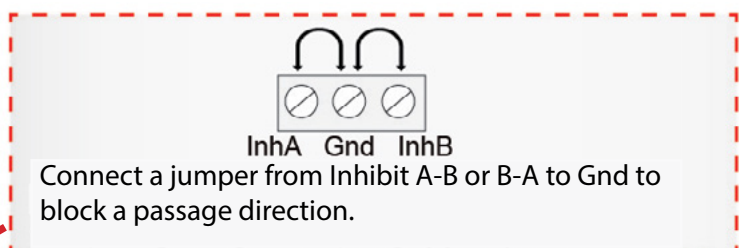

⚠ Match socket and cable numbers when replacing boards and other parts !



Note: Control contact duration of 1 second or less is recommended for optimal flow rate.
 * Emg (Emergency) terminal is controlled by NO (Normally Open) contact in units produced before April 2016.

5.3 Wiring Diagrams
 5.3.1 Control Board Terminals
 For TRN 1203

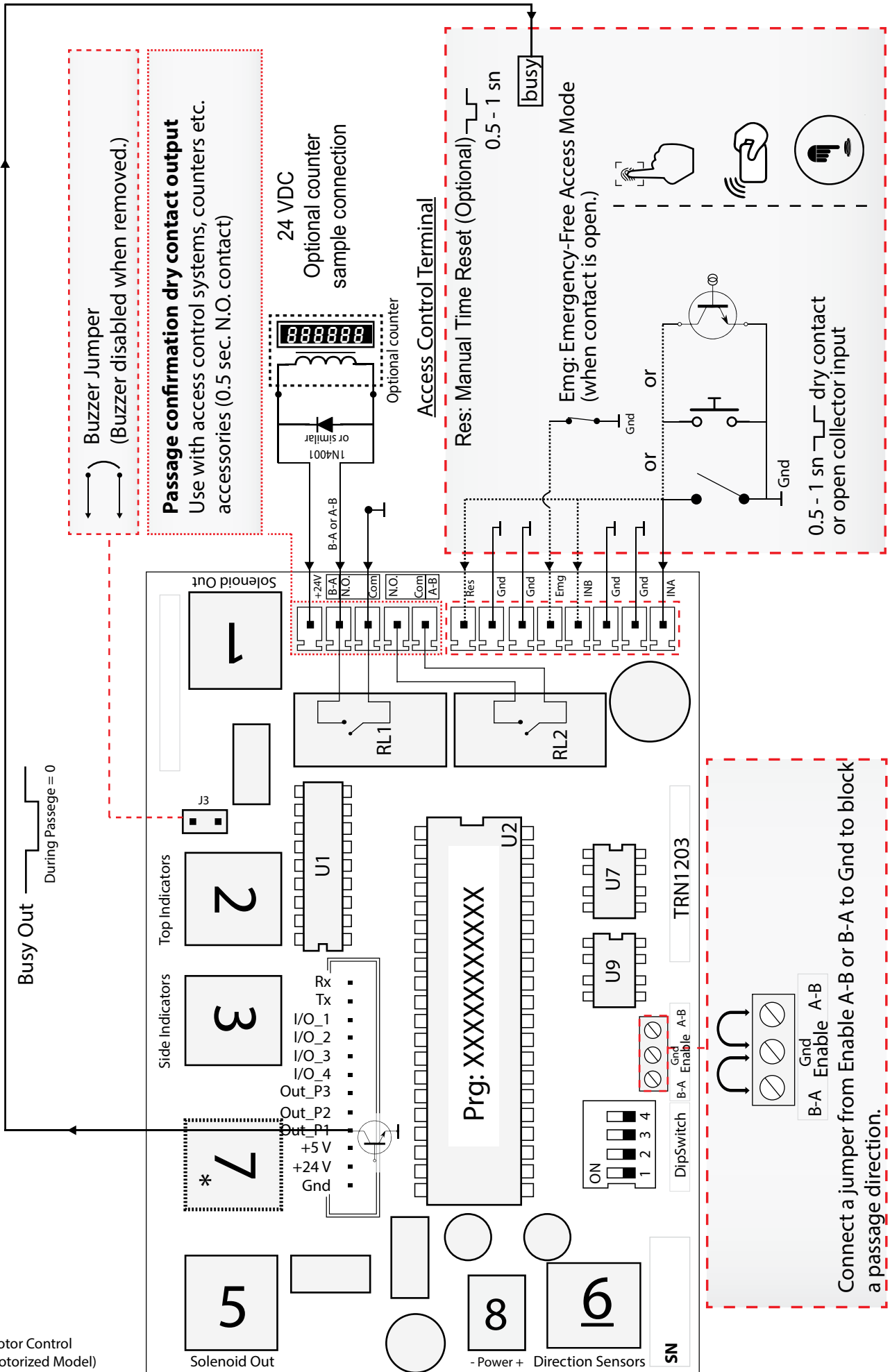

*Motor Control (Motorized Model)

Passage confirmation relay contact terminals;
Use with access control systems, counter etc.
(500mS N.O. contact)

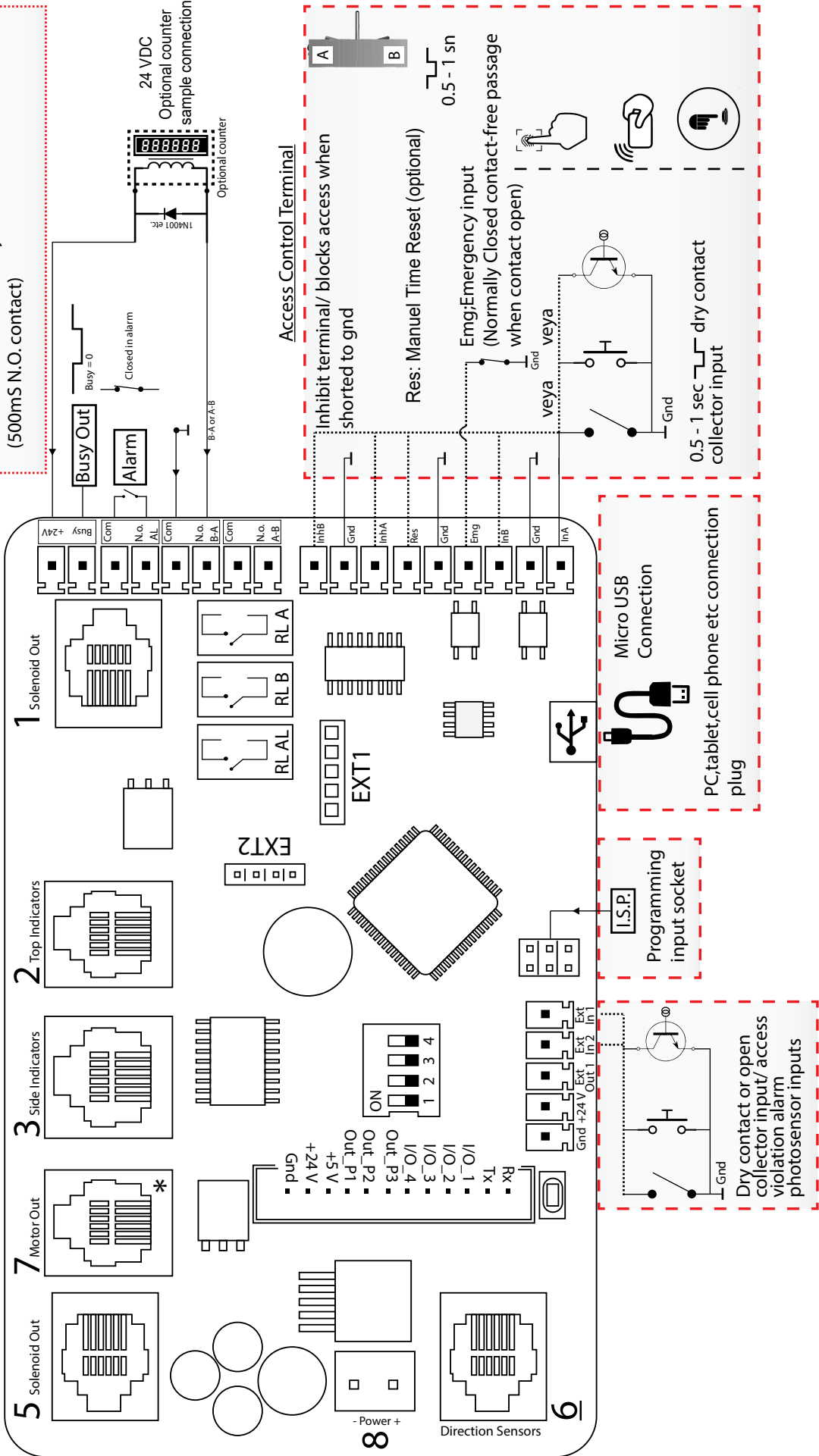

*Motor Control (Motorized Models)

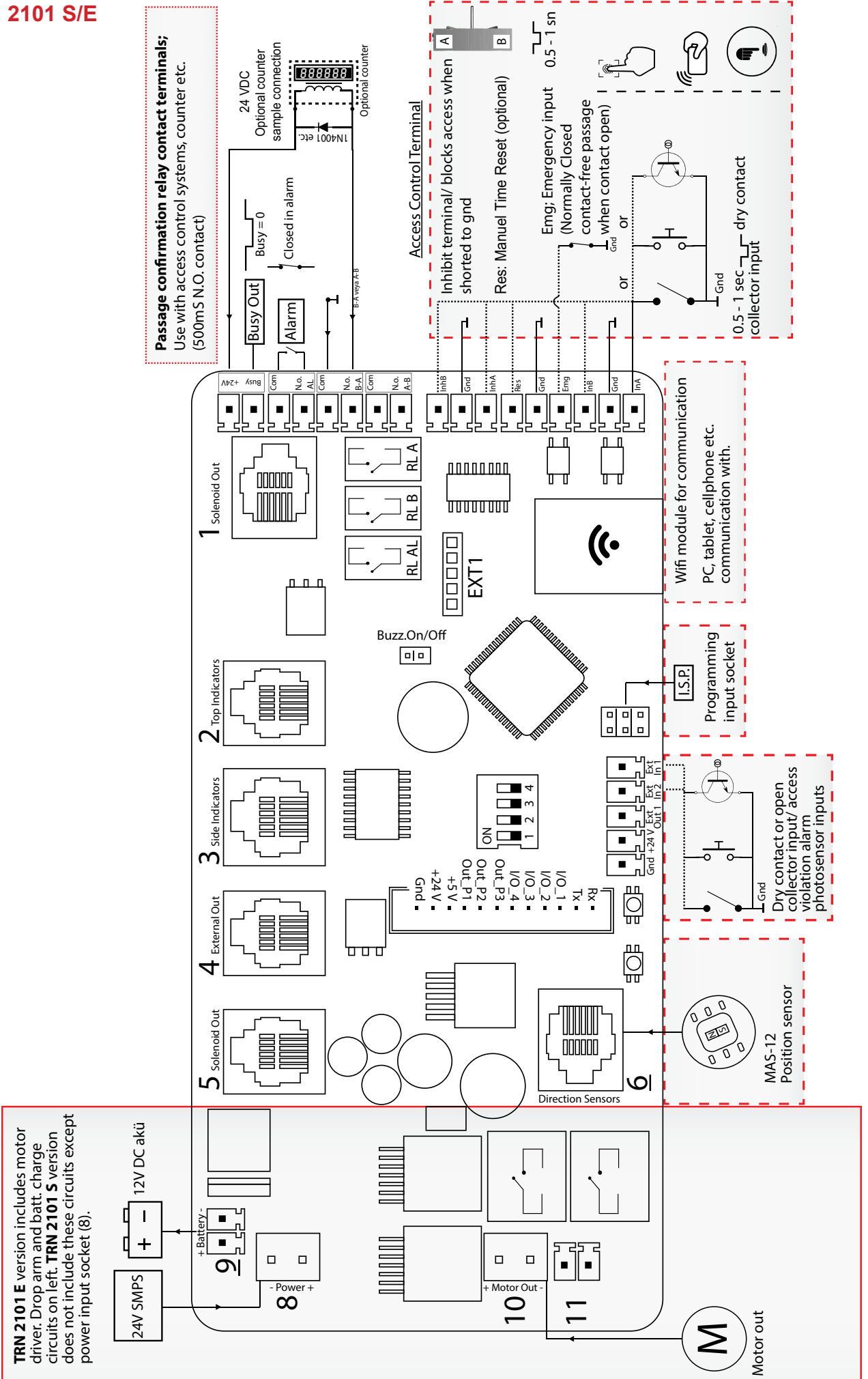

5.3.2 Internal Wiring Diagram
For TRN 1203

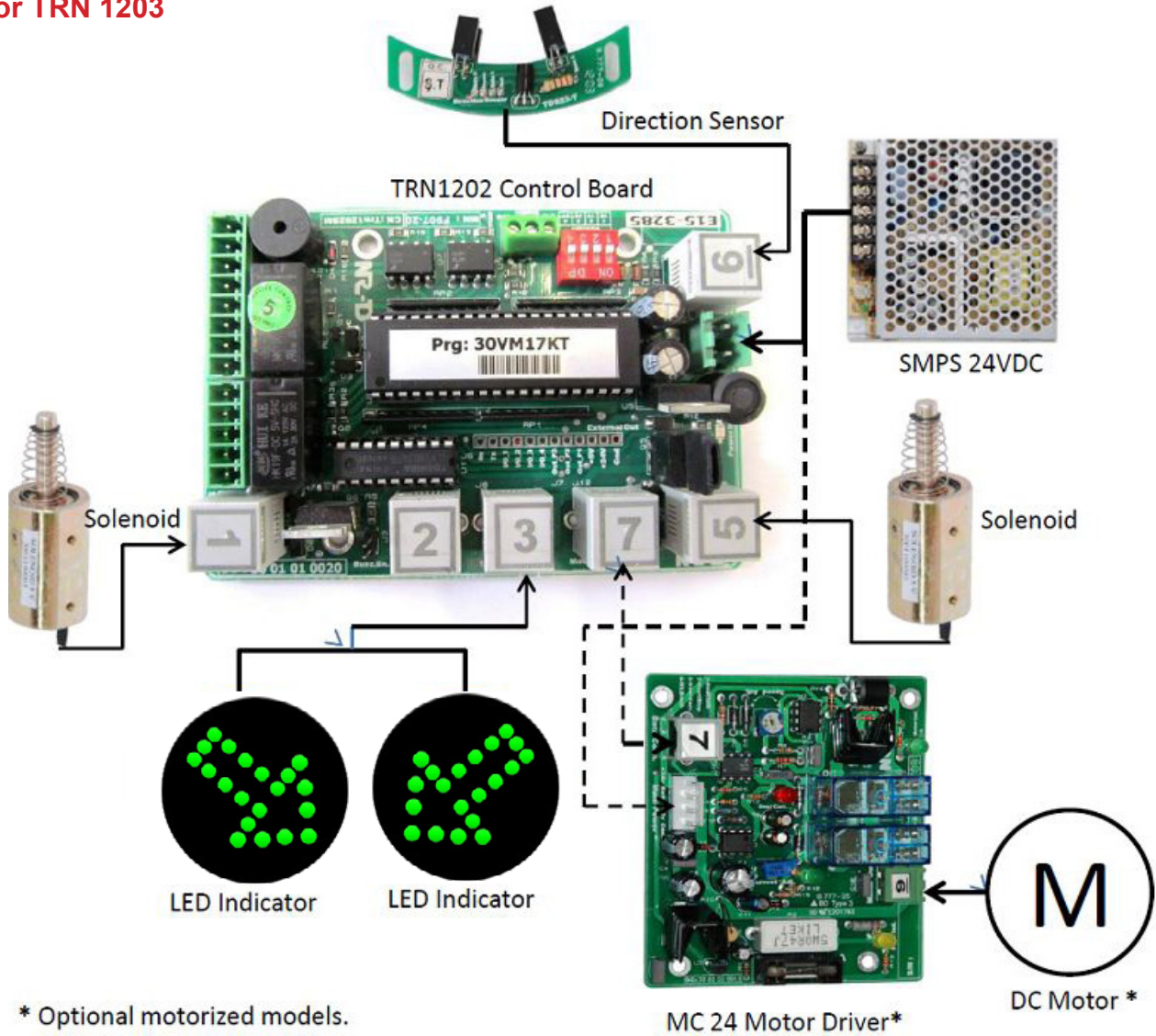

* Optional motorized models.

MC 24 Motor Driver*

DC Motor *

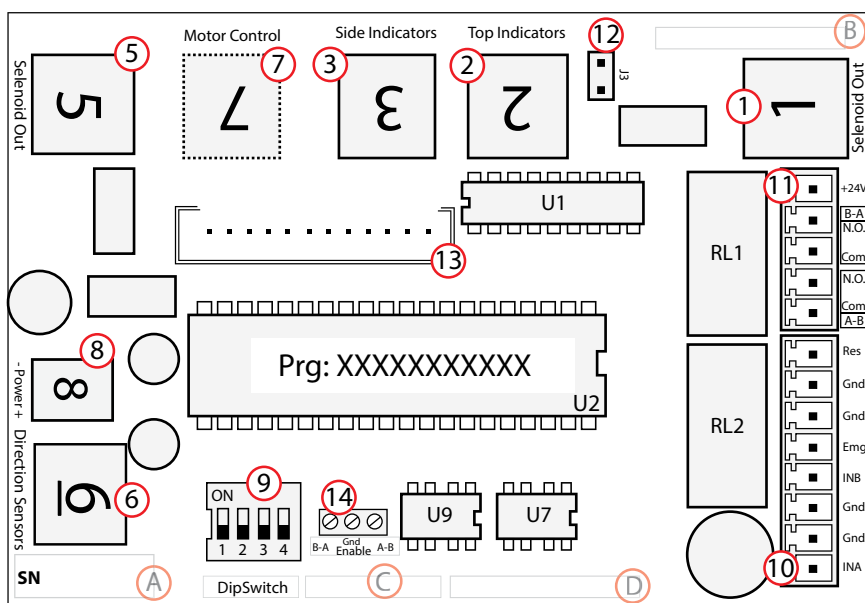

1. Solenoid A-B
 2. Top Passage Indicator and Buzzer
 3. Side indicators
 4. Optional Comm. Port
 5. Solenoid B-A
 6. Direction Photo Sensor
 7. Motor Control
 8. Power Input (24 VDC)
 9. Dip Switch
 10. Control Inputs
 11. Passage Confirmation Contact
 12. Buzzer Enable/Disable
 13. External Module Connector (Motor Driver, Drop Arm Control etc.)
 14. Enable Disable (inhibit)
-
- A. Board Serial Number
 B. Stock Code
 C. Production Number
 D. Board Model

5.3.2 Internal Wiring Diagram

For TRN 1901

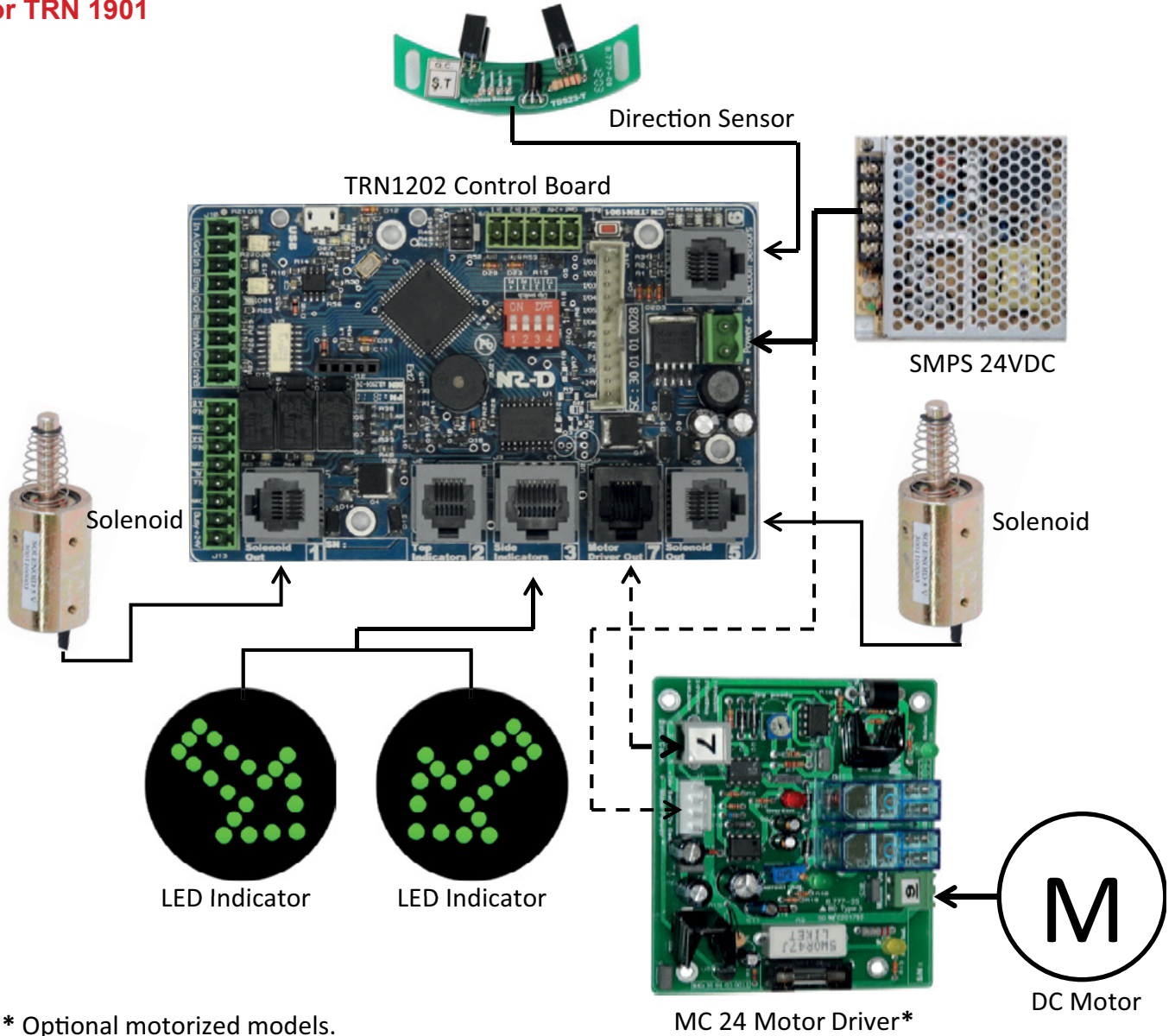

* Optional motorized models.

MC 24 Motor Driver*

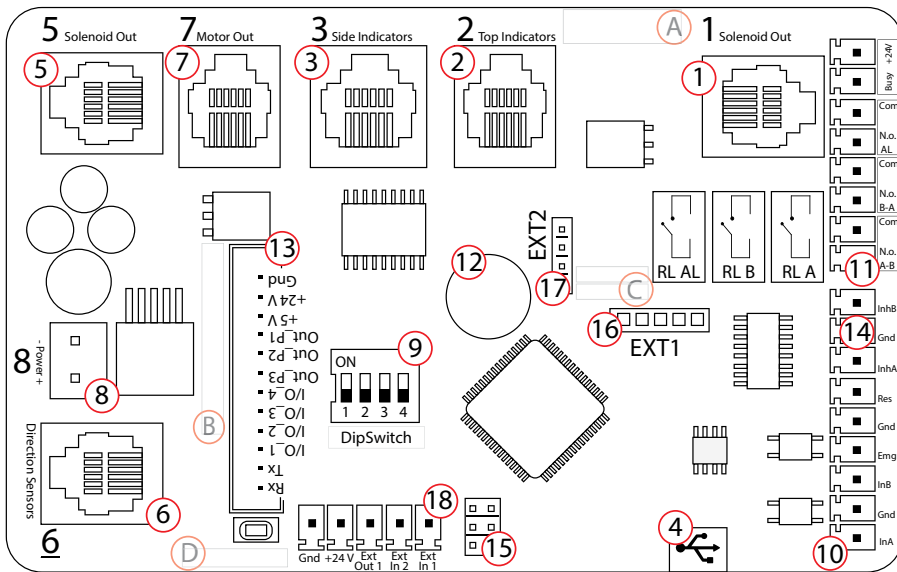

1. Solenoid A-B
2. Top Indicator
3. Side Indicator Outputs
4. USB Comm. Port
5. Solenoid B-A
6. Direction Photosensor Inputs
7. Motor Control (Motorized Models)
8. Power Input
9. Dip Switch
10. Control Inputs
11. Passage Feedback Relay Outputs
12. Buzzer
13. Auxiliary Modul Connections (Motor Drive, Drop Arm Control Board etc.)
14. Inhibit Terminal
15. ISP Connection
16. Extra Comms. Modul Connection
17. Extra Connector
18. Auxiliary Connector

-
- A. Board Serial Number
 - B. Stock Code
 - C. Production Number
 - D. Board Model

TRN 2101 S/E

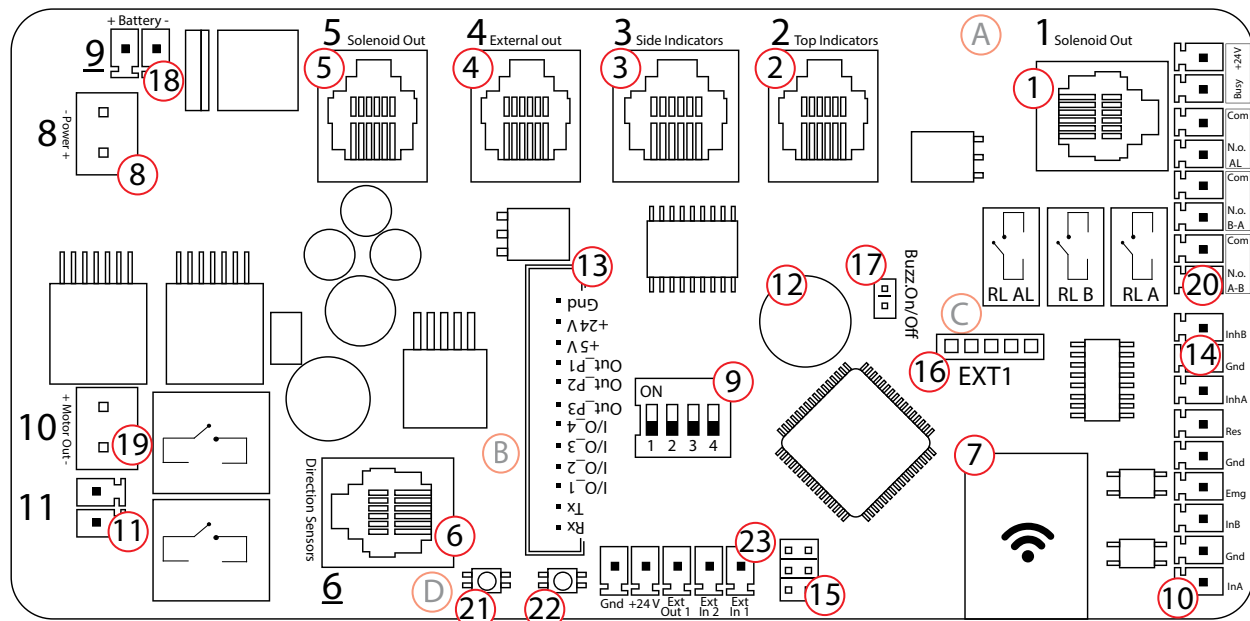
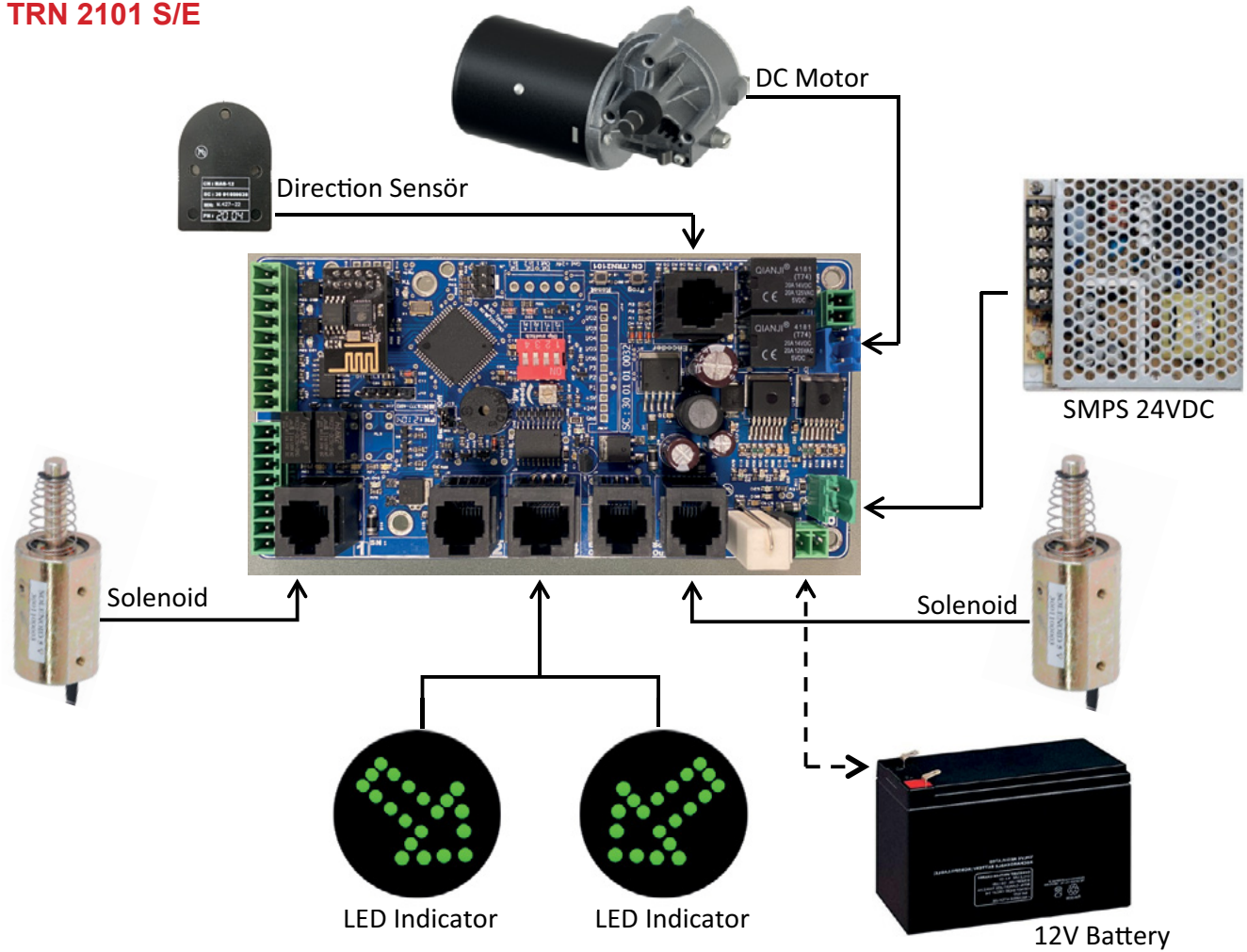

- | | | |
|----------------------------------|---|------------------------------------|
| 1. Solenoid A-B | 11. Drop Arm Socket | 19. Control Inputs |
| 2. Top Indicator | 12. Buzzer | 20. Passage Feedback Relay Outputs |
| 3. Side Indicator Outputs | 13. Auxiliary Modul Connections
(Motor Drive, Drop Arm Control Board etc.) | 21. Service Button |
| 4. External Out | 14. Inhibit Terminal | 22. Reset Button |
| 5. Solenoid B-A | 15. ISP Connection | 23. Auxiliary Connector |
| 6. Direction Photosensor Inputs | 16. Extra Comms. Modul Connection
(RS 485 / 232 / TCP IP) | |
| 7. Wifi Module For Communication | 17. Buzzer On/Off | A. Board Serial Number |
| 8. Power Inpit | 18. Dip Switch | B. Stock Code |
| 9. Battery Socket | | C. Production Number |
| 10. Motor Output Socket | | D. Board Model |

5.4 Control Board Settings

5.4.1 Inhibit (Enable/Disable) Terminal

To inhibit access through the turnstile in A or B direction, short A-B or B-A terminal to Gnd with a jumper. Turnstile will not allow passage in the inhibited direction and indicator for that direction will turn red to show inhibited access. This feature can be used with a metal detector to automatically block Access for Security purposes or setting the turnstile for one way passage.

For TRN 1203

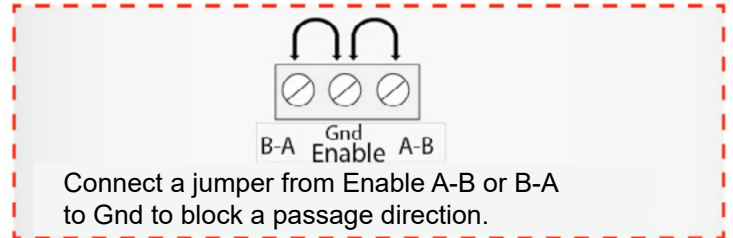
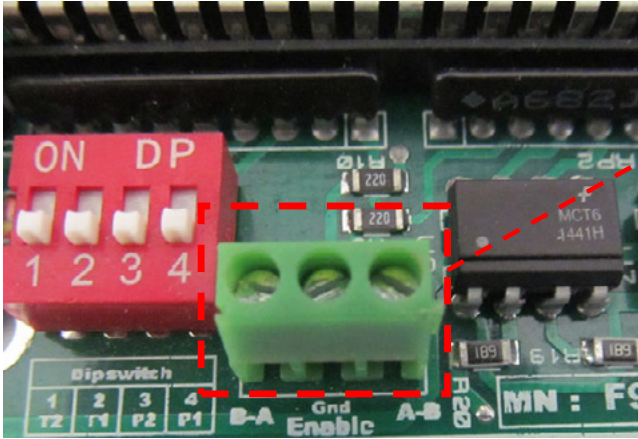

For TRN 1901 - For TRN 2101S/E

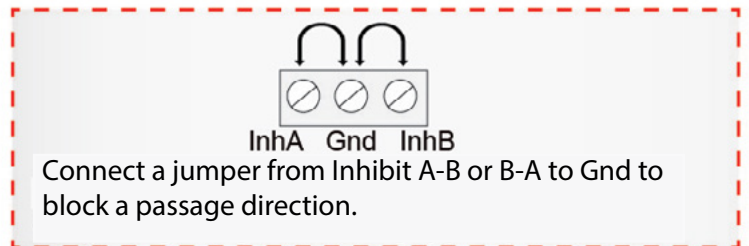
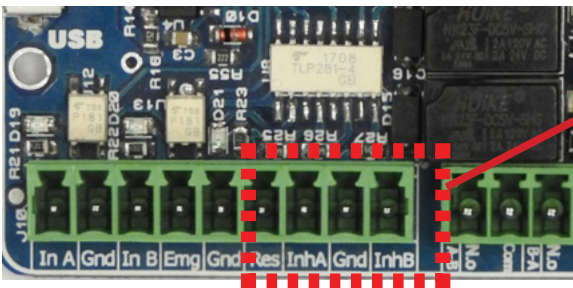

5.4.2 Dip Switch Settings

Time out and mode settings of the turnstile are selected by the dip switch located on the control board as explained below.

SWITCH NO	EXPLANATION
1	TIME SETUP 1
2	TIME SETUP 2
3	PROGRAM SETUP 1
4	PROGRAM SETUP 2

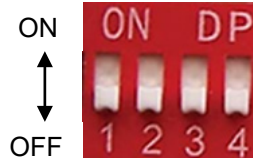

TIME SETUP		
DIPSWITCH		
1	2	TIME
OFF	OFF	6 sec.
ON	OFF	12 sec.
OFF	ON	18 sec.
ON	ON	INFINITY

FUNCTION (PROGRAM) SELECTION			
DIPSWITCH			
3	4	FUNCTION	DIAGRAM
OFF	OFF	Bi-directional operation	1
ON	OFF	B-A free, A-B controlled access	3
OFF	ON	Single input, activation in both directions	2
ON	ON	A-B free, B-A controlled access	4

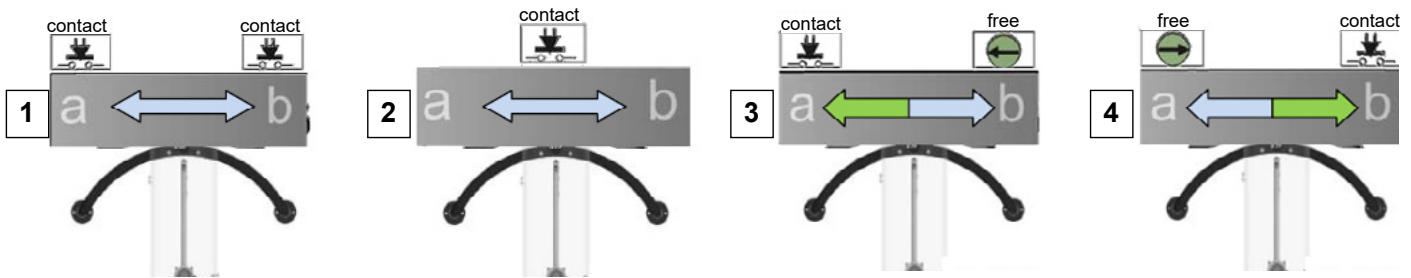

1. Bi-directional controlled passage: A separate card reader or button is used for each direction
2. Bi-directional passage by a single control device: A single reader or button connected into In A allows passage in both directions
3. B direction free, A direction controlled passage
4. A direction free, B direction controlled passage: Example: Controlled entry – free exit into a building.

5.4.3 TSC Manager Application



TSC Manager app allows quick access to turnstile settings with on/off switch options in the menu. TSC Manager application can be downloaded from google playstore which is available in all android phones. Scan the QR code on the right to download TSC Manager application.

Note: Additional settings for new version TRN1901 (Micro USB) and TRN2101 (Wi-Fi) control board equipped turnstiles can be made by downloading the TSC Manager Application from Google Play.

TSC Manager USB



TSC Manager WiFi



5.4.4 Magnetic Encoder Arm Stop Settings

TRN2101 CONTROL BOARD/ 3 and 4 Arm Turnstile Rotor Arms Centre Position Settings

System reset and service/ adjustment mode

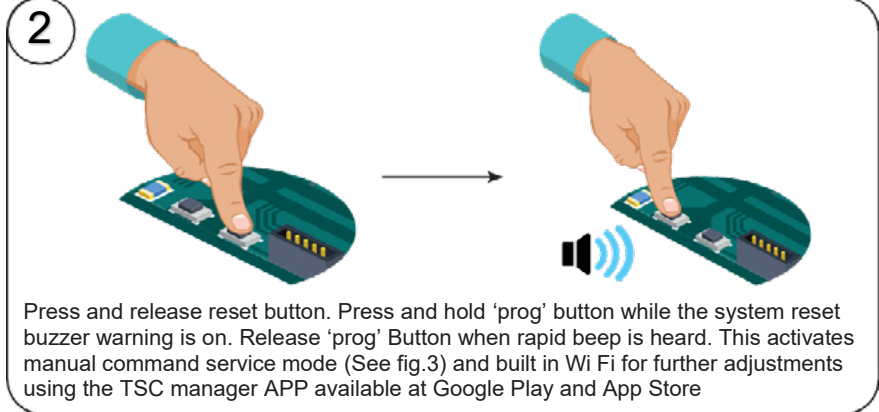
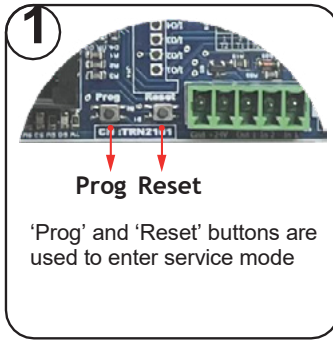

Single Button Setting Mode



Arm Position Setting

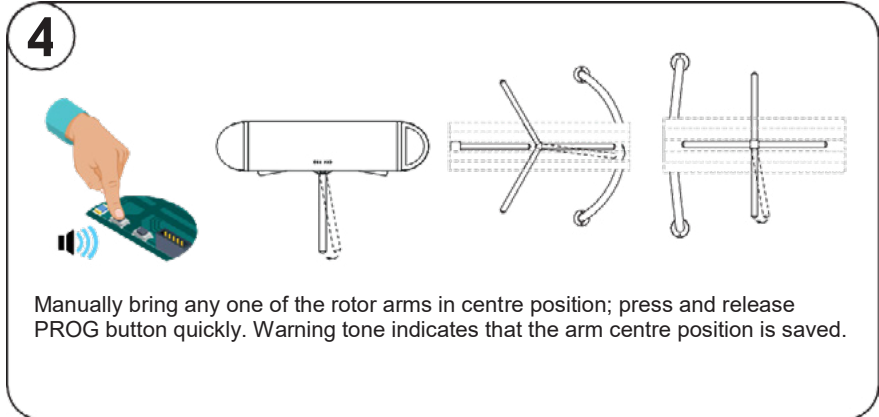

Setting Other Arm Positions

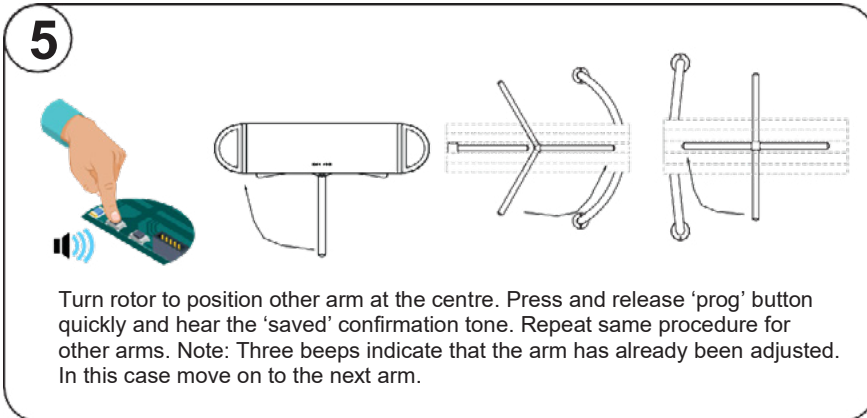

Saving Settings



Exiting Service Mode

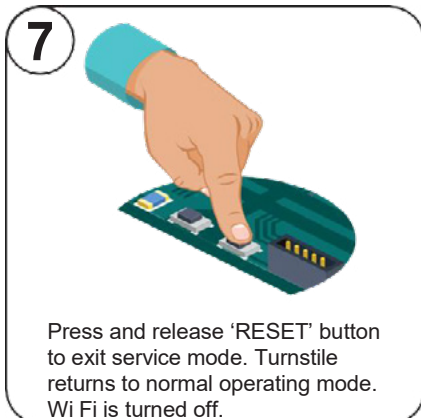

Note: Further adjustments can be performed using the TSC Manager Application which can be downloaded to a mobile device from Google Play or Apple Store. Connect your mobile device by built in Wi Fi to access service/ adjustment mode.

5.5 Hydraulic Damper Adjustment (Manual Models)

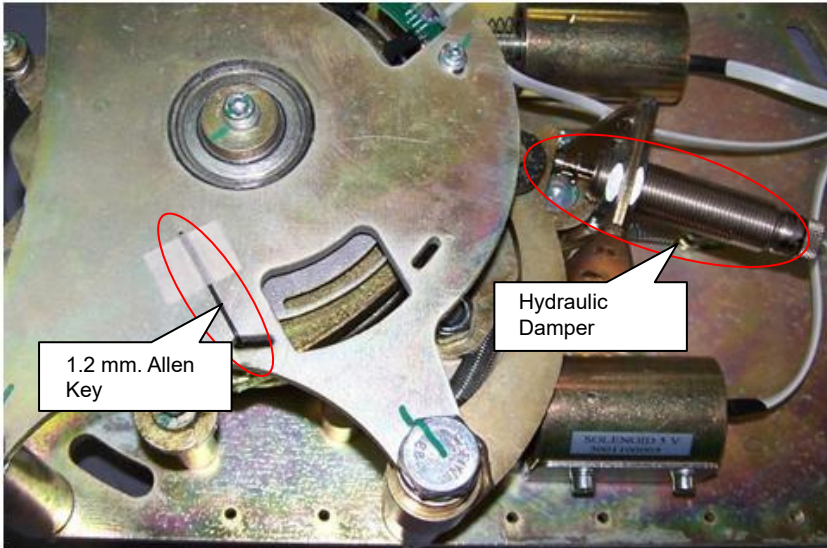

Damper Adjustment:

Due to large variations in ambient temperature or wear hydraulic damper adjustment may be required. Example; In very cold temperatures damping should be reduced if the rotor can not quickly return to rest position following rotation. In warm areas, if the rotor fails to stop smoothly at the rest position and bounces, then the damping should be increased.

Before adjusting the damper, loosen the dial stop screw with 1.2 mm. Allen key taped on the mechanism.

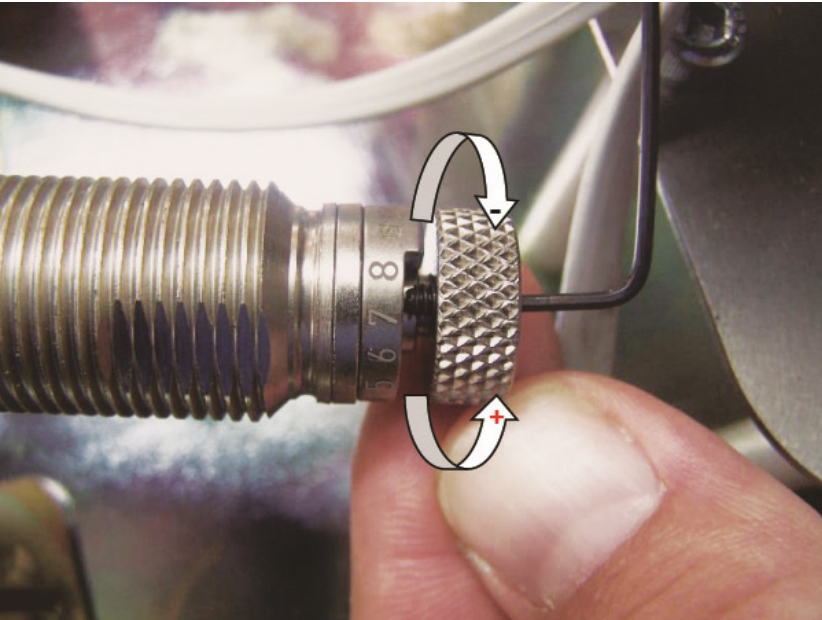

Note: Damping factor is increased when dial is turned clockwise.

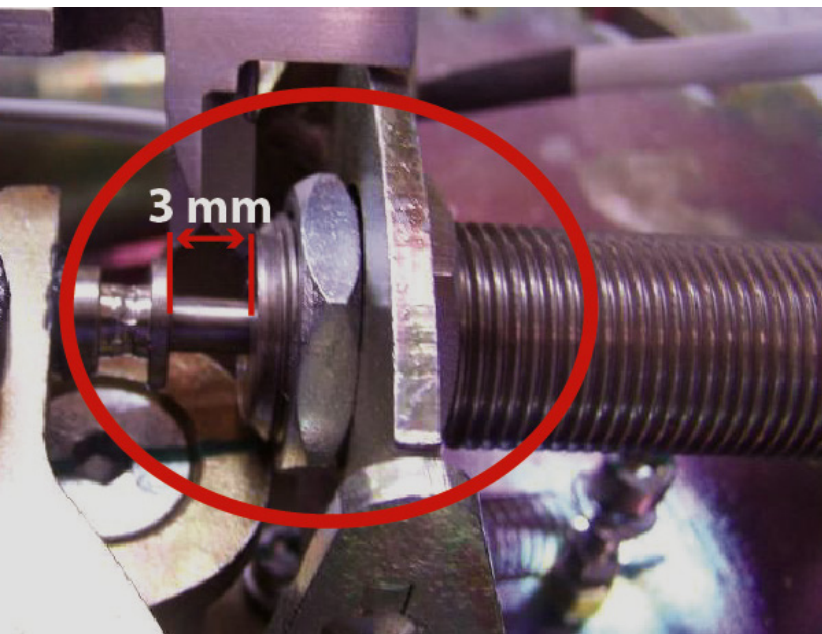

Once the adjustment is done, tighten the stop screw while holding the dial steady with the other hand.

Caution! Dial is very sensitive. It must be adjusted carefully in small increments.



Caution! To prevent damage due to bottoming out of the damper during operation, ensure that there is approximately 3 mm. clearance between the damper head and the body when the damper arm is fully pushed in. Use loctide on damper mounting nuts to prevent loosening by vibration when clearance adjustment is performed.

6. POST INSTALLATION CHECKLIST

No	Item to Check	✓	Remarks
1	Installation surface is flat, even and sufficiently strong		
2	All wiring is routed and connected properly		
3	 All AC power lines are properly insulated and grounded		
4	Turnstile is positioned and mounted correctly and firmly		
5	All anchoring bolts are secured in place with chemical plaster.		
6	All anchoring hardware tightened properly (no loose nuts/bolts etc, turnstile is firmly mounted on the surface).		
7	All arms, covers, panels, readers etc. are mounted correctly		
8	No physical damage or irregularities (dents, scratches, broken items etc.)		
9	When powered up all indicators are normal, solenoids locked, buzzer initial beep is heard, rotor/panel in standby position)		
10	Turnstile allows passage in A direction when contact is given on Input A and Gnd. Opposite side indicator turns red until rotation complete.		
11	Turnstile allows passage in B direction when contact is given on Input B and Gnd. Opposite side indicator turns red until rotation complete.		
12	Turnstile rotor (or panel) operates quietly, smoothly and returns to center (standby) position without bouncing.		Adjust damper if rotor is bouncing or too stiff.
13	In Emg (emergency) mode turnstile allows free passage in both directions while buzzer is heard.		
14	When power is cut off, turnstile allows free passage in both directions by pushing		Standard fail-safe configuration. Fail-locked option is available.
15	 AC potential between turnstile ground and neutral is less than 0.5V. Good continuity (0 Ohm) between chassis and ground.		Unit is properly grounded.

7. SERVICE AND MAINTENANCE

7.1 Maintenance Instructions

7.1.1 Recommended User Maintenance

- Periodically wipe the turnstile exterior with a clean, damp and soft cloth to keep it free of dust.
- Inspect external mounting screws, panels, arms etc. once every three months or as required to ensure that there are no loose, worn out or damaged items. If there are loose or damaged items contact your authorized dealer or Ozak.
- Check that the turnstile is firmly anchored on the surface.(No loose or damaged anchoring).
- Check that all mechanical movement is smooth and quiet with no unusual noise, rattling etc.
- Inspect electrical cables and connections for any damage, water contamination, loose connections or wear. Contact your authorized dealer or the manufacturer if any problem is detected.
- Ozak uses only the finest quality certificated steel obtained from reputable suppliers for maximum corrosion resistance and strength. During our manufacturing process we take all the required steps to ensure that the finished products have excellent corrosion resistance. Depending on the environmental conditions, there may be staining issues on some turnstile surfaces in outdoor installations if regular cleaning and maintenance is not performed. On 304 and higher grade steel surfaces, these stains are not actual rust, but only accumulation of airborne particles sticking on the surfaces. These type of stains can be cleaned off and prevented by periodic maintenance recommended below.
- Cleaning the turnstile surfaces by wiping with a clean, dust and grit free absorbent cloth is effective in most cases. Harsh abrasives should never be used on polished metal surfaces. Commercially available appropriate metal polishing compounds can be used for removal of tougher stains. The recommended frequency of cleaning depends on the local environment as explained in table below.

Environment	Type 304	Type 316
Seafront	Frequently as required	Monthly
Coastal (Within 5 km of the coast)	Frequently as required	6-12 months
Industrial and urban	3-6 months	6-12 months
Suburban Rural	Annually or as required by experience	
Internal	As required to maintain appearance	

-  Do not wash the turnstile with pressurized water.
- There are no user serviceable items inside the turnstile. Do not attempt to do repair work such as lubrication, part replacement or adjustments inside the unit. All such work must be performed by qualified technical personnel only!

7.1.2 Periodic Maintenance by Technical Service Personnel

Full Height Turnstiles	Maintenance Item	Period	Recommended Action
General	Anchoring nuts and bolts	12 Month	Check/ tighten if required
	Top cover / Lock/ Seals and drainage	12 Month	Check
	Rotor arms/ bolts	12 Month	Check/ tighten if required
	Rotor bottom bearing	12 Month	Check + Grease
	Rotor coupling and connections	12 Month	Check
Mechanism Assembly	Main rotor shaft	12 Month	Check + Lubricate
	Clamp spring, damper arm bearing (manual type)	12 Month	Check
	Lock levers and springs	12 Month	Check (free movement)
	Solenoids	12 Month	Check
	Ratchet mechanism and spring	12 Month	Check (free movement)
	Hydraulic Damper (Manual type)	12 Month	Check + Adjust
	Hydraulic damper arm bearing	12 Month	Check / replace if required
	Motor (Motor driven type)	12 Month	Check
	Motor pulley and drive belt (Motor driven type)	12 Month	Check
	Mechanism mounting nuts and bolts	12 Month	Check
Electrical Components	Mechanism Bearings	12 Month	Check
	Power connections, wiring and grounding ⚠	12 Month	Check
	Electronic Control Board	12 Month	Check + Clean Dust
	Positioning photosensor	12 Month	Check + Clean Dust
	Wiring and connectors	12 Month	Check
	Motor Driver Board (Motor driven type)	12 Month	Check + Clean Dust
	Indicators and buzzer	12 Month	Check

7.2 Trouble Shooting and Repair Guide

Description of Fault	Possible Cause	Recommended Action
No power. (indicators, buzzer, locks off)	<ol style="list-style-type: none"> 1. No AC power supplied to unit. 2. Loose power cable 3. Blown fuse 4. Faulty power supply unit 	<ol style="list-style-type: none"> 1. Restore AC power. 2. Connect power cable. 3. Replace fuse (see 2.2) 4. Replace power supply unit
Rotor freewheels in both directions when power is on while buzzer sound is heard.	<ol style="list-style-type: none"> 1. Emergency input jumper or relay contact is open (if indicators are green) 2. Loose or faulty photosensor in mechanism (if indicators are red with periodic beep) 3. Faulty control board 	<ol style="list-style-type: none"> 1. Connect Emg. jumper or NC alarm relay on Emg-Gnd 2. Tighten, repair sensor connection/ replace sensor 3. Replace control board
Note: Ensure Emg. terminal is not activated and dip switches 3 and 4 are off Turnstile does not allow passage when input contact is given-buzzer heard	<ol style="list-style-type: none"> 1. Restricted lock lever movement (due to foreign object such as cable, gummed lubricant etc.) 2. Sticky solenoid 3. Faulty control board 4. Misaligned/bent photo sensor in motorized units 	<ol style="list-style-type: none"> 1. Repair lever mechanism 2. Replace solenoid 3. Replace control board 4. Adjust photo sensor (motorized units)
Rotor/arms do not return to center (standby) position following a passage	<ol style="list-style-type: none"> 1. Loose or broken clamp spring 2. Over damped hydraulic damper setting 	<ol style="list-style-type: none"> 1. Re-install / replace clamp spring 2. Adjust hydraulic damper (see 5.5)
Rotor bounces back and forth following a rotation, fails to settle in rest position smoothly	<ol style="list-style-type: none"> 1. Under damped hydraulic damper setting 2. Worn out / faulty hydraulic damper 	<ol style="list-style-type: none"> 1. Adjust hydraulic damper (see 5.5) 2. Replace and adjust hydraulic damper
Turnstile fails to lock/ free wheels following passage	<ol style="list-style-type: none"> 1. Dislocated, broken lock lever spring 2. Solenoid failure 3. Loose or faulty photo sensor 	<ol style="list-style-type: none"> 1. Repair/ replace lock lever spring 2. Replace solenoid. 3. Re-connect, replace photo sensor

Description of Fault	Possible Cause	Recommended Action
Rotor gets stuck intermittently during rotation	1. Loose or broken ratchet spring	1. Re-install/ replace spring
No response to input/reader device. No access	1. Loose/incorrect reader connection 2. Reader fault 3. Faulty control board	1. Check/repair reader connections 2. Replace faulty reader/input device 3. Replace control board
No passage confirmation contact out of control board	1. Loose connection at output terminal 2. Faulty control board	1. Repair connection 2. Replace control board
Turnstile free wheels in one direction	1. Dip switch 3, 4 might be set for free passage (see 5.4.2) 2. Loose solenoid connector 3. Loose lock lever spring 4. Jammed lock lever	1. Set dip switches 'off' 2. Re-insert connector 3. Repair lock lever spring 4. Repair lock lever
Turnstile unlocks upon input but motor does not run (motorized models)	1. Loose motor/ motor driver board connection 2. Tripped motor driver protection circuit breaker or blown fuse 3. Faulty motor driver board 4. Faulty motor	1. Repair/ tighten connection 2. Do a power off reset/ replace blown fuse 3. Replace motor driver board 4. Replace motor
Motorized rotor keeps moving/ fails to stop in middle position.	1. Loose photo sensor connector 2. Misaligned, bent or contaminated photo sensor 3. Faulty photo sensor	1. Repair/tighten photo sensor connector 2. Adjust/ clean photo sensor 3. Replace photo sensor
Motorized rotor turns too slow and times out/ alarm activated.	1. Too low motor speed setting on motor driver board 2. Loose or oil contaminated drive belt slipping	1. Increase motor speed (turn speed control in ccw direction) on motor driver board 2. Clean/ tighten drive belt

LOCK LEVER MOVEMENT

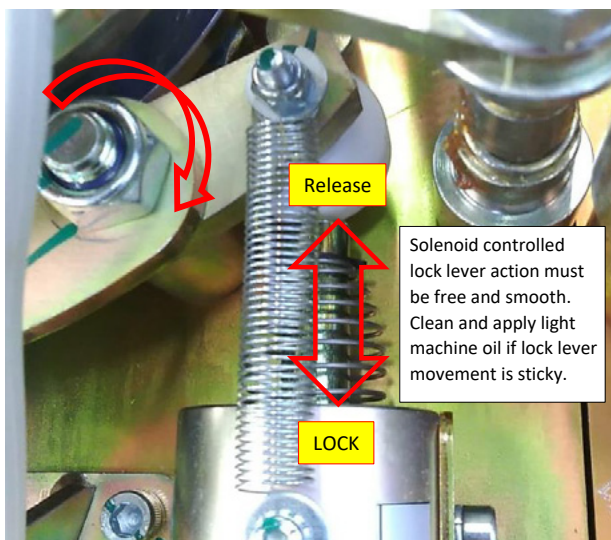

PHOTOSENSOR ALIGNMENT

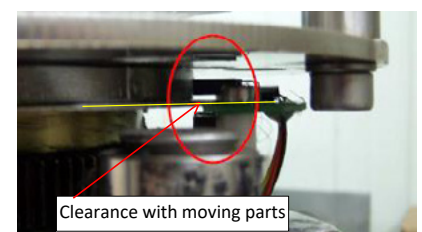
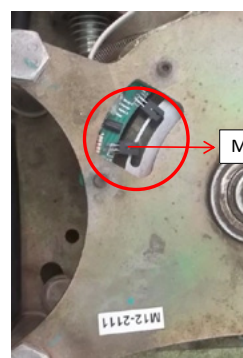
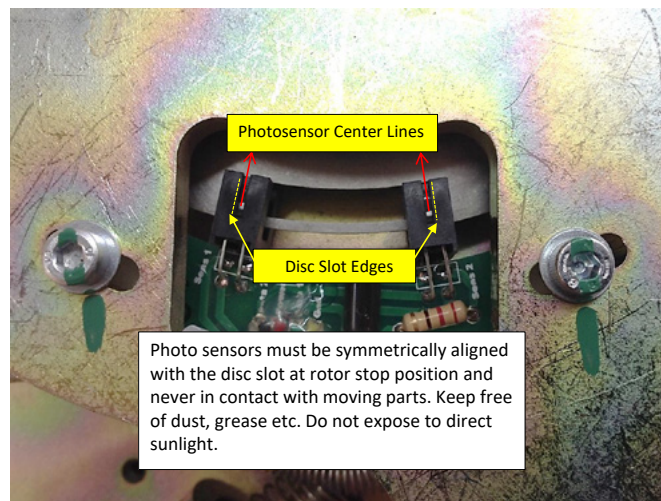

7.3 Mechanism Assembly Exploded Diagrams

EXPLODED DIAGRAM (STANDARD MECHANISM)

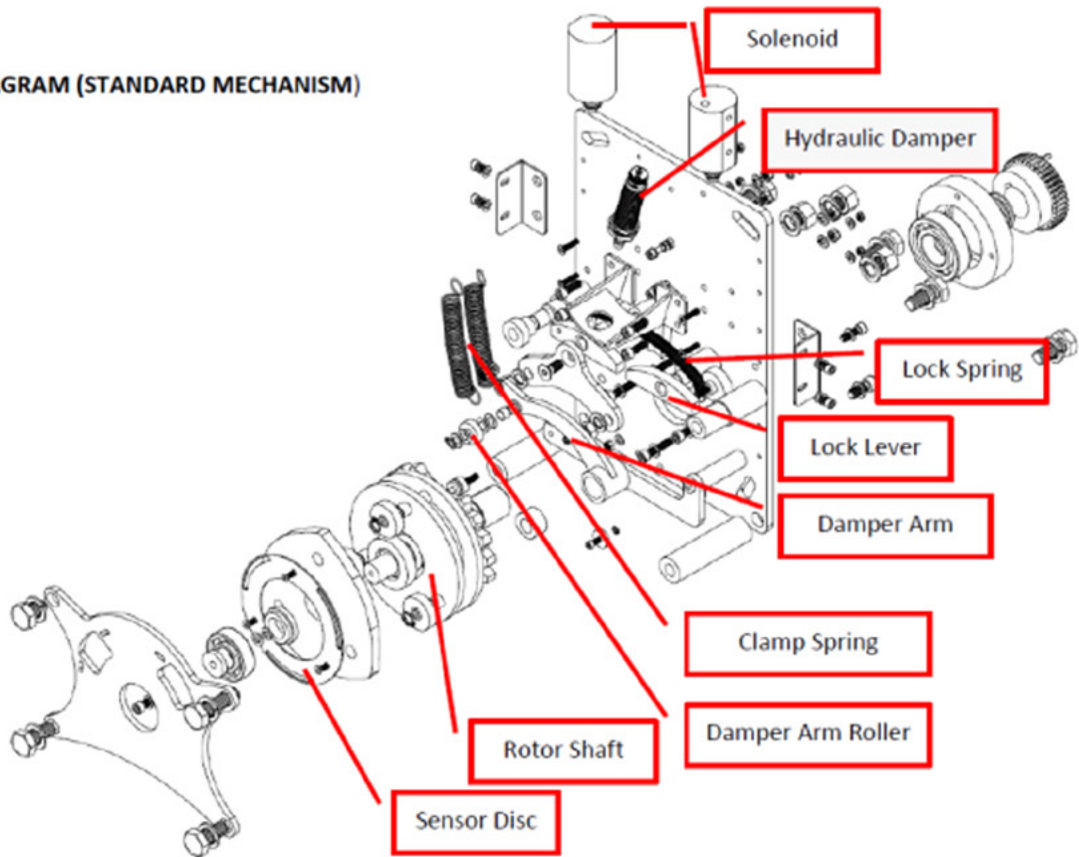

EXPLODED DIAGRAM (MOTORIZED MECHANISM)

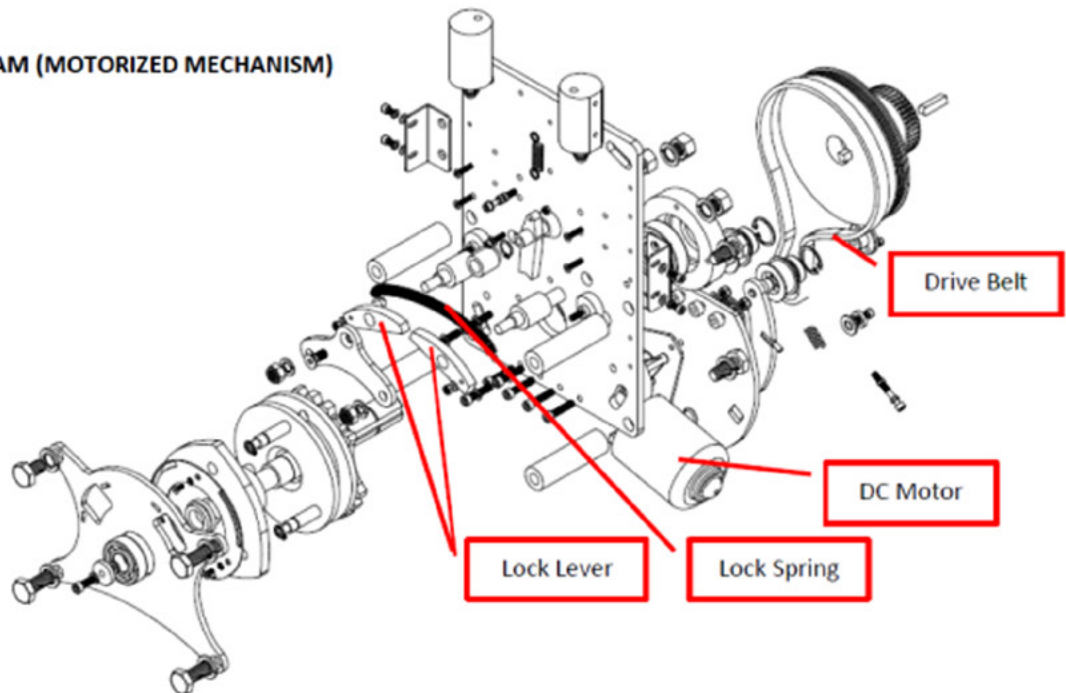

8. LIST OF COMMON REPLACEMENT PARTS

Ref.	Description	Part Code	Standard	Motorized
1	Arm Cap (Stainless Steel)	20 02 02 0323	✓	✓
2	Arm Cap (Plastic)	20 02 03 0027	✓	✓
3	Bearing Ball	10 00 10 0023	✓	✓
4	Clamp Spring (3- Wing Models)	20 02 07 0013	✓	
	Clamp Spring (4-Wing Models)	20 02 07 0029	✓	
5	Couplin	20 03 01 0399	✓	✓
6	Direction Photosensor for TRN 1203 / TRN 1901	30 01 14 0006	✓	✓
7	Down Light (Led)	10 09 02 0001	✓	✓
8	Hydraulic Damper	10 02 00 0001	✓	
9	Hydraulic Damper Bearing (608)	10 00 10 0001	✓	
10	Indicator (Part number varies depending on serial number)	----	✓	✓
11	Lock Lever	20 02 00 0041	✓	
	Lock Lever	20 02 00 0098		✓
12	a) TRN1203	30 01 01 0025	✓	✓
	b) TRN1901	30 01 01 0028	✓	✓
	c) TRN2101S/E	30 01 01 0032/30 01 01 0034	✓	✓
13	Microprocessor (Firmware code must be specified with order)	10 01 23 0001	✓	✓
14	Motor (24V DC / 60W)	10 01 34 0001		✓
15	Motor Belt	10 04 19 0004		✓
16	Motor Driver Board (MC 24 SM)	30 01 03 0012		✓
17	SMPS (50W / 24V)	10 01 35 0017	✓	
18	SMPS (100W / 24V)	10 01 35 0013		✓
19	Solenoid (5V)	30 01 10 0005	✓	✓
20	Magnetic Encoder for TRN 2101	30 01 05 0050	✓	✓

⚠ Use only original OZAK replacement parts!



Note: Please provide serial number of the turnstile when ordering replacement parts. Part specifications can vary depending on the manufacturing date and optional features.

9. CE DECLARATION OF CONFORMITY AND WARRANTY

9.1 CE Declaration of Conformity

CE UYGUNLUK DEKLARASYONU / CE DECLARATION OF CONFORMITY



ÜRETİCİ FİRMA/
MANUFACTURER COMPANY : ÖZAK GEÇİŞ TEKNOLOJİLERİ SANAYİ TİC. A.Ş.
ADRES/ADDRESS : ÇUHANE CAD. NO: 130 41080 KÖSEKÖY/KOCAELİ/TÜRKİYE

Aşağıda adı geçen ürünlerin üretimi, kontrolü ve son değerlendirmeleri ÖZAK tarafından gerçekleştirilmektedir.
Manufacturing, control and final assessment of the below mentioned products are done by ÖZAK.

ÜRÜN LİSTESİ/LIST OF PRODUCTS

Açıklamalar/Explanations: TURNİKELER (BEL TİPİ TURNİKELER / BOY TİPİ TURNİKELER / HIZLI GEÇİŞ TURNİKELERİ /
ENGELLİ GEÇİŞ TURNİKELERİ / YÜKSEK GÜVENLİK TURNİKE VE KAPILARI / YARIM BOY TURNİKELER /
GEÇİŞ KAPILARI / SPC ÖZEL DİZAYN TURNİKELER / SERBEST GEÇİŞ TURNİKELER)
TURNSTILES (WAIST HEIGHT TURNSTILES / FULL HEIGHT TURNSTILES /
SPEED GATES TURNSTILES / REVOLVING WING GATES TURNSTILES /
SECURITY DOORS AND TURNSTILES / HALF HEIGHT TURNSTILES / PEDESTRIAN GATES /
SPECIAL DESIGN TURNSTILES / FREE PASSAGE (RETAIL LINE) TURNSTILES)

İlgili Direktifler/Relevant Directives:

(2006/42/EC) Makine Emniyet Yönetmeliği / Machine Safety Directive,
(2014/30/EU) Elektromanyetik Uyumluluk Yönetmeliği / Electromagnetic Compatibility Directive

HARMONİZE STANDARTLAR'a Göre Uygulanmış Yönetmelikler/
Regulations applied according to HARMONIZED STANDARDS

:EN ISO 12100:2010, EN 60204-1:2018, EN ISO 13857:2008,
EN ISO 14120:2015, EN 349:1993/A1:2008, EN 61000-6-1:2019,
EN 61000-6-3:2007/A1:2011/AC:2012

ÖZAK GEÇİŞ TEKNOLOJİLERİ SANAYİ TİC. A.Ş. yukarıda listesi verilen ürünlerin 2006/42/EC Makine Yönetmeliği ile 2014/30/EU Elektromanyetik Uyumluluk Yönetmeliği ve ilgili harmonize standartların gerekliliklerini sağladığını ve uygunluğunu beyan eder.

ÖZAK GEÇİŞ TEKNOLOJİLERİ SANAYİ TİC. A.Ş. hereby declare that the above listed products satisfy and comply with the requirements of Harmonised Standards for 2006/42/EC Machinery Directive and 2014/30/EU Electromagnetic Compatibility Directive.

İsim/Name : ÖZER ÖZALP Ünvan/Title : GENEL MÜDÜR/GENERAL MANAGER
Yer ve Tarih/Place and Date : KOCAELİ / 10.03.2022 İmza/Signature



Warranty Certificate

BRAND NAME :

MODEL :

DATE OF DELIVERY :

WARRANTY PERIOD :

SERIAL NUMBER :

MANUFACTURER : ÖZAK GEÇİŞ TEKNOLOJİLERİ SANAYİ TİC A.Ş.
ADDRESS : Çuhane CD. NO: 130 41080 KÖSEKÖY / KOCAELİ / TURKEY
PHONE&FAX : +90 262 373 48 48 Pbx.
E-MAIL : ozak@ozak-t.com
WEB : www.ozak-t.com



TS EN ISO 9001 : 2015



9.3 Warranty Terms and Conditions

1. Warranty period starts after the date of purchase of the goods and continues for twenty-four (24) months against manufacturing defects. Warranty coverage is in form of supplying replacement parts free of charge.
2. Availability of the spare parts by the manufacturing company is guaranteed for ten (10) years following the manufacturing date of the product.
3. Any tampering, failures resulting from unauthorized modification or repair attempt and shall void the warranty.
4. Expiration time for the warranty of the parts replaced within the warranty period is the same as that of the product.
5. When the product fails within the warranty period, duration of repair is added to the warranty period.
6. Manufacturing company supplies required replacement parts to repair defects and failures during the warranty period in accordance with the terms stated herein. The parts are supplied to the authorized dealer/service center which has sold the product to end user.
7. It is the user's responsibility to check that technical services are carried out in accordance with the terms stated herein.
8. The user must retain the warranty certificates, serial numbers and present to the authorized service personnel when required. Serial number is required when replacement parts are ordered from the manufacturer.
9. Users are expected to sign the failure report/service forms that are filled after service/maintenance work performed under the warranty coverage.
10. In case any dispute or problem related to the warranty is not resolved by the manufacturer, users can apply to the Republic of Turkey Ministry of Industry and Trade, Directorate General of Protecting Consumer Rights and Competition.
11. All replacement parts sold by Ozak are warranted for a period of one year following the date of purchase, excluding failures resulting from physical damage, incorrect installation, misuse, tampering and similar reasons beyond manufacturers control.
12. The specified warranty periods and MCBF's of our products are based on the condition that the product is properly installed, operated and maintained in accordance to the recommended periodic maintenance plan of the manufacturer as outlined in the relevant technical documentation of the product. Such documentation is provided with the product or it can be obtained from the manufacturer.

9.4 Cases Excluded from the Coverage of Warranty

1. Any tampering or damage on warranty certificate or serial numbers and labels that prevent the identification of the product.
2. Any modifications, addition of accessories and parts, or replacement of parts without approval of manufacturer fall within the scope of tampering with the system, therefore terminates liability of the manufacturing company.
3. Warning signs, stickers, scratches, paint damage, wear and tear, externally caused stains etc.
4. Any damage and failure resulting from any of the conditions listed below are not covered by warranty:
 - a. Misuse, abuse, deliberate act or negligence,
 - b. Any damage, scratches or breakage of glass, acrylic, polycarbonate etc. parts,
 - c. Failures caused by improper installation, wiring, isolation, short circuit, power surge, incorrect wiring and voltage applications, improper grounding, change of phase group, induction current effects,
 - d. Maintenance, repair, additions or replacement of parts and accessories or moving the turnstiles from original place by unauthorized personnel or company, and lack of periodic maintenance of the product,
 - e. Shipping and handling and installation related damages,
 - f. Failures caused by exposure to unsuitable operating/environmental conditions for the stated technical specifications of the product (intended use, temperature range, IP grade etc.),
 - g. Failures caused by leakage of water into the internal parts of the product due to application of pressurized water, unauthorized modification, improper installation,
 - h. Damage and failure caused by lightning, flood, fire, storm, hurricanes, earthquake and similar natural disasters,
 - i. Accidents that occur at the location where the products are installed,
 - j. Damages/failures caused by pests such as rodent damage to wiring,
 - k. Damages that occur as a result of circumstances beyond reasonable control of the manufacturer or the user (armed conflicts, civil unrest, blockade, revolution, insurrection, mobilization, looting etc.),
 - l. THE DAMAGE OR FAILURES OCCURRING DUE TO FEEDING OF EXTERNAL DEVICES (CARD READERS, TERMINALS, INDICATIONS, COMMUNICATION DEVICES, ETC.) FROM THE CONTROL BOARD OR POWER SUPPLY UNIT INSIDE THE TURNSTILE.



ÖZAK



Google Map



+90 262 373 48 48

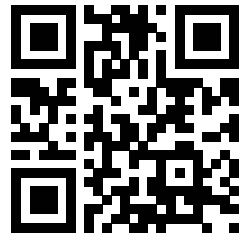

www.ozak-t.com

Çuhane Cd. N: 130
Köseköy / Kartepe / Kocaeli / TÜRKİYE

T: +90 262 373 48 48
F: +90 262 373 48 48
E: ozak@ozak-t.com

KK-1302-0002 R(9)
Y.T.13.06.2022