

Honeywell

IntelliPath™ Series 4G GSM Communicator

Auto-selects Optimum GSM path – 2G, 3G, or 4G

IGSMV4G/IGSMVCN4G

Internet and GSM Communicator

supports two-way voice

Installation and Setup Guide



Table of Contents

SECTION 1: General Information	1-1
System Overview.....	1-1
Introduction	1-1
General Information.....	1-1
System Features.....	1-2
About AlarmNet-i Internet Application	1-2
Encryption	1-2
Remote Services	1-2
Modes of Operation	1-3
ECP Mode.....	1-3
Zone Trigger Mode.....	1-3
4204 Mode and Two-4204 Mode	1-3
Supervision Features	1-4
Antenna	1-4
Specifications.....	1-5
Compatibility.....	1-6
Compliance	1-6
SECTION 2: Mounting and Wiring	2-1
Determine the Signal Strength and Select a Location	2-1
Mounting the Communicator	2-2
Mounting Procedure, IGSMV4G (no rear tamper switch).....	2-2
Mounting Procedure, IGSMVCN4G (with rear tamper switch).....	2-3
Wiring the Communicator	2-4
Wiring for two-way voice.....	2-4
Wiring for ECP, 4204 and Two-4204 Modes	2-5
Wiring for Zone Trigger Mode	2-6
Wiring the Fault Relay.....	2-7
Internet Connection.....	2-7
Power Connections and Options	2-8
Powering the Communicator	2-8
Backup Battery Connection	2-9
Initial Power-Up Sequence	2-9
SECTION 3: Programming the Communicator	3-1
General Information	3-1
Using the AlarmNet Direct Website	3-1
Using a 7720P Programming Tool.....	3-1
Using the Control Panel Programming Mode	3-2
Programming Conventions	3-3
ECP Mode Programming.....	3-3
ECP Status Codes.....	3-9
Alternative Modes (Zone Trigger, 4204 and Two-4204)	3-9
Zone Trigger Mode.....	3-9
4204 Emulation Mode	3-10
4204 Emulation Mode Options	3-10
Alternative Mode Programming	3-11
Exiting Programming Mode	3-20
Setting Factory Defaults.....	3-20
SECTION 4: Registration	4-1
Registering the Communicator	4-1
Register through the AlarmNet Direct Website	4-1
Register using the Tamper Switch	4-2
Register using the Programming Tool	4-2

Replacing an existing communicator	4-3
Register by Phone	4-3
SECTION 5: Programmer Keyboard Commands	5-1
Programmer Keyboard Commands.....	5-1
Identification Displays	5-1
GSM Status Displays	5-2
System Status Displays.....	5-4
SECTION 6: Network Diagnostics.....	6-1
Running Network Diagnostics	6-1
Possible Errors Running Network Diagnostics.....	6-2
Appendices	A-1
Appendix A : Summary of LED Operation	A-1
Appendix B : Central Station Messages	B-1
Appendix C : Glossary.....	C-1
Summary of Connections Diagram.....	Inside Back Cover

General Information

System Overview

Introduction

Congratulations on your purchase of Honeywell's IGSMV4G/IGSMVCN4G Internet and GSM communicator (henceforth referred to as IGSMV4G, or IGSMVCN4G in Canada). It represents the latest and most innovative communication technology for the security industry and uses the most sophisticated encryption to ensure the highest level of security for your customer.

The new 4G connectivity brings faster GSM data transfers with lower latency (response time); together it results in speedier data transfers.



The communicator requires an AlarmNet-i account. For new installations, please obtain the account information from the central station prior to programming this communicator. For replacement installations, the AlarmNet-i account is created automatically when the communicator is registered.

In addition to alarm reporting, the communicator provides two-way voice communications with the central station (when used with Honeywell's [AVS Audio Verification System](#)) and provides upload/downloading capability of Honeywell's control panel data over the Internet (via the AlarmNet-G network), using GSM (Global System for Mobile) technology.

UL/ULC Two-way voice has not been evaluated by UL/ULC.

NOTE: Two-way voice is not compatible with Honeywell Commercial Control Panels (such as the VISTA-128/250 series).

General Information

The IGSMV4G communicates via the Internet (when service is available) and switches to GSM service when the Internet is not available. When both services are unavailable, the communicator provides a third way to communicate by sending a transmission via SMS (Short Message Service) also known as a text message.

ULC SMS has not been evaluated for ULC central station communication.

In normal operation (with Internet connectivity), the IGSMV4G communicates from your customer's network connection to the Honeywell Network Operations Center, (NOC) via the AlarmNet-i network. The NOC receives data and routes the information to the Central Station of your choice, based on the account number you assign to the communicator. Note that your Central Station needs to give you the account number. The same account number is used for both Internet and GSM transmissions. If your current Central Station is capable of receiving signals from the Honeywell NOC, they are capable of receiving signals from the communicator.

If, for some reason, Internet connectivity is not available, (for example, your customer's ISP is off line or disconnected), the communicator will transmit signals via the AlarmNet-G (GSM) cellular network, which uses the GPRS (General Packet Radio Service) to complete these transmissions. These transmissions are sent to the Honeywell NOC and then forwarded to your Central Station exactly the same way as if they were received via the Internet.

If the Internet AND GPRS (part of the GSM cellular network) are both unavailable, the communicator will attempt to send the transmission via SMS (Short Message Service), also

known as a text message. If all three methods fail, the message will not be sent via this device.

ULC

The IGSMV4Gs' Internet channel has been evaluated for active communication and Level A3 channel security for burglary. The GSM Cellular channel is employed for supplemental use; it may be used in conjunction with a listed DACT to provide passive communication when using P2 channel security for burglary (when Internet connection is not available).

System Features

Basic features of the communicator include:

- Remote Services allow the end user to access their security system from their computer via a website. Availability of this service is controlled by the dealer via the web-based programming tool on the AlarmNet Direct website. Once enabled, remote access can be programmed via web or 7720P programming tool.
- Supports dynamic or static IP addressing, and installs behind firewalls without compromising network security.
- Quick connection to compatible Honeywell series control panels
- Simple programming using a 7720P programming tool
- Reports fire, burg, and status messages via the Internet
- Reports messages via AlarmNet-G as backup to Internet reporting
- Allows uploading and downloading of control panel data over the Internet
- Supports remote control of alarm systems via Remote Services feature
- Two-way voice capability

About AlarmNet-i Internet Application

AlarmNet-i is a fully encrypted, secure method of delivering alarm messages from a protected premise to an AlarmNet equipped central station. An Internet Communicator transmits status, supervisory, and alarm messages to the AlarmNet Control Center using a broadband Internet connection.

The AlarmNet Control Center identifies, validates, and forwards the messages to the appropriate AlarmNet central station. AlarmNet-i has an unlimited account capacity.

Encryption

The communicator uses 256 bit AES (Rijndael) encryption (which is required for certain government installations). The AlarmNet-i AES Encryption Software Module Version 1.0 contained in the Honeywell products has NIST approval. Listings for this approval can be found at <http://csrc.nist.gov/cryptval/aes/aesval.html> and search for "Certificate number 127."

UL

The IP and GSM signaling paths are suitable for encrypted line security when programmed for 1 minute IP/GSM Fault Times. The system configurations are not suitable as a Dual Line Signal transmission system.

Remote Services

Honeywell now offers a new series of web based services that provides consumers with the ability to communicate with their security system remotely in a number of ways. These new web services will allow users to:

- Access their security system from a computer via a website (Remote Access feature)
- Receive email and text message notifications of system events (Multi-Mode feature)
- Perform system functions and receive confirmations using text messages (SMS feature)

Dealers will initially enroll their customers for web services during account programming through the AlarmNet Direct website. The features that can be enabled include Remote Access and Multi-Mode. Once enabled, the specific programming fields associated with these

features can be programmed into the communications device either remotely using the AlarmNet Direct website or locally using the 7720P local keypad programming tool.

UL Remote Access and Multi-Mode have not been evaluated by UL.

Modes of Operation

The communicator provides four modes of operation so it can be used with various types of control panels, as summarized below.

ULC Only ECP Mode has been approved for ULC installations.

UL Only ECP Mode and Zone Trigger Mode have been evaluated.

ECP Mode

- This mode is for Honeywell control panels that support ECP communication
- The communicator connects to the control panel's keypad terminals and provides 2-way communication with the control panel using ECP messaging
- The control panel treats the communicator as an ECP device, so ensure to program the control panel with the communicator's device address
- Reports are sent in Contact ID format
- The communicator also supports two hardwire zone trigger inputs (zones 6 and 7)

UL

- Opening and Closing ring back is fully supported.
- For the IGSMV4G, only the V+ inverted, V- non-inverted, and EOL options have been evaluated.

Zone Trigger Mode

- This mode is for use with control panels that do not support ECP communication nor 4204 Relay Modules
- The communicator provides six input zones
- Each zone can be configured for +V, -V, or EOLR triggering

UL: For the IGSMV4G, only the V+ inverted, V- non-inverted, and EOL options have been evaluated.

- Each zone can be programmed for inverted operation, delayed reporting, and restoral reporting
- Zone 1 input can distinguish between pulsed and steady signals and report fire or burglary alarms respectively
- Zone 1 can also be programmed to report LYNX panic (if used with LYNX control)

UL: This feature has not been evaluated by UL.

- Reports are sent in ADEMCO High-Speed format

UL Opening and Closing ring back is supported by the control panel's digital dialer.

4204 Mode and Two-4204 Mode

- This mode is for Honeywell control panels that do not support ECP communication, but that do support 4204 Relay Modules
- The communicator connects to the control panel's keypad terminals
- The control panel treats the communicator as 4204 Relay Module(s), so program the control panel accordingly, including setting the module's proper 4204 device address

- 4204 mode provides up to four zone inputs, plus two optional trigger zones, depending on options programmed
- Two-4204 mode provides up to eight zone inputs, depending on options programmed
- Each 4204 zone can be programmed for delayed reporting and restoral reporting
- Reports are sent in ADEMCO High-Speed format

UL – Opening and Closing ring back is supported by the control panel’s digital dialer.
– 4204 Mode and Two-4204 Mode has not been evaluated by UL.

Supervision Features

The communicator provides the following types of supervision and fault detection:

- **Network communication failure:** In the event the AlarmNet network does not hear a supervisory message from the communicator within a specified time, AlarmNet notifies the central station of a communication failure.
- **Communication path failure:** In the event the module detects a communication path failure, both the Central Station and the control panel can be notified of the trouble condition. Both failures are considered true faults when the respective fault times have expired ("GSM Fault Time" and "IP Fault Time" options) provided it has been set to a non-zero value. Notification is sent to the central station upon this expiration. Notification to the panel is controlled by the "Notify Panel Of" option.
(Note, if the "GSM Fault Time" and "IP Fault Time" options are set to zero, faults will not be reported.)
- **Fault output:** Terminal 11 can serve as a fail-safe trigger for communicator fault conditions.
If used, the fault relay will trip when the following conditions occur: tamper*, power loss*, low battery*, battery charger fault*, loss of network connectivity*, the device is not registered and the device is remotely disabled by AlarmNet.
* Alarm reporting for the noted condition must be enabled for it to trigger the fault relay.
- Primary power loss and low battery conditions ("Pwr Loss Rpt," "Low Bat Rpt" options).
- Cover tamper condition ("Tamper Rpt" option).

Antenna

The communicator comes equipped with an internal antenna. This feature provides additional security to the installation by making the device tamper resistant.

UL/ULC External antenna has not been evaluated by UL.



AMPS antennas, such as the 7825-OC antenna, cannot be used with this product.

Specifications

Mechanical:	Dimensions: 8.4" x 8.0" x 1.5" Weight: 2.4 lbs., with battery		
Input Power:	16.5VAC, 40VA transformer, or for ULC installations 12VDC from the control panel. (Honeywell transformer # 1361 included with IGSMV4G.) (Honeywell transformer # 1361CN not included with the IGSMVCN4G.)		
Current Drain:	65mA standby, 380mA active		
Backup Battery:	6V, 3.1AH, (Honeywell # K14139 included with IGSMV4G only.) Expected Battery Life: 5 Years (approx.) Note: The sealed lead acid battery used for backup will have reduced life expectancy when exposed to elevated temperatures. The useful life of the battery at 25°C (77°F) is approximately 4 years. At 35°C (95°F) this will drop to 2 years and at 45°C (113°F) 1 year. Battery life expectancy should be taken into account when locating the radio.		
Fault Relay Output:	Open collector, 12VDC, 0.25W max.		
Positive Trigger Level:	6V or greater = positive trigger. (4V or less = restore.)		
Negative Trigger Level:	4V or less = negative trigger. (6V or greater = restore.)		
RF Frequency:	2G	GSM/GPRS/EDGE	Quad Band, 850/900/1800/1900 MHz
	3G/4G	UMTS/HSPA+	Band V, Band II
RF Output Power:	2G	GPRS	+33dBm, GMSK modulation
		EDGE	+27dBm, 8-PSK modulation
	3G	UMTS	+24dBm, QPSK modulation
		WCDMA	+24dBm, QPSK modulation
	4G	HSPA+	+24dBm, 64 QAM modulation
		WCDMA	+24dBm, 64 QAM modulation
Ethernet:	Network Standard: IEEE 802.3u compliant Data Rate: 10Base-T / 100Base-T with auto detect Ethernet Cable: Cat. 5 (min), MDI / MDI-X auto crossover		
Environmental:	Operating temperature: -20° to +55°C, for UL/ULC installations 0°C to +49°C Storage temperature: -40° to +70°C Humidity: 0 to 95% relative humidity, non-condensing for UL installations 0% to 85%; for ULC installations 0% to 93% Altitude: to 10,000 ft. operating, to 40,000 ft. storage		

Compatibility

For a list of control panels that are compatible with various features of this device, go to:
<http://www.security.honeywell.com/hsc/resources/MyWebTech>.

After logging on, select the applicable communication product, and then select “Compatibility Chart” under Essential Docs.

For UL and ULC Fire and Burglary installations, compatible control panels are:

- Vista-32FB
- Vista-128FBP
- Vista-250FBP
- FA1670C
- FA1700C

For UL and ULC Fire and Burglary installations, compatible receivers are:

- MX8000 (UL – can be used for secondary reporting in ECP mode and Zone Trigger mode. Shall be used for opening and closing ring back with the control panel dialer)
- 7810iR-ENT (UL – must be the primary alarm receiver.)
- Ademco 685

UL

The Automation System must be UL1981 listed.
The IGSMV4G has been evaluated for connection to police station receivers.

ULC

The IGSMVCN4G has only been evaluated for communication with listed Model 7810iR-ENT internet receiver and Model MX8000 central station receiver.

Compliance

This device complies with the following ULC Installation Codes and Standards:

1. The Canadian Electrical Code, Part I, Safety Standard for Electrical Installations, CSA C22.1.
2. National Building Code (NBC).
3. Standard for Installation and Services for Fire Signal Receiving Centers and Systems, CAN/ULC-S561-03.
4. Standard for Installation of Fire Alarm Systems, CAN/ULC-S524-06.
5. Standard for Installation and Classification of Burglar Alarm Systems for Financial and Commercial Premises, Safes and Vaults, CAN/ULC-S302-M91.

Mounting and Wiring

Determine the Signal Strength and Select a Location

The communicator must be mounted indoors within the protected premises. When choosing a suitable mounting location, understand that signal strength is very important for proper operation. For most installations using the supplied antenna, mounting the unit as high as practical, and avoiding large metal components provides adequate signal strength for proper operation.

You will use the communicator to determine signal strength in order to find a suitable mounting location.

Note: If the SIM is already activated, the RSSI signal strength indicators will indicate signal strength. If the SIM has not been activated, the firmware in the communicator enables it to communicate with the cellular network towers (without the SIM being activated) so that signal strength measurements can be determined. In this case, you can display the signal strength by simultaneously pressing the MODE and TAMPER switches.
Allow at least 60 seconds for a reading to establish.

RF Exposure

Warning – The antenna(s) used for this transmitter must be installed to provide a separation distance of at least 20 cm from all persons and must not be collocated or operating in conjunction with any other antenna or transmitter.

Note: The communicator must be installed in accordance with the National Electrical Code, ANSI/NFPA 70.



Unshielded, 22 AWG cable is recommended for the communicator power/data wires.

1. Unpack the communicator and open the case by pushing in the two bottom tabs with a screwdriver while separating the case front.
2. Temporarily connect the communicator to the AC transformer or battery.
3. Choose the installation site with the **best signal strength** by observing the signal strength (RSSI) bar graph (refer to *Appendix A* for information about signal strength and status indications). Signal strength should be within 3-5 bars. The best signal strength is usually found at the highest point in the building, near a window.

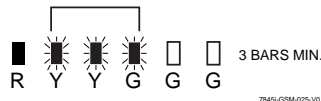

4. Mark the location for the communicator.

Mounting the Communicator

The communicator can be mounted in two ways depending on the installation requirements.

ULC NOTES:

For Commercial Fire installations, the communicator must be mounted to a single or double gang box.

1. Locate the Drilling Template (provided) and align with case back. Drill at the appropriate locations for either single or double gang box.
2. Locate the gang box into the mounting surface, align case back over mounting surface and install using the screws provided. Pass wires/cables through the opening in the gang box and then through the opening in the case back.
3. When all wiring is completed, attach the case front to the case back. Attach the top first then press the bottom section inward until it snaps into place. Secure cover using supplied screw.
4. For Commercial Burglary installations, you must install the rear tamper switch.

UL

The cover must be secured with the supplied screw.

Mounting Procedure, IGSMV4G (no rear tamper switch)

1. Locate the case back over selected mounting position such that the opening in the case back is aligned with the wire/cable opening on the mounting surface.
2. Pass the wires/cable through the opening in the case back, or route through the removable knockouts located on the back cover.
3. Secure the case back to the mounting surface using four screws (supplied).
4. When all wiring is completed, attach the case front. Position the top first, then press the bottom section until it snaps in place. Secure bottom using the supplied cover screw. (This is required for UL installations.)

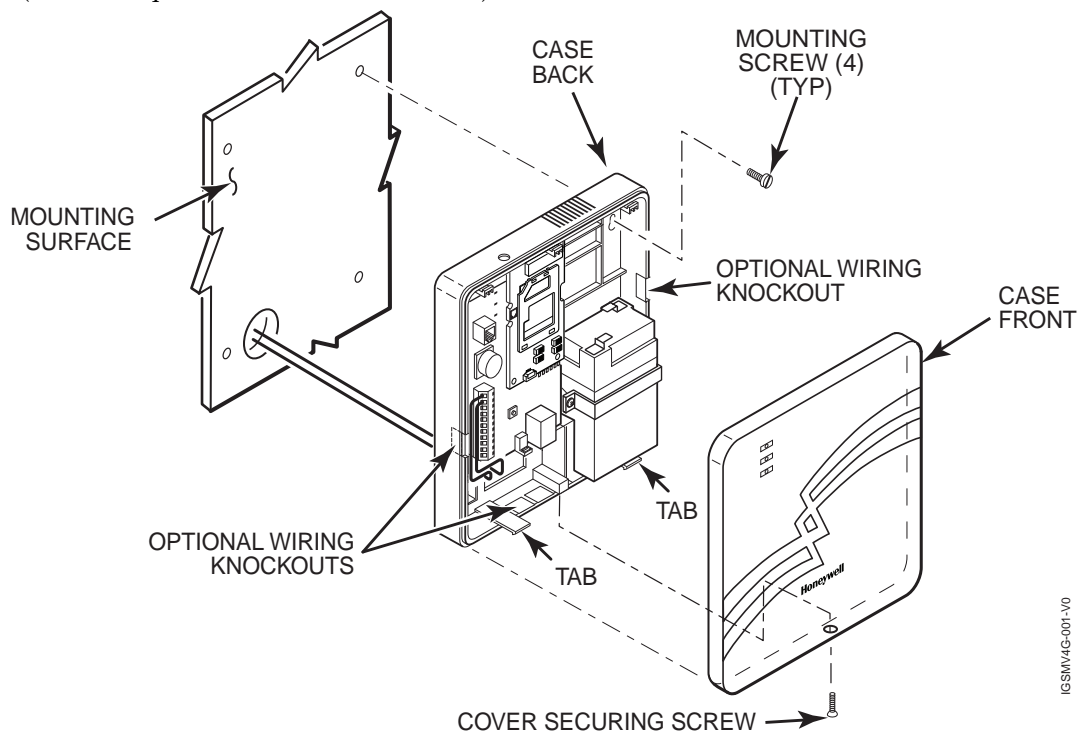

Standard Mounting

IGSMV4G-001-V0

Mounting Procedure, IGSMVCN4G (with rear tamper switch)

For Canadian installations where the rear tamper switch is used, this procedure requires the removal of the printed circuit boards and installation of the tamper screw.

1. Remove the two mounting screws, and standoff from the daughter card, as shown in **Step A** below.
2. Remove the daughter card by pivoting upward, as shown in **Step B** below.
3. Remove the lower printed circuit board by pushing down on the lower tabs and pivoting the board upward, as shown in **Step C** below.

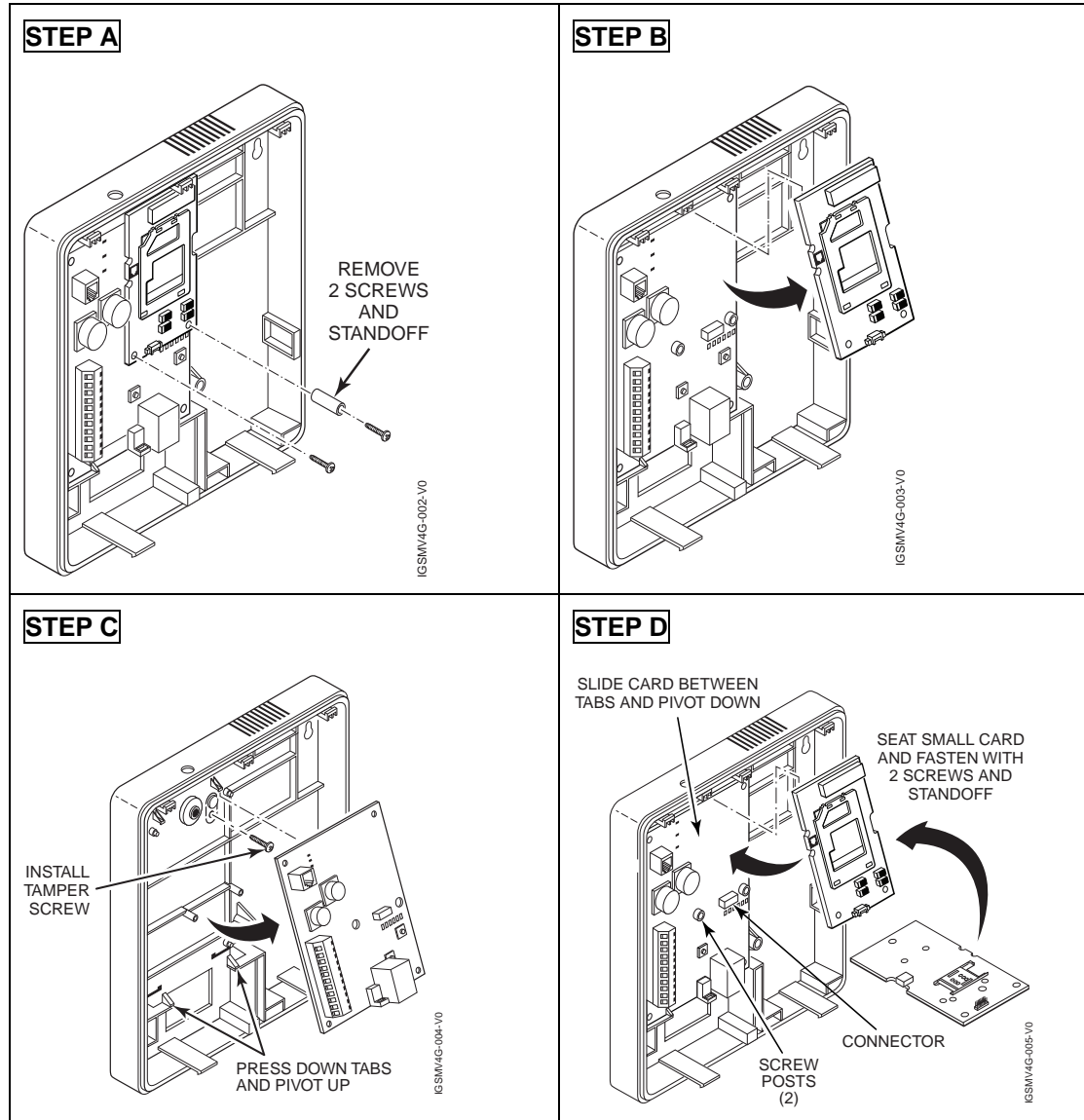

4. Locate the case back over selected mounting position such that the opening in the case back is aligned with the wire/cable opening on the mounting surface.
5. Pass the wires/cable through the opening in the case back, or route through the removable knockouts located on the back cover.
6. Secure the case back to the mounting surface using four screws (supplied).
7. Install the tamper screw (provided), as shown in **Step C** above.
8. Replace lower printed circuit board and then daughter card, as shown in **Step D** above. Be sure to engage receptacle pins by pushing in before securing the daughter card with mounting screws.

When all wiring is completed, attach the case front. Position the top first, then press the bottom section until it snaps in place. Secure bottom using the supplied cover screw.

Wiring the Communicator

UL

- Installation must be in accordance with; the National Electrical Code, UL681 Installation and Classification for Burglary and Hold-Up Alarm Systems, and UL827 for Central-Station Alarm Services.
- The communicator must be connected to a UL Listed dry contact or voltage trigger outputs of a UL Listed compatible control panel.
- All interconnecting wires between the UL Listed control panel and the communicator must be less than 3 feet in length contained in the same room. All interconnecting wiring must be installed in rigid or EMT (where exposed on interior walls) or in flexible metal tubing if run in the walls or ceiling.
- A UL listed control panel must monitor the radio fault output of the communicator. Premises openings and closings should be sent via the UL listed control panel.
- Only ECP mode and Zone Trigger mode have been evaluate by UL.

ULC

For ULC Commercial Fire and Burglary installations, only use the ULC wiring specified in the "Power Connections and Options" topic.

Wiring for two-way voice

The IGSMV4G requires an optional audio cable (GSMV-AUDIO, grey) to support two-way voice using the AVS Base Unit. Note the AVS Base Unit is part of Honeywell's AVS Audio Verification System. This system consist of the AVS Base Unit, Remote Station, and the Remote Station PC board. For detailed information, please refer to the AVS Audio Verification System documentation. Follow the guidelines below for connecting the audio cable.

1. Power down the communicator, control panel and AVS Audio Verification System. (When the communicator is fully wired up, restore power to the communicator, control panel and AVS Audio Verification System.)

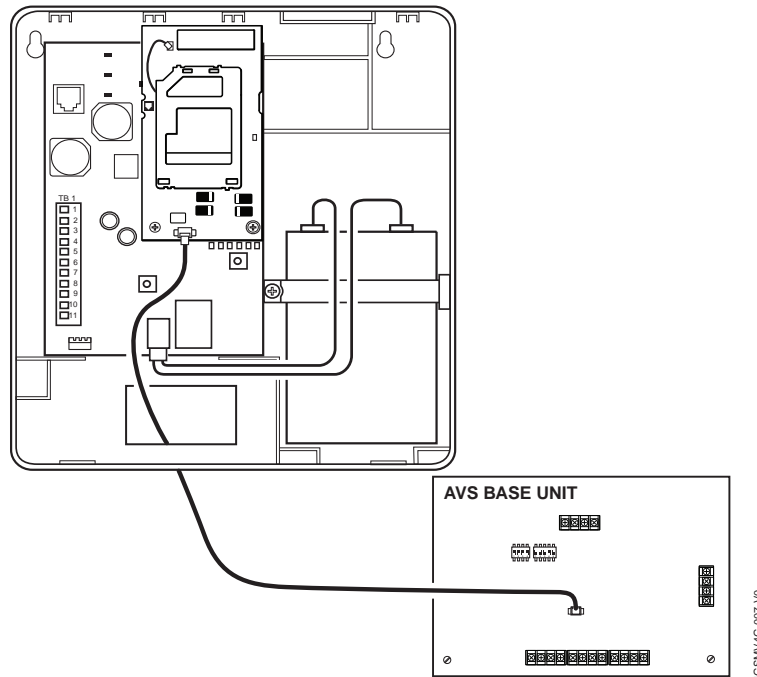

2. Connect one end of the audio cable to the audio connector located on the small PC board.
3. Route the audio cable to the connector on the AVS Base Unit and connect the cable.
4. Ensure the audio cable ends are secured with tie wraps to reduce strain.

Wiring for ECP, 4204 and Two-4204 Modes

Most Honeywell ADEMCO control panels support ECP data communication, (e.g., VISTA-10P, VISTA-15P, VISTA-20P, VISTA-128BP and VISTA-128FBP). However, there are some panels that do not. Check the Installation and Setup Guide for the control panel you are using to see if it supports ECP communication.

Connect the communicator to a compatible Honeywell VISTA control panel's ECP terminals, in parallel with keypads and other peripheral devices such as RF receiver, VIP module, etc. Wire length/gauge limitations are the same for the communicator as they are for keypads and other peripheral devices. To wire the communicator for ECP or 4204 modes, see the figure below and make the following connections:

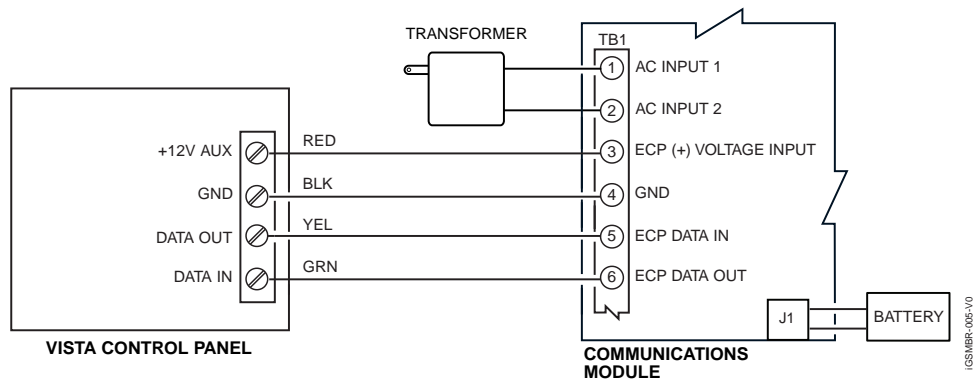

Wiring a VISTA for ECP Mode or 4204 Modes

Wiring for Zone Trigger Mode

To trip a zone using a positive trigger, the voltage level must be:

- 6V or greater = positive trigger. (Levels above +14V may cause damage to the unit.)
- 4V or less = restore.

To trip a zone using a negative trigger, the voltage level must be:

- 4V or less = negative trigger.
- 6V or greater = restore. (Levels above +14V may cause damage to the unit.)

Note: Remember to program the communicator zone for the desired trigger type.

Connect a wire from the triggering source (bell output, voltage trigger, etc.) of the control panel to the zone input of the communicator, and connect a common ground between the communicator and control panel. Examples of zone connections follow:

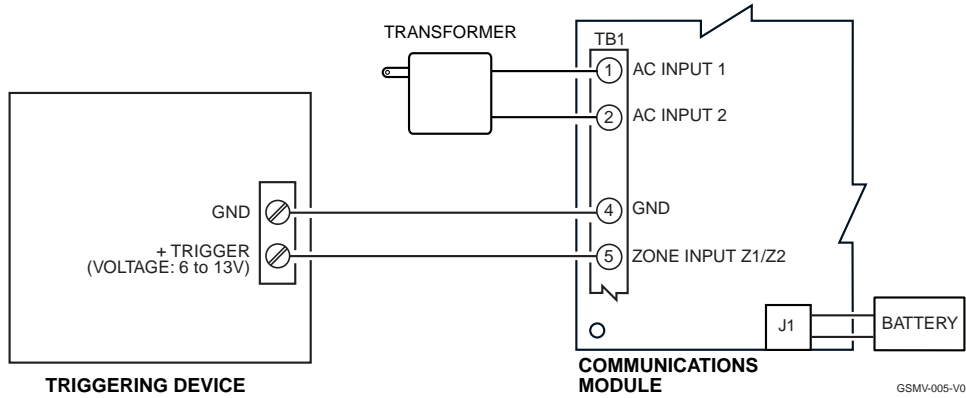

Wiring the Zone 1 Input for a Positive (+) Trigger

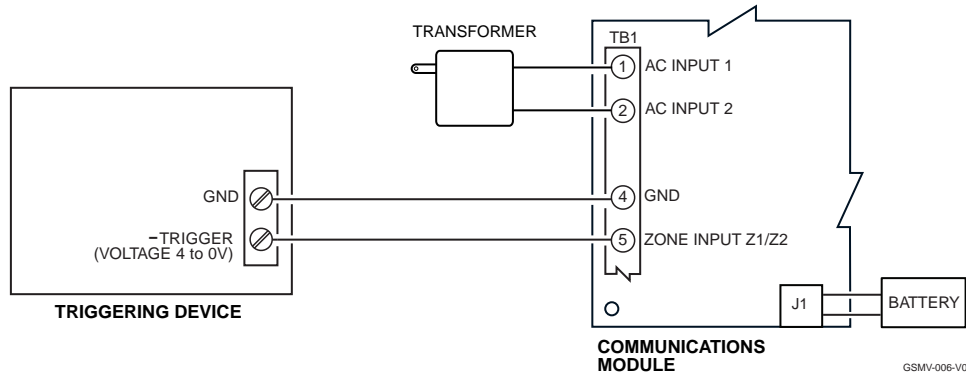

Wiring the Zone 1 Input for a Ground (-V) Trigger

UL

- Zones should use EOL resistors, and be programmed as V+ Inverted or V- Inverted operation such that a cut line results in an alarm.
- Do not use zones 1 and 2 for UL installations.

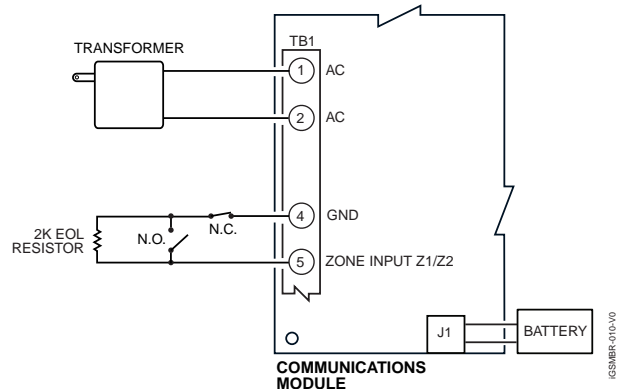

Wiring the Zone 1 Input for EOL Supervised N.O./N.C. Triggers

Wiring the Fault Relay

You may wire and program the communicator's fault output trigger for fail-safe mode (see the question "FLT REL ON Y/N").

To sense a communicator fault at the control panel, see the figure below and make the following connections. Include the proper EOL resistor required by the control panel.

UL / ULC For Commercial Burglary, a 24 hour zone (supervisory) must be assigned on the control panel, with the communicator's fault relay wired to that zone.

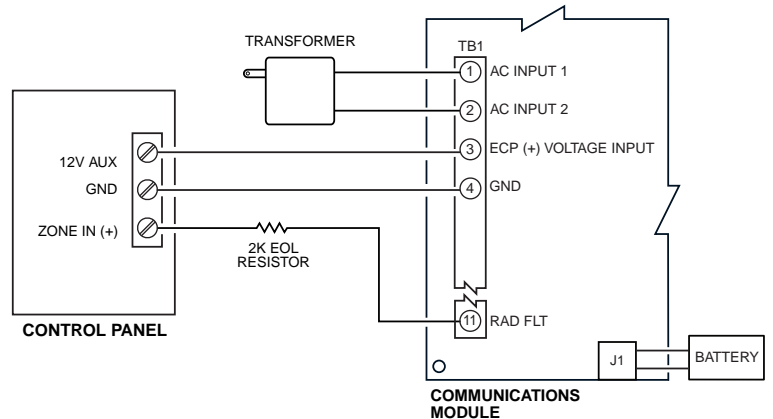

Wiring the Fault Relay to a Control Panel Zone for Normally Closed Fault

Internet Connection

UL

- For UL installations, the Ethernet connection between the communicator and the router cannot exceed 12 feet with both the communicator and the router located within the same room.
- Use a Listed cable/DSL router suited for the application.

Connect one end of the Ethernet cable to the communicator's RJ45 connector and the other end to the cable/DSL router as shown in the figure below.

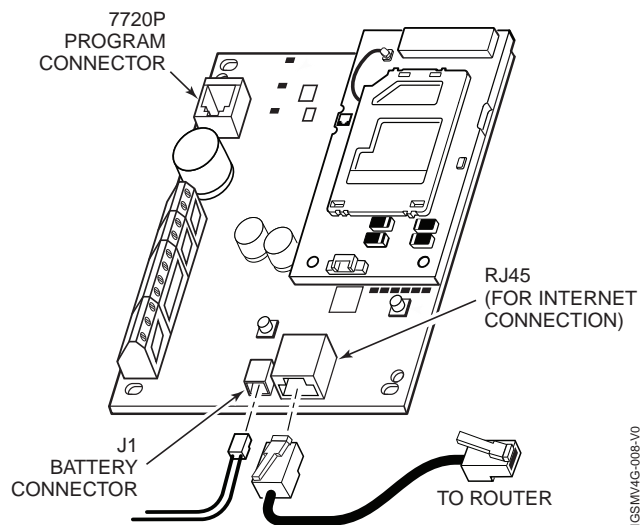

Internet Connection

Power Connections and Options

Powering the Communicator

There are three ways to power the communicator (see illustrations below):

Standard Installation – The communicator is powered by the supplied AC plug-in transformer.

ULC Commercial Fire and Burglary Compliant Installation – The communicator must be powered by the control panel.

Shared Transformer Installation – In this installation the supplied AC plug-in transformer may be used to power both the communicator and the control panel under the following conditions:

- You must use the Honeywell 1361 Transformer.
- This configuration **ONLY** applies to the VISTA-10P, VISTA-15P, VISTA-20P control panels when used with the GSMV4G or IGSMV4G Communicator.
- **DO NOT** use this configuration with any other control panel.
- **DO NOT** use this configuration if using two-way voice.
- This configuration has not been evaluated by UL.

For all installations the control panel ground (GND) must be connected to TB1-4 GND on the communicator. In addition, if using ECP communication, you must connect the +12VDC AUX voltage output on the control panel (9.6V-13.8V typical) to TB1-3 on the communicator.

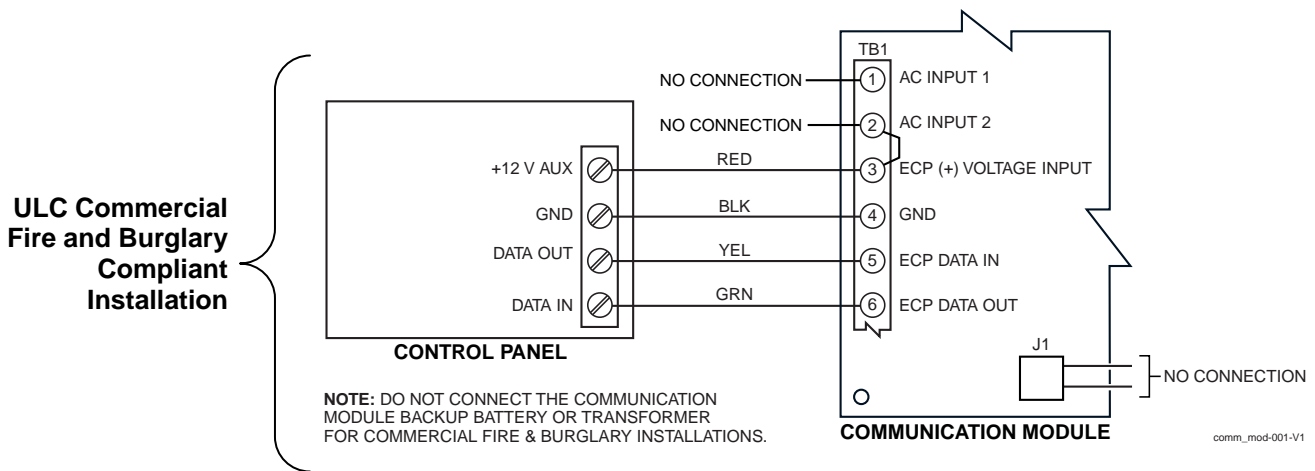
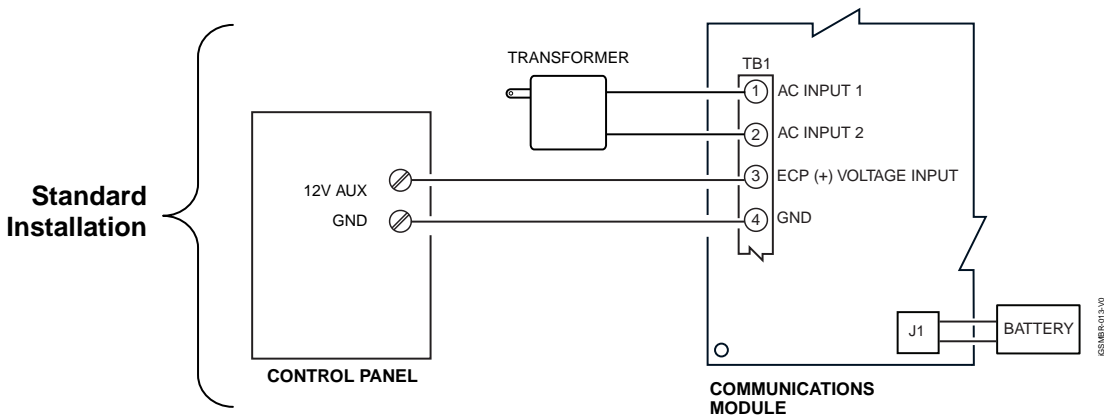

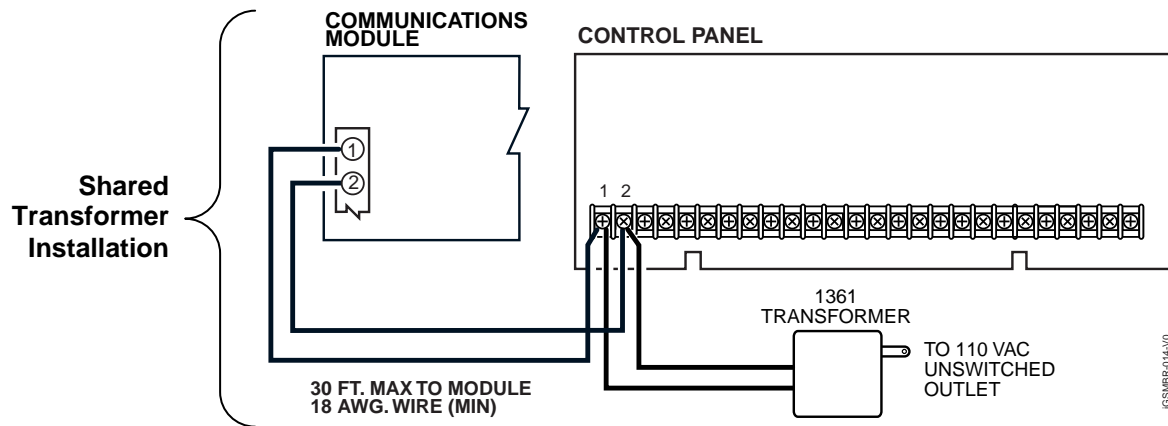

NOTE: When calculating the total load on the auxiliary power output of the control panel, budget 10mA for the communicator when using ECP mode.

Backup Battery Connection

The included battery (K14139) is used for backup in the event of power loss to the communicator. It does not provide power to the control panel.

In ULC installations this battery is not connected, and all backup power is supplied by the control panel.

- The battery can provide over 24 hours of system life in the event of a power failure.
- A programmable power loss message can alert the AlarmNet Control Center when system power is lost (power loss messages are reported within 1-3 hours of actual loss).
- The communicator transmits a low-battery message (programmable) when the battery reaches $5.7V \pm 5\%$, indicating subsequent messages may not be transmitted.
- The system shuts down when the battery falls below 5.1V, and radio transmissions are no longer possible.
- If system power is restored before the communicator shuts down, a power restore message is sent within 1-3 hours after power is restored, and the battery is recharged using the communicator's built-in battery charger. If system power is restored after the communicator has shut down, a power-on reset condition exists, the communicator initializes itself and the battery will recharge.

Install the battery as follows, and refer to the *Summary of Connections* diagram at the end of this document.

1. Place the battery inside the case back.
2. Snap the right side of the battery clip onto the inside of the case back and secure the left side with the screw provided.



Do not plug the battery in until after you have powered-up the communicator.

Initial Power-Up Sequence

Before connecting power, check that the following have been completed:

- If using ECP, 4204 or 2-4204 Mode, terminal block TB1 V+ and GND terminals are connected to the control panel's auxiliary power output: 12VDC nominal.
- Plug in the transformer. Then connect the red and black battery cables to the battery terminals. Connect battery cable to connector J1.
- Power up the control panel. (Initially, all communicator programming options are set to the factory default settings.)

Programming the Communicator

General Information

The communicator delivers alarms via the Internet to an AlarmNet central station or via the AlarmNet-G network, using GSM (Global System for Mobile) technology when the Internet is not available.

The communicator uses 256 bit AES (Rijndael) encryption which is required for certain government installations.



The communicator requires an AlarmNet-I account. For new installations, please obtain the account information from the central station prior to programming this communicator. For replacement installations, the AlarmNet-i account is created automatically when the communicator is registered.

You can program a communicator by one of the following methods:

- Through the AlarmNet Direct website (required to enable Multi-Mode features)
- Through use of a 7720P Programming Tool
- Through a programming mode in the control panel, on panels that support this option (e.g., VISTA-128BP and FBP)

UL Only ECP and Zone Trigger modes have been evaluated by UL.

Using the AlarmNet Direct Website

To program the communicator via the website (if you are already signed up for this service), go to: <https://services.alarmnet.com/AlarmNetDirect/userlogin.aspx>

If you are not signed up for this service, click on “Dealer Sign-Up.”

Log in and follow the on-screen prompts.

Please have the following information available when programming the communicator:

1. Primary City ID (two-digit number)
2. Primary Central Station ID (two-digit hexadecimal number)
3. Primary Subscriber ID (four-digit number)
4. MAC ID and MAC CRC number (located on the box and inside the communicator)

After programming is complete, you must transfer the data to the communicator and the communicator must be registered. Refer to *Section 4: Registration*, for further instructions.

Using a 7720P Programming Tool

Connect the 7720P Programming Tool as shown below. The communicator powers the 7720P Programming Tool via the programming jack, and automatically senses the presence of the 7720P when it is plugged in.

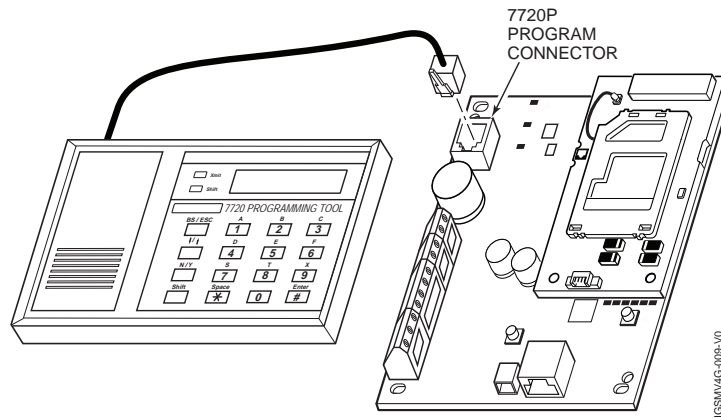

7720P Programmer Tool Connection

Each key of the 7720P has two possible functions: a normal function and a Shift function. To perform a normal key function, simply press the desired key. To perform a Shift function, press the [shift] key, and then press the appropriate key. The prompts in this document reflect use of the 7720P Programming Tool. The table below lists each normal and shift key function.

Table 3-1. 7720P Normal and Shift Key (shift LED lit) Functions

KEY	NORMAL KEY FUNCTION	SHIFT KEY FUNCTION
BS/ESC	[BS]: Press to delete entry	[ESC]: Press to quit program mode; also can reset programming defaults*
↓/↑	[↓]: Scroll down programming	[↑]: Scroll up programming
N/Y	[N]: Press for "NO" answer	[Y]: Press SHIFT-Y for "YES" answer
SHIFT	Press before pressing a SHIFT key function. Will light SHIFT LED. LED goes out once a key is pressed. Press again for each SHIFT function desired.	
1/A	[1]: For entering the number 1	[A]: For entering letter A
2/B	[2]: For entering the number 2	[B]: For entering letter B
3/C	[3]: For entering the number 3	[C]: For entering letter C
4/D	[4]: For entering the number 4	[D]: For entering letter D
5/E	[5]: For entering the number 5	[E]: For entering letter E
6/F	[6]: For entering the number 6	[F]: For entering letter F
7/S	[7]: For entering the number 7	[S]: For entering letter S
8/T	[8]: For entering the number 8	[T]: For entering letter T
9/X	[9]: For entering the number 9	[X]: For entering letter X
SPACE	[SPACE]: For scrolling option list	No SHIFT function
0	[0]: For entering the number 0	No SHIFT function
#/ENTER	[#/ENTER]: Starts programming mode; Press to accept entries	No SHIFT function

* Active only when the "Exit Programming Mode" prompt is displayed.

Using the Control Panel Programming Mode

Some control panels support programming of the communicator through the control panel programming mode (e.g., VISTA-128BP). If programming through the control panel, only the ECP Mode programming options are available. The "mode" questions will not be displayed, and the mode cannot be changed. For a description of key functions on the control panel keypad, and how they map to the 7720P Programming tool, refer to the control panel's Programming Guide.

Programming Conventions

Programming is accomplished by answering a series of prompts (questions). Most prompts require only a [Y]es or [N]o response, while others require a numerical response (ID numbers, etc.).

The current value is displayed on the second line in parentheses (.). A "?" indicates an invalid entry.

Use the [ENTER] key to accept the current entry and proceed to the next prompt. If the entered value is invalid, pressing [ENTER] re-displays the prompt; the next prompt is not displayed until a valid answer is entered.

Use the up/down arrow keys to scroll through the programming questions without changing any values. Press the [ESC] key to go to the end of the list of questions.

ECP Mode Programming

The communicator supports ECP messaging to communicate with the control panel. Likewise the control panel sends Contact ID format alarms to the communicator via the ECP bus. Not all control panels support the communicator interface on ECP, so be sure to check the Installation and Setup Guide of the control panel to see if it supports this feature.

ULC Only ECP Mode has been approved for ULC installations.

Refer to *Table 3-2* for ECP Mode programming and follow the prompts.

Press the [ENTER] key to begin programming.

NOTE: The central station can remotely block access to local device programming. If this has been done, the following prompt appears:

Access to Prog Mode Denied

NOTE: The default programming values for ECP mode are listed in each prompt below.

Table 3-2: Programming the Communicator for ECP mode only.

PROMPTS	OPTIONS	DESCRIPTION
1 Strt Prog Mode? (Y/N)_	[Y], [N]	Enters programming mode.
2 Enter Password:	[0-9, A-F, N, S, T, X, Y]	If a password has been previously assigned, this prompt appears. Enter a 4-digit password (0-9, A-F, N, S, T, X, Y). The next prompt appears.
3 Program Device? (Y/N)_	[Y], [N]	To begin programming the communicator, press [Y] and go to Prompt 9: "Device Mode." To create a password if none has been assigned, press [N] and go to Prompt 4: "Create Password." To change an existing password, press [N] and go to Prompt 5: "Change Password."
4 Create Password? (Y/N)_	[Y], [N]	Passwords can be used to protect account and programming information. If no password has been assigned, this prompt appears after pressing [N] at the "Program Device?" prompt. If a password is desired, press [Y] and go to "Enter Password."
5 Change Password? (Y/N)_	[Y], [N]	If a password has already been assigned, this prompt appears after pressing [N] at the "Program Device?" prompt. Press [Y] if you want to change the password. NOTE: To clear an existing password, without entering a new one, answer [Y] to the "Change Password?" prompt, then press the [Enter] key when prompted for the new password and its confirmation.
6 Enter Password	[0-9, A-F, N, S, T, X, Y]	This prompt is displayed if [Y] was pressed in Prompt 4 or 5. Enter a 4-digit password (0-9, A-F, N, S, T, X, Y).

	PROMPTS	OPTIONS	DESCRIPTION
7	Verify Password	[0-9, A-F, N, S, T, X, Y]	Re-enter the password as confirmation. If the password doesn't match the first entry, the following is displayed followed by the "Exit Prog. Mode?" prompt: Verify Not OK PSWD not created Otherwise, the "Exit Prog. Mode?" prompt is displayed directly.
8	Exit Prog. Mode? (Y/N)_	[Y], [N] [ESC]	Exits program mode. Press [N] to go back to Prompt 3. Press [ESC] to load factory defaults. Refer to the <i>Exiting Programming Mode</i> paragraph in this section.
9	Device Mode (ECP)_	<ul style="list-style-type: none"> ECP Zone Triggers 4204 Emu Two 4204s 	Press [ENTER] to select ECP mode. Press the [space] key to scroll through choices. IMPORTANT , if either Zone Trig, 4204 Emu, or Two 4204s device mode is desired, use <i>Table 3-4</i> for programming.
<p>Important Information Regarding Multi-Mode Options</p> <p>NOTE: In order for the <u>Multi Mode</u>, <u>Remote Access</u>, and <u>Keypad Address</u> programming fields to appear an account must be created in the AlarmNet Direct website and "Remote Access" must be enabled for the comm device. Users can receive email notification of system events by using the Multi-Mode feature. In ECP mode, this is accomplished through emulation of a 4204 relay module, or two 4204 relay modules.</p> <ul style="list-style-type: none"> When "4204-sourced" is selected, the user can be notified of up to four events, plus two additional events if using the optional communication device zones of 6 and 7. When "2-4204-sourced" is selected, the user can be notified of up to eight events. The Multi-Mode address must match the address of a relay module enabled in the control panel (although you don't actually connect a module). If using "2-4204-sourced," the address of the second module is automatically assigned the next device address after the first 4204. When "Enhanced Reports" is selected, a device address of 25 should be selected. <p>Make sure the addresses are also enabled in the control panel. Program outputs to trigger on system events the user would like to be notified of through Output Device (Relay) programming in the control panel. These events are configured at the AlarmNet Total Connect website at: https://services.alarmnet.com/TotalConnect</p>			
 <p>Multi-Mode (email notification) is intended as a convenience for the user, and does not replace Central Station reporting of critical events (alarms, troubles, etc.).</p>			
<p>UL/ULC Multi-Mode has not been evaluated by UL or ULC.</p>			
10	Multi Mode (Disabled)_	<ul style="list-style-type: none"> Disabled 4204 Sourced 2-4204 Sourced Enhanced Reports 	Enable if you want system events sent by email to the user. Select "4204 Sourced" to send up to four events (plus two additional reports triggered by optional hardwire zones 6 and 7), or "2-4204 Sourced" to send eight events. Disable for normal alarm processing and go to Prompt 12: "Primary City ID". Select "Enhanced Reports" to enable reporting to TC2 web services. Note, to use "Enhanced Reports" ensure the control panel is <u>Total Connect 2.0 Ready</u> .
11	Multi Mode Addr (12)_	[01-30]	This address must be programmed if using the Multi- Mode (email notification) feature. The device address must be unique from the normal communicator (or LRR) device address, and the Keypad Address used for Remote Access or Direct Wire downloading. The address used must also be enabled as a 4204 relay module in Vista and First Alert control panels. See Important Information above.
<p>Important Information Regarding Primary and Secondary Accounts (Questions 12-18)</p> <p>Account information is provided by the central station administrator. If the control panel supports secondary account reporting, you will need secondary account information. The City ID, CS ID or Subscriber ID of the secondary account must differ from that of the primary account.</p>			

	PROMPTS	OPTIONS	DESCRIPTION
12	Primary City ID (??)_	[01-99]	Enter the 2-digit primary city ID, 01-99 (decimal).
13	Primary CS ID (??)	[01-FE]	Enter the 2-digit primary central station ID number, 01-FE (HEX).
14	Primary Sub ID (????)	[0001-9999]	Enter the 4-digit subscriber account number, 0001-9999 (decimal).
15	En. 2nd CS Y/N (N)_	[Y], [N]	Applicable only if the control panel supports Central Station #1 and #2 Category Enable reporting for the communicator device (e.g., VISTA-128BP, FA1660C). Used if reporting to a second central station is desired. If [N], go to Prompt 19: "Device Address."
16	2nd City ID (??)_	[01-99]	Enter the 2-digit secondary city ID, 01-99 (decimal).
17	2nd CS ID (??)_	[01-FE]	Enter the 2-digit second central station's ID number, 01-FE (HEX).
18	2nd Sub ID (????)_	[0001-9999]	Enter the 4-digit subscriber account number for the second central station, 0001-9999.
19	Device Address (03)_	[01-30]	In ECP mode, the IGSMV4G communicates with the control panel using the ECP bus. Enter the appropriate ECP device address. For VISTA-10 and VISTA-20 series control panels, use address 03. For other control panels, see their Installation and Setup Guide. NOTES: 1. When programming the control panel, enable the communicator (or LRR) output. 2. The device address must be unique from the "Keypad Address" entered in Prompt 22, and the "Multi-Mode Address" entered in Prompt 11.
UL / ULC Remote access has not been evaluated by UL or ULC.			
20	RemoteAccess Y/N (N)_	[Y], [N]	Press [Y] to allow the end user to access their system via a website. Availability of this service is controlled by the dealer via the web-based programming tool on the AlarmNet Direct website.
21	Direct Wire Y/N (N)_	[Y], [N]	Applies only to VISTA-128BP/250BP and FBP Series control panels, and FA1660C and 1700C Series control panels. Enables Direct Wire Downloading over IP. If [N], and if Prompt 20: "Remote Access" is disabled, skip to Prompt 23: "Supervision."
22	Keypad Address (28)_	[01-30]	Must be programmed if using either the Remote Access feature or Direct Wire downloading. NOTES: 1. This address must also be programmed as an alpha keypad in the control panel or an AUI (advanced user interface) type device, if a full enhanced graphic interface to the system is desired and the control panel supports it. DO NOT connect an actual keypad (or any other device) assigned to this address. 2. This address must be unique from the "Device Address" entered in Prompt 19.

	PROMPTS	OPTIONS	DESCRIPTION
23	Supervision (24 Hours)_	<ul style="list-style-type: none"> • 30 Day • 24 Hrs • None Additional options for CN only <ul style="list-style-type: none"> • 1 Hr • CN UL Line Lvl 3 (3 Min) • CN UL Line Lvl 4 (90 Sec) • CN UL Line Lvl 5 (75 Sec) 	The AlarmNet network must hear at least one supervisory message from the communicator during this supervision period; otherwise, AlarmNet notifies the central station that a communication failure has occurred. (If the supervision period is changed after registration, you must re-register the communicator.) Press the [space] key to scroll through choices. UL: A loss of communications is treated as an Alarm condition. ULC: Must be set to "CN UL Line Lvl 3" for ULC-S304 Active Level 3 or ULC-S559 Active Fire installations. All other commercial applications must be set to "24 Hrs".
24	GSM Rollover Y/N (N)_	[Y] , [N]	If enabled, all messages (including AlarmNet network supervisory messages) are sent over the GSM network in the event of an Internet failure. If disabled, all messages (except AlarmNet network supervisory messages) are sent automatically over the GSM network in the event of an Internet failure. UL/ULC: Must be set to "Y" if 24 hours is selected in Prompt: 23: Supervision. Must be set to "N" for ULC-S304 Active Level 3 or ULC-S559 Active Fire installations where CN UL Line Lvl 3 is selected. IMPORTANT WARNING: If set to "Y", AND Prompt 23: Supervision is set to occur less than every 24 hours, this can result in data overage charges on your monthly bill.
25	GSM 24Hr Tst Y/N (N)_	[Y], [N]	If enabled a message is sent every 24 hrs over GSM to verify proper operation. If it fails, a Periodic Comm Test Failure message will be sent over Ethernet. UL/ULC: Must be set to "Y".
26	Old Alarm Time 10 Minutes_	<ul style="list-style-type: none"> • 10 Minutes • 4 Hours • 15 Minutes • 8 Hours • 30 Minutes • 12 Hours • 1 Hour • 24 Hours • 2 Hours • 4 Hours • 8 Hours • 12 Hours • 24 Hours 	Sets how long an undeliverable alarm is retried for delivery to the central station. If the message is not validated, it is retried until the old alarm time is reached or the message is validated. Press the [space] key to scroll through choices. UL/ULC: Must be 10 minutes.
27	IP Fit Time (60 mins)_	[00-99]	In the event there is a loss of contact with the network over the Ethernet connection, enter the time delay (in minutes) before the communicator notifies the central station. IP failure will always be sent to the central station as Primary Communication Path Failure. UL/ULC: Must be one (01) minute.
28	GSM Fit Time (60 mins)_	[00-99]	In the event the communicator detects a communication path failure, enter the time delay (in minutes) before the communicator notifies the central station. A GSM failure will always be sent to the central station as Secondary Communication Path Failure. UL/ULC: Must be one (01) minute.
29	Notify Panel Of (Neither Fault)	[Neither fault] [Both IP and GSM Faults]	If "Both IP and GSM Fault" is selected, the device will only notify the control panel if both communication paths fail, but will always send notification of either failure to the central station. NOTE: The fault relay output (if programmed) will be triggered only if "Both IP and GSM Faults" is selected. (If the "GSM Fault Time" and "IP Fault Time" options are set to

	PROMPTS	OPTIONS	DESCRIPTION
			zero, faults will not be reported.) Press the [space] key to scroll through choices. UL/ULC: Must be set to "Both IP and GSM Faults".
30	Fit Rel ON Y/N (N)_	[Y], [N]	If enabled, the fault open collector output is normally energized to ground, and de-energizes (open circuit) in the event of a communicator fault. For conditions that trip the fault relay refer to <i>Supervision Features</i> in Section 1. Set to [Y] if fail-safe mode is desired. See <i>Wiring the Fault Relay</i> in Section 2. UL/ULC: Must be set to "Y."
31	Pwr Loss Rpt Y/N (Y)_	[Y], [N]	Sends a primary power loss report to the central station within 1-3 hours after its detection. A restore report is sent within 1-3 hours after power is restored. UL/ULC Standard Installations (using transformer and battery): Must be set to "Y". ULC Commercial Fire & Burglary Installations (powered from the control panel): Must be set to "N."
32	Low Bat Rpt Y/N (Y)_	[Y], [N]	Sends a low-battery report when a low battery condition exists. A low battery restore is automatically sent when the low battery condition clears. UL/ULC Standard Installations (using transformer and battery): Must be set to "Y". ULC Commercial Fire & Burglary Installations (powered from the control panel): Must be set to "N."
33	Tamper Rpt Y/N (Y)_	[Y], [N]	Sends a tamper report when the communicator detects a tamper condition. A tamper restore is automatically sent when the tamper condition clears. UL/ULC: Must be set to "Y."
Important Information Regarding Zone Input Options			
<p>ECP mode supports two optional hardwire zone input triggers by making connections to the communicator's zone 6 and/or zone 7 terminals and programming the appropriate zone trigger options below.</p> <p>Each zone input can be programmed to cause an alarm under one of the following conditions:</p> <ul style="list-style-type: none"> • (V+), where a positive voltage causes an alarm for normally low connections (voltage trigger, NO, NC) • (V-), where a ground trigger causes an alarm for normally high connections (open collector, NO, NC) • (EOLR) End of Line Resistor, where the input is supervised by a 2K EOL resistor. The zone can be triggered by open collector, voltage trigger, NO, NC. <p><u>UL: Set V+ to inverted, and V- as non-inverted.</u></p> <p>In addition to the above, zones can be programmed for an Inverted Trigger, where the alarm and normal states of the zones are inverted; this can serve a fail-safe supervisory purpose for certain installations. These zone inputs can also be programmed for restore reporting, and for delayed reporting (NOT for UL installations), which allows time for the user to abort false alarms.</p> <p><u>NOTE: Optional hardwire zones report in ADEMCO High-Speed format.</u></p>			
34	Enable Zn6 Y/N (N)_	[Y], [N]	Enables alarm reporting for zone 6. If [N], skip to Prompt 39: "Enable Zn7."
35	Zn6 Trigger Type (V+)_	<ul style="list-style-type: none"> • (V+) • (V-) • (EOLR) 	Selects the triggering method for this zone input. Press the [space] key to scroll through choices. UL: V+ must be set as inverted and V- as non-inverted.
36	Invert Zn6 Y/N (N)_	[Y], [N]	Inverts the alarm and normal states of the zone 6 trigger; otherwise uses normal input signal.
37	Restore Zn6 Y/N (Y)_	[Y], [N]	Enables restore reporting for zone 6.

	PROMPTS	OPTIONS	DESCRIPTION
38	Delay Zn6 (secs) (00)_	[01-15] [00] = no delay	Defines the reporting delay in seconds for zone 6. UL: Must be set to 00.
39	Enable Zn7 Y/N (N)_	[Y], [N]	Enables alarm reporting for zone 7. If [N], skip to Prompt 44: "Use DHCP."
40	Zn7 Trigger Type (V+)_	<ul style="list-style-type: none"> • (V+) • (V-) • (EOLR) 	Selects the triggering method for this zone input. Press the [space] key to scroll choices. UL: V+ must be set as inverted and V- as non-inverted.
41	Invert Zn7 Y/N (N)_	[Y], [N]	Inverts the alarm and normal states of the zone 7 trigger; otherwise, uses normal input signal.
42	Restore Zn7 Y/N (Y)_	[Y], [N]	Enables restore reporting for zone 7.
43	Delay Zn7 (secs) (00)_	[01-15] [00] = no delay	Defines the reporting delay in seconds for zone 7. UL: Must be set to 00.
44	Use DHCP Y/N (Y)_	[Y], [N]	Dynamically allocates the IP addresses (recommended); then skip to Prompt 49: "Enable Pwr Save". If [N], uses fixed IP addresses.
45	NIC IP Address: 255.255.255.255_	12 digit: xxx.xxx.xxx.xxx	Enter the 4-part address for this device. The 4 parts of the address must be separated by spaces (displayed as periods in Review mode).
46	Subnet Mask: 255.255.255.255_	12 digit: xxx.xxx.xxx.xxx	Enter the 32-bit address mask used to indicate the portion (bits) of the IP address that is being used for the subnet address. The 4 parts of the address must be separated by spaces (displayed as periods in Review mode).
47	Gateway IP Addr: 255.255.255.255_	12 digit: xxx.xxx.xxx.xxx	Enter the 4-part address assigned to the Gateway. The 4 parts of the address must be separated by spaces (displayed as periods in Review mode).
48	DNS Serv IP Addr: 255.255.255.255_	12 digit: xxx.xxx.xxx.xxx	Enter the 4-part IP address assigned to the DNS (Domain Name System) server. The 4 parts of the address must be separated by spaces (displayed as periods in Review mode).
49	Enable Pwr Save (N)_	[Y], [N]	To meet the 24 hour UL battery backup requirement, choose "Y" to enable this feature. If this causes connectivity problems with certain routers or switches, then choose "N" and wire the communicator so it is plugged into a UL listed UPS. UL: Must be set to Y.
50	IP Connection (Present)	<ul style="list-style-type: none"> • Present • Auto Detect 	<p>Press the [space] key to toggle between the options. Press [ENTER] to select the configuration.</p> <p>If "Present" is chosen, it is assumed that an IP is connected to the device. If it is not detected, a Primary Comm Path Failure message will be delivered after the programmed fault time expires.</p> <p>If "Auto Detect" is chosen, the device will always try to use IP to communicate but it will not generate a Primary Comm Path Failure unless it previously detected the presence of IP. As soon as the presence of IP is detected, a Primary Comm Path Restore message is generated and the value of IP Connectivity programming parameter is changed from "Auto Detect" to "Detected".</p> <p>From this point on, the software expects connectivity. The auto detect logic will resume only when the parameter is changed back to "Auto Detect".</p>

	PROMPTS	OPTIONS	DESCRIPTION
51	Review? Y/N	[Y] = review [N] = exit	<p>Reviewing Programming Mode Entries</p> <p>To review the programming options (to ensure that the correct entries have been made), press [Y]. The programming prompts are displayed again. Use the up/down arrow keys to scroll through the program fields without changing any of the values. If a value requires change, simply type in the correct value. When the last field is displayed, the "REVIEW?" prompt again appears.</p> <p>To exit the programming mode, press [N] in response to the "REVIEW?" prompt, and refer to <i>Exiting Programming Mode</i> at the end of this section.</p>

ECP Status Codes

When the communicator is configured for ECP mode, it sends status messages to the control panels for battery, power, tamper, and network connectivity failures. Some of the control panels (e.g., VISTA-10P, VISTA-15P and VISTA-20P Series) display these on the keypad as "LngRng Radio" followed by a 4-digit code (listed in the table below). In addition, the Contact ID codes (listed in Appendix B) for these conditions are sent to the central station by the communicator.

UL The information in the following table is based on the VISTA-20 which has not been evaluated with this communicator.

Table 3-3. Common ECP Keypad Display Status Codes

STATUS CODE	DESCRIPTION
0000	Control panel lost communication with communicator.
0880	Communicator tamper detected (cover removed).
4005	Communicator has lost contact with AlarmNet.
000F	Communicator is not registered; account not activated.
0019	Communicator shutdown.
0400	Communicator power on / reset AND the control panel lost communications with communicator.
0C80	Communicator power on / reset AND tamper detected.
0C8F	Communicator power on/ reset AND tamper detected AND not registered.
08E0	Communicator tamper detected and communicator battery low.
3000	Primary power loss (will only be displayed in conjunction with another event).
8000	Battery charger failure (will only be displayed in conjunction with another event).
0060	Low battery (will only be displayed in conjunction with another event).

Alternative Modes (Zone Trigger, 4204 and Two-4204)

UL/ULC The LYNX controls have not been evaluated with this communicator.

Zone Trigger Mode

There are six input zones available on the communicator. Each zone is selectable for +V, -V, or EOLR trigger. The first zone input can detect both pulsed and steady signals if connected to a bell output. Additionally, the first zone input can be programmed to detect a single pulse (characteristic of a Panic indication on the Lynx, LynxR or LynxR-EN control by enabling the Lynx Panic option). If the programming option "Lynx Panic" is enabled, the communicator reports an alarm on zone 3. No restores are reported for this zone. If this option is selected, the second physical zone input is ignored.

When using Zone Trigger mode, messages are sent in ADEMCO High-Speed format. Zones 3, 4, 5, 6 and 7 are voltage trigger inputs located on TB1 pins 6-10. If the Lynx Panic feature is being used, do not connect zone 3 (the second physical zone input). Refer to Table 3-4 for Zone Trigger Mode programming and follow the prompts that pertain to Zone Trigger Mode. A check mark (✓) indicates whether the prompt applies to that mode.

4204 Emulation Mode

In 4204 Emulation Mode, the IGSMV4G communicates with a compatible Honeywell VISTA series or First Alert control panel as though it were a 4204 Relay Module. If two 4204s are enabled in the communicator, it acts as two 4204s at consecutive device addresses. The control panel must be configured to recognize one or two 4204 relay modules accordingly. On VISTA-32FB (or higher) control panels and First Alert equivalents, addresses 6 and 13 should not be used when the secondary 4204 is enabled. Messages are sent in ADEMCO High-Speed format.

NOTE: See your control panel Installation and Setup Guide for the number of 4204 modules supported.

4204 Emulation Mode Options

For control panels that do not support ECP communication, the 4204 Emulation modes provide a means of sending up to eight unique reports based on defined system conditions. In 4204 mode, the communicator functions as a logical 4204 Relay Module, where each relay number, referred to in the communicator as zone number, can be programmed to send a report based on the output function programmed in the control panel for that relay. Each relay-zone can be programmed to; send a restore message of the reported condition, delay the transmission of messages, and to send reports only when a conditional zone is triggered (armed). See *"Important Information Regarding Zone Input Options"* later in this section. In single 4204 mode, the communicator supports up to four relay-zones. In Two-4204 mode, the communicator functions as two 4204 modules, supporting up to eight relay-zones.

UL 4204 Mode and Two-4204 Mode has not been evaluated.

4204 Relay Outputs map to communicator zones as follows:

First 4204 Zones (device address entered in Prompt 14):	Second 4204 Zones (device address entered in Prompt 14, plus 1):
Relay 1 = Zone 1 Relay 2 = Zone 2 Relay 3 = Zone 3 Relay 4 = Zone 4 or conditional zone trigger if "report only if armed" is selected in any zone 1-3 when using single 4204 mode. NOTE: Zone 4 status is not reported when being used as the conditional (armed) trigger zone.	Relay 1 = Zone 5 Relay 2 = Zone 6 Relay 3 = Zone 7 Relay 4 = Zone 8 or conditional zone trigger if "report only if armed" is selected in any zone 1-7 when using Two-4204 mode. NOTE: Zone 8 status is not reported when being used as the conditional (armed) trigger zone or if tamper reporting is enabled.

When using the communicator in 4204 Emulation Mode, DO NOT enable the communicator (or LRR) in the control panel programming. Instead, enable 4204 relay module address(es) and program the appropriate relay activation functions for the relay-zones being used. In some control panels, it is called "relay programming" and in others it is called "output device programming." It is recommended that "close and stay closed" (usually choice 2) action is selected. Selection of momentary activation will cause the communicator to generate an alarm and NOT a restore, even if the communicator is programmed to send a restore for the given zone.

In 4204 mode, messages are reported in ADEMCO High-Speed format. Zone alarms (status 7) are reported with “1” (alarm) or “3” (restore) displayed in the zone position for the respective zone (e.g. alarm on zone 2: 5155 5555 7; restore 5355 5555 7). A supervision fault trouble message is automatically sent if the communicator detects no activity on its connection to the control panel. The message is: 5555 5515 5; restore message is: 5555 5535 5. Refer to Table 3-4 for 4204 Emulation Mode programming and follow the prompts that pertain to 4204 or Two-4204 mode. A check mark (✓) indicates whether the prompt applies to that mode.

Alternative Mode Programming

Press the [ENTER] key to begin programming and follow the prompts for the mode of operation being programmed.

NOTE: The central station can remotely block access to local device programming. If this has been done, the following prompt appears:

Access to Prog Mode Denied

Table 3-4: Programming for Zone Trigger, 4204 Emulation, or Two-4204 Emulation modes.

	PROMPTS	ZONE TRIG.	4204/ 2-4204	OPTIONS	DESCRIPTION
1	Strt Prog Mode? Y/N_	✓	✓	[Y], [N]	Enters programming mode.
2	Enter Password	✓	✓	[0-9, A-F, N, S, T, X, Y]	If a password has been previously assigned, this prompt appears. Enter a 4-digit password (0-9, A-F, N, S, T, X, Y). The next prompt appears.
3	Program Device? Y/N_	✓	✓	[Y], [N]	To begin programming the communicator, press [Y] and go to Prompt 9: "Device Mode." To create a password if none has been assigned, press [N] and go to Prompt 4: Create Password. To change an existing password, press [N] and go to Prompt 5: "Change Password."
4	Create Password? Y/N_	✓	✓	[Y], [N]	Passwords can be used to protect account and programming information. If no password has been assigned, this prompt appears after pressing [N] at the "Program Device?" prompt. If a password is desired, press [Y] and go to Prompt 6: "Enter Password."
5	Change Password? Y/N_	✓	✓	[Y], [N]	If a password has already been assigned, this prompt appears after pressing [N] at the "Program Device?" prompt. Press [Y] if you want to change the password. NOTE: To clear an existing password, without entering a new one, answer [Y] to the "Change Password?" prompt, then press the [Enter] key when prompted for the new password and its confirmation.
6	Enter Password	✓	✓	[0-9, A-F, N, S, T, X, Y]	This prompt is displayed if [Y] was pressed in Prompt 4 or 5. Enter a 4-digit password (0-9, A-F, N, S, T, X, Y).

	PROMPTS	ZONE TRIG.	4204/ 2-4204	OPTIONS	DESCRIPTION
7	Verify Password	✓	✓	[0-9, A-F, N, S, T, X, Y]	Re-enter the password as confirmation. If the password doesn't match the first entry, the following is displayed followed by the "Exit Prog. Mode?" prompt: Verify Not OK PSWD not created Otherwise, the "Exit Prog. Mode?" prompt is displayed directly.
8	Exit Prog. Mode? Y/N_	✓	✓	[Y], [N] [ESC]	Exits program mode. Press [N] to go back to Prompt 3. Press [ESC] to load factory defaults. Refer to the <i>Exiting Programming Mode</i> paragraph in this section.
9	Device Mode (ECP)_	✓	✓	• ECP • Zone Trig. • 4204 Emu • Two 4204s	Press the [space] key to scroll through the modes of operation. Press [ENTER] to select mode. IMPORTANT , if ECP device mode is desired, use <i>Table 3-2</i> for programming.
Important Information Regarding Multi-Mode					
NOTE: In order for the <u>Multi Mode</u> , <u>Remote Access</u> , and <u>Keypad Address</u> programming fields to appear an account must be created in the AlarmNet Direct website and "Remote Access" must be enabled for the comm device. In Zone Trigger mode, the options for Multi-Mode are "Enabled" or "Disabled." If enabled, whenever a zone on the communication device is triggered, a corresponding email message is sent INSTEAD of normal central station reports. Cover tamper will send email event 8. All communication device system events (such as power loss, low battery, Telco, etc.) are still sent to AlarmNet. Events used to send email messages are defined on the Honeywell Total Connect web site, and must correspond to events triggering the hardwired zones.					
 Multi-Mode (email notification) is intended as a convenience for the user, and does not replace Central Station reporting of critical events (alarms, troubles, etc.).					
UL Multi-Mode has not been evaluated by UL.					
10	Multi Mode (Disabled)_	✓		• Enabled • Disabled	Enable if you want system events sent by email to the user. Disable for normal alarm processing.
Important Information Regarding Primary Account (Questions 11-13)					
Account information is provided by the central station administrator.					
11	Primary City ID (??)_	✓	✓	[01-99]	Enter the 2-digit primary city ID, 01-99 (decimal).
12	Primary CS ID (???)	✓	✓	[01-FE]	Enter the 2-digit primary central station ID number, 01-FE (HEX).
13	Primary Sub ID (????)	✓	✓	[0001-9999]	Enter the 4-digit subscriber account number, 0001-9999 (decimal).
14	Device Address (12)_		✓	[01-15]	The IGSMV4G communicates with the control panel as a 4204 relay module. Enter the appropriate address. For VISTA-10P, and FA130CP Series control panels, this must be address 12. For other controls panels, see their Installation and Setup Guide. NOTES: 1. The 4204 protocol limits address range to 01-15. If using 2-4204 mode, the communicator assigns the second 4204 to the next higher device address (e.g., if entering address 12 for the first 4204, then address 13 is automatically assigned to the second 4204 module). Program the control panel accordingly. 2. The device address(es) must be unique from the

	PROMPTS	ZONE TRIG.	4204/ 2-4204	OPTIONS	DESCRIPTION
					"Keypad Address" entered in Prompt 17 and any other address used on the control panel.
UL / ULC Remote access has not been evaluated by UL or ULC.					
15	RemoteAccess Y/N (N)_		✓	[Y], [N]	Press [Y] to allow the end user to access their system via a website. Availability of this service is controlled by the dealer via the web-based programming tool on the AlarmNet Direct website.
16	Direct Wire Y/N (N)_		✓	[Y], [N]	Applies only to VISTA-128BP/250BP and FBP Series control panels, and FA1660C and 1700C Series control panels. Enables Direct Wire Downloading over IP. If [N], and if Prompt 15: "Remote Access" is disabled, skip to Prompt 18: "Supervision."
17	Keypad Address (28)_		✓	[01-30]	This address must be programmed if using either the Remote Access feature or Direct Wire downloading. Enter the appropriate device address. NOTES: 1. This address must also be programmed as an alpha keypad in the control panel or an AUI (Advanced User Interface) type device, if a full enhanced graphic interface to the system is desired and the control panel supports it. DO NOT connect an actual keypad (or any other device) assigned to this address. 2. This address must be unique from the "Device Address" entered in Prompt 14, and cannot equal that device address plus 1 (one) if using 2-4204 mode.
18	Supervision (24 Hours)_	✓	✓	<ul style="list-style-type: none"> • 30 Day • 24 Hrs • None Additional options for CN only <ul style="list-style-type: none"> • 1 Hr • CN UL Line Lvl 3 (3 Min) • CN UL Line Lvl 4 (90 Sec) • CN UL Line Lvl 5 (75 Sec) 	The AlarmNet network must hear at least one supervisory message from the communicator during this supervision period; otherwise, AlarmNet notifies the central station that a communication failure has occurred. (If the supervision period is changed after registration, you must re-register the communicator.) Press the [space] key to scroll through choices. UL: A loss of communications is treated as an Alarm condition. ULC: Must be set to "CN UL Line Lvl 3" for ULC-S304 Active Level 3 or ULC-S559 Active Fire installations. All other commercial applications must be set to "24 Hrs".
19	GSM Rollover Y/N (N)_	✓	✓	[Y], [N]	If enabled, all messages (including AlarmNet network supervisory messages) are sent over the GSM network in the event of an Internet failure. If disabled, all messages (except AlarmNet network supervisory messages) are sent automatically over the GSM network in the event of an Internet failure. UL/ULC: Must be set to "Y" if 24 hours is selected in Prompt: 18: Supervision. Must be set to "N" for ULC-S304 Active Level 3 or ULC-S559 Active Fire installations where CN UL Line Lvl 3 is selected. IMPORTANT WARNING: If set to "Y", AND Prompt 18: Supervision is set to occur less than every 24 hours, this can result in data overage charges on your monthly bill.

	PROMPTS	ZONE TRIG.	4204/ 2-4204	OPTIONS	DESCRIPTION
20	GSM 24Hr Tst Y/N (N)_	✓	✓	[Y], [N]	If enabled a message is sent every 24 hrs over GSM to verify proper operation. If it fails, a Periodic Comm Test Failure message will be sent over Ethernet. UL/ULC: Must be set to "Y".
21	Old Alarm Time 10 Minutes_	✓	✓	<ul style="list-style-type: none"> • 10 Min • 15 Min • 30 Min • 1 Hr • 2 Hrs • 4 Hrs • 8 Hrs • 12 Hrs • 24 Hrs 	Sets how long an undeliverable alarm is retried for delivery to the central station. If the message is not validated, it is retried until the old alarm time is reached or the message is validated. Press the [space] key to scroll through choices. UL/ULC: Must be set to 10 minutes.
22	IP Flt Time (60 mins)_	✓	✓	[00-99]	In the event there is a loss of contact with the network over the Ethernet connection, enter the time delay (in minutes) before the communicator notifies the central station. IP failure will always be sent to the central station as Primary Communication Path Failure. UL/ULC: Must be one (01) minute.
23	GSM Flt Time (60 mins)_	✓	✓	[00-99]	In the event the communicator detects a communication path failure, enter the time delay (in minutes) before the communicator notifies the central station. A GSM failure will always be sent to the central station as Secondary Communication Path Failure. UL/ULC: Must be one (01) minute.
24	Notify Panel Of_ (Neither Fault)_	✓	✓	[Neither fault] [Both IP and GSM Faults]	If "Both IP and GSM Fault" is selected, the device will only notify the control panel if both communication paths fail, but will always send notification of either failure to the central station. NOTE: The fault relay output (if programmed) will be triggered only if "Both IP and GSM Faults" is selected. (If the "GSM Fault Time" and "IP Fault Time" options are set to zero, faults will not be reported.) Press the [space] key to scroll through choices. UL/ULC: Must be set to "Both IP and GSM Faults".
25	Flt Rel ON Y/N (N)_	✓	✓	[Y], [N]	If enabled, the fault open collector output is normally energized to ground, and de-energizes (open circuit) in the event of a communicator fault. For conditions that trip the fault relay refer to <i>Supervision Features</i> in Section 1. Set to [Y] if fail-safe mode is desired. See <i>Wiring the Fault Relay</i> in Section 2. UL/ULC: Must be set to "Y".
26	Pwr Loss Rpt Y/N (Y)_	✓	✓	[Y], [N]	Sends a primary power loss report to the central station within 1-3 hours after its detection. A restore report is sent within 1-3 hours after power is restored. UL/ULC Standard Installations (using transformer and battery): Must be set to "Y". ULC Commercial Fire & Burglary Installations (powered from the control panel): Must be set to "N."

	PROMPTS	ZONE TRIG.	4204/ 2-4204	OPTIONS	DESCRIPTION
27	Low Bat Rpt Y/N (Y)_	✓	✓	[Y], [N]	Sends a low-battery report when a low battery condition exists. A low-battery restore is automatically sent when the low battery condition clears. UL/ULC Standard Installations (using transformer and battery): Must be set to "Y". ULC Commercial Fire & Burglary Installations (powered from the control panel): Must be set to "N."
28	Tamper Rpt Y/N (Y)_	✓	✓	[Y], [N]	Sends a tamper report when the communicator detects a tamper condition. A tamper restore is automatically sent when the tamper condition clears. UL/ULC: Must be set to "Y".
29	Lynx Panic Y/N (N)_	✓		[Y], [N]	Applies only if used with a Lynx, LynxR or LynxR-EN controls where the communicator (or LRR) trigger is connected to the communicator's zone terminal. Reports a Panic alarm on zone 3 when the communicator detects a single pulse on zone 1. No restores are generated for a Panic alarm. UL/ULC: The LYNX controls have not been evaluated with this communicator.

Important Information Regarding Zone Input Options

If desired, **4204 mode** supports two optional hardwire zone input triggers by making connections to the communicator's zone 6 and/or zone 7 terminals and programming the appropriate zone trigger options below.

NOTE: These triggers are not available when using 2-4204 mode.

Zone Trigger Mode provides six hardwire zone input triggers by making connections to the communicator's zone terminals and programming the appropriate zone trigger options below. Zones are numbered 1-7, with zone 2 serving as a reporting zone only (see Bell Output Zone below).

Bell Output Zone 1 (and 2): The zone 1 terminal can detect both pulsed and steady signals. If connecting the bell output to the communicator zone causes a bell fault on the control panel, enable the "Trip Inputs 1 or 2" option. The communicator reports an alarm on zone 1 (fire) when it detects a pulsed signal and an alarm on zone 2 (burglary) when it detects a steady signal.

UL: Use of the Bell output is not supported.

Telco Zone and Open/Close Zone: Dedicated zones can be assigned as the Telco fault zone and/or an open/close (arm/disarm) reporting zone. When triggered, these zones report a Telco line fault or open/close report respectively, in ADEMCO High-Speed format. Connect the appropriate trigger from the control panel to the selected zone input for each of these options.

Input Trigger Types: Triggering of each zone input can be programmed to cause an alarm under one of the following conditions:

- (V+), where a positive voltage causes an alarm for normally low connections (voltage trigger, NO, NC)
- (V-), where a ground trigger causes an alarm for normally high connections (open collector, NO, NC)
- (EOLR) End of Line Resistor, where the input is supervised by a 2K EOL resistor. The zone can be triggered by open collector, voltage trigger, NO, NC.

UL: Set V+ to inverted, and V- as non-inverted.

Inverted Trigger: Zones can be programmed for inverted trigger, where the alarm and normal states of the zones are inverted; this can serve a fail-safe supervisory purpose for certain installations.

Restore and Delayed Reports: Zone inputs can be programmed for restore reporting, and for delayed reporting (NOT for UL installations) allowing time for the user to abort false alarms.

UL/ULC: Zone restoral must be enabled.

Report Only if Armed option: To help eliminate redundant reports, zone alarms can be restricted to report only if a conditional zone is triggered (armed). If this feature is desired, the conditional zone is automatically used as the "arming" zone. Connect the appropriate control panel trigger to the conditional (arming) zone. The trigger must be programmed as necessary in the control panel.

The conditional (arming) zone on the communicator is a different dedicated zone for each programming mode, as follows:

PROMPTS	ZONE TRIG.	4204/ 2-4204	OPTIONS	DESCRIPTION								
<table border="1" style="margin: auto;"> <tr> <td style="text-align: center;">Mode</td> <td style="text-align: center;">Conditional (Arming) Zone</td> </tr> <tr> <td style="text-align: center;">Zone Trigger</td> <td style="text-align: center;">7</td> </tr> <tr> <td style="text-align: center;">4204</td> <td style="text-align: center;">4</td> </tr> <tr> <td style="text-align: center;">2-4204</td> <td style="text-align: center;">8</td> </tr> </table>					Mode	Conditional (Arming) Zone	Zone Trigger	7	4204	4	2-4204	8
Mode	Conditional (Arming) Zone											
Zone Trigger	7											
4204	4											
2-4204	8											
<p>IMPORTANT: If any zone (zones 1-6 in zone trigger mode, zones 1-3 in 4204 mode, zones 1-7 in 2-4204 mode) is set for Report Only if Armed, the conditional (arming) zone becomes unavailable for reporting (as it is reserved for the "arming" trigger connection).</p>												
30	Trip Inputs 1or2 w/Bell Out (N)_	✓		[Y], [N] Use if the zone 1 connection to the control panel's bell output causes a bell fault at the control panel. NOTES: 1. If used, EOLR trigger type is not available for zones 1 and 3. 2. Do not use with Lynx controls.								
31	Telco Zone (0)_	✓	✓	Zone Trig: [3-7] 4204: [1-4] 2-4204: [1-8] [0] = not used See Important Information Regarding Zone Input Options on previous page. Enter the zone number to be used for Telco line fault reports. This zone assignment must be unique from the open/close zone selected in Prompt 32. Zone Trigger Mode: If any zone is programmed for "report only if armed," zone 7 cannot be used. If Lynx Panic is enabled, zone 3 cannot be used. 4204 Mode: If any zone is programmed for "report only if armed," zone 4 cannot be used. 2-4204 Mode: If any zone is programmed for "report only if armed," or if tamper is enabled, zone 8 cannot be used. NOTE: Connect the Telco line fault output (or relay output programmed for "Telco line fault") to the Telco zone.								
32	Open/Close Zone (0)_	✓	✓	Zone Trig: [3-7] 4204: [1-4] 2-4204: [1-8] [0] = not used Enter the zone number to be used for open/close (arm/disarm) reports. This zone assignment must be unique from the Telco zone selected in Prompt 31. Zone Trigger Mode: If any zone is programmed for "report only if armed," zone 7 cannot be used as an open/close zone. If Lynx Panic is enabled, zone 3 cannot be used. 4204 Mode: If any zone is programmed for "report only if armed," zone 4 cannot be used as an open/close zone. 2-4204 Mode: If any zone is programmed for "report only if armed," or if tamper is enabled, zone 8 cannot be used as an open/close zone. NOTE: Connect an open/close (arm/disarm) trigger (or relay output) from the control panel to the open/close zone.								
33	Zn1 Trigger Type (V+)_	✓		• (V+) • (V-) • (EOLR) Selects the triggering method for this zone input. Press the [space] key to scroll through the choices. UL: V+ must be set as inverted and V- as non-inverted.								
34	Restore Zn1 Y/N (Y)_	✓	✓	[Y], [N] Enables restore reporting for zone 1. UL/ULC: Must be set to "Y."								
35	Delay Zn1 (secs) (00)_	✓	✓	[01-15] [00] = no delay Defines the reporting delay in seconds for zone 1. UL/ULC: Must be set to "00."								

	PROMPTS	ZONE TRIG.	4204/ 2-4204	OPTIONS	DESCRIPTION
36	Rpt Zn1 ONLY if Armed (N)_	✓	✓	[Y], [N]	Report alarms on zone 1 ONLY if the conditional zone (zone 7 in zone trigger mode; zone 4 in 4204 mode; or zone 8 in 2-4204 mode) is triggered (armed). If [N], always reports alarms on zone 1.
37	Invert Zn2 Y/N (N)_	✓		[Y], [N]	Inverts the alarm and normal states of the zone 2 trigger; otherwise uses normal input signal.
38	Restore Zn2 Y/N (Y)_	✓	✓	[Y], [N]	Enables restore reporting for zone 2. UL/ULC: Must be set to "Y."
39	Delay Zn2 (secs) (00)_	✓	✓	[01-15] [00] = no delay	Defines the reporting delay in seconds for zone 2. UL/ULC: Must be set to "00."
40	Rpt Zn2 ONLY if Armed (N)_	✓	✓	[Y], [N]	Reports alarms on zone 2 ONLY if the conditional zone (zone 7 in zone trigger mode; zone 4 in 4204 mode; zone 8 in 2-4204 mode) is triggered (armed). If [N], always reports alarms on zone 2.
If Lynx Panic is enabled, then skip to Prompt 45: "Rpt Zn3 ONLY if Armed."					
41	Zn3 Trigger Type (V+)_	✓		<ul style="list-style-type: none"> • (V+) • (V-) • (EOLR) 	Selects the triggering method for this zone input. Press the [space] key to scroll through choices. UL: V+ must be set as inverted and V- as non-inverted.
42	Invert Zn3 Y/N (N)_	✓		[Y], [N]	Inverts the alarm and normal states of the zone 3 trigger; otherwise uses normal input signal.
43	Restore Zn3 Y/N (Y)_	✓	✓	[Y], [N]	Enables restore reporting for zone 3. UL/ULC: Must be set to "Y."
44	Delay Zn3 (secs) (00)	✓	✓	[01-15] [00] = no delay	Defines the reporting delay in seconds for zone 3. UL/ULC: Must be set to "00."
45	Rpt Zn3 ONLY if Armed (N)_	✓	✓	[Y], [N]	Reports alarms on zone 3 ONLY if the conditional zone (zone 7 in zone trigger mode; zone 4 in 4204 mode; zone 8 in 2-4204 mode) is triggered (armed). If [N], always reports alarms on zone 3. 4204 mode: If any zone is programmed to "Report Only if Armed," skip to Prompt 56: "Enable Zn6."
46	Zn4 Trigger Type (V+)_	✓		<ul style="list-style-type: none"> • (V+) • (V-) • (EOLR) 	Selects the triggering method for this zone input. Press the [space] key to scroll through choices. UL: V+ must be set as inverted and V- as non-inverted.
47	Invert Zn4 Y/N (N)_	✓		[Y], [N]	Inverts the alarm and normal states of the zone 4 trigger; otherwise uses normal input signal.
48	Restore Zn4 Y/N (Y)_	✓	✓	[Y], [N]	Enables restore reporting for zone 4. UL/ULC: Must be set to "Y."
49	Delay Zn4 (secs) (00)	✓	✓	[01-15] [00] = no delay	Defines the reporting delay in seconds for zone 4. UL/ULC: Must be set to "00."
50	Rpt Zn4 ONLY if Armed (N)_	✓	2-4204 only	[Y], [N]	Reports alarms on zone 4 ONLY if the conditional zone (zone 7 in zone trigger mode; zone 8 in 2-4204 mode) is triggered (armed). If [N], always reports alarms on zone 4.

	PROMPTS	ZONE TRIG.	4204/ 2-4204	OPTIONS	DESCRIPTION
51	Zn5 Trigger Type (V+)_	✓		<ul style="list-style-type: none"> • (V+) • (V-) • (EOLR) 	Selects the triggering method for this zone input. Press the [space] key to scroll through the choices. UL: V+ must be set as inverted and V- as non-inverted.
52	Invert Zn5 Y/N (N)_	✓		[Y], [N]	Inverts the alarm and normal states of the zone 5 trigger; otherwise uses normal input signal.
53	Restore Zn5 Y/N (Y)_	✓	2-4204 only	[Y], [N]	Enables restore reporting for zone 5. UL/ULC: Must be set to "Y."
54	Delay Zn5 (secs) (00)_	✓	2-4204 only	[01-15] [00] = no delay	Defines the reporting delay in seconds for zone 5. UL/ULC: Must be set to "00."
55	Rpt Zn5 ONLY if Armed (N)_	✓	2-4204 only	[Y], [N]	Reports alarms on zone 5 ONLY if the conditional zone (zone 7 in zone trigger mode; zone 8 in 2-4204 mode) is triggered (armed). If [N], always reports alarms on zone 5.
56	Enable Zn6 Y/N (N)_		4204 only	[Y], [N]	Enables alarm reporting for zone 6. If [N], skip to Prompt 62: "Enable Zn7."
57	Zn6 Trigger Type (V+)_	✓	4204 only	<ul style="list-style-type: none"> • (V+) • (V-) • (EOLR) 	Selects the triggering method for this zone input. Press the [space] key to scroll through choices. UL: V+ must be set as inverted and V- as non-inverted.
58	Invert Zn6 Y/N (N)_	✓	4204 only	[Y], [N]	Inverts the alarm and normal states of the zone 6 trigger; otherwise uses normal input signal.
59	Restore Zn6 Y/N (Y)_	✓	✓	[Y], [N]	Enables restore reporting for zone 6. UL/ULC: Must be set to "Y."
60	Delay Zn6 (secs) (00)_	✓	✓	[01-15] [00] = no delay	Defines the reporting delay in seconds for zone 6. UL/ULC: Must be set to "00."
61	Rpt Zn6 ONLY if Armed (N)_	✓	✓	[Y], [N]	Reports alarms on zone 6 ONLY if the conditional zone (zone 7 in zone trigger mode; zone 4 in 4204 mode; zone 8 in 2-4204 mode) is triggered (armed). If [N], always reports alarms on zone 6.
62	Enable Zn7 Y/N (N)_		4204 only	[Y], [N]	Enables alarm reporting for zone 7. If [N], skip to Prompt 70: "Use DHCP."
63	Zn7 Trigger Type (V+)_	✓	4204 only	<ul style="list-style-type: none"> • (V+) • (V-) • (EOLR) 	Selects the triggering method for this zone input. Press the [space] key to scroll through choices. UL: V+ must be set as inverted and V- as non-inverted.
64	Invert Zn7 Y/N (N)_	✓	4204 only	[Y], [N]	Inverts the alarm and normal states of the zone 7 trigger; otherwise uses normal input signal.
65	Restore Zn7 Y/N (Y)_	✓	✓	[Y], [N]	Enables restore reporting for zone 7. Zone Trigger mode: This question will only be displayed if zone 7 is not used as the conditional (arming) trigger zone. UL/ULC: Must be set to "Y."

	PROMPTS	ZONE TRIG.	4204/ 2-4204	OPTIONS	DESCRIPTION
66	Delay Zn7 (secs) (00)_	✓	✓	[01-15] [00] = no delay	Defines the reporting delay in seconds for zone 7. Zone Trigger mode: This question will only be displayed if zone 7 is not used as the conditional (arming) trigger zone. UL/ULC: Must be set to "00."
67	Rpt Zn7 ONLY if Armed (N)_		✓	[Y], [N]	Reports alarms on zone 7 ONLY if the conditional zone (zone 4 in 4204 mode; zone 8 in 2-4204 mode) is triggered (armed). If [N], always reports alarms on zone 7. 2-4204 mode: If any zone is programmed to "Report Only if Armed," or if tamper is enabled, skip to Prompt 70: "Use DHCP."
68	Restore Zn8 Y/N (Y)_		2-4204 only	[Y], [N]	Enables restore reporting for zone 8. UL/ULC: Must be set to "Y."
69	Delay Zn8 (secs) (00)_		2-4204 only	[01-15] [00] = no delay	Defines the reporting delay in seconds for zone 8. UL/ULC: Must be set to "00."
70	Use DHCP Y/N (Y)_	✓	✓	[Y], [N]	Dynamically allocates the IP addresses (recommended); then skip to Prompt 75: "Enable Pwr Save". If [N], uses fixed IP addresses.
71	NIC IP Address: 255.255.255.255_	✓	✓	12 digit: xxx.xxx.xxx.x xx	Enter the 4-part address for this device. The 4 parts of the address must be separated by spaces (displayed as periods in Review mode).
72	Subnet Mask: 255.255.255.255_	✓	✓	12 digit: xxx.xxx.xxx.x xx	Enter the 32-bit address mask used to indicate the portion (bits) of the IP address that is being used for the subnet address. The 4 parts of the address must be separated by spaces (displayed as periods in Review mode).
73	Gateway IP Addr: 255.255.255.255_	✓	✓	12 digit: xxx.xxx.xxx.x xx	Enter the 4-part address assigned to the Gateway. The 4 parts of the address must be separated by spaces (displayed as periods in Review mode).
74	DNS Serv IP Addr: 255.255.255.255_	✓	✓	12 digit: xxx.xxx.xxx.x xx	Enter the 4-part IP address assigned to the DNS (Domain Name System) server. The 4 parts of the address must be separated by spaces (displayed as periods in Review mode).
75	Enable Pwr Save (N)_	✓	✓	[Y], [N]	To meet the 24 hour UL battery backup requirement, choose "Y" to enable this feature. If this causes connectivity problems with certain routers or switches, then choose "N" and wire the communicator so it is powered from a UL listed UPS.
76	IP Connection (Present)	✓	✓	• Present • Auto Detect	Press the [space] key to toggle between the options. Press [ENTER] to select the configuration. If "Present" is chosen, it is assumed that an IP is connected to the device. If it is not detected, a Primary Comm Path Failure message will be delivered after the programmed fault time expires. If "Auto Detect" is chosen, the device will always try to use IP to communicate but it will not generate a Primary Comm Path Failure unless it previously detected the presence of IP. As soon as the presence of IP is detected, a Primary Comm Path Restore message is generated and the value of IP Connectivity programming parameter is changed from "Auto Detect" to

	PROMPTS	ZONE TRIG.	4204/ 2-4204	OPTIONS	DESCRIPTION
					“Detected”. From this point on, the software expects connectivity. The auto detect logic will resume only when the parameter is changed back to “Auto Detect”.
77	Review? Y/N	✓	✓	[Y] = review [N] = exit	Reviewing Programming Mode Entries To review the programming options (to ensure that the correct entries have been made), press [Y]. The programming questions are displayed again. Use the up/down arrow keys to scroll through the program fields without changing any of the values. If a value requires change, simply type in the correct value. When the last field is displayed, the “REVIEW?” question again appears. To exit the programming mode , press [N] in response to the “REVIEW?” question, and refer to <i>Exiting Programming Mode</i> below.

Exiting Programming Mode

To exit the programming mode, press [N] in response to the "REVIEW?" question. Then press [Y] to the "Exit Prog Mode?" question. Upon exiting, the root file is updated to log the changes made. A message is displayed telling the user that this step is being executed. When complete, the message "DONE" is displayed to indicate the file was successfully uploaded.



If critical configuration changes were made, such as the mode of operation, the communicator will reset to ensure that the programming features are enabled.

If the file is not successfully uploaded, one of the following prompts will be displayed. Follow the steps shown below until the upload is successful.

Display	Description	What to do
Cannot Upload Try Again? Y/N_	Communicator is not yet initialized.	Wait for RSSI LEDs to be lit. Press [Y].
Failed to Update Root File!	Network problem, or you answered "N" to "Cannot Upload Try Again?" prompt.	Initiate the Force Server Update Command by pressing the [0] key; refer to <i>Section 5: Programmer Keyboard Commands</i> .

Setting Factory Defaults

To reset the programming options to factory-default values, press [ESC] at the "Exit Prog Mode?" prompt.

Set Default?
Y/N_

Press [Y] to reset factory default values.
Press [N] to cancel this function.

If you press [Y], all programmed values are reset to the original factory settings. PLEASE NOTE THAT THIS WILL ERASE ANY PASSWORD THAT MAY HAVE BEEN ENTERED. After pressing [Y], the Create Password prompt appears (see Prompt 4).

Registration

Registering the Communicator

Once you have initialized and programmed the communicator, it must be registered to enable the account. The registration status is indicated below:

LED	DESCRIPTION
STATUS (green)	ON – Is NOT registered with AlarmNet. OFF – Is registered with AlarmNet.
MESSAGE (yellow)	ON – Message transmission pending. QUICK PERIODIC BLINK - Normal SLOW BLINK – In unison with green LED, Registration in progress.
FAULT (red)	OFF – No fault present.

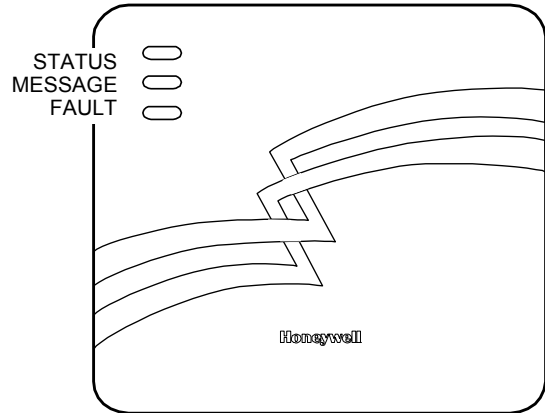

Upon completion of the registration process, the communicator transmits a registration message and receives a registration validation indicating that the account is now enabled. Wait for the "Registration Success" message to appear, regardless of which registration method used.

You can register the communicator by one of the following methods:

- Through the AlarmNet Direct website
- Through use of the Tamper Switch
- Through use of a 7720P Programming Tool
- By phone

Register through the AlarmNet Direct Website

The communicator can be registered through the AlarmNet Direct Website. To program the communicator via the website (if you are already signed up for this service), go to:

<https://services.alarmnet.com/AlarmNetDirect/>

Log in and follow the on-screen prompts.

If you are not signed up for this service, click on "Dealer Signup" from the login screen to gain access to the Honeywell web-based programming.

Dealer Sign-Up Direct Link: https://services.alarmnet.com/AlarmnetDirectP_SignUp/

You will be instructed how to proceed upon completing the sign-up form. Only one sign-up per dealer is required. Once an initial user is established, additional logins may be created by that user.

NOTE: Central Stations sign up by contacting AlarmNet Administration at 800-222-6525 option 3.

Please have the following information available when programming the device:

- Primary City ID (two-digit number)
- Primary Central Station ID (two-digit hexadecimal number)
- Primary Subscriber ID (four-digit number)

- MAC ID and MAC CRC number (located on the box and inside the communicator)
- Once the communicator is registered, you may log out of the AlarmNet Direct website.

Register using the Tamper Switch

Initiate the registration sequence by clicking the Tamper Switch three times.

You can monitor the registration process by viewing the Status Display. The Message (yellow) LED and the Status (green) LED will blink slowly in unison while registration is in progress.

Once the registration has been completed successfully, the communicator enters normal operating mode; the Status (green) LED goes out and the Message (yellow) LED is lit to indicate that the Power On / Reset message is waiting to be sent. This message will appear at the receiving station as “E339 C08xx”, where “xx” is the ECP device address. The description may read “Trouble – Exp. Mod. Reset”. If registration is not validated within 90 seconds, the communicator times out, and the (green) LED will be lit (solid).

The Power On / Reset message will be sent in ADEMCO High-Speed format if the communicator is programmed for zone trigger, 4204 or 2x4204 modes.

If repeated registration attempts time out, check your Internet connection and RSSI level, and verify the communicator account information has been entered correctly.

Register using the Programming Tool

The interactive registration feature allows the installer to register the communicator through a series of keyboard commands on the 7720P Programming Tool. This method of registration lets the installer monitor the registration process.

Registering ...

Once the installation is complete, press the [Shift] and the up arrow [↑] key on the 7720P. The registration message is sent and the unit waits for the acknowledgment.

Registration
SUCCESS

If this is a new installation and the city, central station, and customer numbers have been correctly entered, the communicator is registered and this message is displayed. The communicator is now in full service and available for alarm reporting to the central station.

Possible Errors

Registration BAD
Timed Out

Displayed if no response to the registration request is received.

Registration BAD
Pri Sub ID BAD

Indicates the city, central station, or customer number for the labeled account(s) is not accepted. The ID information was either entered incorrectly, or the central station failed to pre-authorize programmed ID numbers with AlarmNet customer service.

Registration BAD
2nd Sub ID BAD

Indicates the city, central station, or customer number for the Secondary account is not accepted. The ID information was either entered incorrectly, or the central station failed to pre-authorize programmed ID numbers with AlarmNet customer service.

Registration BAD
Pri&Sec – IDs BAD

Displayed when both primary and secondary subscriber IDs are invalid.

Registration BAD
Pri ID – Need PIN

Displayed if this is a repair/replacement, or an error was made in programming the Primary account information of the communicator for an existing account. This prompt appears for 2 seconds. See the *Replacing an existing communicator* section below for further displays.

Registration BAD
2nd ID – Need PIN

This prompt is displayed if this is a repair/replacement, or an error was made in programming the Secondary account information of the communicator for an existing account. This prompt appears for 2 seconds. See the *Replacing an existing communicator* section below for further displays.

Registration BAD
Pri&2nd – Need PIN

This prompt is displayed if this is a repair/replacement, or an error was made in programming BOTH the Primary and Secondary account information of the communicator for an existing account. This prompt appears for 2 seconds. See the *Replacing an existing communicator* section below for further displays.

Replacing an existing communicator

Enter PIN#

This prompt appears after pressing the [Shift] and down arrow [↓] on the 7720P.

Note: If it is necessary to exit registration mode, press ESC from the 7720P programming tool.

Enter a 4-digit alphanumeric PIN number provided by your central station, your dealer or an authorized AlarmNet representative.

Press the [Enter] key.

Registering ...

The registration message is sent and the unit waits for acknowledgement.

Registration
SUCCESS

If the PIN is valid, the new communicator is registered and the old unit unregistered. Additionally, AlarmNet sends a substitution alarm to the central station.

Registration BAD

If you entered an invalid PIN, the appropriate message is displayed depending on which account number is being replaced (see above for exact wording). The registration process is repeated.

NOTE: Each attempt causes a substitution alarm to be sent to the central station.

Register by Phone

You can register the communicator by calling the AlarmNet Technical Assistance Center (TAC) at 1-800-222-6525. You will need the following information:

- MAC number (found on the box and inside the communicator).
- Subscriber information (provided by the central station), including a city code, CSID, and a subscriber ID.
- When instructed to do so, triple-click the tamper switch to complete the registration.

Programmer Keyboard Commands

Programmer Keyboard Commands

Programmer keyboard commands can be used to quickly view your connectivity settings and options. Most commands require you to press the [Shift] key and then the designated command key. (See the keys designated in red on the 7720P Programming Tool.)

[A]	<table border="1"> <tr> <td>7845iGSM</td> <td>RIS</td> </tr> <tr> <td>x.x.xx</td> <td>mm/dd/yy</td> </tr> </table>	7845iGSM	RIS	x.x.xx	mm/dd/yy	<p>Software Revision "x.x.xx" indicates the installed software Revision. Mm/dd/yy indicates month, day and year of the revision.</p>
7845iGSM	RIS					
x.x.xx	mm/dd/yy					

Identification Displays

[B]	<table border="1"> <tr> <td>MAC</td> <td>xxxxxxxxxxxx</td> </tr> <tr> <td>MAC CRC</td> <td>yyyy</td> </tr> </table> <table border="1"> <tr> <td>SCID</td> <td>xxxxx</td> <td>xxxxx</td> </tr> <tr> <td></td> <td>xxxxx</td> <td>xxxxx</td> </tr> </table> <table border="1"> <tr> <td>IMEI</td> <td>xxxxxxxx</td> </tr> <tr> <td></td> <td>xxxxxx x</td> </tr> </table>	MAC	xxxxxxxxxxxx	MAC CRC	yyyy	SCID	xxxxx	xxxxx		xxxxx	xxxxx	IMEI	xxxxxxxx		xxxxxx x	<p>MAC Address "xxxxxxxxxxxx" indicates the communicator's unique identification number. "yyyy" indicates the MAC CRC number. This number is found on the box and inside the communicator. Press the [Space] key to go to the next field. Press the backspace [BS] key to go to the IMEI display.</p> <p>SCID Display Displays the identification number assigned to the SIM card (SCID) in this device. Press the [Space] key to go to the next field. Press the backspace [BS] key to go to the previous field.</p> <p>IMEI Display Displays the identification number assigned to the communicator. Press the [Space] key to get the MAC Address. Press the backspace [BS] key to go to the previous field.</p>
MAC	xxxxxxxxxxxx															
MAC CRC	yyyy															
SCID	xxxxx	xxxxx														
	xxxxx	xxxxx														
IMEI	xxxxxxxx															
	xxxxxx x															
[C]	<table border="1"> <tr> <td>Mon 01 Jan 2001</td> </tr> <tr> <td>05:48:39 am</td> </tr> </table>	Mon 01 Jan 2001	05:48:39 am	<p>Time Retrieves the current date and time from the AlarmNet network in Greenwich Mean Time (GMT). This display confirms that the communicator is in sync with network.</p>												
Mon 01 Jan 2001																
05:48:39 am																
[D]	<table border="1"> <tr> <td>Physical Link</td> </tr> <tr> <td>Good/Bad</td> </tr> </table> <table border="1"> <tr> <td>NIC IP Address</td> </tr> <tr> <td>xxx.xxx.xxx.xxx</td> </tr> </table>	Physical Link	Good/Bad	NIC IP Address	xxx.xxx.xxx.xxx	<p>Network Diagnostics Display Indicates whether the device has detected a physical connection to the internet. Press the [Space] key to go to the next field.</p> <p>IP Information Display Displays the IP address assigned to this device. Press the [Space] key to go to the next field.</p>										
Physical Link																
Good/Bad																
NIC IP Address																
xxx.xxx.xxx.xxx																

Subnet Mask xxx.xxx.xxx.xxx	Displays the 32-bit address mask used to indicate the portion (bits) of the IP address that is being used for the subnet address. Press the [Space] key to go to the next field. Press the backspace [BS] key to go to the previous field.
Gateway IP Addr xxx.xxx.xxx.xxx	Displays the IP address assigned to the Gateway. Press the [Space] key to go to the next field. Press the backspace [BS] key to go to the previous field.
DNS Serv IP xxx.xxx.xxx.xxx	Displays the IP address assigned to the DNS (Domain Name System) server. Press the [Space] key to go to the next field. Press the backspace [BS] key to go to the previous field.
Encryption Test AES Passed!	Performs a self-test of the AES encryption algorithm. Press the [Space] key to go to the next field. Press the backspace [BS] key to go to the previous field.
DHCP OK	DHCP (Dynamic Host Configuration Protocol) indicates server is performing satisfactorily. Press the [Space] key to go to the Physical Link display.

GSM Status Displays

[E]	Operating with 3G/4G service								
PriRSSI 3/4G REG -xxxdbm stat x	<p>Status Display Screen 1 PriRSSI – Primary site RSSI level in dBm. 3/4G – Communicator is on the 3G/4G network where “stat” can be:</p> <table style="margin-left: 40px;"> <tr><td>Good</td><td>RSSI –20 to –90 dBm</td></tr> <tr><td>OK</td><td>RSSI –91 to –99 dBm</td></tr> <tr><td>Marginal</td><td>RSSI –100 to –105 dBm</td></tr> <tr><td>Bad</td><td>RSSI –106 to –150 dBm</td></tr> </table> <p>REG – Registration status where “x” can be: N – Not Registered H – Registered Home S – Searching D – Registration Denied R – Registered Roaming ? – Unknown Registration State</p> <p>Press the [space] key to go to the next screen. Press the [backspace] key to go to the last screen.</p>	Good	RSSI –20 to –90 dBm	OK	RSSI –91 to –99 dBm	Marginal	RSSI –100 to –105 dBm	Bad	RSSI –106 to –150 dBm
Good	RSSI –20 to –90 dBm								
OK	RSSI –91 to –99 dBm								
Marginal	RSSI –100 to –105 dBm								
Bad	RSSI –106 to –150 dBm								
RAT EC/NO 3G/4G -xxxxx	<p>Status Display Screen 2 RAT – Radio Access Technology. EC/NO – Carrier Noise Ratio (CNR) Press the [space] key to get to the next screen. Press the [backspace] key to go to the previous field.</p>								

CNtry	NetW	LAC
xxx	xxx	xxxxx

Status Display Screen 3

CNtry – Country Code
 NetW – Network Code
 LAC – Local area code
 Press the [space] key to get to the next screen.
 Press the [backspace] key to go to the previous field.

Cell	CHan	PSC
xxxxxxx	xxxx	xxx

Status Display Screen 4

Cell – Base Station ID
 CHan – Control Channel in use
 PSC – Primary Sync Code
 Press the [space] key to go to the next screen.
 Press the [backspace] key to go to the previous field.

Second Site Available	RSSI
-----------------------	------

Status Display Screen 5

Secondary Site RSSI availability. Available or Not Available will be displayed.
 Press the [space] key to go to Status Display Screen 1.
 Press the [backspace] key to go to the previous field.

[E] **Operating with 2G service**

PriRSSI	2G	REG
-xxxdbm	stat	x

Status Display Screen 1

PriRSSI – Primary site level in dBm.
 2G – Communicator is on the 2G network where “stat” can be:

- Good RSSI –20 to –89 dBm
- OK RSSI –90 to –98 dBm
- Marginal RSSI –99 to –104 dBm
- Bad RSSI –105 to –150 dBm

REG – Registration status where “x” can be:

- N – Not Registered
- H – Registered Home
- S – Searching
- D – Registration Denied
- R – Registered Roaming
- ? – Unknown Registration State

Press the [space] key to go to the next screen.
 Press the [backspace] key to go to the last screen..

RAT	EC/NO
2G	NA

Status Display Screen 2

RAT – Radio Access Technology.
 EC/NO – Carrier Noise Ratio (CNR). This is not a 2G parameter, therefore, NA is displayed.
 Press the [space] key to get to the next screen.
 Press the [backspace] key to go to the previous field.

<table border="1"> <tr> <td>CNtry</td> <td>NetW</td> <td>LAC</td> </tr> <tr> <td>xxx</td> <td>xxx</td> <td>xxxxx</td> </tr> </table>	CNtry	NetW	LAC	xxx	xxx	xxxxx	<p>Status Display Screen 3 CNtry – Country Code NetW – Network Code LAC – Local area code Press the [space] key to get to the next screen. Press the [backspace] key to go to the previous field.</p>
CNtry	NetW	LAC					
xxx	xxx	xxxxx					
<table border="1"> <tr> <td>Cell</td> <td>BaseST</td> <td>Chan</td> </tr> <tr> <td>xxxx</td> <td>xxxx</td> <td>xxx</td> </tr> </table>	Cell	BaseST	Chan	xxxx	xxxx	xxx	<p>Status Display Screen 4 Cell – Base Station ID BaseST – Base Station Antenna Sector Chan – Control Channel in use Press the [space] key to go to the next screen. Press the [backspace] key to go to the previous field.</p>
Cell	BaseST	Chan					
xxxx	xxxx	xxx					
<table border="1"> <tr> <td>Second Site Available</td> <td>RSSI</td> </tr> </table>	Second Site Available	RSSI	<p>Status Display Screen 5 Secondary Site RSSI availability. Available or Not Available will be displayed. Press the [space] key to go to Status Display Screen 1. Press the [backspace] key to go to the previous field.</p>				
Second Site Available	RSSI						

<p>[F]</p> <table border="1"> <tr> <td>Testing Gateway Redir 1</td> </tr> </table>	Testing Gateway Redir 1	<p>Run Network Diagnostic Test Performs a set of network diagnostics that tests the integrity of the links between the communicator and the various connection points (Redirs) to AlarmNet. Refer to Section 6: <i>Network Diagnostics</i>.</p>
Testing Gateway Redir 1		

System Status Displays

<p>[S]</p> <table border="1"> <tr> <td>ECP 67 TmPB Flt xx 5 ++ OK</td> </tr> </table>	ECP 67 TmPB Flt xx 5 ++ OK	<p>ECP Mode Displays the zone and system fault status. Press the [Space] key to go to the next field. Press the backspace [BS] key to go to the previous field.</p>
ECP 67 TmPB Flt xx 5 ++ OK		
<table border="1"> <tr> <td>1234 67 TmPB Flt 5555 xx 5 ++ OK</td> </tr> </table>	1234 67 TmPB Flt 5555 xx 5 ++ OK	<p>4204 Emulation Mode Displays the zone and system fault status. Press the [Space] key to go to the next field. Press the backspace [BS] key to go to the previous field.</p>
1234 67 TmPB Flt 5555 xx 5 ++ OK		
<table border="1"> <tr> <td>12345678 TmPB Flt 5555555x 5 ++ OK</td> </tr> </table>	12345678 TmPB Flt 5555555x 5 ++ OK	<p>Two-4204 Emulation Mode Displays the zone and system fault status. Press the [Space] key to go to the next field. Press the backspace [BS] key to go to the previous field.</p>
12345678 TmPB Flt 5555555x 5 ++ OK		
<table border="1"> <tr> <td>1234567 TmPB Flt 5555555 5 ++ OK</td> </tr> </table>	1234567 TmPB Flt 5555555 5 ++ OK	<p>Zone Trigger Mode The status of the communicator can be viewed on the 7720P. The status display includes:</p> <ul style="list-style-type: none"> • Zone input status (1234567) - the numbers 1-7 represent the 7 mappings of the zone input, and follow Honeywell's ADEMCO high-speed format codes: <ul style="list-style-type: none"> 1 = New Event 5 = Normal X = Not Enabled • Tm – Tamper status follows high-speed format codes
1234567 TmPB Flt 5555555 5 ++ OK		

above.

- **P** – Represents line voltage as follows:
 + = Power line voltage OK
 – = Power line voltage bad and reported
 V = Power line voltage bad, not reported (reporting window not expired)
 ^ = Power voltage restored, not yet reported
- **B** – Represents battery condition as follows:
 + = Battery voltage acceptable
 – = Battery voltage below 5.7V ±5%
- **Flt** – Represents radio faults:
OK = Normal ; No fault
I – No network connectivity over IP and fault time has expired
i – No network connectivity over IP and fault time has NOT yet expired.
G = No network connectivity over GSM and fault time has expired.
g = No network connectivity over GSM and fault time has NOT yet expired.

NOTE: The 7720P will not operate if the power line voltage is removed.

Bat NLd: x.xxV Bat Ld: x.xxV

Battery Voltage Display

The voltage levels of the battery connected to the communicator can be viewed on the 7720P. The first line of the display shows the voltage level of the battery with no load. The second line of the display shows loaded battery voltage. An asterisk (*) next to the voltage indicates that this is below the accepted level.

Press the [Space] key to go to the next field.

Press the backspace [BS] key to go to the previous field.

Battery Charger OK

Battery Charger

Indicates the battery charger circuit status (either OK or NOT OK).

Press the [Space] key to go to the next field.

Press the backspace [BS] key to go to the previous field.

Line Voltage xx.xxV

Line Voltage Display

The line voltage [this value is the peak voltage from the power transformer or RMS x 1.414] of the communicator can be viewed on the 7720P. An asterisk (*) next to the voltage indicates that this is below the accepted level.

Press the [Space] key to go back to the System Status Display.

Press the backspace [BS] key to go to the previous field.

[T] Test Msg Sent

Test Alarm

Sends a Test alarm to AlarmNet. Functional for a *registered* communicator only. If the device is not registered, a message is displayed indicating that the command cannot be executed.

[X] Reset CPU Y/N

Reset the Communicator.

Pressing [N] returns to diagnostic mode (blank screen = enter next command or escape).

Pressing [Y] resets the communicator (blank screen = reset complete).

[↑] (UP arrow)	Registering ...	Registration Registers a programmed communicator with AlarmNet.
[↓] (DN arrow)	Enter PIN#	Registration with PIN for Replacement Communicator Registers a replacement communicator with AlarmNet, once programmed, using the existing PIN #.
[0]	Force Server Update? Y/N	Force Upload of Configuration File to Server Pressing [Y] will force the device to upload its entire configuration file to the server. Pressing [N] cancels the operation. NOTE: If the internet is not available, and the communicator is not initialized when you enter this command, the following screen will be displayed: <div data-bbox="740 646 967 709" style="border: 1px solid black; padding: 2px; width: fit-content; margin: 5px auto;">Cannot Upload Try Later! _</div> Wait for the RSSI LEDs to light, indicating the communicator has completed its initialization, and try again.
[ENT ER]	Strt Prog Mode? Y/N_	Enter Program Mode Press [Y] to enter program mode; otherwise, press [N].

Network Diagnostics

Running Network Diagnostics

The network diagnostic process tests the integrity of the links between the communicator and the various connection points of AlarmNet Control that are known as "Redirects" (Redirs or RDR).

To initiate the network diagnostics, press the [F] key on the 7720P Programming Tool.

NOTE: The test is performed ONLY if a physical link is detected. If no physical link is detected, the test is aborted and the following is displayed:

NO PHYSICAL LINK

If a physical link is detected, the diagnostics are performed. The following shows the progression of the test:

Testing Redir 1

The first step of the test traces the connection to Redir 1 at AlarmNet Control.

Testing Redir 2
Reached Gateway

A successful trace to Redir 1 is indicated here. See below for possible errors that may occur at this stage of testing.

Redir 1
Service OK

The service at AlarmNet Control on Redir 1 is functioning. See below for possible errors that may occur at this stage of testing.

Testing Redir 2

The first step of the test traces the connection to Redir 2 at AlarmNet Control.

Redir 2
Service OK

The service at AlarmNet Control on Redir 2 is functioning. See below for possible errors that may occur at this stage of testing.

Testing Redir 3

The first step of the test traces the connection to Redir 3 at AlarmNet Control.

Redir 3
Service OK

The service at AlarmNet Control on Redir 3 is functioning. See below for possible errors that may occur at this stage of testing.

RDR1 RDR2 RDR3
OK OK OK

A summary of the tests is displayed after Redir 3 is tested. The example shows that the tests of all three connection points, or Redirs, were successful. If an error occurred at any point, the summary will display "FAIL" under the faulty Redir.

Possible Errors Running Network Diagnostics

Errors may occur either while tracing the connection to a given Redir or while testing the service at a given Redir. The following list highlights the most common errors. Please contact the AlarmNet Technical Assistance Center (TAC) for help regarding any errors NOT listed below:

Possible Errors

Testing Redir x FAIL before Gtwy	While tracing the connection to Redir x, the trace fails before ever reaching the local gateway (router).
Testing Redir x FAIL at Gtwy	While tracing the connection to Redir x, the trace fails after reaching the local gateway (router).
Testing Redir x FAIL at Pvt IP	While tracing the connection to Redir x, the trace fails after reaching the private IP.
Testing Redir x FAIL on IP Addr	While tracing the connection to Redir x, the trace fails after reaching the public IP.
Redir x ERR:Proxy 18	After a successful trace to Redir x, the test of the network service timed out without a response.

Appendix A: Summary of LED Operation

Note: If all LEDs FAST BLINK in unison with the RSSI LEDs this indicates a Hardware Error.

GRN	ON – NOT registered with AlarmNet. OFF – Registered with AlarmNet. FAST BLINK – Download session with Compass in progress. SLOW BLINK – In unison with yellow LED, registration in progress.
YEL	ON – Message transmission pending. QUICK PERIODIC BLINK – Normal. FAST BLINK – Message waiting for network ACK. SLOW BLINK – Idle power abnormal. SLOW BLINK – In unison with green LED, registration in progress.
RED	ON – No contact with network. OFF – Normal. SLOW BLINK – Loss of communication with the panel (ECP fault). FAST BLINK – No network contact AND loss of communication with the panel.

Cellular Status LED

Voice Session – Short blink every second
Data Session – Short blink every 2 seconds
Connected to Cell network – Short blink every 4 seconds
No or deactivated SIM – Long blink every second

RSSI / MODE AND STATUS LEDs

MODULE'S RECEIVED SIGNAL STRENGTH (RSSI)

When the **Mode Switch** is NOT depressed, LED 1 will illuminate red.

- The remaining LEDs indicate RSSI (Received Signal Strength).

MODULE'S OPERATION MODE

When the **Mode Switch** IS depressed, LED 1 will be OFF.

- LEDs 2 and 3 indicate the module's communication mode with the control panel.

Mode	LED 2 (yellow)	LED 3 (yellow)
ECP	OFF	OFF
Zone	ON	OFF
4204	OFF	ON
2 - 4204	ON	ON

MODULE'S STATUS

When the **Mode Switch** IS depressed, LED 1 will be OFF.

- LEDs 4, 5, and 6 indicate the module's Status.

LED 4 (green)	LED 5 (green)	LED 6 (green)
ON - Connected to Internet. OFF - Not connected to Internet.	ON - GPRS service available. OFF - No GPRS service available. FAST BLINK - GPRS in use.	ON - Module registered, no second site available. OFF - Module not registered with network carrier. SLOW BLINK - Module registered, second site available, and low signal strength. NORMAL BLINK - Module registered, second site available, acceptable signal strength. FAST BLINK - Module registered, second site available, excellent signal strength.

Ethernet Link/Activity GREEN	ON – Link detected. OFF – No link detected. BLINKS – Network activity.
Link Speed GREEN	ON – 100 MB/S link to Internet. OFF – 10 MB/S link to Internet.

IGSMV4G-010-V1

Appendix B: Central Station Messages

Alarm Condition	ECP Mode		Zone and 4204 Modes	
	Alarm Code	Restore Code	Alarm Code	Restore Code
Power On / Reset	E339 C08xx*		5551 5555 6	
Tamper (Compromise Indication)	E341 C08xx*	R341 C08xx*	5555 5551 7	5555 5553 7
Power Loss	E337 C08xx*	R337 C08xx*	1555 5555 6	3555 5555 6
Low Battery	E338 C08xx*	R338 C08xx*	5155 5555 6	5355 5555 6
Battery Charger Failure	E314 C08xx*	R314 C08xx*	5155 5555 1	5355 5555 1
ECP Supervision (Compromise Indication)	E355 C0000	R355 C0000	5555 5515 5	5555 5535 5
Primary Comm Path Supervision	E350 C0951	R350 C0951	5555 5551 5	5555 5553 5
Secondary Comm Path Supervision	E350 C0952	R350 C0952	5555 5551 1	5555 5553 1
Telco (Compromise Indication)			5555 5155 6	5555 5355 6
Open/Close			2 sent in selected zone	4 sent in selected zone
Periodic GSM Comm Test Failure	E358 C0803			
Test	5555 5555 9		5555 5555 9	
Specific to RESIDENTIAL / COMMERCIAL Control Panels (Such as the VISTA-10P, 15P, and 20P series.)				
UL	The information provided in this section for the VISTA-10P, 15P, and 20P series control panels has not been evaluated with this communicator.			
Communicator Trouble (low battery, ECP bus, network) (Possible Compromise Indication)	E353 C08xx* ◊	R353 C08xx* ‡		
Radio Fault	E353 0 1xx* ‡	R353 0 1xx* ‡		
Specific to COMMERCIAL Control Panels (Such as the VISTA-128/250 series.)				
Communicator Trouble (low battery, ECP bus, network) (Possible Compromise Indication)	E333 C08xx* ‡	R333 C08xx* ‡		
Radio Loss of Signal (Possible Compromise Indication)	E357 0 8xx* †	R357 0 8xx* ‡ or R380 0 8xx* ‡		
Radio Fault (low battery, tamper, ECP Bus)	E333 0 8xx* ‡	R333 0 8xx* ‡		
AlarmNet Messages				
Communication failure. (Possible Compromise Indication)	5555 1555 6	5555 3555 6		
Authorized Radio Substitution	00D0 010C 0			
Unauthorized Radio Substitution Attempt	00D0 010E 0			
Service Termination	00D0 020E 0			

* xx = Communicator Device Address

† = Message is sent by dialer only.

‡ = Message is sent by dialer and radio.

◊ = Message is sent by dialer only, or dialer and radio, depending on failure.

Appendix C: Glossary

4G	Refers to the fourth generation of cellular wireless standards. It is a successor to 3G and 2G families of standards. 4G provides up to 10 times the data transfer speeds of 3G.
AES	Advanced Encryption Standard
DACT	Digital Automated Communications Terminal
DHCP	Dynamic Host Configuration Protocol, which provides a mechanism for allocating IP addresses dynamically so that addresses can be reused when hosts no longer need them.
DNS	Domain Name System, which is a distributed hierarchical naming system used to resolve domain names (e.g., www.yahoo.com) into numerical IP addresses (e.g., 204.17.25.1).
DSL	Digital Subscriber Line.
ECP	Enhanced Console Protocol, which is a proprietary bus used in Honeywell control panels to communicate with keypads and peripheral devices. It uses four wires; power, ground, data in, data out.
Gateway IP Address	A gateway (sometimes called a router) is a computer and/or software used to connect two or more networks (including incompatible networks) and translates information from one network to the other. The Gateway IP address is the IP address for the gateway.
GPRS	General Packet Radio Service.
GSM	Global System for Mobile communications, which is an international standard for digital mobile phone systems used for cellular communication.
IMEI	International Mobile Equipment Identity number.
IP	Internet Protocol.
IP Address	A unique number consisting of four parts separated by periods (for example: 204.17.29.11). An IP Address can be fixed or "static", or "dynamic," where the IP Address is assigned via DHCP at every startup.
ISDN	Integrated Services Digital Network.
ISP	Internet Service Provider.
LAN	Local Area Network.
LRR	Long Range Radio, an older term now referred to as communicator. A broader term communications module or communications device may also be used.
MAC ID	Media Access Code, this is a unique address assigned to every network communications device. For the communicator it is located on the box and inside the communicator.
Subnet Mask	A Subnet is a portion of a network that shares a network address with other portions of the network, and is distinguished by a subnet number. The Subnet Mask is a 32-bit address mask used in IP to indicate the bits of an IP address that are being used for the subnet address.
TCP/IP	Transmission Control Protocol / Internet protocol.

NOTES

NOTES

Summary of Connections

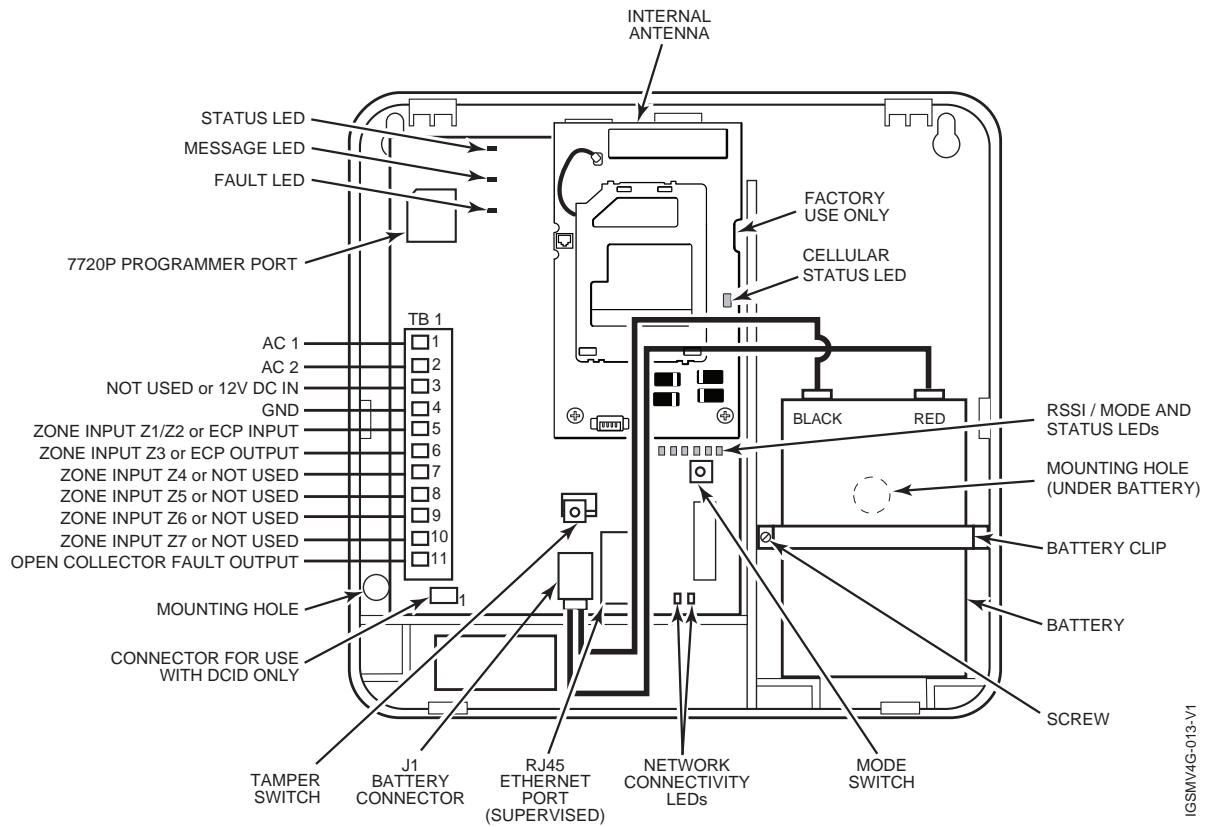

NOTE: All circuits are supervised and all circuits are power limited except the battery.

Communicator TB1 Wiring

TB1	ECP Mode	Zone Trigger Mode	4204 Mode	2 x 4204 Mode
1	AC 1	AC 1	AC 1	AC 1
2	AC 2	AC 2	AC 2	AC 2
3	ECP V+ (RED)	NOT USED	ECP V+ (RED)	ECP V (RED)+
4	GND (BLK)	GND (BLK)	GND (BLK)	GND (BLK)
5	ECP IN (YEL)	Z1/Z2	ECP IN (YEL)	ECP IN (YEL)
6	ECP OUT (GRN)	Z3	ECP OUT (GRN)	ECP OUT (GRN)
7	NOT USED	Z4	NOT USED	NOT USED
8	NOT USED	Z5	NOT USED	NOT USED
9	Z6	Z6	Z6	NOT USED
10	Z7	Z7	Z7	NOT USED
11	FLT OUT	FLT OUT	FLT OUT	FLT OUT

NOTES

NOTES

FEDERAL COMMUNICATIONS COMMISSION STATEMENTS

The user shall not make any changes or modifications to the equipment unless authorized by the Installation Instructions or User's Manual. Unauthorized changes or modifications could void the user's authority to operate the equipment.

CLASS B DIGITAL DEVICE STATEMENT

This equipment has been tested to FCC requirements and has been found acceptable for use. The FCC requires the following statement for your information:

This equipment generates and uses radio frequency energy and if not installed and used properly, that is, in strict accordance with the manufacturer's instructions, may cause interference to radio and television reception. It has been type tested and found to comply with the limits for a Class B computing device in accordance with the specifications in Part 15 of FCC Rules, which are designed to provide reasonable protection against such interference in a residential installation. However, there is no guarantee that interference will not occur in a particular installation. If this equipment does cause interference to radio or television reception, which can be determined by turning the equipment off and on, the user is encouraged to try to correct the interference by one or more of the following measures:

- If using an indoor antenna, have a quality outdoor antenna installed.
- Reorient the receiving antenna until interference is reduced or eliminated.
- Move the radio or television receiver away from the receiver/control.
- Move the antenna leads away from any wire runs to the receiver/control.
- Plug the receiver/control into a different outlet so that it and the radio or television receiver are on different branch circuits.
- Consult the dealer or an experienced radio/TV technician for help.

INDUSTRY CANADA CLASS B STATEMENT

This Class B digital apparatus complies with Canadian ICES-003.

Cet appareil numérique de la classe B est conforme à la norme NMB-003 du Canada.

FCC / IC STATEMENT

This device complies with Part 15 of the FCC Rules, and RSS210 of Industry Canada. Operation is subject to the following two conditions: (1) This device may not cause harmful interference, and (2) This device must accept any interference received, including interference that may cause undesired operation.

Cet appareil est conforme à la partie 15 des règles de la FCC & de RSS 210 des Industries Canada. Son fonctionnement est soumis aux conditions suivantes: (1) Cet appareil ne doit pas causer d'interférences nuisibles. (2) Cet appareil doit accepter toute interférence reçue y compris les interférences causant une réception indésirable.

RF Exposure

Warning – The antenna(s) used for this transmitter must be installed to provide a separation distance of at least 20 cm from all persons and must not be collocated or operating in conjunction with any other antenna or transmitter.

DOCUMENTATION AND ONLINE SUPPORT

For the latest documentation and online support information, please go to:

<http://www.security.honeywell.com/hsc/resources/MyWebTech/>

WARRANTY

For the latest warranty information, please go to:

<http://www.security.honeywell.com/hsc/resources/wa/>

Honeywell



800-10905 1/12 Rev. C

2 Corporate Center Drive, Suite 100
P.O. Box 9040, Melville, NY 11747
Copyright © 2012 Honeywell
International Inc.

www.security.honeywell.com