

CONVERGENCE

» network «



Model SSP2000B



Model SSP3000B

SmartSiren® Platinum Installation and Maintenance Instructions

Legend, Arjent, Raydian, and SmartSiren are registered trademarks of Federal Signal Corporation
Convergence and SignalMaster are trademarks of Federal Signal Corporation

Contents

Chapter 1 Safety Messages for Installers and Operators	7
Safety Messages to Installers of Sound/Light Systems	7
Safety Messages to Operators of Sound/Light Systems	9
Chapter 2 An Overview of the SmartSiren Platinum	11
Siren, PA, and Speakers	11
Lightbars and SignalMaster™ Control	11
Programmable Solid-State Auxiliary Relays	11
Programmable Input Circuits	12
LED Indicators and Visual Diagnostics (Model SSP3000B Only).....	12
System Specifications	12
Siren Specifications.....	13
SignalMaster Specifications (Model SSP3000B only)	13
Relay Specifications.....	13
SmartSiren Platinum Kit Contents.....	14
Chapter 3 Connecting the Convergence Network	16
Selecting Mounting Locations	16
Overview of the Convergence Network Connections.....	18
Preparing for the Convergence Network Installaton.....	20
Connecting the Convergence Network	20
Connections for 10A Auxiliary Relays.....	21
Connections for Low-Current Auxiliary Relays.....	23
Connections for the Latitude SignalMaster	24
Connections for Rear External Discrete SignalMaster (SSP3000B Only)	25
Connections for Relay Inputs 1 to 4	26
Connections for the Ambient Light Sensor	27
Park Input (Cable Assembly 1751542-01 or 1752542-NY).....	27
Speaker Connections (Cable Assembly P/N 17500307)	28
Horn Ring Transfer (Cable Assembly 17500307)	29
Radio Rebroadcast (Cable Assembly 17500307)	31
Connecting the Control Head	32
Connecting the Active-Low Input Circuits (Cable Assembly 17500308).....	32
Connecting Ignition Power to the Control Head (without Ignition Timer)	33
Connecting Power to the Control Head (with Ignition Timer).....	33
Connecting the Federal Signal Microphone (P/N 258B8577-03)	34
Connecting the Siren to the Battery	35

Contents

Preparing to Connect the Power Leads.....	35
Connecting the Power Leads to the Vehicle Battery	35
Chapter 4 Setting the Gain for Radio Rebroadcast and PA.....	37
Setting the Gain for Radio Rebroadcast.....	37
Setting the Gain for Public Address (Microphone Volume)	38
Chapter 5 Mounting the Siren and Control Head.....	40
Mounting the Siren Amplifier/Relay Module	40
Mounting the Control Head	41
Chapter 6 Setting Control Head Options.....	43
Turning Off or On the 10-Second Notification Beep.....	43
Selecting Active-High Activation of Horn-Ring Transfer	44
Selecting Active-High Activation of the Park Input Circuit	45
Dimming or Turning Off the Button LEDs.....	45
Configuring Keep-Alive Timeout	45
Resetting the Control Head to the Factory Default Configuration	46
Exiting Program Mode.....	46
Chapter 7 Testing the Convergence Network Installation	47
Chapter 8 Control Head Legends and Safety Messages	54
Applying the Replaceable Control Head Legends.....	54
Distributing the Safety Message Card	55
Applying the Siren Safety Labels in the Vehicle	55
Chapter 9 Safety Messages to Personnel Servicing Federal Signal Electronic Sirens	56
Chapter 10 Servicing the Convergence Network System.....	57
Replacing the Slide Switch	57
Dismounting and Disconnecting the Control Head.....	57
Replacing the Slide Switch in the Control Head	59
Reinstalling the Control Head	60
Servicing the Siren Amplifier/Relay Module.....	60
Uninstalling the Siren Amplifier/Relay Module.....	60
Replacing an External Fuse	61
Replacing a Terminal Insulator.....	62
Reinstalling the Siren Amplifier/Relay Module	62
Getting Technical Support and Service.....	63
Ordering Replacement Parts	63
Returning a Product to Federal Signal.....	64

Tables

Table 2.1 SSP2000B kit contents 14

Table 2.2 SSP3000B kit contents 15

Table 3.1 Descriptions of configurable activation options for 10 A relays 22

Table 3.2 Configurable activation options for 2 A solid-state relays 23

Table 3.3 Latitude SignalMaster control wires 24

Table 10.1 Replacement parts 63

Figures

Figure 3.1 Dimensions of the control head 17

Figure 3.2 Dimensions of the siren amplifier/relay module 17

Figure 3.3 Overview of Convergence Network Connections 19

Figure 3.4 Serial port locations 21

Figure 3.5 Configurable activation options for 10 A relays with active-low capability 22

Figure 3.6 Connection for 10 A solid-state auxiliary relays 23

Figure 3.7 Connection for 2 A solid-state relays 24

Figure 3.8 Connections for discretely wired SignalMaster 25

Figure 3.8 Switch operation for Inputs 1 to 4 26

Figure 3.9 Connections for discrete-wire SignalMaster 26

Figure 3.10 Connections for the Park Input circuit 27

Figure 3.11 Connections for two speakers 28

Figure 3.12 Connections for horn-ring transfer circuit 30

Figure 3.13 Connections for radio rebroadcast 31

Figure 3.14 Connections for the control head 32

Figure 3.15 Microphone connected to the control head 34

Figure 3.16 Negative ground connection for the control head 36

Figure 4.1 Default control head button for radio rebroadcast 37

Figure 4.2 Gain control for radio rebroadcast (siren amplifier/relay module) 38

Figure 4.3 Gain control for PA (amplifier/relay module) 38

Figure 4.4 Gain control for PA (control head) 39

Figure 5.1 Slots for mounting hardware 41

Figure 5.2 Bracket attached to back of control head 42

Contents

Figure 5.3 Brackets attached to control head and mounting surface42

Figure 6.1 LEDs and buttons associated with Program Mode settings.....44

Figure 6.2 Keep-Alive Timeout durations.....45

Figure 7.1 SSP2000B default configuration for control head.....48

Figure 7.2 SSP2000B control head and ignition timer inputs.....48

Figure 7.3 SSP3000B default configuration for control head.....49

Figure 7.4 SSP3000B control head and ignition timer inputs.....49

Figure 7.5 Default configuration for steering wheel switches wired to control head50

Figure 7.6 LED indicators and fuses on upper part of siren amplifier/relay module.....51

Figure 7.7 LED indicators on lower label of siren amplifier/relay module52

Figure 7.8 LED programming indicators on the control head53

Figure 8.1 Installing the control head labels54

Figure 8.2 Safety message card (left) and siren safety labels (right)55

Figure 10.1 Control head removed from mounting surface.....58

Figure 10.2 Control head removed from mounting brackets58

Figure 10.3 Slide switch removed from control head59

Figure 10.4 External parts assembly (SSP3000B shown).....61

Figure 10.5 Locking tabs on red insulator.....62

CHAPTER 1

Safety Messages for Installers and Operators

For your safety, read and understand this manual thoroughly before installing, operating, and servicing the SmartSiren Platinum siren amplifier/relay module. The safety messages presented in this chapter and throughout the manual are reminders to exercise extreme care at all times. In addition, read and understand the safety instructions to installers (doc. no. 256A692), and keep it close at hand for reference.

To download copies of this manual, go to www.fedsig.com or call the Federal Signal Service Department at 1-800-433-9132 (708-534-3400) 7 a.m. to 5 p.m., Monday through Friday (CT).

Safety Messages to Installers of Sound/Light Systems

⚠ WARNING

People's lives depend on your proper installation and servicing of Federal Signal products. It is important to read and follow all instructions shipped with this product. In addition, listed below are some other important safety instructions and precautions you should follow:

Before Installation

Qualifications

- To properly install an electronic siren, you must have a good understanding of automotive electrical procedures and systems, along with proficiency in the installation and service of safety warning equipment. Always refer to the vehicle's service manuals when performing equipment installations on a vehicle.

Sound Hazards

- Your hearing and the hearing of others, in or close to your emergency vehicle, could be damaged by loud sounds. This can occur from short exposures to very loud sounds, or from longer exposures to moderately loud sounds. For hearing conservation guidance, refer to federal, state, or local recommendations. OSHA Standard 1910.95 offers guidance on "Permissible Noise Exposure."
- All effective sirens and horns produce loud sounds (120 dB) that may cause permanent hearing loss. Always minimize your exposure to siren sound and wear hearing protection. Do not sound the siren indoors or in enclosed areas where you and others will be exposed to the sound.
- Federal Signal siren amplifier/relay modules and speakers are designed to work together as a system. Combining a siren and speaker from different manufacturers may reduce the warning effectiveness of the siren system and may damage the components. You should verify or test your

combination to make sure the system works together properly and meets federal, state and local standards or guidelines.

During Installation

- Do NOT get metal shavings inside the product. Metal shavings in the product can cause the system to fail. If drilling must be done near the unit, place an ESD approved cover over the unit to prevent metal shavings from entering the unit. Inspect the unit after mounting to be sure there are no shavings present in or near the unit.
- Do NOT connect this system to the vehicle battery until ALL other electrical connections are made, mounting of all components is complete, and you have verified that no shorts exist. If wiring is shorted to vehicle frame, high current conductors can cause hazardous sparks resulting in electrical fires or flying molten metal.
- Be sure the siren amplifier/relay module and speaker(s) in your installation have compatible wattage ratings.
- In order for the electronic siren to function properly, the ground connection must be made to the NEGATIVE battery terminal.
- Sound output will be severely reduced if any objects are in front of the speaker. If maximum sound output is required for your application, you should ensure that the front of the speaker is clear of any obstructions.
- Install the speaker(s) as far forward on the vehicle as possible, in a location which provides maximum signaling effectiveness and minimizes the sound reaching the vehicle's occupants. Refer to the National Institute of Justice guide 500-00 for further information.
- Mounting the speakers behind the grille will reduce the sound output and warning effectiveness of the siren system. Before mounting speakers behind the grille, make sure the vehicle operators are trained and understand that this type of installation is less effective for warning others.
- Sound propagation and warning effectiveness will be severely reduced if the speaker is not facing forward. Carefully follow the installation instructions and always install the speaker with the projector facing forward.
- Do NOT install the speaker(s) or route the speaker wires where they may interfere with the operation of airbag sensors.
- Installation of two speakers requires wiring speakers in phase.
- Never attempt to install aftermarket equipment, which connects to the vehicle wiring, without reviewing a vehicle wiring diagram available from the vehicle manufacturer. Insure that your installation will not affect vehicle operation and safety functions or circuits. Always check vehicle for proper operation after installation.
- Do NOT install equipment or route wiring or cord in the deployment path of an airbag.
- If a vehicle seat is temporarily removed, verify with the vehicle manufacturer if the seat needs to be recalibrated for proper airbag deployment.
- Locate the control head so the vehicle, controls, and microphone can be operated safely.

- When drilling into a vehicle structure, be sure that both sides of the surface are clear of anything that could be damaged.

After Installation

- After installation, test the siren and light system to ensure that it is operating properly.
- Test all vehicle functions, including horn operation, vehicle safety functions and vehicle light systems, to ensure proper operation. Ensure that installation has not affected vehicle operation or changed any vehicle safety function or circuit.
- After testing is complete, provide a copy of these instructions to the instructional staff and all operating personnel.
- File these instructions in a safe place and refer to them when maintaining or reinstalling the product.

Failure to follow all safety precautions and instructions may result in property damage, serious injury, or death.

RETAIN AND REFER TO THESE MESSAGES

Safety Messages to Operators of Sound/Light Systems

⚠ WARNING

People's lives depend on your safe operation of Federal Signal products. It is important to read and follow all instructions shipped with the products. In addition, listed below are some other important safety instructions and precautions you should follow:

- Do not attempt to activate or de-activate the light system control while driving in a hazardous situation.
- Although your warning system is operating properly, it may not be completely effective. People may not see or heed your warning signal. You must recognize this fact and continue driving cautiously.
- Also, situations may occur which obstruct your warning signal when natural and man-made objects are between your vehicle and others, such as raising your hood or trunk lid. If these situations occur, be especially careful.
- All effective sirens and horns produce loud sounds that may cause, in certain situations, permanent hearing loss. You and your passengers should consider taking appropriate safety precautions, such as wearing hearing protection.
- In order to be an effective warning device, this product produces bright light that can be hazardous to your eyesight when viewed at a close range. Do not stare directly into this lighting product at a close range or permanent damage to your eyesight may occur.
- It is important that you fully understand how to safely operate this warning system before use.
- You should only operate your vehicle and its light/sound system in accordance with your department's Standard Operating Procedures.

Chapter 1: Safety Messages for Installers and Operators

- If a selected function does not perform properly or if any of the lamps remain illuminated when the control is off, disconnect the power connector from the control unit and contact the nearest service center.
- At the start of your shift, you should ensure that the entire warning light system and the siren system is securely attached and operating properly.
- The effectiveness of an interior mounted warning light depends on the clarity, the tinting, and the angle of the glass it is being placed behind. Tinting, dirt, defects, and steeply angled glass reduce the light output of the warning light. This may reduce the effectiveness of the light as a warning signal. If your vehicle has dirty, tinted, or steeply angled glass, use extra caution when driving your vehicle or blocking the right of way with your vehicle.
- Suction cup mounting is for temporary applications only. The unit should be removed from the window and stored securely when not in use. Temperature changes and sunlight can cause suction cups to lose holding power. Periodically check the unit to be sure the suction cups have a firm grip on the mounting surface. An improperly secured light could fall off of the vehicle causing injury and damage.
- The holding power of magnetic mounting systems is dependent upon surface finish, surface flatness, and thickness of the steel mounting surface.

Therefore, to promote proper magnetic mounting:

- ✓ The mounting surface and magnets must be kept clean, dry, and free of foreign particles that prevent good surface contact.
- ✓ Ensure that the mounting surface is flat.
- ✓ A magnet mounting system should not be used on vehicles with vinyl tops.
- ✓ To prevent the light assembly from sliding on mounting surface, avoid quick acceleration and hard stops.

Failure to follow these precautions may result in property damage, serious injury, or death.

RETAIN AND REFER TO THESE MESSAGES

CHAPTER 2

An Overview of the SmartSiren Platinum

The SmartSiren Platinum siren amplifier/relay module is a full-featured, programmable electronic siren and light control system. State-of-the-art microprocessor technology is used to create a system with a small, compact control head and a siren amplifier/relay module that can be installed in the trunk, under the dashboard, or under the seat of any vehicle with a 12 V negative ground system.

The module provides the automatic, simultaneous light and siren activation required by some jurisdictions. A security shotgun timer is also provided to minimize the possibility of unauthorized shotgun release. The module has six easily accessible Convergence™ Network serial ports that connect the control head and any serially-controlled Federal Signal product. A variety of system features can be programmed with the Convergence Network Configuration Software from a computer via a crossover Ethernet cable that connects the control head. System features include flash patterns, siren tones, and momentary, push-on/push-off, or timed relay operation. Programming does not require disassembling or removing any hardware from the vehicle.

Siren, PA, and Speakers

The Smart Siren produces wail, yelp, priority, and hi-lo siren tones, as well as an air horn sound. The horn-ring transfer feature enables the driver to control siren tones by pressing the horn button. Public address is available with the Federal Signal microphone, which is included with the system. Radio rebroadcast is also available. The Model SSP3000B module can drive one or two 11-ohm impedance, 100 W speakers, and the Model SSP2000B module can drive one. Two speakers must always be connected in parallel and in phase.

Lightbars and SignalMaster™ Control

Compatible lightbars include full featured, serially-controlled Federal Signal Arjent® S2, Legend®, Valor™, and Integrity® as well as the SpectraLux™ ILS Series of interior-mounted lightbars. A full-featured SignalMaster™ controller is integrated into the system. In addition, flash rates and patterns, lightbar dimming, and other options can be programmed with the Convergence Network Configuration Software.

Programmable Solid-State Auxiliary Relays

The Model SSP3000B has 14 solid-state relays: ten 10 A high-low and four 3 A high.

The Model SSP2000B has 11 solid-state relays: one 10 A high-low, six 10 A high, and four 2 A high.

Programmable Input Circuits

Both models of the siren amplifier/relay modules have connections for four relay input circuits. Relay inputs 1 and 2 are active-low inputs that activate a switch when pulled to ground. Relay inputs 3 and 4 are active-high inputs that activate a switch when pulled to 12 Vdc battery voltage. The inputs are most commonly used for switches that send a signal to the siren amplifier/relay module when a condition in the vehicle changes. Changes may include the opening of a trunk or door, a rise in vehicle temperature, or the release of a gun lock.

The control head has connections for four active-low inputs that activate when pulled to ground. Similar to the relay circuits, they can be configured to operate with the Convergence system control head or with the configurable switches on the steering wheel of the Ford Police Interceptor.

LED Indicators and Visual Diagnostics (Model SSP3000B Only)

LEDs visible just below the surface of the siren amplifier/relay module indicate when power is supplied to the auxiliary outputs and if the module is transmitting and receiving data. LEDs also indicate when a signal is received by the four input circuits and if the lightbar is functioning. Externally mounted mini-blade fuses for the siren, horn-ring circuit, SignalMaster, and auxiliary relays have LEDs that glow when the fuse fails, making them easy to spot.

All buttons on the control head glow when the system is on. Pressed buttons turn bright to indicate that the function they control is active. LEDs under the SmartSiren logo mimic these active SignalMaster patterns: Left, Right, Center-Out, or Warn patterns 1 to 4. An LED glows over the position in which the slide switch is placed.

System Specifications

Input Voltage	11 Vdc to 16 Vdc
Polarity	Negative ground only
Operating Temperature Range	-40 °C to +65 °C (relays at full power) -40 °C to +80 °C (relays at 60 percent power)
Standby Current	Less than 0.2 A
Dimensions:	
Amplifier/relay module	
Height	4.22 in (10.72 cm)
Width	7.94 in (20.17 cm)
Length	6.81 in (17.30 cm)
Net Weight	5.40 lb (2.45 kg)
Control head	
Height	3.26 in (8.28 cm)
Width	1.62 in (4.11 cm)
Length	6.80 in (17.27 cm)
Net Weight	0.8 lb (0.36 kg)
Shipping Weight	10.0 lb (4.53 kg)

Siren Specifications

Speakers	SSP2000B: one 100 W, 11-ohm speaker SSP3000B: one or two 100 W, 11-ohm speakers
Operating Current (no lamps on)	9 A (nominal), (13.6 V battery, 11-ohm load at high power)
Frequency Range	725 to 1 600 Hz
Nominal Cycle Rate	Wail: 12 cycles per minute Yelp: 180 cycles per minute Priority: 370 cycles per minute High-Low: 60 cycles per minute
Nominal Voltage Output	64 V peak-to-peak (siren tones)
Audio Response	300 Hz to 3,000 Hz \pm 3 dB
Audio Power	45 W in PA Mode (typical with 1.4 V peak-to-peak input)
Harmonic Distortion	Less than 10 percent from 5 to 45 W
Input Impedance (PA)	4,000 ohms (nominal)
Siren Tone Compliances	SAE J1849 JUL89

SignalMaster Specifications (Model SSP3000B only)

Fuse	20 A (halogen or LED)
Output Drive Capability (Total)	Eight lamps at 27 W each
Normal Flash Rate	
Directional and Warn	Approximately 35 patterns per minute
Fast Flash Rate	
Directional and Warn	Approximately 45 patterns per minute

Relay Specifications

Model SSP3000B Fuse Capability	AUX 1 to 8: 10 A (high) AUX 9 and 10: 10 A (high-low) AUX 11 to 14: 2 A high
Model SSP2000B Fuse Capability	AUX 1 to 6: 10 A (high) AUX 10: 10 A (high-low) AUX 11 to 14: 2 A (high)
Flash Rates	75 flashes per minute 90 flashes per minute 120 flashes per minute 200 flashes per minute 300 flashes per minute

SmartSiren Platinum Kit Contents

Table 2.1 (Model SSP2000B) and 2.2 (SSP3000B) lists the parts included with the SmartSiren Platinum kit. After unpacking the kit, examine it for damage that may have occurred in transit. If the product has been damaged, file a claim immediately with the carrier stating the extent of damage. Carefully check all envelopes, shipping labels, and tags before removing or destroying them. Ensure all parts in the packing list are included in the shipment. If any parts are missing, call Federal Signal Customer Support at 1-800-264-3578, 7 a.m. to 5 p.m., Monday through Friday, Central Time.

Table 2.1 SSP2000B kit contents

Qty.	Description	Part Number
1	SSP2000B Control Head	853600632-SSP2K
1	SSP2000B Siren Amplifier/Relay Module	853600629-04
1	Cable Assy., RS485, 25 ft	1751357-02
1	Cable Assy., Control	17500307
1	Cable Assy., Auxiliary Relay	1751541
1	Cable Assy., SignalMaster and Inputs	1751542-NY
1	Cable Assy.	17500308
2	Bracket, Mounting, Control Head	85361065
2	Screw, Mach. Pan Head, #6-32	7000A404-05
2	Screw, Cap, Hex Head, 1/4"-20	7002A000-12
2	Screw, Pan Head, #10, Thread-Forming	7011A047-08
2	Lock Washer, Split, #6	7074A001
2	Lock Washer, Ext, Tooth, 1/4"	7075A007
1	Keyhead Legends, Scored Sheet	8572294
1	Microphone with Modular Plug	256B577-03
1	Fuse, 5 A, Mini Blade	148181-03
7	Fuse, 10 A, Mini Blade	148181-05
1	Fuse, 20 A, Mini Blade	148181
1	Quick Reference Guide	2562503
1	Card, Safety Instructions	256B691
1	Instruction Sheet, Operators Safety Messages	256A692
1	Label, Warning, Siren/Speaker	1612339

Table 2.2 SSP3000B kit contents

Qty.	Description	Part Number
1	SSP3000B Control Head	853600632
1	SSP3000B Siren Amplifier/Relay Module	853600629
1	Cable Assy., RS485, 25 ft	1751357-02
1	Cable Assy., Control	17500307
1	Cable Assy., Auxiliary Relay	1751541
1	Cable Assy., RJ45 Ethernet Crossover	1751532
1	Cable Assy., SignalMaster and Inputs	1751542-01
1	Cable Assy.	17500308
1	Cable Assy., RJ45, Ethernet Crossover	1751532
2	Bracket, Mounting, Control Head	85361065
2	Screw, Mach. Pan Head, #6-32	7000A404-05
2	Screw, Cap, Hex Head, 1/4"-20	7002A000-12
2	Screw, Pan Head, #10, Thread-Forming	7011A047-08
2	Lock Washer, Split, #6	7074A001
2	Lock Washer, Ext, Tooth, 1/4"	7075A007
1	Keyhead Legends, Scored Sheet	8572294
1	Microphone with Modular Plug	256B577-03
1	Fuse, 5 A, Mini Blade, LED Indicator	148210-04
7	Fuse, 10 A, Mini Blade, LED Indicator	148210-06
1	Fuse, 20 A, Mini Blade, LED Indicator	148210-08
1	Quick Connect Guide	25600152
1	Quick Reference Guide	2562503
1	Card, Safety Instructions	256B691
1	Instruction Sheet, Operators Safety Messages	256A692
1	Label, Warning, Siren/Speaker	1612339

CHAPTER 3

Connecting the Convergence Network

Before permanently installing the SmartSiren Platinum system, plan all wire routings and select the mounting locations for the siren amplifier/relay module and control head. Also read and understand all instructions included with related equipment before installing it.

Selecting Mounting Locations

When fastened to the back of the control head, the mounting bracket covers the wiring connectors and a supplemental control for the gain or volume of the radio rebroadcast feature. To facilitate the installation of the SmartSiren Platinum system, select mounting locations for the control head and the siren amplifier/relay module before permanently mounting them in the vehicle. After completing the wiring described in this chapter, refer to the instructions for mounting the control head and the siren amplifier/relay module in Chapter 5 on page 40.

⚠ WARNING

AIRBAG DEPLOYMENT: Do not install equipment or route wiring in the deployment path of an airbag. Failure to observe this warning will reduce the effectiveness of the airbag or potentially dislodge the equipment, causing serious injury or death.

⚠ WARNING

SEAT REMOVAL PRECAUTION: If a vehicle seat is temporarily removed, verify with the vehicle manufacturer if the seat needs to be recalibrated for proper airbag deployment.

NOTICE

UNIT REQUIRES AIR FLOW (SSP3000B ONLY): The siren amplifier/relay module is cooled by an internal fan. Do not install it in areas where the air flow is restricted. Do not mount the unit near a heater duct or under the hood.

NOTICE

MODULE IS NOT WATERPROOF: The housing of the siren amplifier/relay module is NOT waterproof. The module must be mounted in a location that is sheltered from falling rain, snow, standing water, etc.

For the control head, select a mounting location that allows the vehicle, controls, and microphone to be operated safely under all driving conditions. To identify safe mounting areas for equipment inside the vehicle, consult the vehicle manufacturer's guidelines. To avoid driver distraction and unreliable switch activation, the mounting location must not allow any movement of the control head. Do not select a headded surface for the mounting location of the control head. For the siren amplifier/relay module, suggested mounting locations are under the dash, under the front seat, or in the trunk under the rear deck near the rear-seat speakers. Wiring connectors are located on the back of the siren amplifier/relay module. Terminals for the ground and power connections are located on each side toward the rear.

IMPORTANT: To maintain the reliability of the Model SSP3000B amplifier/relay module, which is cooled by a fan, ensure that there is enough room for the flow of air.

Figure 3.1 Dimensions of the control head

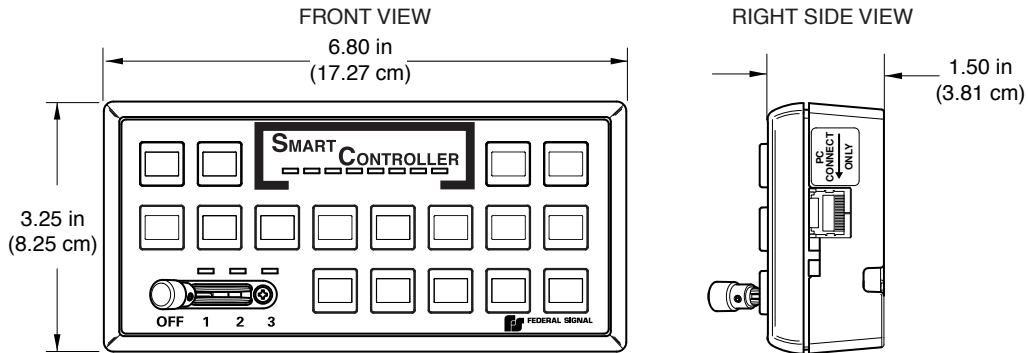
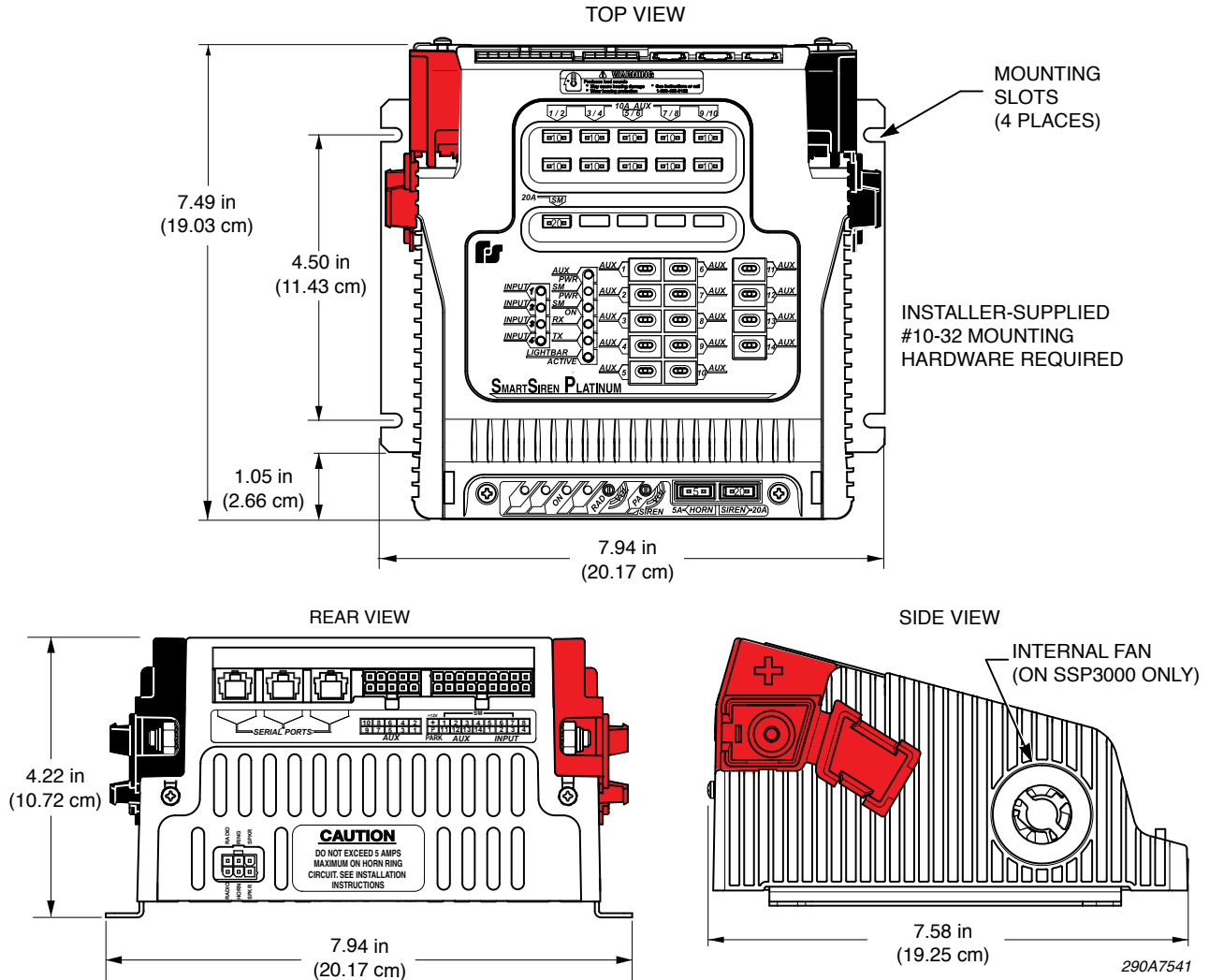

Figure 3.2 Dimensions of the siren amplifier/relay module



Overview of the Convergence Network Connections

The Convergence Network system has these types of connections via cables and locking connectors included with the kit (see Figure 3.3):

Connections for the siren amplifier/relay module:

- ◆ Three “plug and play” serial ports that communicate on the Federal Signal Convergence network with the control head, compatible lightbars, and the Federal Signal Model 660100 Relay Module/Two-Channel Flasher.
- ◆ Seven to ten 10 A auxiliary solid-state relays (cable assembly 1751541)
- ◆ Four low-current auxiliary solid-state relays and a Park Input circuit (cable assembly 1751542-01 or 1751542-NY)
- ◆ SignalMaster directional warning lights (cable assembly 1751542-01, SSP3000B only)
- ◆ Four auxiliary relay inputs (cable assembly 1751542-01 or 1751542-NY)
- ◆ Speakers and a horn ring circuit (cable assembly 17500307)
- ◆ Power terminals for negative ground and positive 12 Vdc

Connections for the control head:

- ◆ Four active-low input circuits that activate when pulled to ground. They can be configured to operate with the SSP3000B system control head or with the switches on the steering wheel of the Ford Police Interceptor.
- ◆ Connections to the siren for battery ground (-GND) and +12 Vdc switched by ignition
- ◆ Connection for the Federal Signal public address microphone (P/N 258B577-03)
- ◆ Convergence Network 25-foot cable that connects the control head to the siren amplifier (1751532)
- ◆ Optional ignition input to run long timers

For installation details, see pages 20 through 36.

For instructions on configuring the operation of the devices connected through the Convergence Network, see the “Convergence Configuration Software Manual” P/N 2562418.

Figure 3.3 Overview of Convergence Network Connections

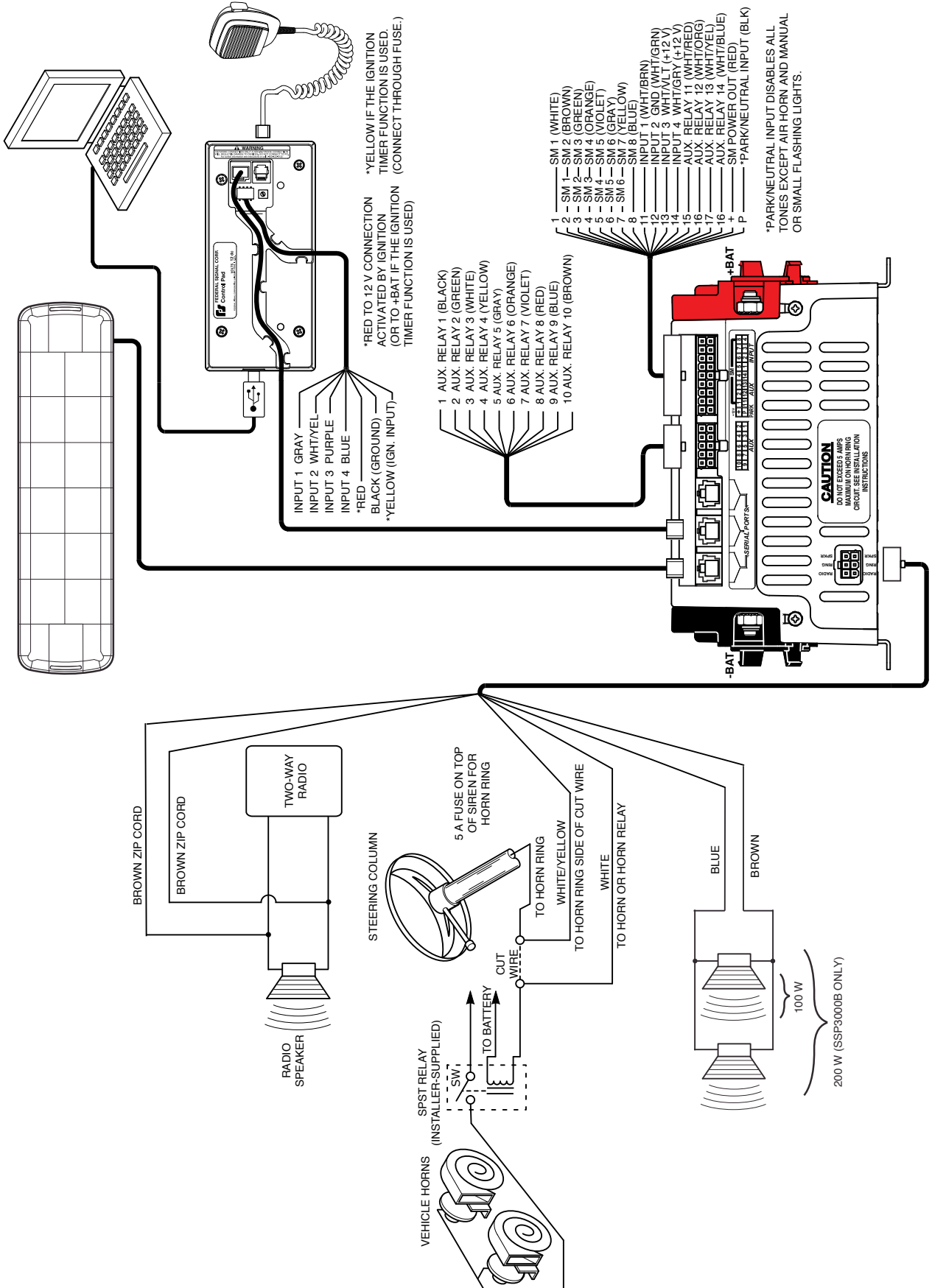

Preparing for the Convergence Network Installation

⚠ WARNING

HIGH CURRENT ARCING: Do not connect this system to the vehicle battery until ALL other electrical connections are made and you have verified that no shorts exist. High current conductors can cause hazardous sparks or burning wire resulting in electrical fires.

NOTICE

DRILLING PRECAUTIONS: When drilling holes, check the area into which you are drilling to be sure that you do not damage vehicle components while drilling. All drilled holes should be deburred and all sharp edges should be smoothed. All wiring routings going through drilled holes should be protected by a grommet or convolute/split loom tubing.

To prepare the vehicle for connecting the Convergence Network system:

1. After planning where to route the wires and cables for the system components—such as Federal Signal warning lights, directional lights, and speakers—drill the holes for the wiring. Smooth, deburr, and insert a grommet in the holes.
2. Mount the system components according to the instructions included with each product.

The next sections describe how to connect and wire each system component to the siren amplifier/relay module.

Connecting the Convergence Network

There are three network ports on the upper left rear corner of the siren amplifier/relay module. These ports connect Federal Signal network devices through RS-485 communication cables.

Network devices include:

- ◆ The system control head, which must be connected to a serial port on the siren amplifier/relay module. Use the 25-foot FS Convergence Network cable (P/N 1751357-02) to connect the control head to the module.
- ◆ Exterior-mounted, full-size lightbars, such as the Arjent[®] S2, Legend[®], Valor[™], and Integrity[®]. Configurable options include flash patterns and functions, such as dimming, takedowns, and alley lights.
- ◆ ILS System lightbars that include three models of single-level LED lightbars — Front ILS, Rear Lower ILS, and Rear Upper ILS — that mount on the inside of a vehicle windshield. Configurable options include flash patterns and functions, such as dimming, takedowns, and alley lights.

Figure 3.4 on page 21 shows the network connections on the back of the siren amplifier/relay module. For instructions on mounting network devices, refer to the instructions included with the products.

To connect the devices:

1. Carefully route the cables from the network devices through the vehicle to the connectors on the siren amplifier/relay module.
2. To provide strain relief, secure the cables with installer-supplied clamps and hold-downs.
3. Insert the modular connector at the end of each cable into the appropriate connector.

NOTE: The 25-foot FS Convergence Network cable must be connected between the control head and one of the three serial ports (Figure 3.3 on page 19).

Figure 3.4 Serial port locations

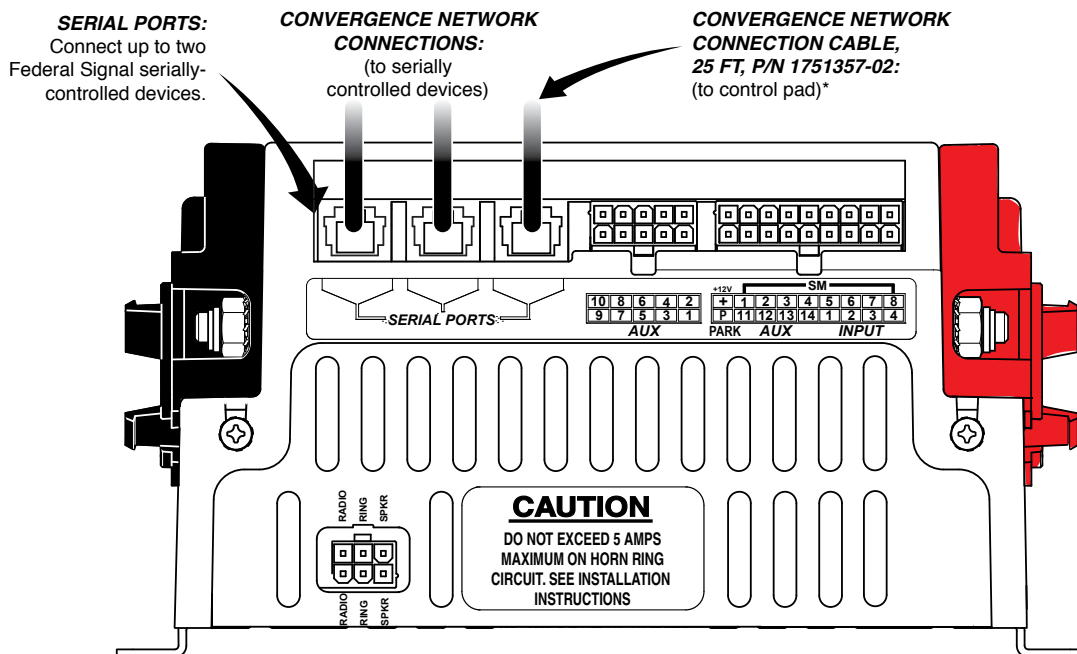

Connections for 10 A Auxiliary Relays

Cable assembly P/N 1751541 has 18-inch leads for eight to ten (depending on the model) 10 A solid state relays with these configurable options:

- ◆ Eight +12 Vdc out (active high)
- ◆ Two +12 Vdc out (active high) or negative (–) ground out (active low)
- ◆ Steady-on or one of five flash rates for small flashing lights.
- ◆ Synchronized or alternating flashing for two or more lights.
- ◆ Open-off or inverse-off operation.

NOTE: The Model SSP2000B has one high-low 10 A relay. The rest are +12 Vdc only relays.

Table 3.1 Descriptions of configurable activation options for 10 A relays

Configured Activation	Description
Active High	The relay supplies +12 Vdc during the “on” state.
Active Low	The relay supplies ground during the “on” state.
Open Off	The relay is open during the “off” state, a condition similar to an open electromechanical relay.
Inverse Off	The NC relay alternates from its former polarity to the other each time it is in the “off” state.

Figure 3.5 Configurable activation options for 10 A relays with active-low capability

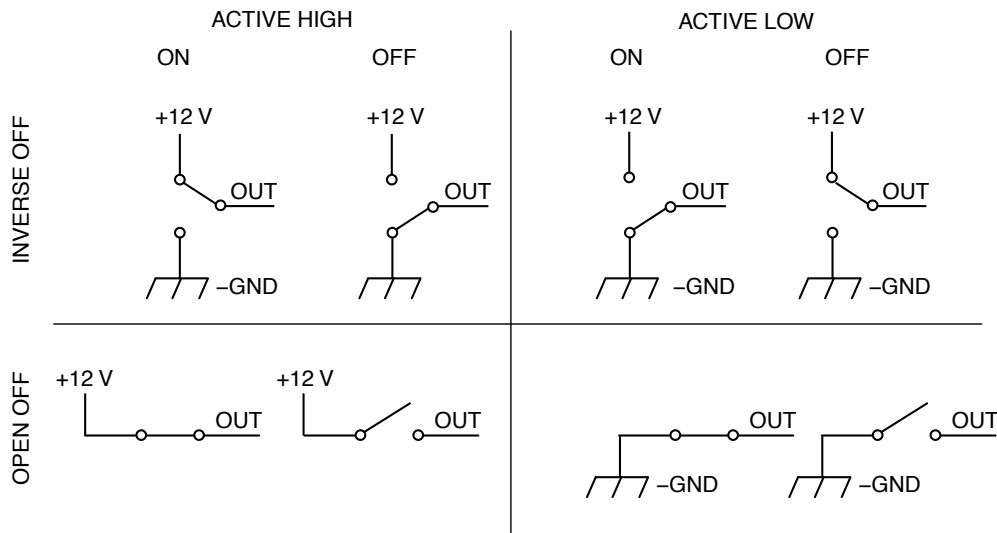
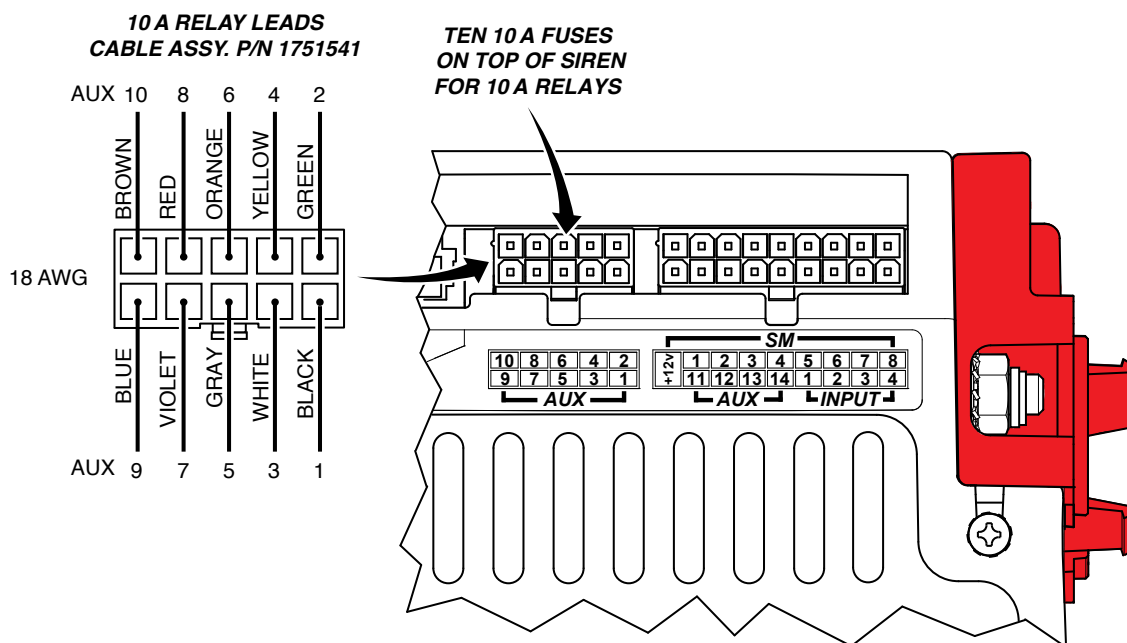

Figure 3.6 on page 23 shows the connectors for the 10 A relay cable assembly on the back of the amplifier/relay module. The relays are fused on top of the module with 10 A mini-blade fuses. Extend wiring with 18 AWG leads or thicker. Insulate spliced leads with twist-on wire connectors. Fold and seal unused leads.

Figure 3.6 Connection for 10 A solid-state auxiliary relays



Connections for Low-Current Auxiliary Relays

Cable assemblies 1751542-NY (SSP2000B) and 1751542-01 (SSP3000B) includes 18-inch, 18 AWG leads for four solid-state relays. The relays are 12 Vdc out only (active high) with these software-configurable options:

- ◆ Steady-on lighting or one of five flash rates for small flashing lights.
- ◆ Synchronized or alternating flashing for two or more small flashing lights.

Figure 3.7 on page 24 shows the connectors for the relay cable assembly on the back of the siren amplifier/relay module. The relays are protected inside the module by electronic short-circuit detection circuits.

Extend wiring with 18 AWG leads or thicker. Insulate spliced leads with twist-on wire connectors. Fold and seal unused leads.

Table 3.2 Configurable activation options for 2 A solid-state relays

Configured Activation	Description	Diagram
Active High	The relay supplies +12 Vdc during the “on” state.	
Open Off	The NC relay is open during the “off” state, a condition similar to an open electromechanical relay.	

Figure 3.7 Connection for 2 A solid-state relays

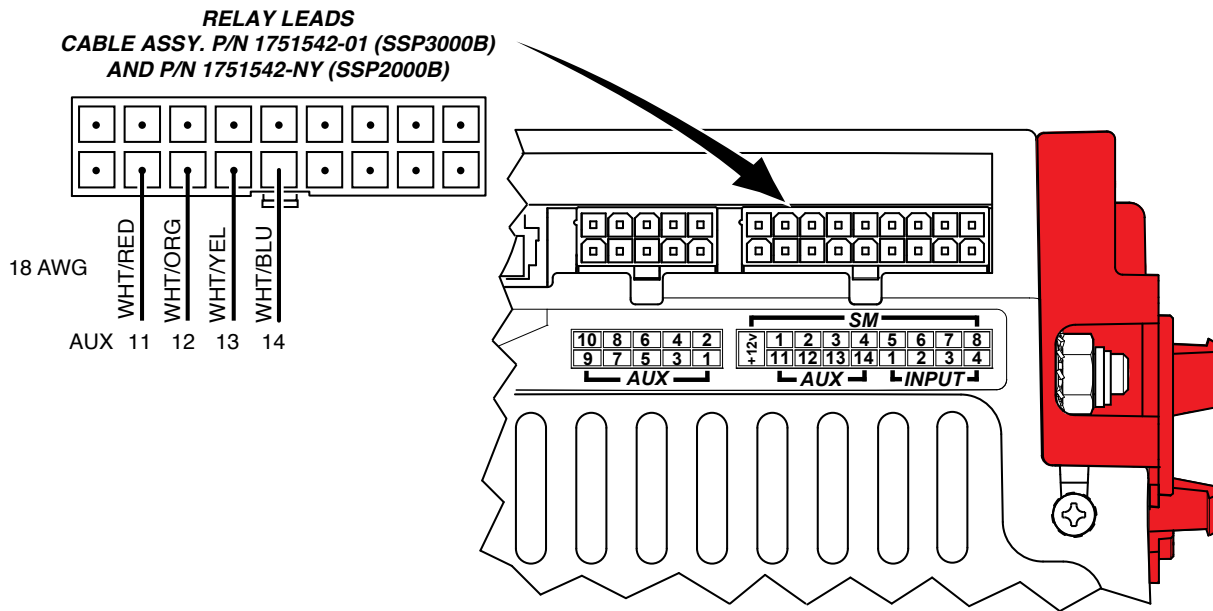

Connections for the Latitude SignalMaster

The SSP3000B and SSP2000B both support controlling the Latitude SignalMaster through a combination of high-current and low-current relays. The relays used for Latitude are shown in the table below and cannot be changed to other available relays. Enabling these relays to control the Latitude is done through the Convergence Configuration Software on the SignalMaster buttons.

For more information on the Latitude see installation manual No. 25500085.

Table 3.3 Latitude SignalMaster control wires

SSP3000B	SSP2000B	Control Wires
Relay 8	Relay 6	Red
Relay 13	Relay 13	Green
Relay 14	Relay 14	White
Ground	Ground	Black

Connections for Relay Inputs 1 to 4

Cable assemblies P/N 1751542-01 and P/N 1751542-NY include 18-inch, 20 AWG wires for four relay circuit inputs. Figure 3.9 shows the connectors for the four input leads on the back of the amplifier/ relay module. **Inputs 1 to 4** are most commonly used for circuits that send a signal to the SSP3000B system when a condition in the vehicle changes. Changes in conditions may include the opening of a trunk or door, a rise in vehicle temperature, or the release of a gun lock. The inputs are often used for police vehicle anti-theft devices, intrusion alarms, and temperature monitoring systems for K9 vehicles.

Input 1 and 2 are active-low inputs that activate when the input pin is pulled to ground. **Input 3 and 4** are active high inputs that activate when the input pin is pulled to +12 Vdc battery voltage (Figure 3.8).

Figure 3.8 Switch operation for Inputs 1 to 4

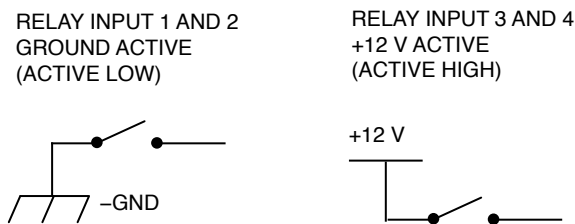

Software-configurable options include siren activation or siren mute, timer settings, and switch operation. Extend wiring with 20 AWG leads or thicker. Insulate spliced leads with twist-on wire connectors. Fold and seal unused leads.

NOTE: If using a Federal Signal lightbar equipped with an ambient light sensor, **Input 1** is used to control functions activated by the ambient light sensor. To avoid a malfunction, do not connect anything to the input wire for **Input 1** when using a lightbar equipped with an ambient light sensor. To enable lightbar dimming with the ambient light sensor, enable Auto Dim on **Relay Input 1** in the Convergence Configuration Software.

Figure 3.9 Connections for discrete-wire SignalMaster

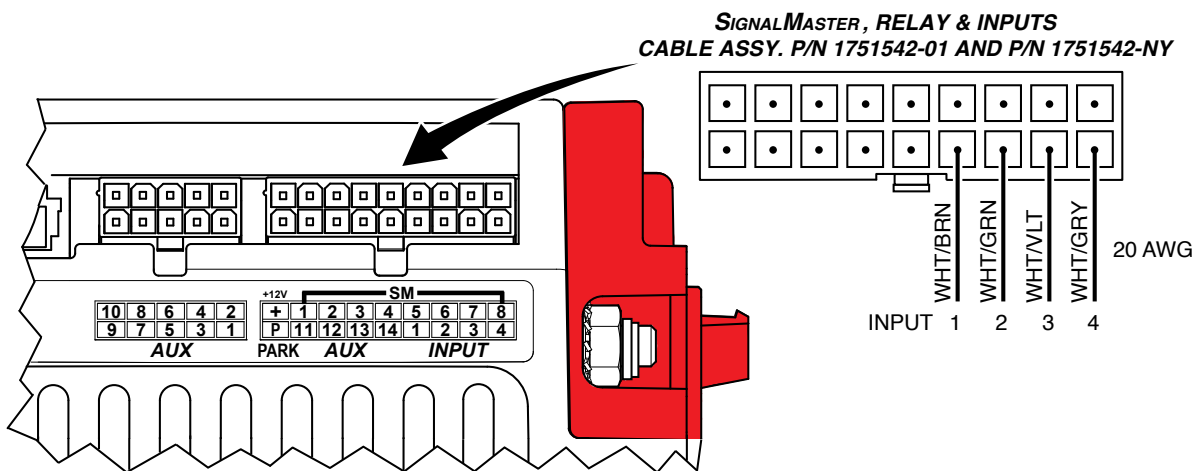

Connections for the Ambient Light Sensor

The SSP3000B and SSP2000B both support Federal Signal lightbars equipped with an ambient light sensor. The software uses **Input 1** to activate functions when the lightbar senses low light. No extra connections are needed to support this feature. Simply do not connect anything to Input 1, and make any programming changes you want active during low light on the Input 1 button of the Convergence Configuration Software.

Park Input (Cable Assembly 1751542-01 or 1752542-NY)

The **Park Input** circuit sends a signal to the siren amplifier/relay module to mute all siren functions except Air Horn and Manual when the vehicle transmission is shifted into park or neutral. The circuit can detect a +12 V signal or a –GND signal.

IMPORTANT: The operation of the Park Input circuit can be configured as active high or active low. The Park Input function is configured through the control head. For instructions, see “Selecting Active-High Activation of the Park Input Circuit” on page 45.

The **Siren Mute** option is configured with the Convergence Configuration Software.

To wire the Park Input option:

1. Connect the black Park Input wire from the siren to the electrical circuit that provides +12 V or –GND when the vehicle transmission is in park (Figure 3.10).
2. Extend wiring with 18 AWG leads or thicker.
3. Insulate spliced leads with twist-on wire connectors. Fold and seal unused leads. Use wire ties and hold-downs for strain relief.

Figure 3.10 Connections for the Park Input circuit

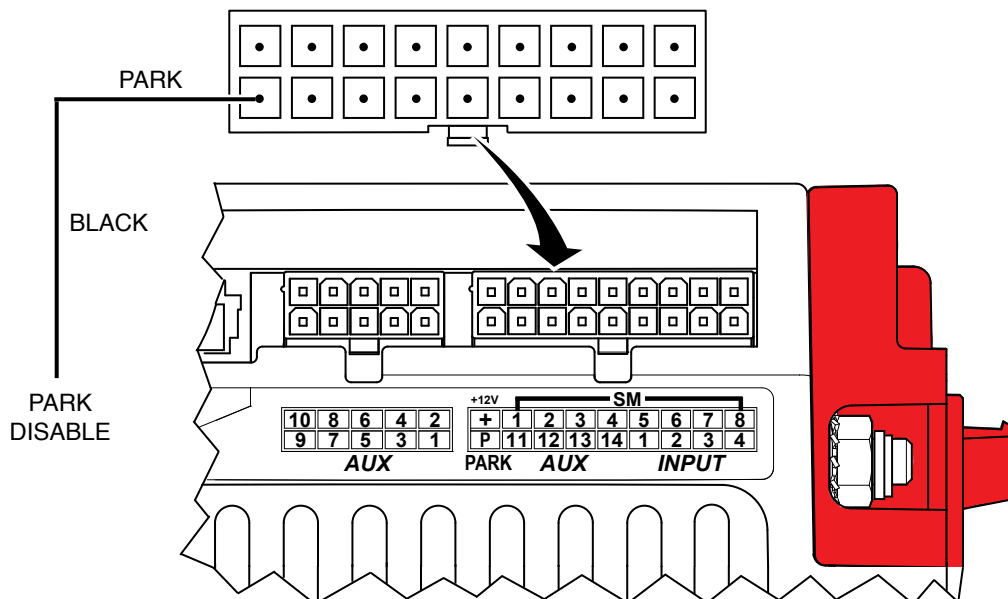

Speaker Connections (Cable Assembly P/N 17500307)

The SSP2000B siren amplifier operates with one 11 ohm impedance, 100 W speaker. The SSP3000B is designed to operate with one or two 11 ohm impedance, 100 W speakers. Software-configurable options include a variety of siren tones, horn ring transfer, slide switch operation, and siren activation or siren mute.

NOTICE

WIRING PRECAUTION: Do not connect the brown zip cord wires to the speaker. Failure to follow this precaution may damage the speaker system.

To connect one speaker:

1. Use 18 AWG wire to connect one speaker lead to the blue lead from the cable assembly.
2. Use 18 AWG wire to connect the other speaker lead to the single brown lead from the cable assembly.

To connect two speakers (SSP3000B only):

Connect the speakers in parallel and in phase to the blue lead and the single brown lead from the cable assembly. When finished, insulate spliced leads with twist-on wire connectors. Fold and seal unused leads.

Figure 3.11 Connections for two speakers

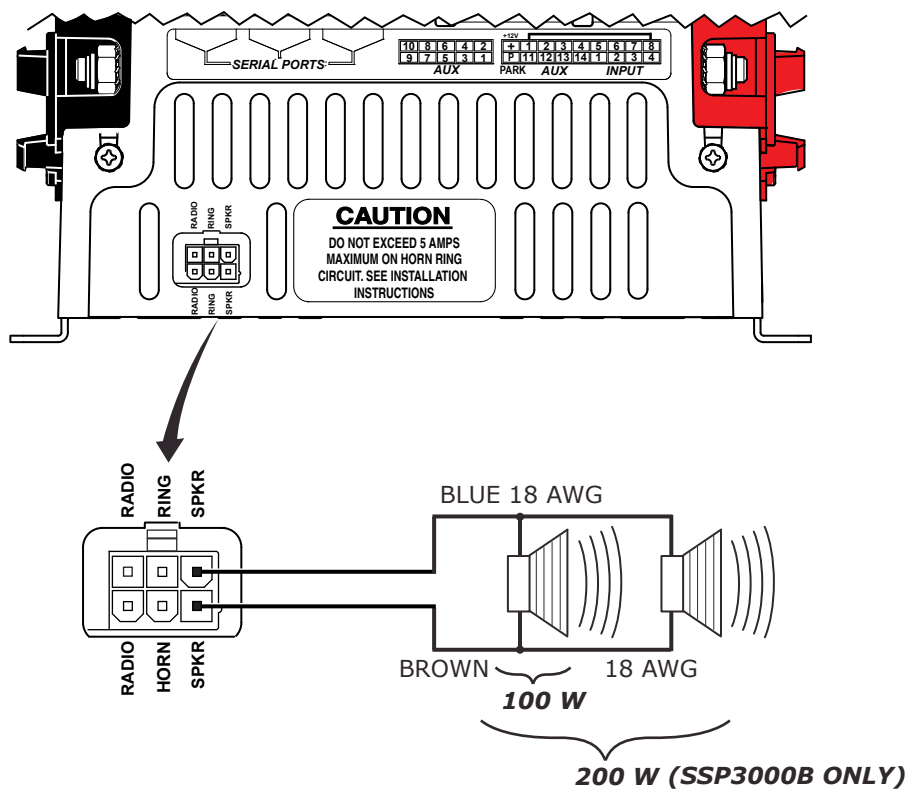

Horn Ring Transfer (Cable Assembly 17500307)

The default setting for the slide switch transfers the horn-ring activation of the siren in **Slide Switch 2** and **3**. In **Slide Switch 2**, a press of the horn button activates the Manual tone. In **Slide Switch 3**, each press of the horn button cycles through a siren function, such as tones or air horn, assigned to horn-ring transfer via the Convergence Configuration Software. In addition, the default configuration for **Slide Switch 3** is **Siren Dependent Enabled**, which restricts siren activation to the slide switch position you select. For example, if you press a button that is assigned a siren tone, the tone only activates when you place the slide switch in the position that is **Siren Dependent Enabled**.

NOTE: The horn ring circuit can be programmed as active high or active low as described in Chapter 6.

To enable horn-ring control of siren tones, obtain a SPST relay of enough contact-current capacity to activate the vehicle horn:

1. Cut the wire that connects the switch for the vehicle horn ring to the horn or horn relay (Figure 3.12 on page 30).
2. Splice the white/yellow wire from the power cable to the horn ring side of the wire that you cut in step 1.

NOTICE

DETERMINE CURRENT FOR HORN—*The horn ring transfer circuit of the siren can switch a maximum of 5 A. Some vehicles do not have a horn relay and consequently will draw more than 5 A when the vehicle horn is activated. Consult your vehicle service manual or a qualified mechanic to determine the current required to activate the horn. If it is less than 5 A, perform step 3. If it is greater than 5 A, perform steps 4 through 9.*

3. Splice the white wire from the power cable to the horn side of the cut wire.
4. Mount the SPST relay in a suitable location.
5. Connect the horn side of the wire cut in step 1 to the relay-contact terminal.
6. Determine the “sense” of the vehicle’s horn ring activation circuit. Does the horn circuit require a switched positive (active-low) voltage or switched ground (active-high) for activation?
7. Connect the switched relay-contact terminal to the positive or negative potential you determined in step 6.
8. Connect the white wire from the power cable to one end of the relay coil.
9. Connect the other end of the relay coil to the opposite potential of that connected to the switched relay contact terminal in step 7.
10. Insulate the spliced leads with twist-on wire connectors. Fold and seal unused leads.

Figure 3.12 Connections for horn-ring transfer circuit

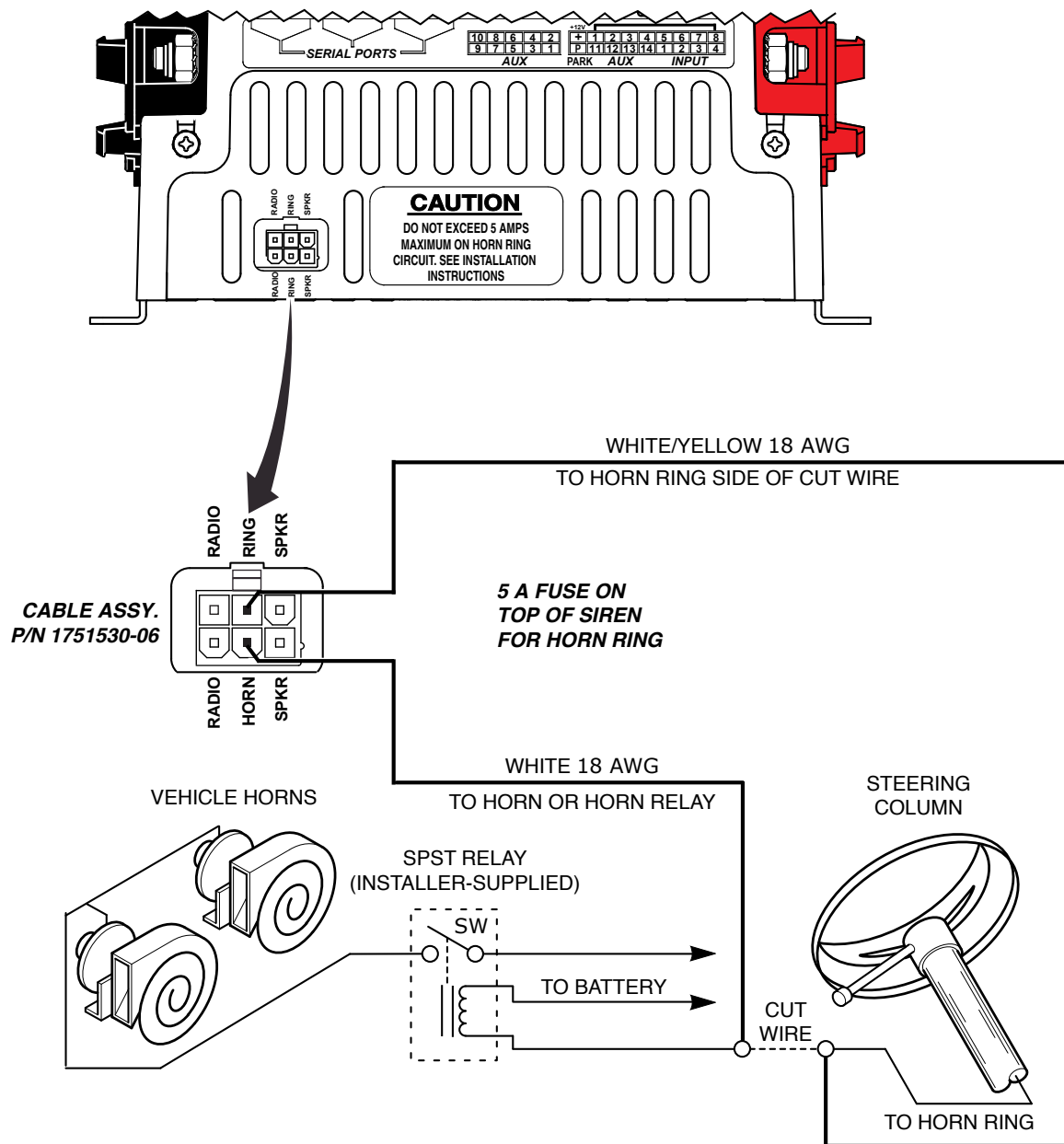

Radio Rebroadcast (Cable Assembly 17500307)

To allow incoming two-way radio messages to be amplified by the siren amplifier/relay module and rebroadcast over the siren speakers, connect the brown 18 AWG two-conductor zip-cord across the speaker of the two-way radio (Figure 3.13). Insulate spliced leads with twist-on wire connectors. Fold and seal unused leads. For instructions on adjusting the gain, see “Setting the Gain for Radio Rebroadcast” on page 37.

Figure 3.13 Connections for radio rebroadcast

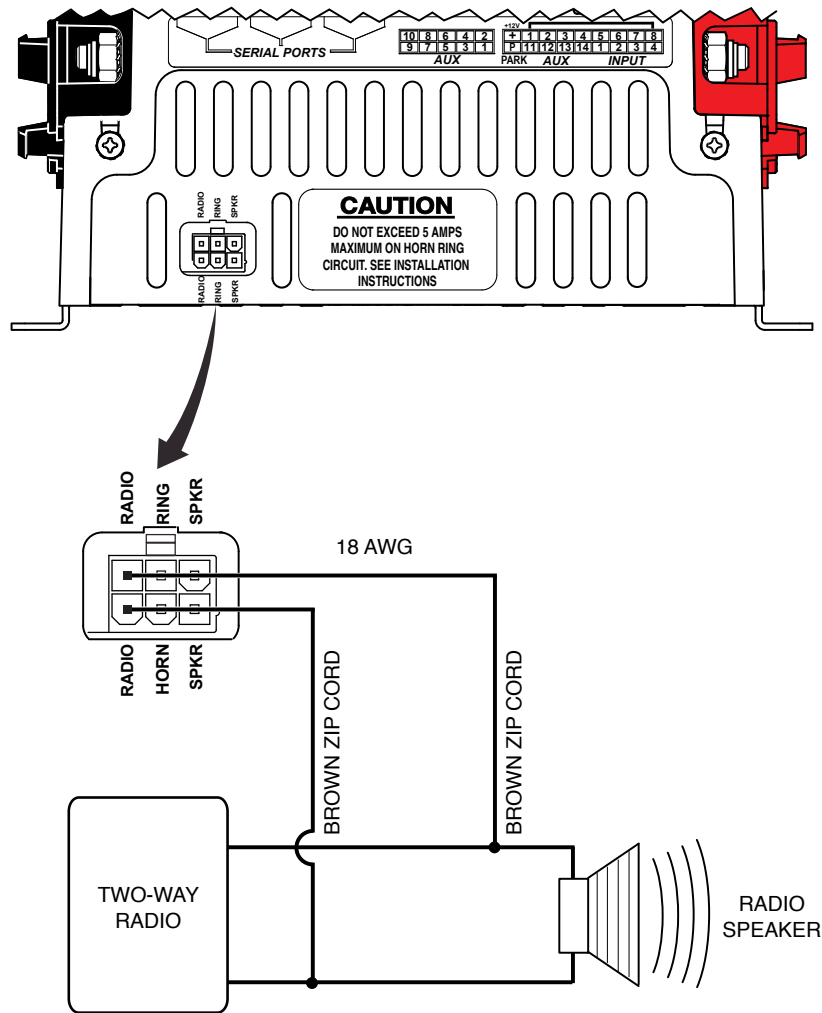

Connecting the Control Head

In addition to the connection through the 25-foot Convergence Network cable, the control head has:

- ◆ Connections for four active-low input circuits that activate when pulled to ground (17500308)
- ◆ Connections to the siren for battery ground (–GND) and +12 Vdc switched by ignition or battery +12Vdc for ignition timers (17500308)
- ◆ Connection for optional ignition sense (+12 Vdc) for ignition timers (17500308)
- ◆ Connection for the Federal Signal public address microphone (258B577-03)
- ◆ 25-foot cable that connects the control head to the siren amplifier (1751537-02)

The next sections describe how to connect the control head to the network.

Connecting the Active-Low Input Circuits (Cable Assembly 17500308)

Cable assembly 17500308 includes 18-inch, 22 AWG wires for four active-low circuit inputs. Figure 3.14 shows the connectors for the four input leads on the back of the control head. Similar to the siren relay circuits, **Inputs 1 to 4** are most commonly used for circuits that send a signal to the Convergence Network system when a condition in the vehicle changes. Changes in conditions may include the opening of a trunk or door, a rise in vehicle temperature, or the release of a gun lock. The inputs are often used for police vehicle anti-theft devices, intrusion alarms, and temperature monitoring systems for K9 vehicles.

Figure 3.14 Connections for the control head

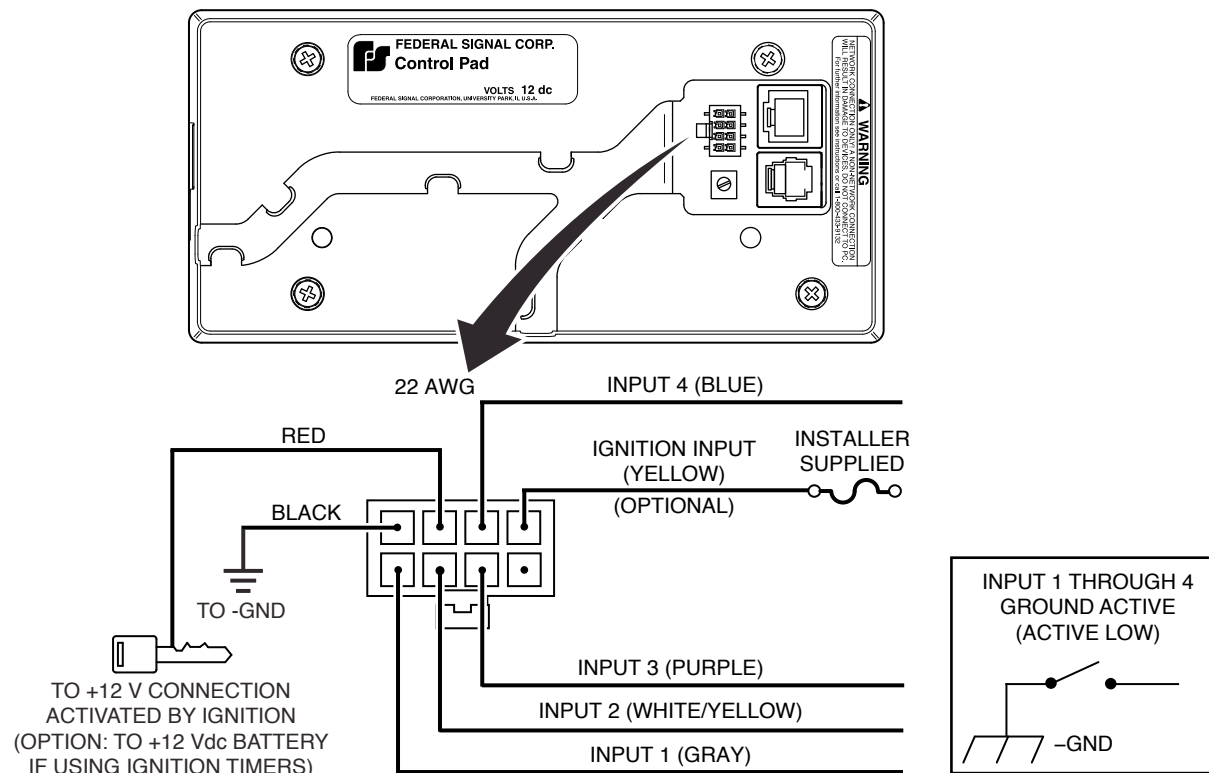

Each input circuit can be programmed to activate with an installer-supplied switch having a current capacity of 100 mA , with the SSP3000B control head, or with the two-way switches on the steering wheel of the Ford Police Interceptor. For the location of the vehicle 14-way connector for the ground-sourcing outputs, refer to the Ford Police Interceptor Modifier Manual.

For programming information, see the Convergence Configuration Software Manual. For a chart showing the default configurations for the control head and for the steering wheel switches connected to the four low-input circuits, see page 44.

Connecting Ignition Power to the Control Head (without Ignition Timer)

The red and black leads from the control head supply power to the SSP3000B system when the vehicle ignition key is in the ignition (start) position (Figure 3.14 on page 32).

To connect the control head to ignition power:

1. Use a multimeter to determine which source provides power when the vehicle key is in the ignition position.
2. Connect the red lead from the control head to the switched side of the vehicle ignition harness. **Do not splice the red lead to the power leads for accessories.** Extend the lead with 22 AWG leads or thicker.
3. Connect the black lead from the control head to negative ground. Extend the lead with 22 AWG leads or thicker.
4. Insulate spliced leads with twist-on wire connectors. Fold and seal unused leads. Use wire ties and hold-downs for strain relief.

Connecting Power to the Control Head (with Ignition Timer)

The SmartSiren Platinum system has an optional ignition timer function (Keep-Alive Timeout) that enables public safety personnel to use mobile equipment for a set period of time with the engine turned off. The function insures that the battery has enough power to start the vehicle. Mobile equipment includes any device that is charged from the vehicle battery or requires power after ignition is removed, such as flashlights, laptops, radios, and digital recorders.

Four independent time delays are available ranging from immediately off to four hours on. The ignition timer is not enabled by default and is programmed with the Convergence Network Configuration software using the amplifier input buttons. Do not connect anything to the amplifier input wires selected for the ignition timer.

The red and black leads from the control head supply power from the vehicle battery to the SmartSiren Platinum System. The yellow ignition wire activates the system when the ignition key is in the start position.

Additionally, the ignition timer can keep alive the SmartSiren Platinum and other Convergence Network devices for a set amount of time after ignition is removed. The control head ignition Timeout is set through the control head. For instructions, see “Configuring Keep-Alive Timeout” on page 45.

To connect the control head to ignition power:

1. Use a multimeter to determine which source provides power when the vehicle key is in the ignition position.
2. Connect the yellow lead from the control head to the switched side of the vehicle ignition harness. Extend the lead with 22 AWG leads or thicker.
3. Connect the red lead from the control head to a constant +12 Vdc from the battery. Do not splice the red and yellow leads to the power leads for accessories. Extend the lead with 22 AWG leads or thicker.
4. Connect the black lead from the control head to negative ground. Extend the lead with 22 AWG leads or thicker.
5. Insulate spliced leads with twist-on wire connectors. Fold and seal unused leads. Use wire ties and hold-downs for strain relief.

Connecting the Federal Signal Microphone (P/N 258B8577-03)

The microphone provides high quality voice reproduction in for public address over the siren speakers. The microphone push-to-talk switch overrides all siren functions, except radio rebroadcast, for instant PA use. The microphone connection is not required for the siren to operate properly.

To attach the microphone cable to the control head, insert the modular telephone-type plug in the microphone jack until it locks. For instructions on adjusting the PA volume, see “Setting the Gain for Public Address (Microphone Volume)” on page 38.

Figure 3.15 Microphone connected to the control head

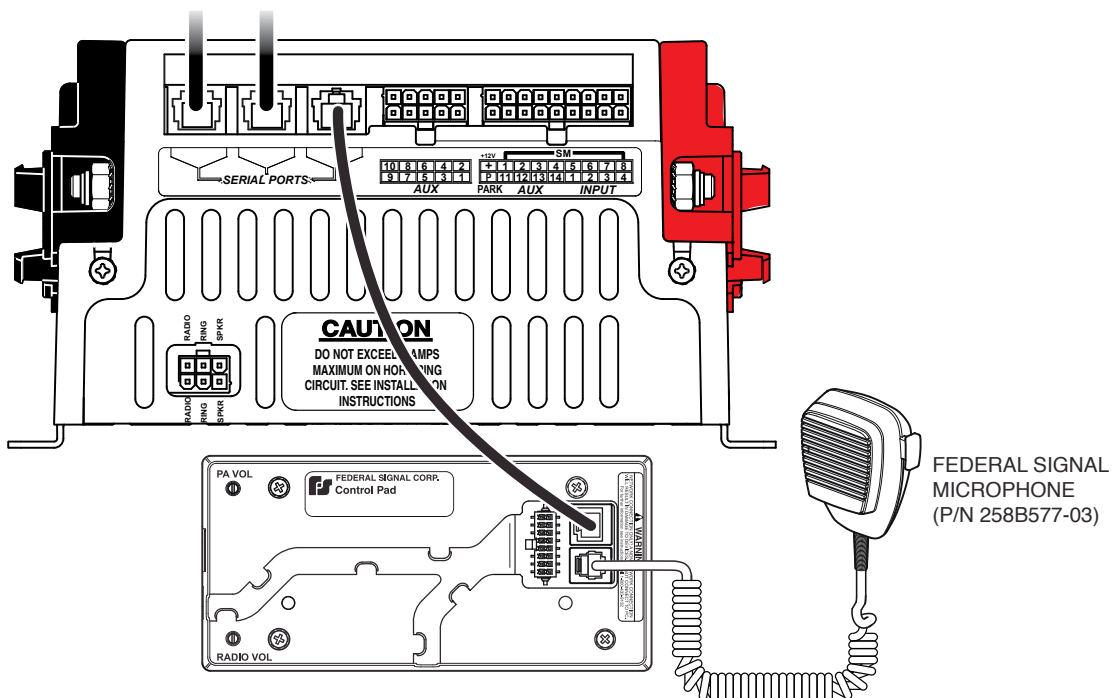

Connecting the Siren to the Battery

This section has instructions for making the power connections from the SmartSiren to the battery. Required are an installer-supplied in-line fuse and wiring of an amperage capacity sufficient to handle the total vehicle electrical loads.

⚠ WARNING

BATTERY EXPLOSION—*To avoid a battery explosion, always disconnect the negative battery cable first and reconnect it last. Avoid causing a spark when connecting near or to the battery. The gases produced by a battery can cause a battery explosion that could result in vehicle damage and serious injury.*

⚠ CAUTION

HIGH CURRENT ARCING—*Do not connect this system to the vehicle battery until ALL other electrical connections are made and you have verified that no shorts exist. High current conductors can cause hazardous sparks or burning wire resulting in electrical fires.*

Preparing to Connect the Power Leads

Before connecting the amplifier/relay module to the battery, ensure that your final installation goes smoothly by taking these preparatory steps:

1. Check all connections and wiring to ensure they are correct and secure.
2. Ensure that there are no loose strands or other bare wires that may cause a short circuit. Protect all wires from any sharp edges that could eventually cut through the insulation.
3. Verify that all other electrical connections are completed and that no shorts exist.
4. Use an ohmmeter to verify that a short circuit does not exist between the positive (+) and negative (–) battery cable leads. Also, there must be no short circuits between the positive wires and the vehicle chassis.

Connecting the Power Leads to the Vehicle Battery

See Figure 3.15 on page 36. The installer-supplied red (positive) and black (negative ground) power leads from the siren amplifier/relay module to the vehicle battery should be as short and direct as possible.

1. Route the red lead and black lead from the siren to the battery.
2. Crimp a ring terminal on the red lead and connect it to the positive (+12V) battery terminal.
3. Crimp a ring terminal on the black lead and connect it through an in-line fuse to the negative (–NEG) battery terminal. The fuse must be of an amperage capacity sufficient to handle the total vehicle electrical loads.
4. Reconnect the positive cable to the vehicle battery and tighten the clamp.
5. Reconnect the negative cable to the vehicle battery and tighten the clamp.

Figure 3.16 Negative ground connection for the control head

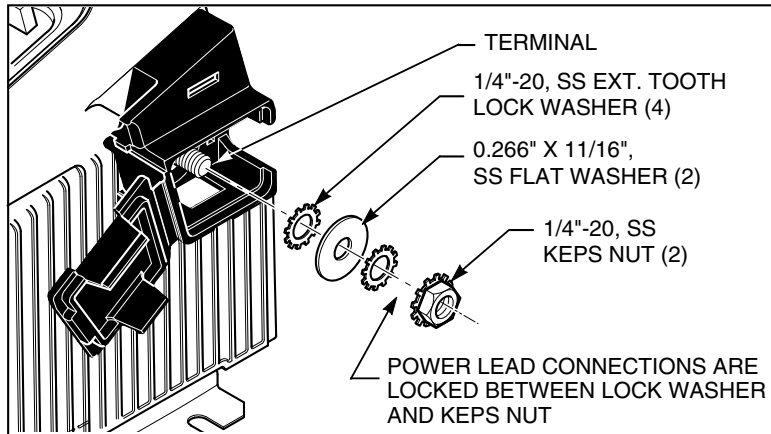

CHAPTER 4

Setting the Gain for Radio Rebroadcast and PA

The radio rebroadcast feature allows incoming two-way radio messages to be amplified by the siren amplifier/relay module and rebroadcast over the siren speakers of the SSP3000B system. The feature overrides all sirens functions. **Button 7** is programmed as the default control for radio rebroadcast.

The gain control for radio rebroadcast is a recessed potentiometer on the front of the siren amplifier/relay module (Figure 4.2 on page 38). Wiring connections are described in “Radio Rebroadcast (Cable Assembly P/N 17500307)” on page 31.

For public address, the Smart Siren Platinum System includes a microphone that connects to a serial port on the back of the control head. When the operator presses the microphone push-to-talk button and speaks into the microphone, the operator’s voice is amplified and broadcast over the siren speakers. The primary control for adjusting the PA gain is a recessed potentiometer on the front of the siren amplifier/relay module (Figure 4.3 on page 38). A secondary control for the PA gain is a recessed potentiometer on the back of the control head (Figure 4.4 on page 39).

Setting the Gain for Radio Rebroadcast

To adjust the gain for radio rebroadcast:

1. Stand outside the vehicle in an inclosed area and turn on the two-way radio.
2. Adjust the volume level of the radio to its normal operating volume.
3. Press **Button 7** on the control head to turn on radio rebroadcast (Figure 4.1).

Figure 4.1 Default control head button for radio rebroadcast

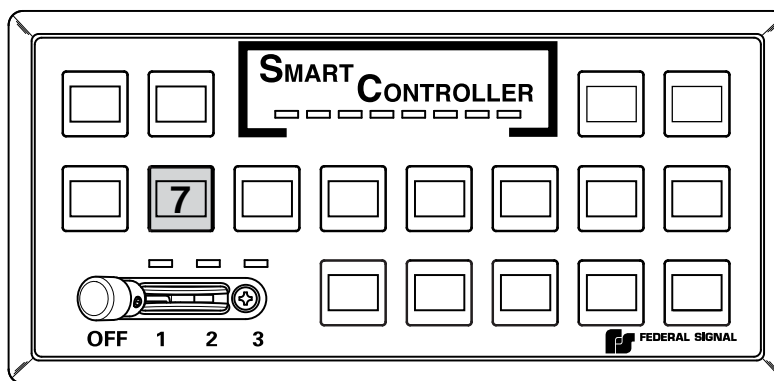

- Stand outside of the vehicle and note the volume level of the radio rebroadcast. If the volume is too loud or too soft, insert a small flat-head screwdriver in the gain control port for radio rebroadcast (**RAD VOL**) on the front of the siren amplifier/relay module (Figure 4.2). Turn it counter-clockwise to increase the volume until audio feedback (squeal) occurs or clockwise to decrease the volume.
- To turn off radio rebroadcast, press **Button 7**.

Figure 4.2 Gain control for radio rebroadcast (siren amplifier/relay module)

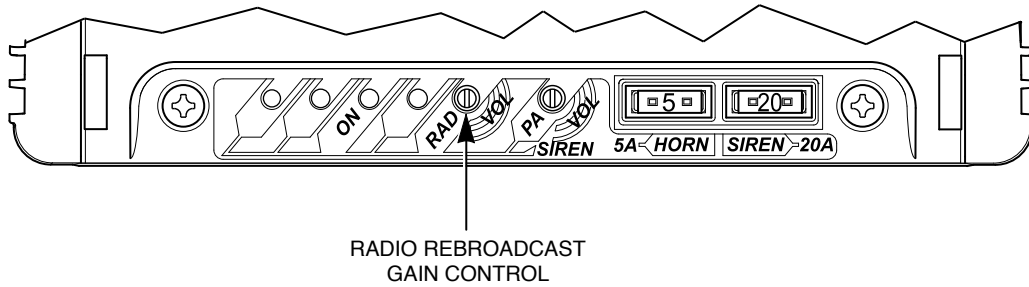

Setting the Gain for Public Address (Microphone Volume)

The PA gain control port on the front of the siren amplifier is for select models that require the microphone to be connected to the siren.

To adjust the PA gain:

- Stand outside the vehicle in an enclosed area and press the push-to-talk button on the control head microphone. Speak into the microphone in a normal tone of voice.
- If the speaker volume is too loud or too soft, insert a small screwdriver in the PA gain control port (**PA VOL**) on back of the control head. (Figure 4.3). Turn it clockwise to increase the volume until audio feedback (squeal) occurs or counter-clockwise to decrease the volume.

NOTE: Audio feedback depends upon the microphone gain, open windows, speaker placement, and the proximity of reflecting surfaces such as walls, buildings, or other vehicles.

Figure 4.3 Gain control for PA (amplifier/relay module)

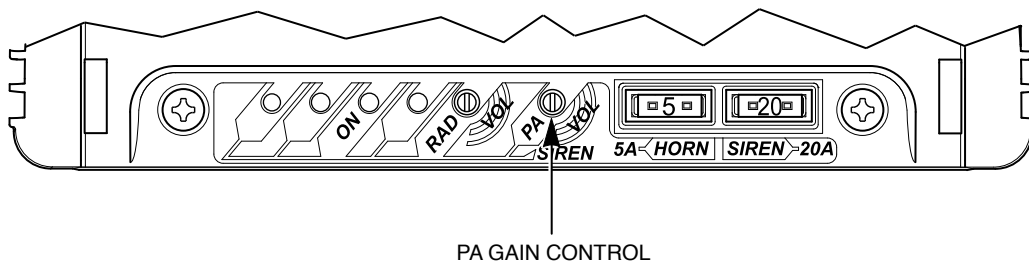

CHAPTER 5

Mounting the Siren and Control Head

The next step in the installation after wiring and connecting the SSP3000B/SSP2000B system is to permanently mount the siren amplifier/relay module and control head in the vehicle. Verify that the mounting locations you selected earlier are safe for installing these components. Before proceeding, review the following precautions before mounting the equipment.

⚠ WARNING

AIRBAG DEPLOYMENT—Do not install equipment or route wiring in the deployment path of an airbag. Failure to observe this warning will reduce the effectiveness of the airbag or potentially dislodge the equipment, causing serious injury or death.

⚠ WARNING

SEAT REMOVAL PRECAUTION—If a vehicle seat is temporarily removed, verify with the vehicle manufacturer if the seat needs to be recalibrated for proper airbag deployment.

NOTICE

UNIT REQUIRES AIR FLOW (SSP3000B ONLY)—The siren amplifier/relay module is cooled by an internal fan. Do not install it in areas where the air flow is restricted. Do not mount the unit near a heater duct or under the hood.

NOTICE

UNIT IS NOT WATERPROOF—The housing of the siren amplifier/relay module is NOT waterproof. The module must be mounted in a location that is sheltered from falling rain, snow, standing water, etc.

NOTICE

DRILLING PRECAUTIONS—When drilling holes, check the area you are drilling into to be sure you do not damage vehicle components while drilling. All drilled holes should be de-burred and all sharp edges should be smoothed. All wire routings going through drilled holes should be protected by a grommet or convolute/split loom tubing.

Mounting the Siren Amplifier/Relay Module

Installer-supplied #10-32 mounting hardware is required to mount the siren amplifier/relay module.

Tools needed:

- #18 tap drill for steel and iron
- Phillips screwdriver
- Pencil or felt-tip pen for marking drill locations

To mount the siren amplifier/relay module in the vehicle:

1. Use the base of the siren amplifier/relay module as a template (Figure 5.1) or the dimensions shown in Figure 5.1 to mark the centers of the four mounting holes.

Figure 5.1 Slots for mounting hardware

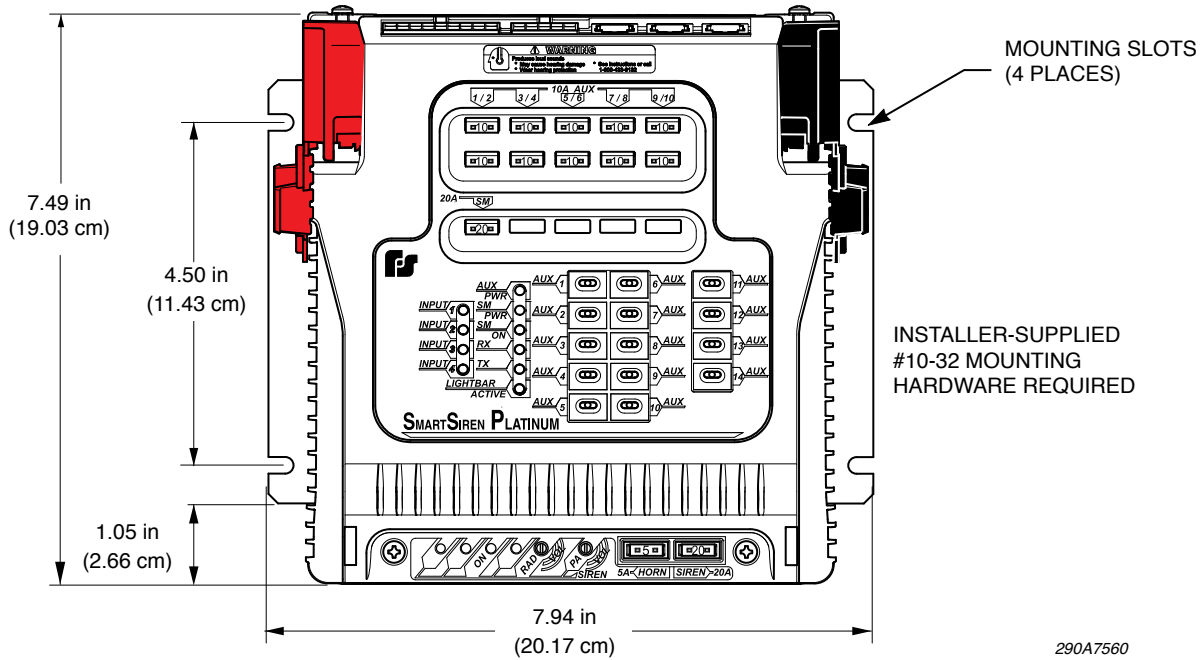

2. Tap and drill the center of the four mounting holes.
3. Center the slots in the base of the siren amplifier/relay module over the drilled holes and secure it with the installer-supplied #10-32 mounting hardware.

Mounting the Control Head

The control head comes with two mounting brackets and mounting hardware.

Tools needed:

- Drill with #9 drill bit
- Phillips screwdriver
- 7/16" nut driver
- Pencil or felt-tip pen for marking drill position locations

To mount the control head:

1. Secure a bracket to the control head with the 6-32 x 1/4 Phillips screws and #6 lock washers (Figure 5.2 on page 42).
2. Using a 7/16" nut driver, secure the other bracket to the control head/bracket assembly with the 1/4-20 x 3/4 hex head screws and 1/4" lock washers (Figure 5.3).

3. Use the mounting bracket as a template and scribe two drill position marks at the selected mounting location.

Figure 5.2 Bracket attached to back of control head

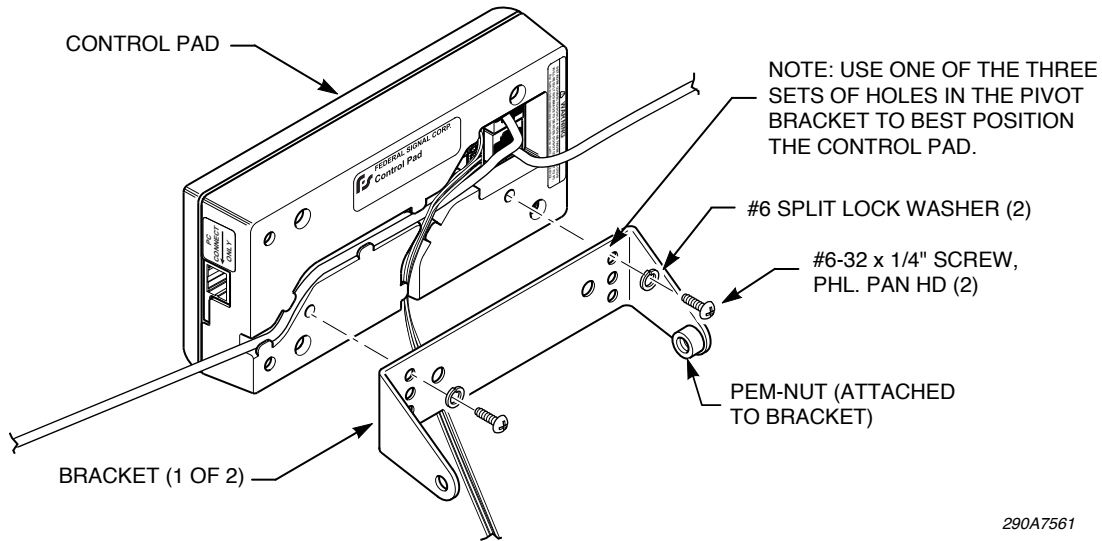

4. Drill two pilot mounting holes at the drill position marks.
5. Secure the mounting bracket to the mounting surface with the #10 thread-forming screws (Figure 5.3).
6. To adjust the angle of the control head, loosen the hinge screws, tilt the control head forward or backward, then securely tighten the screws.

Figure 5.3 Brackets attached to control head and mounting surface

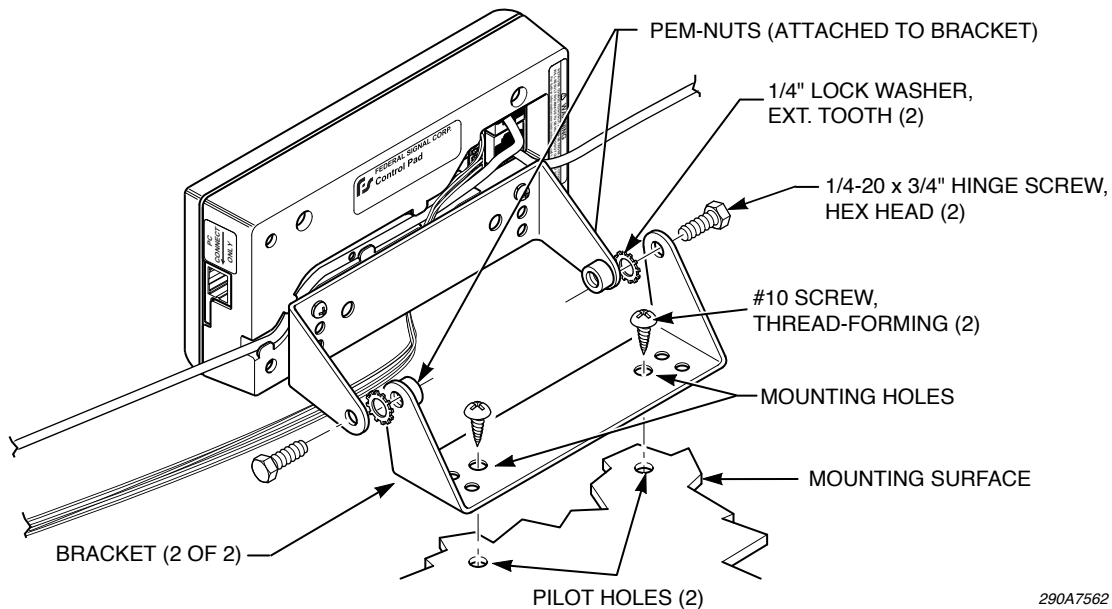

CHAPTER 6

Setting Control Head Options

The SmartSiren Platinum control head has these configurable features:

- ◆ A notification beep that sounds every ten seconds when one or more functions or devices in the system, such as a lightbar, is activated. The default setting is “on.”
- ◆ Step-through selection of one of four levels of LED dimming, including “off.” The default setting is at the brightest level
- ◆ Selection of active-high activation of the Park Input circuit
- ◆ Selection of active-high activation of the horn-ring transfer circuit
- ◆ The operation and control of network devices, which are resettable to the factory-default configuration (see Figure 7.1 on page 44 or Figure 7.2 on page 45 and the Convergence Configuration Software Manual, doc. no. 2562418).
- ◆ Keep alive timeout if using the ignition timer. The default setting is immediately with the ignition timer function.

To help you confirm your selection, the button you press glows while the control head beeps every 10 seconds. Additionally, one or more amber LEDs turn on in the row at the top of the control head (Figure 6.1 on page 44). These LEDs identify the button and its associated setting. These LEDs identify the button and its associated setting.

Entering Program Mode

To set the control head options, first enter Program Mode:

1. Press and hold **Button 6** while powering up the control head (Figure 6.1 on page 44).
2. During the long beep, release Button 6. The control head beeps continuously.
3. Verify that the first amber LED is on.

Turning Off or On the 10-Second Notification Beep

The control head beeps every 10 seconds when you are in Program Mode. To turn the beep off or on:

1. While in Program Mode, press **Button 12** (Figure 6.1 on page 44).
2. To continue, select another setting to change or press **Button 13** to exit Program Mode. Verify that the last amber LED turns on when you exit.

- To continue, select another setting to change or press **Button 13** to exit Program Mode. Verify that the last amber LED turns on when you exit.

Figure 6.1 LEDs and buttons associated with Program Mode settings

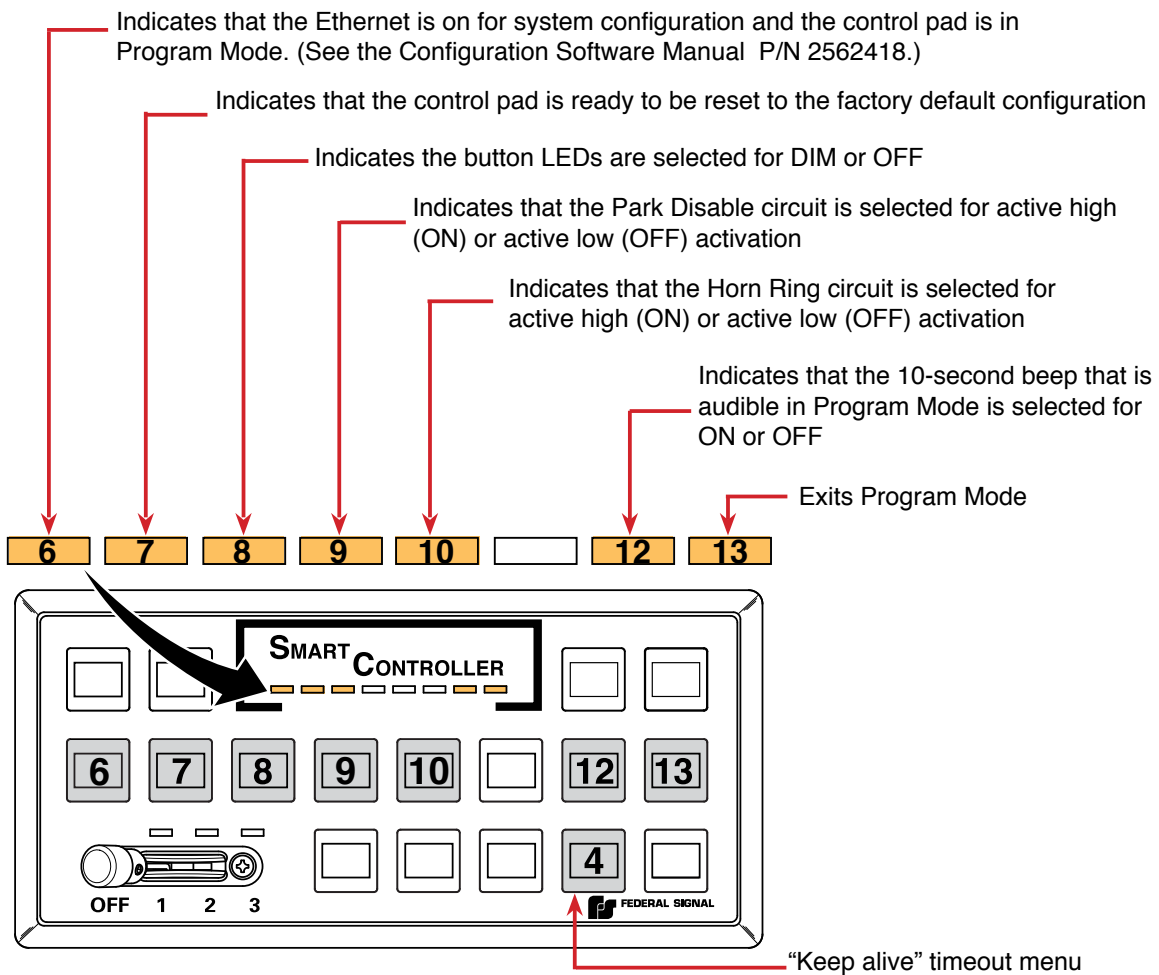

Selecting Active-High Activation of Horn-Ring Transfer

For instructions on connecting the horn-ring circuit for siren-tone control, see “Horn Ring Transfer (Cable Assembly P/N 17500307)” on page 28.

The default setting is active-low.

To select active-high activation of the Park Input feature:

- While in Program Mode, press **Button 10**. LED 10 in Figure 6.1 turns on.
- To continue, select another setting to change or press **Button 13** to exit Program Mode. Verify that the last amber LED turns on when you exit.

Selecting Active-High Activation of the Park Input Circuit

For instructions on connecting the control head to the Park Input circuit, see “Park Input (Cable Assembly P/N 1751542-01 and 1752542-NY)” on page 26.

The default setting is active-low. To select the active-high activation of the Park Input feature:

1. While in Program Mode, press Button 9. LED 9 in Figure 6.1 turns on.
2. To continue, select another setting to change or press Button 13 to exit Program Mode. Verify that the last amber LED turns on when you exit.

Dimming or Turning Off the Button LEDs

To dim or turn off the button LEDs:

1. While in Program Mode, press **Button 8** up to four times to step through decreasing levels of brightness (Figure 6.1 on page 44). To turn off the LEDs, press **Button 8** a fifth time.
2. To continue, select another setting or press **Button 13** to exit Program Mode. Verify that the last amber LED turns on when you exit.

Configuring Keep-Alive Timeout

For instructions on connecting the ignition sense, see “Connecting Power to the Control Head (with Ignition Timer)” on page 33. The default setting is to disable the control head immediately with ignition. To maintain power to the SmartSiren Platinum control head and other Convergence Network devices after ignition is removed:

1. While in Program Mode, press **Button 4**. The first press enters the Keep Alive Timeout menu, and Button 4 starts flashing. Press Button 4 to increase the length of time the control head stays alive. The amber LEDs indicate the timeout level (Figure 6.2).
2. To return to the Program Menu, press any other button or wait five seconds. To continue, select another setting or press **Button 13** to exit Program Mode. Verify that the last amber LED turns on when you exit.

Figure 6.2 Keep-Alive Timeout durations

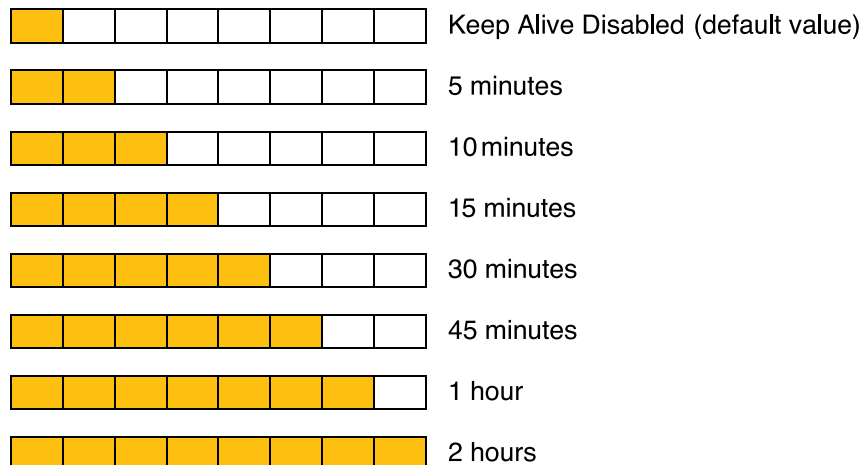

Resetting the Control Head to the Factory Default Configuration

To reset the operation and control of network devices to the factory default:

1. While in Program Mode, press **Button 7** (Figure 6.1 on page 41).
2. To continue, select another setting to change or press **Button 13** to exit Program Mode. Verify that the last amber LED turns on when you exit.

Exiting Program Mode

To exit Program Mode

1. Press **Button 13** (Figure 6.1 on page 41).
2. Verify that the last amber LED turns on when you exit.

CHAPTER 7

Testing the Convergence Network Installation

⚠ WARNING

SOUND HAZARD—All effective sirens and horns produce loud sounds (120 dB) that may cause permanent hearing loss. Always minimize your exposure to siren sound and wear hearing protection. Do not sound the siren indoors or in enclosed areas where you and others will be exposed to the sound.

⚠ WARNING

LIGHT HAZARD—To be an effective warning device, an emergency warning system produces bright light that can be hazardous to your eyesight when viewed at a close range. Do not stare directly into this lighting product at a close range or permanent damage to your eyesight may occur.

The control head is programmed with a default configuration that you can use to quickly check your initial installation of the SSP3000B system before you configure the control head. For illustrations showing the default configurations for the control head and for the steering wheel switches (if connected to the four control head input circuits), see page 48 for the SSP2000B and page 49 for the SSP3000B. For the default configuration for steering wheel switches wired to control head for both the SSP2000B and SSP3000B, see page 50.

When you test the system, be sure to note the status of the LED indicators in the externally mounted fuses of the siren amplifier/relay module. Also note the activity of the LEDs just below the surface of the module. The illustrations on the following pages describe what each LED indicates. Also verify that the 10-second function notification beep and lightning options of the control head work as expected.

In addition, test all vehicle functions, including horn operation, vehicle safety functions, and vehicle lighting systems for proper operation. Ensure that the installation has not affected the vehicle operation or changed any vehicle safety functions or circuits. Do not test the sound and light system of the vehicle while driving. Operating the vehicle warning system may pose a hazard to the operator and other drivers if the system does not function as expected. Test the vehicle only in a controlled environment. After testing is complete, provide a copy of this manual to the instructional staff and all operating personnel.

Figure 7.1 SSP2000B default configuration for control head

Signal Master Rear Lightbar Left, Right, Center Out		Warn SignalMaster Rear Lightbar Step-Through Warning Patterns 1 to 4		<h1>SSP2000B</h1>				Button 14 Button Control: Push On/Off Lightbar: Dimming LB	Button 15 Button Control: Push On/Off Rear Light Cutoff
Button 6 Button Control: Exclusive Siren: Standby	Button 7 Button Control: Exclusive Siren: Radio	Button 8 Button Control: Push On/Off Lightbar: Scene Light Relay: Active Hi/Lo 10 A Steady On Active High Open Off	Button 9 Button Control: Exclusive Siren: On Power Up Wail	Button 10 Button Control: Exclusive Siren: Yelp	Button 11 Button Control: Exclusive Siren: Priority	Button 12 Button Control: Momentary Siren: Manual	Button 13 Button Control: Momentary Siren: Air Horn		
Slide Switch 1 Button Control: Momentary Front Light Cutoff Lightbar: Pattern 10 Active Hi 10 A Relay 1: Active High Steady On Open Off	Slide Switch 2 Button Control: Momentary Lightbar: Pattern 17 Horn Ring Transfer Active Hi 10 A Relays 1-3: Active High Steady On Open Off	Slide Switch 3 Button Control: Momentary Flash Take-down/Alley Lightbar Pattern 26 Siren Dependent Enabled Horn Ring Transfer Active Hi 10 A Relays 1-5: Active High Steady On Open Off	Button 1 Button Control: Push On/Off Lightbar: Left Alley	Button 2 Button Control: Push On/Off Lightbar: Takedowns	Button 3 Button Control: Push On/Off Lightbar: Right Alley	Button 4 Button Control: Timer 8 Seconds Lightbar: Intersection Pattern 22	Button 5 Button Control: Security Timer 8 Seconds Active Hi 10 A Relay 6: Active High Steady On		

Figure 7.2 SSP2000B control head and ignition timer inputs

Control Head Input 1 Button Control: Momentary Active Slide Switch 1	Control Head Input 2 Button Control: Momentary Active Slide Switch 2	Control Head Input 3 Button Control: Momentary Active Slide Switch 3	Control Head Input 4 Button Control: Momentary Active Button 2	Amperage Input 1 Ignition Timer Button Control: Momentary Active Hi 2 A Output Relay 11	Amperage Input 2 Ignition Timer Button Control: Momentary Active Hi 2 A Output Relay 12	Amperage-Input 3 Ignition Timer: Button Control: Momentary Active Hi 2 A Output Relay 13	Amperage Input 4 Ignition Timer Button Control: Momentary Active Hi 2 A Output Relay 14	Horn Ring Button Control: Momentary Siren: HR Manual	Park Detect Button Control: Momentary Input Control: Siren Mute (except Air Horn and Manual) Input Control: Lightbar: White Light Cutoff (in Park)
-----------------------------------------------------------------------------------	-----------------------------------------------------------------------------------	-----------------------------------------------------------------------------------	-----------------------------------------------------------------------------	------------------------------------------------------------------------------------------------------	------------------------------------------------------------------------------------------------------	-------------------------------------------------------------------------------------------------------	------------------------------------------------------------------------------------------------------	-------------------------------------------------------------------	--------------------------------------------------------------------------------------------------------------------------------------------------------------------

Figure 7.3 SSP3000B default configuration for control head

Signal Master Rear Lightbar 8-Head Discrete Left, Right, Center Out		Warn Step-Through Warning Patterns 1 to 4 Rear Lightbar 8-Head Discrete		<h1>SSP3000B</h1>				Button 14 Button Control: Push On/Off Lightbar: Dimming	Button 15 Button Control: Push On/Off Rear Light Cutoff
Button 6 Button Control: Exclusive Siren: Standby	Button 7 Button Control: Exclusive Siren: Radio	Button 8 Button Control: Push On/Off 10 A Relay 9 Active Hi/Lo: Steady On Active Hi Open Off	Button 9 Button Control: Exclusive Siren: On Power Up Wail	Button 10 Button Control: Exclusive Siren: Yelp	Button 11 Button Control: Exclusive Siren: Priority	Button 12 Button Control: Momentary Siren: Manual	Button 13 Button Control: Momentary Siren: Air Horn		
Slide Switch 1 Button Control: Momentary Lightbar: Front Light Cutoff Pattern 10 Active Hi/Lo 10 A Relay: Steady On Active Hi Open Off	Slide Switch 2 Button Control: Momentary Lightbar: Pattern 17 Horn Ring Transfer Active Hi/Low 10 A Relays 1-3: Steady On Active Hi Open Off	Slide Switch 3 Button Control: Momentary Flash Take-down/Alley Lightbar: Pattern 26 Siren: Dependent Enabled Horn Ring Transfer Active Hi/Low 10 A Relays 1-5: Steady On Active Hi Open Off	Button 1 Button Control: Push On/Off Lightbar: Left Alley Active Hi/Low 10 A Relay 6: Steady On Active H/L, Open Off	Button 2 Button Control: Push On/Off Lightbar: Takedowns Active Hi/Low 10 A Relay 7: Steady On Active High Open Off	Button 3 Button Control: Push On/Off Lightbar: Right Alley Active Hi/Low 10 A Relay 8: Steady On Active High Open Off	Button 4 Button Control: Timer: 8 Second Lightbar: Intersection Pattern 22	Button 5 Button Control: Security Timer: 8 Seconds Active High/Low 10 A Relay 10: Steady On Active High Open Off		

Figure 7.4 SSP3000B control head and ignition timer inputs

Control Head Input 1 Button Control: Momentary	Control Head Input 2 Button Control: Momentary	Control Head Input 3 Button Control: Momentary	Control Head Input 4 Button Control: Momentary	Amperage Input Ignition Timer Button Control: Momentary	Amperage Input Ignition Timer Button Control: Momentary	Amperage Input Ignition Timer Button Control: Momentary	Amperage Input Ignition Timer Button Control: Momentary	Horn Ring Button Control: Momentary Siren: Manual	Park Detect Button Control: Momentary
----------------------------------------------------------	----------------------------------------------------------	----------------------------------------------------------	----------------------------------------------------------	-------------------------------------------------------------------	-------------------------------------------------------------------	-------------------------------------------------------------------	-------------------------------------------------------------------	----------------------------------------------------------------	-------------------------------------------------

Figure 7.5 Default configuration for steering wheel switches wired to control head

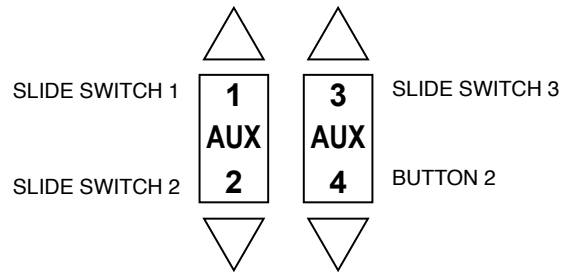

Figure 7.6 LED indicators and fuses on upper part of siren amplifier/relay module

AUX 11–14: LED flashes when the output is on for a 2A auxiliary solid-state relay. These relays are active-high only and are internally protected by electronic short-circuit detection circuits.

SM 20A: 20A fuse for the SignalMaster. (SSP3000B only)

10A AUX 1–10: 10A fuses for 10A auxiliary solid-state relays. Relays 9/10 can be configured as 12 Vdc out or ground out. (Relays 7, 8, 9 are not available on the SSP2000B)

AUX PWR: LED glows in the SSP3000B when battery power and serial cable power are present.

SM PWR: LED glows in the SSP3000B when the SignalMaster has power.

SM ON: LED glows in the SSP3000B when the SignalMaster flashes a pattern.

INPUT 1–4: LEDs glow in the SSP3000B when an input is receiving a signal. Voltage and amperage are required for the signal.

In the SSP3000B each external mini ATM fuse has an integrated LED that glows when the fuse is blown.

The table identifies the color code and amperage.

Color	Amperage
Tan	5
Red	10
Yellow	20

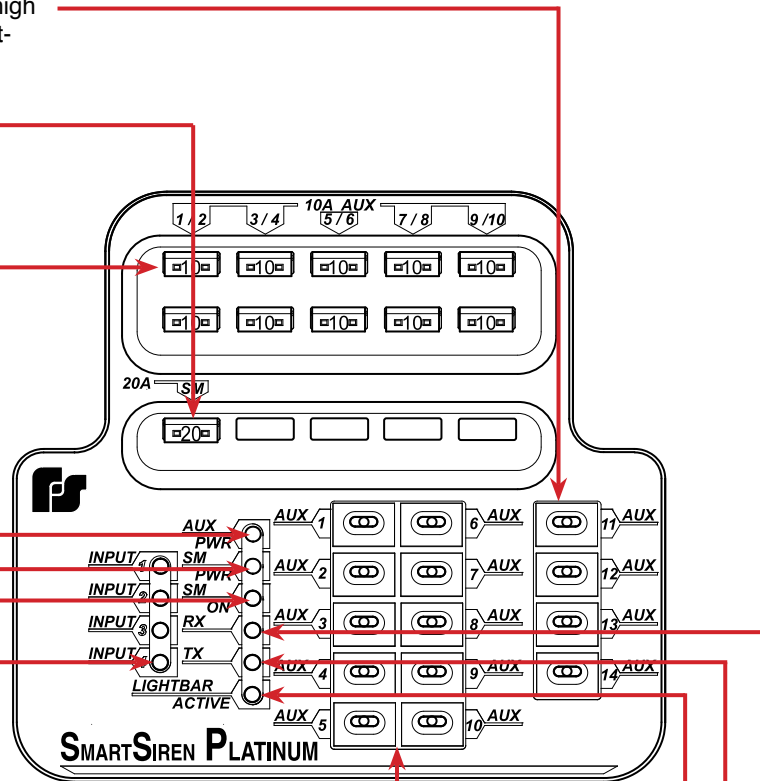

AUX 1–10: LED flashes in the SSP3000B when the output is on for an 10 A auxiliary solid-state relay. Relays can be configured as 12 Vdc out or ground out.

LIGHTBAR ACTIVE: LED glows in the SSP3000B when the lightbar is flashing.

TX (Transmit): LED flashes in the SSP3000B when the relay module transmits a message on the FS Convergence network.

RX (Receive): LED flashes in the SSP3000B when the relay module receives a message on the FS Convergence network.

Figure 7.7 LED indicators on lower label of siren amplifier/relay module

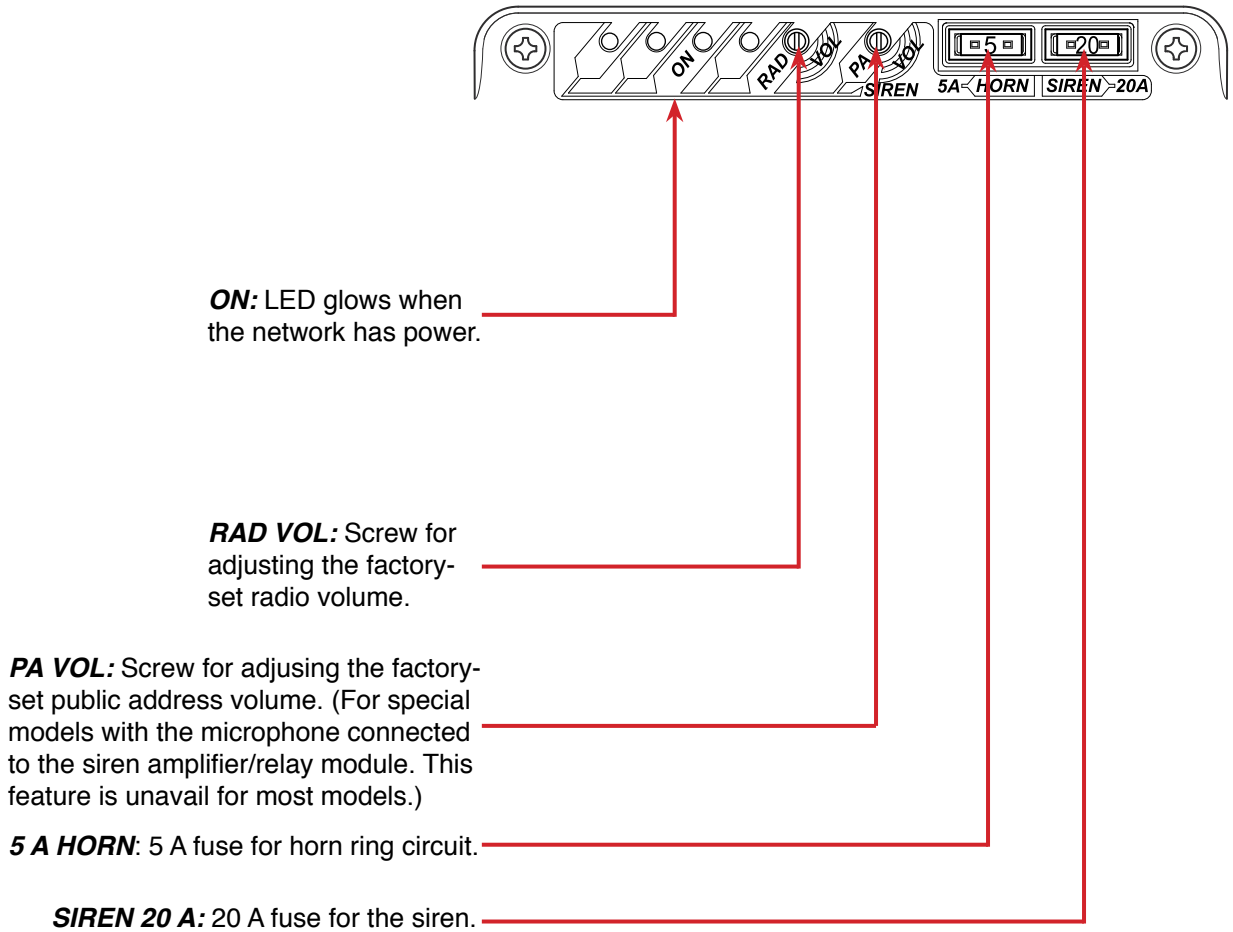
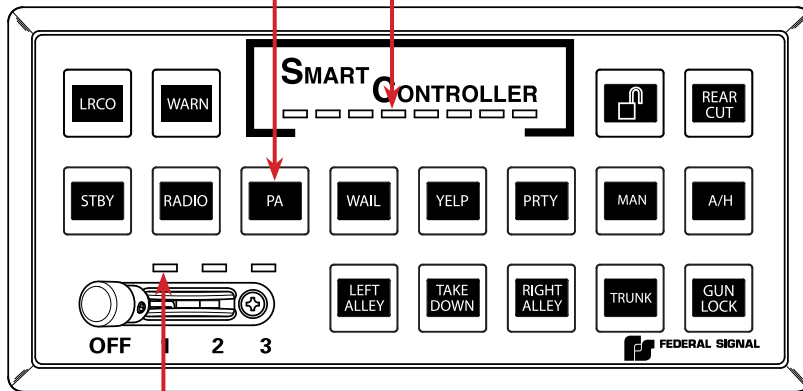

Figure 7.8 LED programming indicators on the control head

The control head legends in the illustration are for a typical configuration. The SSP3000B/SSP2000B kit includes additional legends. All buttons are programmable. For instructions for programming the control head, see the “SSP3000B Control Head Configuration Software Manual” (doc. no. 2562418).

Button LEDs: All buttons on the control head glow when the system is on. Pressed buttons blink to indicate that the function they control is active.

SmartSiren® LEDs: LEDs mimic these active SignalMaster patterns: Left, Right, Center-Out, or Warn patterns 1 to 4. They also indicate when a programmed feature of the key head is active (see “Setting Control Head Options” on page 43.)



SLIDE SWITCH LEDs: LEDs above the slide switch glow when the system is on (1=green, 2=amber, 3=red). The LED brightens above the position in which the slide switch is placed.

CHAPTER 8

Control Head Legends and Safety Messages

To complete the installation, the SmartSiren kit includes:

- ◆ A scored sheet of replaceable keyhead legends that identify the functions of the control head buttons (part no. 181460). Before installing the legends, configure the operation of the control head with the Convergence Configuration Software (see the Convergence Network Software Configuration Manual, part no. 2562418).
- ◆ A scored sheet of two labels with precautions to guard against hearing loss when operating the siren amplifier/relay module (part no. 1612339).
- ◆ A safety message card for operators of Federal Signal Sound and Light System (part no. 256B691).

Applying the Replaceable Control Head Legends

To apply the legends:

1. Peel the appropriate legends from the sheet and apply them to the control head in the areas shown in Figure 8.1.
2. Verify that the label is properly tucked under the retaining ridge on the button.

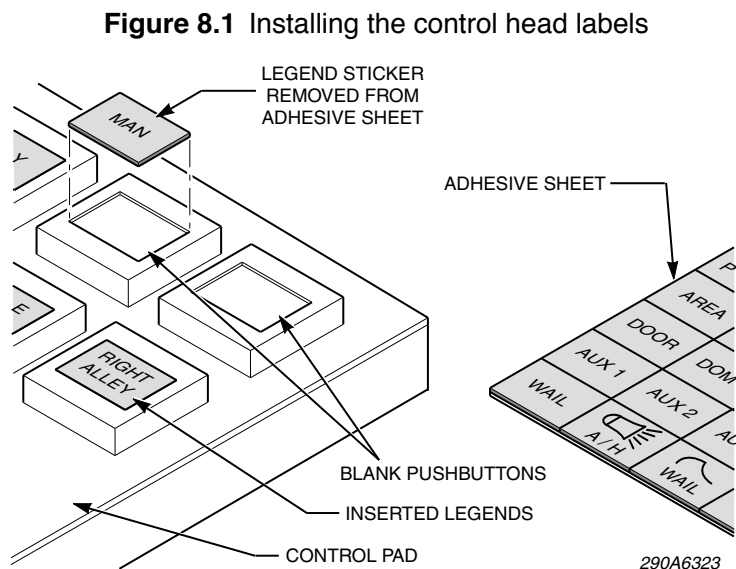

Distributing the Safety Message Card

Give the operator of the system the card entitled “Safety Message to Operators of Federal Signal Light/Sound Systems” (part no. 256B691) (Figure 8.2). The operator must read and understand the safety instructions and keep the card in the vehicle for reference.

Applying the Siren Safety Labels in the Vehicle

The kit includes a sheet of two labels with siren safety messages (part no. 1612339) (Figure 8.2). These labels must be installed in the vehicle in which the system is installed. Install these labels in areas that are clearly visible to operators and passengers. Do not install the labels in locations that would impair the operators’ abilities to operate the vehicle. Never install the labels in areas where airbags may deploy.

Figure 8.2 Safety message card (left) and siren safety labels (right)

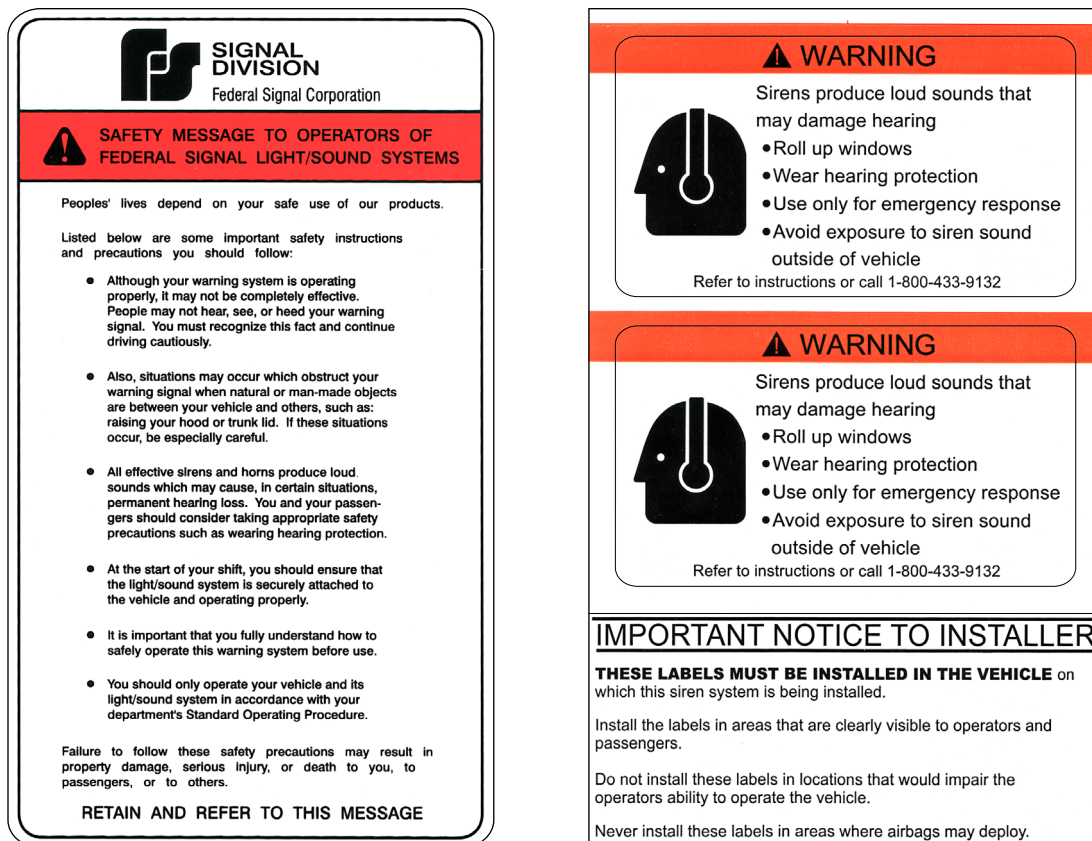

CHAPTER 9

Safety Messages to Personnel Servicing Federal Signal Electronic Sirens

NOTICE

The people's lives depend on your proper servicing of Federal Signal products. It is important to read and follow all instructions shipped with the products. In addition, listed below are some other safety instructions and precautions you should follow:

- Read and understand all instructions in this manual before servicing the electronic siren or control head.
- To properly service an electronic siren or control head, you must have a good understanding of automotive electrical procedures and systems, along with proficiency in the installation and service of safety warning equipment. Always refer to the vehicle service manuals when performing service on a vehicle.
- Electronic repairs must be performed by a qualified and competent electronics technician.
- Your hearing and the hearing of others, in or close to your emergency vehicle, could be damaged by loud sounds. This can occur from short exposures to very loud sounds or from longer exposures to moderately loud sounds. For hearing conservation guidance, refer to federal, state, or local recommendations. OSHA Standard 1910.95 offers guidance on "Permissible Noise Exposure."
- All effective sirens and horns produce loud sounds (120 dB) that may cause permanent hearing loss. Always minimize your exposure to siren sound and wear hearing protection. Do not sound the siren indoors or in enclosed areas where you and others will be exposed to the sound.
- Do NOT connect this system to the positive terminal of the battery until servicing is complete and you have verified that there are no short circuits to ground.
- For the electronic siren to function properly, the ground connection must be made to the NEGATIVE battery terminal.
- After repair, test the electronic siren and speaker system to ensure that it is operating properly.
- Federal Signal siren amplifiers and speakers are designed to work together as a system. Combining a siren and speaker from different manufacturers may reduce the warning effectiveness of the siren system and may damage the components. You should verify or test your combination to make sure the system works together properly and meets both federal, state and local standards or guidelines.

Failure to follow all safety precautions and instructions may result in property damage, serious injury,

or death.

CHAPTER 10

Servicing the Convergence Network System

Federal Signal recommends that the siren amplifier/relay module and control head be returned to your local distributor or Federal Signal for service. External components such as cabling, fuses, and the red and black insulators are available as replacement parts (see Table 10.1 on page 63). With the exception of the slide switch in the control head, there are no other user-serviceable parts within the control head or the siren amplifier/relay module. After servicing the system, test it to ensure that it is operating properly. For more information, see “Testing the Convergence Network Installation” on page 47.

Replacing the Slide Switch

The slide switch can be removed from the control head for replacement or service without disassembling the entire control head. The slide switch is secured to the front of the control head by a bezel and two 1/4"-20 x 3/4" screws. The switch is connected to the four-pin J3 connector on the back of control head assembly, which lies below the logic control and power control PCBs and is easily accessible.

NOTICE

STATIC SENSITIVE DEVICE—*The circuitry of the control head can be damaged by electrostatic discharge. Follow anti-static procedures removing the slide switch.*

Tools needed:

- 7/16" nut driver
- Small Phillips screwdriver
- Small needle-nose pliers
- 1/64" hex key wrench

Dismounting and Disconnecting the Control Head

To remove the control head:

1. Use a 7/16" nut driver to remove the two 1/4"-20 x 3/4" hinge screws securing the two mounting brackets together. Retain the screws and the two 1/4" external-tooth lock washers (Figure 10.1 on page 58).
2. Remove the two #6-32 x 1/4" Phillips screws securing the bracket to the rear of the control head (Figure 10.2 on page 58). Retain the screws and the two #6 lock washers.

3. Disconnect the cables and leads from the back of the control head.

Figure 10.1 Control head removed from mounting surface

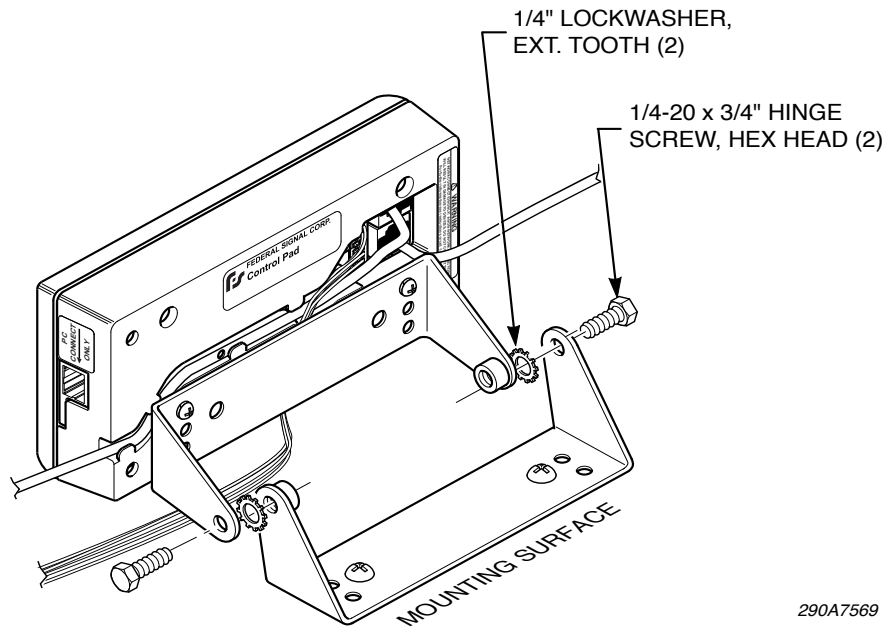

290A7569

Figure 10.2 Control head removed from mounting brackets

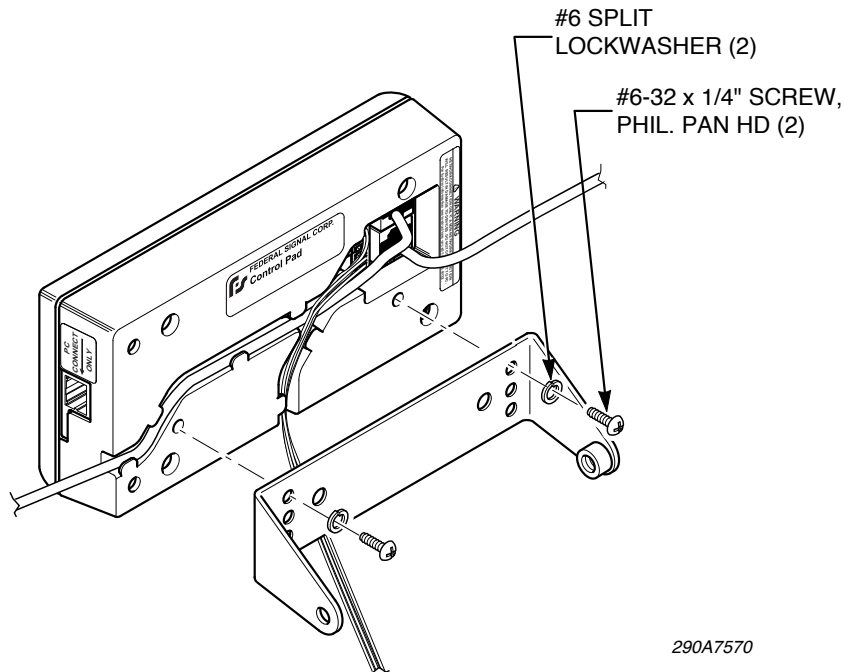

290A7570

Replacing the Slide Switch in the Control Head

To replace the slide switch:

1. Remove and retain the four Phillips #6-32 x 5/16" screws securing the control head base to the control head assembly (Figure 10.3).
2. Remove and retain base of the control head.
3. Note the orientation of the wires of the slide switch connector. Unplug it from the four-pin J3 connector on the control head assembly.
4. Note the orientation of the slide switch knob. Use a 1/64" hex key wrench to loosen and remove the set screw securing the knob to the shaft. Retain the set screw and knob.
5. Loosen and remove the two #4-40 x 5/16" Phillips head screws securing the slide switch bezel to the control head assembly. Retain the screws.
6. Place the new switch assembly in position with the knob in the same orientation as the old switch.
7. Secure the bezel to the control head assembly with the two #4-40 x 5/16" Phillips head screws.
8. Plug the slide switch connector into the four-pin J3 connector on the control head assembly. Ensure that the wires on the connector face the edge of the board.
9. Secure the control head base to the control head assembly with the four #6-32 x 5/16" Phillips screws.

Figure 10.3 Slide switch removed from control head

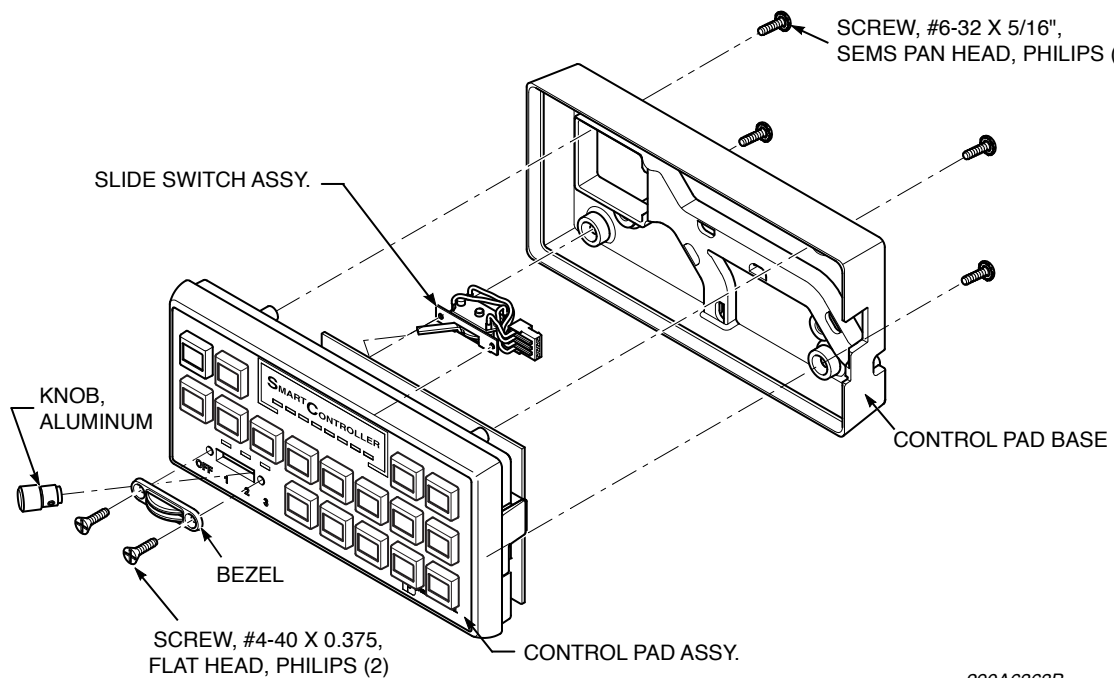

290A6363B

Reinstalling the Control Head

To reinstall the control head in the vehicle:

1. Reconnect the cables and wiring to the control head.
2. Secure the rear mounting bracket to the control head base with the two Phillips #6-32 x 1/4 screws (Figure 10.2 on page 58).
3. Secure the rear mounting bracket to the mounting surface bracket with the two 1/4" external-tooth lock washers and 1/4"-20 x 3/4" hinge screws (Figure 10.1 on page 58.)

Servicing the Siren Amplifier/Relay Module

Servicing the siren amplifier includes replacing damaged cables or external wiring, external fuses and the red and the plastic terminal insulators. The siren amplifier/relay module has 13 externally mounted mini-blade fuses for the siren, horn-ring circuit, SignalMaster, and auxiliary relays have LEDs that glow when the fuse fails. For detail on the components the fuses protect, see Figures 7.1 and 7.2 on page 48. Replacements fuses are obtainable at auto parts stores, from your local distributor. For information on ordering replacement parts from Federal Signal, see page 63.

Tools needed:

- 7/16" nut driver
- Small needle-nose pliers
- Flat-head screwdriver

Uninstalling the Siren Amplifier/Relay Module

To uninstall the siren amplifier/relay module from the vehicle:

1. Remove and retain the installer-supplied #10 hardware.
2. To access the power connections, use a large screwdriver to pry open the covers on the red and black insulators.
3. Use a 7/16" nut driver to remove the 1/4"-20 Keps nuts securing the power cables to the terminals. Retain the two Keps nuts, the four external-tooth lock washers, and two flat washers.
4. Disconnect the Convergence network cable, serial cables and wiring from the rear of the siren amplifier/relay module.

Replacing an External Fuse

To replace a fuse:

1. Investigate and correct the cause of the fuse failure.
2. Remove a fuse by pulling it out with a pair of needle-nose pliers. Be careful not to bend the blades.
3. Insert the blades of the new fuse of the same type and amperage into the appropriate fuse holder beneath the surface of the housing. Make sure that it is properly seated.

Figure 10.4 External parts assembly (SSP3000B shown)

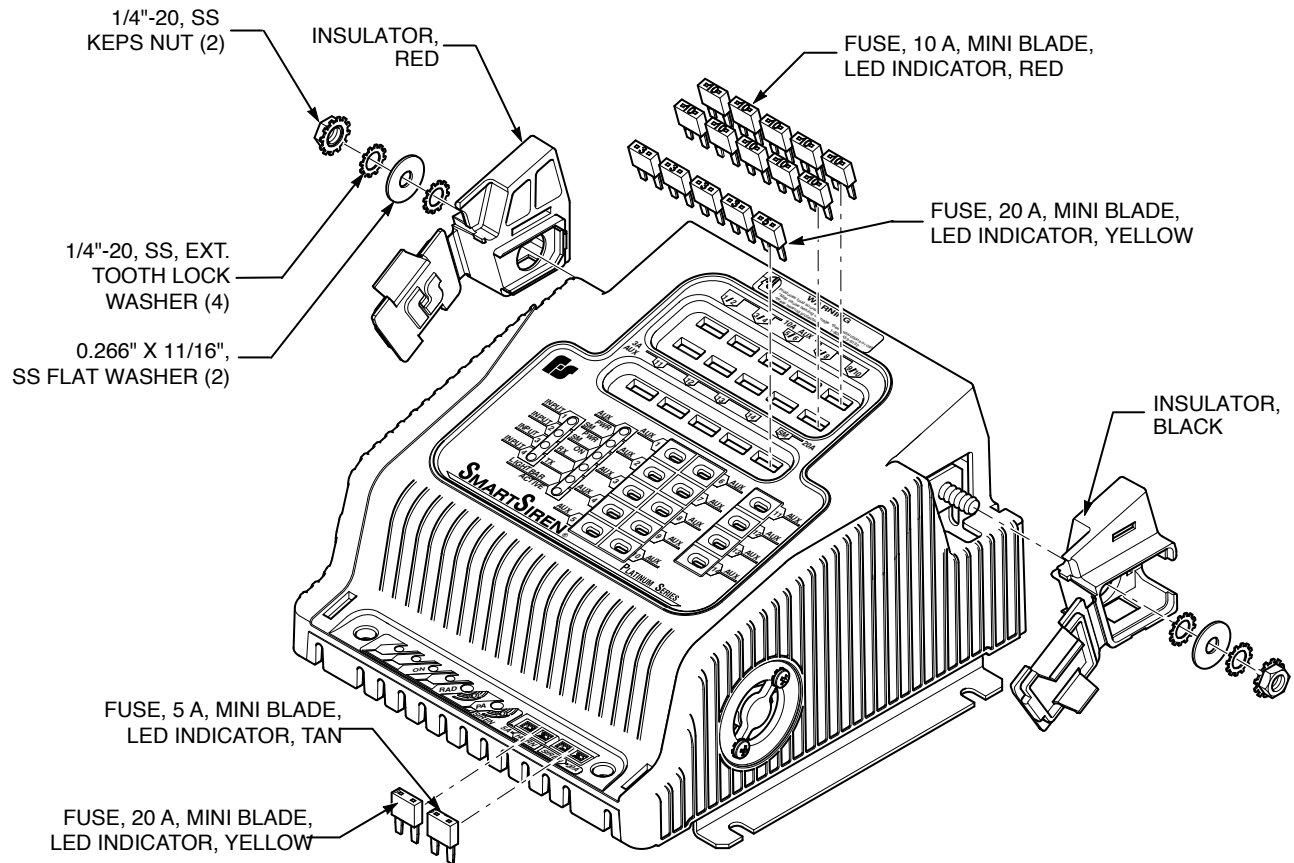

Replacing a Terminal Insulator

To replace an insulator:

1. Ensure that Keps nuts, the two lock washers, and the two flat washers are removed from the terminal (Figure 10.4 on page 61).
2. Note the locations of the locking tabs in Figure 10.5. Insert a flat-head screwdriver between the housing and the insulator near the front locking tab and pry off the insulator.

Figure 10.5 Locking tabs on red insulator

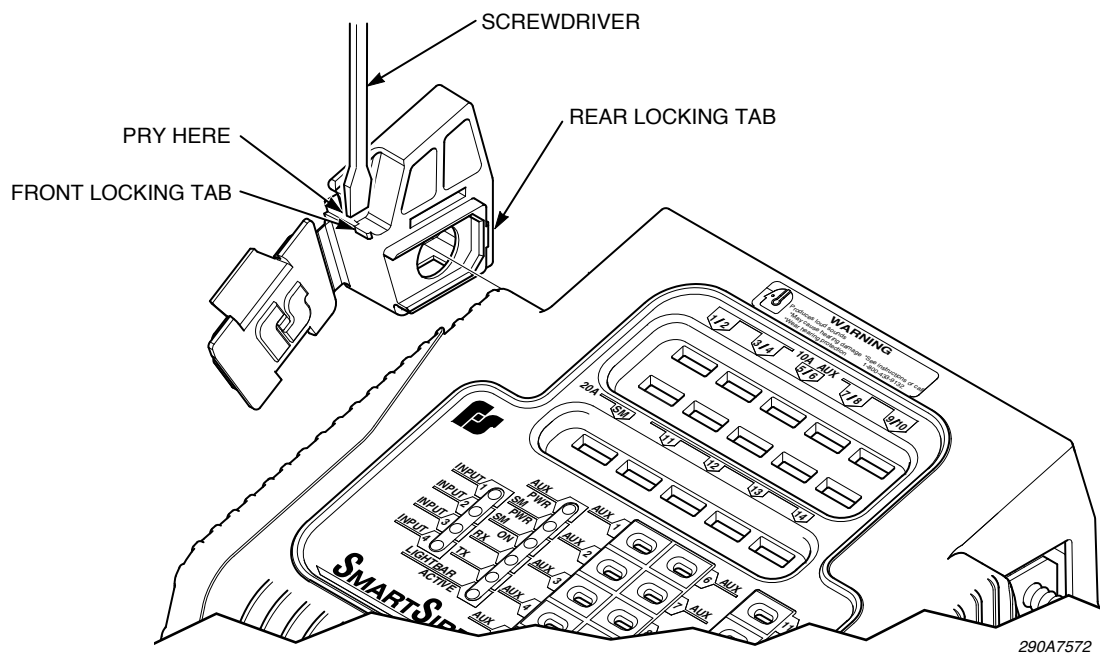

3. Place the new insulator on the terminal and insert the rear locking tab into the housing.
4. Push the front of the insulator against the housing to lock the front tab.

Reinstalling the Siren Amplifier/Relay Module

To reinstall the siren amplifier/relay module in the vehicle (Figure 10.4 on page 61):

1. On the power terminals reinstall a flat washer followed by an external-tooth lock washer.
2. Reconnect the power leads to the terminals and secure them with an external-tooth lock washer and a Keps nut.
3. Reconnect the Convergence Network cable, serial cables, and wiring.
4. Reinstall the siren amplifier/relay module in the vehicle with the installer-supplied #10-32 mounting hardware.

Getting Technical Support and Service

Federal Signal Corporation will service your equipment or provide technical assistance with any problems that cannot be handled locally. Any product returned to Federal Signal for service, inspection, or repair must be accompanied by a Return Material Authorization number. The RMA number can be obtained from your local distributor or Federal Signal. Please provide a brief explanation of the service requested or the nature of the malfunction. Contact your local dealer/distributor for replacement parts availability or contact the Federal Signal Service Department (7 a.m. to 5 p.m., Monday through Friday, Central Time) at:

Service Department
 Federal Signal Corporation
 2645 Federal Signal Drive
 University Park, IL 60484-3167
 800-433-9132
 www.fedsig.com

Ordering Replacement Parts

The cover is available as a service part only. To order replacement parts, please contact:

Customer Support
 Federal Signal Corporation
 Phone: 1-800-264-3578

Table 10.1 Replacement parts

Description	Part Number
Cable Assy., RS485, 25 ft	1751357-02
Cable Assy., Control	17500307
Cable Assy., RJ45, Ethernet Crossover	1751532
Cable Assy., Auxiliary Relay	1751541
SSP3000B Cable Assy., SignalMaster and Inputs	1751542-01
SSP2000B Cable Assy.	1751542-NY
Cable Assy., Control Head	17500308
Cover, SSP3000B	85361196
Keyhead Legends, Scored Sheet	8572294
Fuse, 10 A, Mini Blade	14181-05
Fuse, 20 A, Mini Blade	14181-08
Fuse, 5 A, Mini Blade, LED Indicator	148210-04
Fuse, 10 A, Mini Blade, LED Indicator	148210-06
Fuse, 20 A, Mini Blade, LED Indicator	148210-08
Slide Switch Assy., Control Head	122290-01
Bezel, Slide Switch	8573060
Knob, Aluminum, Slide Switch	85361185
Screw, #4-40 x 0.375, Flat Hd., Phil., Slide Switch Bezel	7000259-06

Returning a Product to Federal Signal

Before returning a product to Federal Signal, call 800-264-3578, 800-433-9132, or 800-824-0254 to obtain a Returned Merchandise Authorization number (RMA number). To expedite the process, please be prepared with the following information:

- Your Federal Signal customer or account number.
- The purchase order number under which the items were purchased.
- The shipping method.
- The model or part number of the product being returned.
- The quantity of products being returned.
- Drop ship information as needed.
- Any estimate required.

When you receive your RMA Number:

- Write the RMA number on the outside of the box of returned items.
- Reference the RMA number on your paperwork inside of the box.
- Write the RMA number down, so that you can easily check on status of the returned equipment.

Send all material with the issued RMA Number to:

Federal Signal Corporation
2645 Federal Signal Drive
University Park, IL 60484-3167
Attn: Service Department
RMA: # _____



2645 Federal Signal Drive, University Park, IL 60484-3167
Tel.: (800) 264-3578 • 708-534-3400 • Fax: (800) 682-8022
www.fedsig.com

© 2015 Federal Signal Corporation