

1. Description

The IntelliSense® IS-320 is a Request-to-Exit Passive Infrared (PIR) sensor. Mounted near an exterior door inside a building with an access control system, the sensor provides free exit to individuals within the building without causing an alarm. The parts of the IS-320 are shown below.

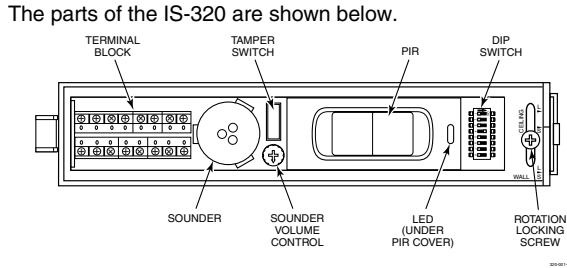

2. Mounting Location

The IS-320 can be mounted on the wall or ceiling.

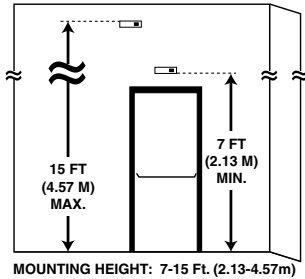

NOTE: If the maximum range of 8.4' (2.6m) is desired, the mounting height must be at the maximum (15' or 4.57m).

Choose a mounting location that:

- Gives the sensor a clear line-of-sight to every part of the detection area. Infrared energy cannot penetrate solid objects; if the PIR cannot detect movement, the sensor will not activate.
- Does not place the sensor directly across from one or more windows.
- Is away from moving machinery, fluorescent lights and heating and cooling sources.

The mounting locations available for a request-to-exit sensor can be fairly limited. You may find that it is impossible to avoid a source of false detection within the IS-320's detection pattern. In that case block the sensor's view of that portion of the pattern by adjusting the shutters as described in section 7.

3. Mounting Procedure

To mount the sensor, do the following:

1. Open the sensor housing by pressing on the latch with a screwdriver. This latch is located on the end of the sensor nearest the lens. Pull the cover up and away from the sensor's base.
2. Loosen rotation locking screw two (2) turns (don't remove). Then, remove PCB assembly from the backplate of the sensor.
3. Insert the wiring into one of the wire channels on the sensor's backplate.

4. Securely affix the sensor's backplate to the wall or ceiling using 2 #6 X 3/4 inch (3.5 X 19 mm) screws provided.
5. Reinstall the PCB assembly and adjust for short or long range as described in section 6. Then, tighten rotation locking screw.

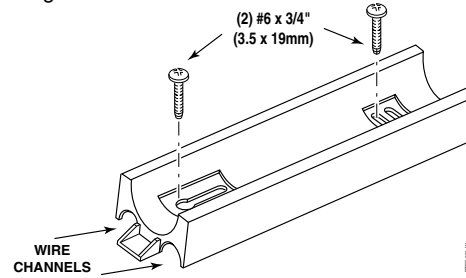

4. Input/Output Description

The IS-320 inputs and outputs are as follows:

V+/V-: Connects to AC or DC power (12 to 28 volts).

Relays: Input/Outputs for the unit's dual double pole/double throw relay. The relay may be used to control a magnetic lock or signal an access control system. All relay connections (common, normally closed, and normally open) for both sets of contacts are available on the terminal block.

- Relay timer settings and the reset mode setting affect operation of this relay (see switches 3, 4, 5, and 6 in DIP Switch Settings).
- Fail Safe/Fail Secure modes are supported (see switch 8 in DIP Switch Settings).

CAUTION: When using the IS-320 to control a magnetic lock, we recommend that an electric suppressor such as S-4 (supplied by Northern Computers) or EL-EDS (manufactured by EDCO) be used to provide transient protection for the magnetic lock and relay contacts. Install the suppressor across the leads connected to the lock as close as possible to the lock.

Tamper: A normally closed switch that opens when the cover is loose or removed from the unit. Both switch contacts are available on the terminal block.

Reader (R)*: An optional input that can be used to activate the unit from an isolated dry contact device. When the input is opened, the unit reacts as if motion was detected. Timer programming and reset modes react normally.

Door (D)*: An optional input to monitor an isolated, normally closed, door contact (door status monitor). The door contact must not be connected to any other system. A DIP switch (see switch 7 in DIP Switch Settings) determines how this input affects unit operation.

Arm (A)*: This optional input may be used to arm and disarm the unit with an isolated dry contact device. These devices might be a second detector, a card reader or keypad, or an access control system. Opening this input allows activation by motion while the input is open, and up to 10 seconds after closure. Once the 10 second timer has expired, the detector is disarmed.

Sounder (S)*: An optional input that can be used to activate the unit's sounder. The sounder will be activated for as long as the terminal is open and takes precedence over all other sounder operation.

Ground (G)*: The G terminals are the returns for inputs. Devices connected to R, D, A, or S should be referenced to the G terminals.

* The unit automatically detects connection to these terminals. If any wiring changes are made, power must be cycled OFF and ON for the IS-320 to detect the change.

5. IS-320 Wiring

Wire the sensor as shown in the illustration.

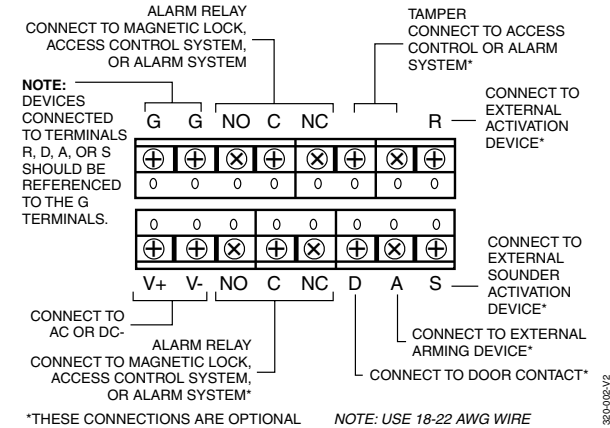

6. Long Range/Short Range Adjustments

The IS-320 can be set to detect individuals at either a long range (several steps from the door) or at short range (immediately in front of the door). If the building includes a lengthy approach to the exit doorway and no other foot traffic in the area, choose the long-range setting.

NOTE: If the maximum range of 8.4' (2.6m) is desired, the mounting height must be at the maximum (15' or 4.57m).

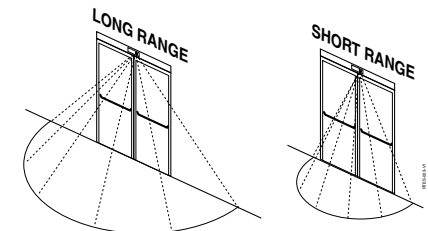

Choose between long- and short-range detection patterns

To set the range length:

1. Loosen the rotation locking screw.
2. Turn the PCB in its rotating base until the arrow on the base is aligned with the appropriate notch on the baseplate. If the sensor is ceiling mounted, choose between the notches with the "Ceiling" label. If the sensor is wall

mounted, choose between the notches with the "Wall" label. The arrow on the mounting base (or back plate) needs to be aligned with the ceiling or wall arrows. ("L" designates long range and "S" designates short range.)
 NOTE: Either long or short range must be selected. Attempting to select a "mid" range will result in undesirable operation. A mid range setting will not result in a mid range operation. It will only provide a long range with attenuated short range detection.

3. Tighten the rotation locking screw.

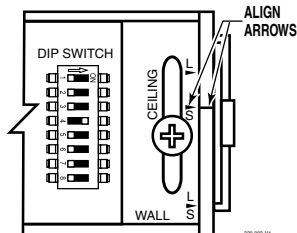

7. Shutter Adjustment

The IS-320 contains shutters behind the PIR cover. These shutters are used to adjust the field width. This may be necessary when the unit is installed where it may be tripped by non-exiting foot traffic or other erroneous sources at either or both edges of the detection area.

1. To adjust shutters, remove the lens cover from the PIR.
2. Push the forward edge of the shutter(s) toward the middle of the opening until the area(s) to be blocked are outside the line-of-sight of the PIR. When making the shutter adjustment, each shutter position has a detent and each detent masks off an entire detection zone. There are eight zones total and each shutter has the ability to mask off 7 of the 8 zones. If the shutter is located between detents, the result will be an attenuation of a zone that is intended to be masked or attenuation of a detection zone resulting in improper operation.
3. Replace the lens cover.

8. DIP Switch Settings

The IS-320 DIP switch contains 8 switches for selecting operating options. The functions of these switches are as follows:

Switch 1 – Sensor Mode (Sensitivity) Selector: OFF is the Request-to-Exit mode. ON is the Security Sensor mode. In the security sensor mode, the sensor is more immune to false alarms, but the extra time required to perform signal qualifications may make the unit unsuitable for most RTE applications. The unit is shipped in Request-to-Exit mode.

Switch 2 – LED Disable: This switch must be off to allow the LED to function. The unit is shipped with the LED enabled (switch OFF).

Switch 3 – Relay Timer Mode: This switch selects the relay timer re-trigger or fixed modes.

With this switch OFF, the re-trigger mode is selected. In the re-trigger mode, the relay timer is restarted with the time programmed (with switches 4, 5, and 6) whenever motion is detected. The relay will only de-activate when the time programmed expires without additional motion detected during the active period.

With this switch ON, the fixed mode is selected and the relay will deactivate at the expiration of the relay time programmed (with switches 4, 5, and 6) and additional motion detection during the active period has no effect. The unit is shipped with this switch OFF (re-trigger mode).

Switches 4, 5, and 6 – Relay Timer Setting: These switches control the relay timing: To set the relay timing, refer to the following table:

Switch			Relay Time (Seconds)
4	5	6	
OFF	OFF	OFF	0.5
OFF	OFF	ON	1
OFF	ON	OFF	2
OFF	ON	ON	4
ON	OFF	OFF	8
ON	OFF	ON	16
ON	ON	OFF	32
ON	ON	ON	64

Switch 7 – Monitor Door Mode: This switch controls the Monitor Door Mode (normal or prevent). When this switch is OFF, the unit is set to the normal mode. In the normal mode the unit follows the relay timer settings regardless of the condition of the door contact (if present). When the switch is ON, the unit is set to the prevent mode. In the prevent mode, if motion is detected and the door is not opened, the relay will de-activate after a maximum of 10 seconds, even if programmed for a longer period by switches 4, 5, and 6. If motion is detected and the door is opened then closed, the relay will de-activate after one second. This prevents unauthorized people from entering.

NOTE: To use the prevent mode, you must have a door contact (Door Status Monitor) connected to the D (door) input of the unit.

Switch 8 – Fail Safe/Secure Mode: When in the Fail Safe mode (switch OFF), the lock control relay contacts are in the same condition when motion is detected or power is off. This removes power from the lock when motion is detected, a sensor fails, or on a power failure. In the Fail Secure mode (switch ON), the relay is in the same condition when no motion is detected or power is off. The Fail Secure mode will not signal the system or unlock the door on a sensor or power failure.

CAUTION: The user must get authorization to use the Fail Secure mode from their local authority.

9. Sounder and Adjusting Sounder Volume

The IS-320 contains a sounder with volume control. The sounder volume is adjustable from 10% (volume control set fully counter-clock-wise) to 100% (volume control set fully clock-wise). The sounder activates when:

- The S (sounder) input opens, if the S input is being used.
- The door is open during the last 10 seconds of the relay timer and thereafter if the D (door input) is being used and timer is set for 16 or more seconds.
- The door is opened without motion detection or reader activation if the D (door input) is being used. The sounder continues until the door is closed or motion is detected.

10. Walk Testing

Walk into the motion detection field. Two to four normal steps into the field should make the LED light.

NOTE: The IS-320 has a warm-up period of approximately 2 minutes.

Each time the LED goes on, wait for it to go off. Then wait 12 seconds before continuing the walk-test. When there is no motion in the detection field, the LED should be off.

IMPORTANT: Test the IS-320 at least once a year.

11. Specifications

- Range:**
 Long: 8.4' x 15.8' (Adjustable)
 2.6m x 4.8m (Adjustable)
 Short: 2' x 5.5' (Adjustable)
 0.5m x 1.7m (Adjustable)
- RFI Immunity:**
 30 V/m, 1 MHz – 1000 MHz
- White Light Immunity:**
 2000 Lux
- Size:**
 Form C
 17.8cm x 5.1cm x 5.1cm
- Relay (Dual):**
 Contact rating; 1A max. at 30 VDC max.
- Sounder:**
 60 dB @ 10' (3.05m)
- Tamper Switch:**
 Closed with cover in place
 Contact rating 100mA @30 VDC
- Part Numbers:**
 IS-320WH – White Housing
 IS-320BL – Black Housing
- Power Requirements:**
 12 to 28 VDC or VAC
 3V peak-to-peak @ 12.5V
 <70 mA current consumption
- White Light Immunity:**
 2000 Lux
- Accessories:**
 IS-320WHTP – Single gang trim plate, White
 IS-320BLTP – Single gang trim plate, Black
- Operating Temperature:**
 32° to 122°F (0° to 50°C)
- Relative Humidity:**
 <95% non-condensing

12. Regulatory Notices

The IS-320 fully complies with the following regulations:

- FCC Part 15
- UL 294 – Access Control System Units
- C22.2 No. 205-M1983 – Signal Equipment
- CE

