

STI Select-Alert

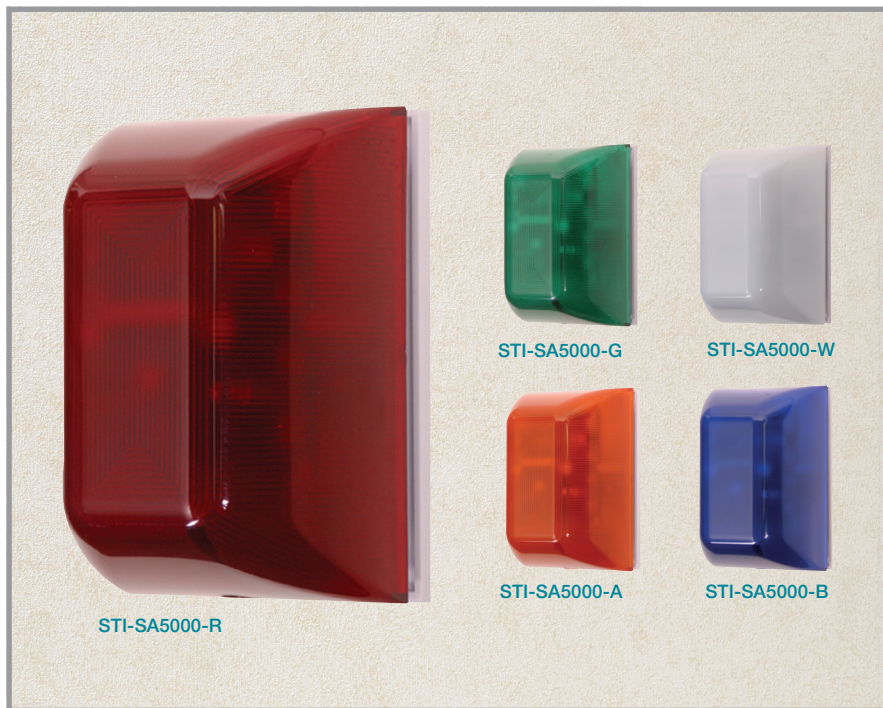

PRODUCT OVERVIEW

This controller helps prevent unauthorised use of important devices. The STI Select-Alert is a highly effective way to alert you to unauthorised use, theft or vandalism of important devices. The combination of alarm and super bright LEDs also offers excellent protection for an array of circumstances and allows the user to choose its function. Select-Alert can be used as a cabinet alarm, door/exit alarm, flashing light linked with a push button/switch, tornado siren, burglar alarm or an alert for any type of emergency situation.

HOW IT WORKS

If the protected unit is opened, the electronic Select-Alert emits a selected ear piercing siren and the LEDs flash – drawing attention in a hurry. The alarm and strobe have independent timing choices of: 15 seconds, 30 seconds, 60 seconds or continuous. Select-Alert can be powered by a 9 VDC battery or external 12-30 volts. Flush or surface mounted Select-Alert is available in amber, green, blue, red or white.

KEY FEATURES

General Information

- This controller helps prevent unauthorised use of important devices.
- Three year guarantee against breakage of polycarbonate in normal use (one year on electromechanical and electronic components).

Design

- Both a visual and audible alarm, it can serve as an inexpensive way to protect valuable units against theft and vandalism.
- Can be used as a cabinet alarm, door alarm, linked with push button/switch or as a burglar alarm.

Construction

- Polycarbonate is UV-stabilized.

Installation

- Highly versatile, includes a tamper switch which prevents it from being removed from a wall.

Electronics

- 9 VDC battery or external 12 - 30 volts input power options, allows independent strobe and siren timing of 15 seconds, 30 seconds, 60 seconds or continuous. One Form "C" dry relay contact output.

Options

- Additional white mounting plate with key switch or white 40mm back box.
- May be set for a piercing 100 dB alarm or a softer 85 dB.
- Super bright flashing LED.
- Low battery indicator.



For more information, call +44 (0)1527 520 999 or visit www.sti-europe.com



**Safety Technology
International**

STI Select-Alert

Dimensions and Technical Information

MODELS AVAILABLE

- STI-SA5000-A** Select-Alert in amber
- STI-SA5000-B** Select-Alert in blue
- STI-SA5000-G** Select-Alert in green
- STI-SA5000-R** Select-Alert in red
- STI-SA5000-W** Select-Alert in white

Accessories:

- SUB SA504** Back box kit
- 18075** Replacement key for Select-Alert alarm
- 18151** N.C. reed switch and magnet
- SUB SA505** Key switch mounting bracket (includes key switch)
- BAT 9VDC** 9 volt battery

SPECIFICATIONS

Operating voltage	Internal 9 VDC battery (not included) Remote power 12-30 VDC
Power Consumption	Stand by: 50µA Siren low volume: 85mA Siren high volume: 90mA Strobe: 25mA
Siren Volume	Low: 85 dB High: 100 dB
Alarm & Strobe Timing	Independent control for siren and strobe: 15s, 30s, 60s and continuous
Low Battery Warning	LEDs flash once every 30 seconds
Form C dry contacts	0-30VAC/DC, 1 Amp Contacts reset after longest alarm setting
Key switch	Alarm on: normally closed
Alarm switch	Stand by: normally open contact required
Alarm tone	32 selectable sounds

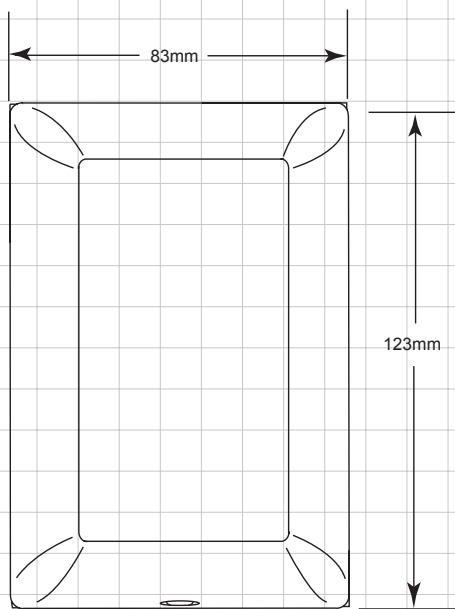

SA5000 Front View

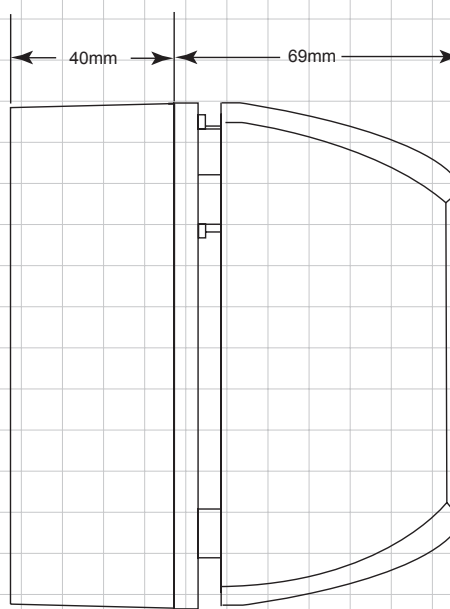

SA5000 Side View



Safety Technology International

UK Office
Unit 49G Pipers Road
Park Farm Industrial Estate
Redditch, Worcestershire
B98 0HU, England

Tel: +44 (0)1527 520 999
Fax: +44 (0)1527 501 999
info@sti-europe.com
www.sti-europe.com

USA Head Office
2306 Airport Road
Waterford, Michigan
48327 - 1209

Tel: +248-673-9898
Fax: +248-673-1246
Toll-free: 0800-888-4STI
info@sti-usa.com
www.sti-usa.com