



► VisiBeam® II Spotlight

FEATURES

- Brilliant work area lighting.
- Handheld control unit.
- “Graduated start” for pinpoint accuracy.
- Energy efficient.
- 360° Rotation capability.
- Horizontally and vertically adjustable.
- Twist-off dome for easy maintenance.

For effective work area illumination, Federal Signal’s VisiBeam® II high power spotlight features a handheld remote control head with pinpoint accuracy.

The spotlight uses the combination of a highly polished parabolic reflector and halogen bulb to produce a clear, even lightbeam that exceeds both “spot” and “flood” sealed beams. When operating, this powerful light is also energy efficient. The 55-watt version draws only 4.2-amps.

The VisiBeam II spotlight assembly is adjustable upward 105° and downward 35° from horizontal, and it can rotate a complete 360°. For pinpoint placement of the lightbeam, the assembly moves gradually at first and then increases speed to the target. This “graduated start” enables the user to move the light in small increments.

The VisiBeam II’s compact remote control head can be operated from the palm of your hand or mounted on the vehicle’s dash. This is a great alternative to bulky manual spotlight controls in the cab of the vehicle. Also, an indicator light on the control reminds the user that the spotlight is on.

Installation is quick and easy. The compact control head fits virtually anywhere and can be mounted with Velcro® or a more secure “snap holder” (both are included). The VisiBeam II control head is connected to the light via a 15’ “telephone” type cable. Each VisiBeam II is available with a choice of three mounting options: permanent, magnetic, or pipe mount.

Specify model

620102	VB12S, 55-watt halogen spotlight assembly with permanent mount kit
620122	VB12S1, 100-watt halogen spotlight assembly with permanent mount kit
VB24S	65-watt, 24V halogen spotlight assembly with permanent mount kit
620132	VB12M, 55-watt halogen spotlight assembly with magnetic mount and cigarette lighter plug with 10' cord
620142	VB12M1, 100-watt halogen spotlight assembly with magnetic mount and cigarette lighter plug with 10' cord
620152	VB12P1, 100-watt halogen spotlight assembly with pipe mount kit

	55W VisiBeam II	65W VisiBeam II	100W VisiBeam II
Specifications			
Volts	12V	24V	12V
Current Draw	4.2A @12.8V	2.7A @ 24.0V	7.8A @ 12.8V
Physical Specifications			
	Height	Diameter	Ship. Weight
620102	6.5 in (16.5 cm)	6.5 in (16.5 cm)	2.0 lbs (0.9 kg)
620122	6.5 in (16.5 cm)	6.5 in (16.5 cm)	2.0 lbs (0.9 kg)
VB24S	6.5 in (16.5 cm)	6.5 in (16.5 cm)	2.0 lbs (0.9 kg)
620132	6.9 in (17.5 cm)	6.5 in (16.5 cm)	2.0 lbs (0.9 kg)
620142	6.9 in (17.5 cm)	6.5 in (16.5 cm)	2.0 lbs (0.9 kg)
620152	7.3 in (18.4 cm)	6.5 in (16.5 cm)	2.0 lbs (0.9 kg)

Mounting Diagram

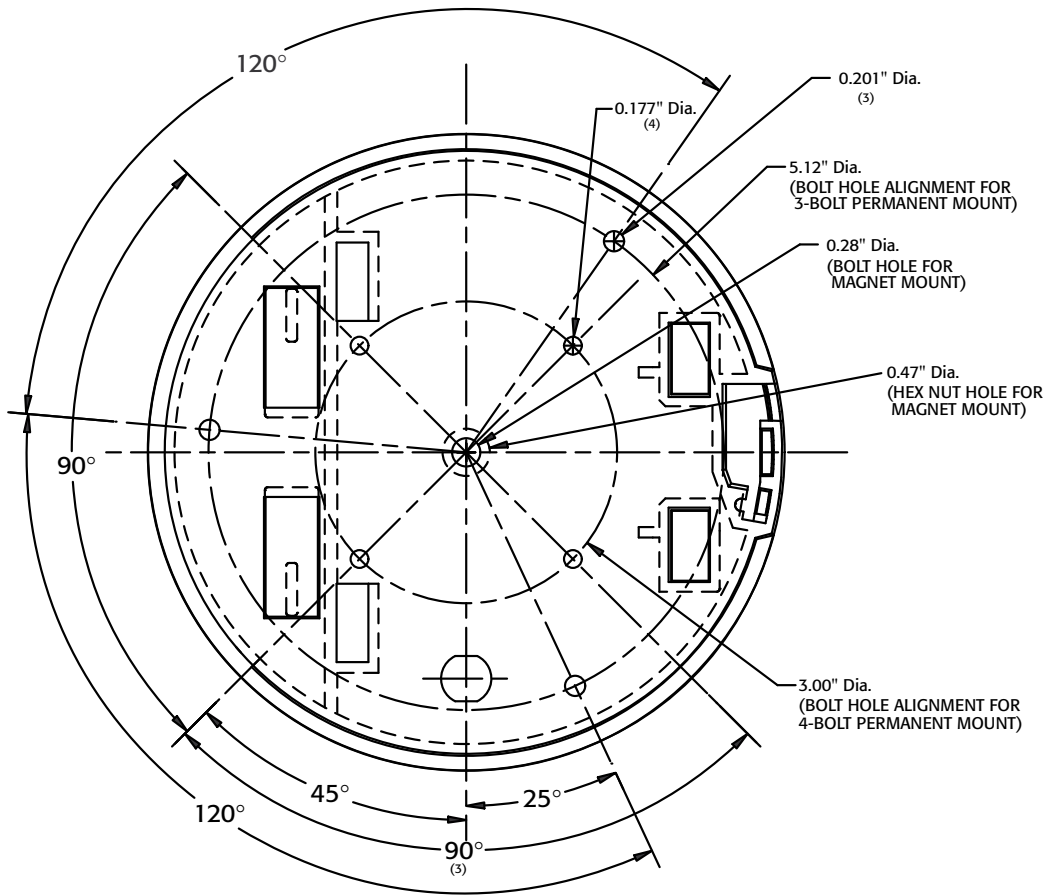

VisiBeam and Night-Fighter are trademarks of Federal Signal Corporation.
 Littlite is a registered trademark of CAE, Inc.
 Velcro is a trademark of Velcro IndustriesB.V.

