

# HCA Series

## Conventional Fire Alarm System

(HCA-2, HCA-2D, HCA-4, HCA-4D, HCA-8, HCA-8D)  
Installation and Operation Manual



Hochiki America Corporation  
7051 Village Drive, Suite 100  
Buena Park, CA90621-2268  
714.522.2246 Corporate Headquarters  
800.845.6692 Technical Support  
<http://www.hochiki.com>

Version 2.09  
Created: 12/18/2012  
HA-06-266

# Table of Contents

- 1. Introduction..... 5
  - 1.1 *Product Features*..... 5
  - 1.2 *Electrical Specifications*..... 6
  - 1.3 *Fire Alarm System Limitations*..... 7
  - 1.4 *Installation Precautions*..... 8
- 2. Controls and Indicators ..... 10
  - 2.1 *Front Panel User Control Buttons*..... 10
  - 2.2 *LED Indicators:* ..... 10
  - 2.3 *Local Piezoelectric (PZT) Sounder:* ..... 11
- 3. Control Panel Installation..... 12
  - 3.1 *Agency Requirements*..... 12
  - 3.2 *Requirements for All Installations*..... 12
  - 3.3 *Calculating Current Draw and Battery Size*..... 13
    - 3.3.1 *Maximum Battery Standby Load*..... 13
    - 3.3.2 *Calculating Maximum Current Draw & Battery Backup Requirements*..... 13
  - 3.4 *Mounting the Enclosure* ..... 15
  - 3.5 *AC Power Connection* ..... 15
  - 3.6 *Battery Installation*..... 16
  - 3.7 *NAC Output Circuit Installation* ..... 17
  - 3.8 *Zone Installation* ..... 18
  - 3.9 *Inner Door Label (Wiring Diagram)*..... 19
  - 3.10 *Relay Outputs*..... 20
  - 3.11 *DACT Phone Lines*..... 21
  - 3.12 *Remote Annunciator (Model HCA-RA)*..... 22
    - 3.12.1 *HCA-RA Installation* ..... 22
    - 3.12.2 *HCA-RA Specifications* ..... 23
  - 3.13 *Diagnostic LEDs* ..... 24
- 4. Control Panel Operations ..... 25
  - 4.1 *LCD Display Screens*..... 25
    - 4.1.1 *Initial Display Screen after System Initialization and Panel Revision* ..... 25
    - 4.1.2 *System Normal Status Screen* ..... 26
    - 4.1.3 *Off Normal System Status Screens and Sounds* ..... 26
    - 4.1.4 *Zone Alarm and/or Trouble Screens* ..... 26
    - 4.1.5 *System TROUBLE Screens* ..... 26
    - 4.1.6 *NAC Output Trouble Screens*..... 27
    - 4.1.7 *Multiple Trouble Screens*..... 27
    - 4.1.8 *Active Alarms and Trouble Screens* ..... 27
  - 4.2 *Operation Keys* ..... 28

4.2.1	System Reset .....	28
4.2.2	System Silence.....	28
4.2.3	System Acknowledge .....	28
4.3	<i>Login Screen</i> .....	28
4.3.1	Default Access Codes .....	28
4.4	<i>User Top Level Menu Options</i> .....	28
4.5	<i>Installer Top Level Menu Options</i> .....	29
4.6	<i>Fire Drill</i> .....	30
4.7	<i>Date/Time Setup</i> .....	30
4.8	<i>Walk Test</i> .....	31
4.9	<i>Event History</i> .....	31
4.9.1	Viewing Event History .....	31
4.9.2	Clearing Event History.....	32
4.10	<i>Disabling Circuits</i> .....	32
4.10.1	Disabling or Enabling Zones .....	32
4.10.2	Disabling or Enabling Outputs .....	33
4.11	<i>Manual DACT test</i> .....	33
4.12	<i>Operating the Remote Annunciator</i> .....	33
5.	Programming .....	34
5.1	<i>Editing User and Installer Access Codes</i> .....	34
5.2	<i>Zone Programming Options</i> .....	34
5.2.1	Zone Edit .....	34
5.2.2	Shorted Zone Mode.....	35
5.3	<i>Output Circuits and Relay Programming</i> .....	36
5.3.1	Reserved .....	36
5.3.2	NAC Output circuits.....	36
5.3.3	Relay Silencing Programming.....	38
5.3.4	Cadence Pattern Programming.....	38
5.4	<i>Releasing Programming Options</i> .....	39
5.4.1	Agent Releasing .....	39
5.4.2	Water Releasing.....	42
5.4.3	How to Install the Disconnect Switch on the Releasing Circuit.....	45
5.5	<i>Remote Annunciator</i> .....	47
5.6	<i>DACT Setup</i> .....	47
5.6.1	Enable/Disable the DACT .....	47
5.6.2	Auto Test Time of Day.....	47
5.6.3	Low AC Reporting Delay .....	48
5.6.4	Edit Accounts.....	48
5.6.5	Edit Phone Lines .....	51
5.7	<i>Panel Factory Default Setup</i> .....	52
5.7.1	Factory Default Settings .....	52
6.	DACT Reporting Codes and Compatible Receivers .....	53
6.1	<i>DACT Reporting Codes for SIA and Contact ID</i> .....	53

7. Compatible Devices for the HCA Series Panel.....	54
7.1 <i>Compatible Conventional Initiating Devices</i> .....	54
7.2 <i>Compatible Releasing Devices</i> .....	54
7.3 <i>Compatible Heat Detector Cable</i> .....	55
7.4 <i>Compatible Notification Appliances</i> .....	55
8. Warranty .....	56

## 1. Introduction

The HCA series fire alarm control panels provide all of the sophisticated features required of a leading edge conventional fire alarm system along with the simple operation and efficient installation methods demanded by both installers and building users.

The panel can be flush or surface mounted and the generously sized metal back box allows ample space for rear or top cable entries.

A comprehensive range of auxiliary devices is available to operate with the HCA series control panels including optical, ionization, photoelectric, photoelectric-thermal and heat detectors.

Each of the HCA series system components has been specifically designed to operate as part of the HCA series system. This provides assurance that the control panel, smoke detectors, interface devices and the ancillary components are all fully compatible with one another and that the full range of system functionality is supported by each device.

### 1.1 Product Features

The HCA panels have the following key features:

- 2, 4, or 8 conventional input zones (Models HCA-2, HCA2-D, HCA-4, HCA-4D, HCA-8, HCA-8D).
- Built-in Digital Alarm Communicator Transmitter (DACT) included with models HCA-2D, HCA-4D, HCA-8D.
- 4 notification appliance circuits (NAC) with built-in synchronization for ANSI 3.41 and Gentex.
- All 6 models come with a 6.5 amp power supply.
- Optional Remote Annunciator available – Model HCA-RA
- Agent and Water Releasing Support.
- Dedicated alarm and trouble relays.
- 3 programmable general purpose relays in addition to alarm and trouble.
- Built-in two line 32 character LCD display provides large easy to read text.
- 15 key keypad for panel operations and programming.
- Event History Buffer (255 events) with Date/Time stamp. Events can be displayed on LCD.
- Real time clock.
- Built-in walk test.
- Housed in a 14.6"W x 15.6"H x 4.53"D metal enclosure.
- Enclosure supports two 12V, 7Ah backup batteries.

## 1.2 Electrical Specifications

Table 1 - Electrical Specifications

Primary AC	120VAC 50/60 Hz or 240VAC 50/60 Hz
Power supply rating	6.5 Amps @ 24VDC (All Models)
Maximum Battery Charging Current	0.98 Amps @ 22VDC
Maximum Battery Charger Capacity	18 Ah battery (Two 7 Ah batteries fit inside cabinet)
Initiating Device Circuits HCA-2	Alarm Zone 1 & 2
Initiating Device Circuits HCA-4	Alarm Zone 1, 2, 3, & 4
Initiating Device Circuits HCA-8	Alarm Zone 1, 2, 3, 4, 5, 6, 7, & 8
Initiating Wiring Style	Class B (Style B and C)
Normal Initiating Operating Voltage	23VDC, Maximum 25.5VDC, regulated
Short Circuit Initiating Current (per zone)	48mA Maximum
Maximum Initiating Resistance (per zone)	10 ohms
Initiating End-of-Line Resistor	4.7K ohms 1/2W 5%, 0400-01820
Standby Detector Current (per zone)	4mA maximum
Maximum Detector Count (per zone)	20 detectors
Initiating Cabling Type	18AWG Twisted Shielded pair (14 – 18 AWG)
Detector Base Impedance	430 ohms
Notification Appliance Circuits	4 NACs, Special Application
Maximum NAC Current Rating	2.5 Amp maximum per circuit
Total NAC Signaling Current	6.2 Amps total with 6.5 Amp supply
NAC Wiring Style	Class B (Style Y)
NAC Operating Voltage	24VDC Nominal, 27VDC Maximum
NAC Line Impedance Maximum	1.5 volt line drop maximum
NAC End-of-line Resistor	10.0K ohms 1/2W 5%, 0400-01046 (0400-02590 for releasing application)
NAC Sync Protocols	Continuous On, Gentex, ANSI 3.41 Temporal, March
Trouble Relay rating	3A & 30VDC, 1.0pf
Alarm Relay rating	3A & 30VDC, 1.0pf
Relay 1 (programmable)	3A & 30VDC, 1.0pf
Relay 2 (programmable)	3A & 30VDC, 1.0pf
Relay 3 (programmable)	3A & 30VDC, 1.0pf

### 1.3 Fire Alarm System Limitations

An automatic fire alarm system – in general is made up of smoke detectors, heat detectors, manual pull stations, call points, audible warning devices, and fire alarm control panels with remote notification capability, which can supply early warning of a developing fire. Such a system, on the other hand, is unable to assure protection against property damage or loss of life resulting from a fire.

The manufacturer recommends that smoke and /or heat detectors must be positioned throughout a protected premise following the recommendations of the current edition of the National Fire Protection Association Standard 72 (NFPA 72), manufacturer's recommendations contained in the Guide for proper Use of System Smoke Detectors, which is made available at no charge to all installing dealers. A study by the Federal Emergency Management Agency (an agency of the United States government) indicated that smoke detectors may not go off in as many as 35% of all fires. A fire alarm system may not provide timely or sufficient notice, or might not function, for a diversity of reasons:

**Smoke detectors** may not sense fire where smoke cannot reach the detectors such as in chimneys, in or behind walls, on roofs, or on the other side of closed doors. Smoke detectors also may not sense a fire on another level or floor of a building. A second-floor detector, for example, may not sense a first-floor or basement fire.

**Particles or combustion or "smoke"** from a developing fire may not reach the sensing chambers of smoke detectors because:

- Barriers such as closed or partially closed doors, walls, or chimneys may inhibit particle or smoke flow.
- Smoke particles may become "cold," stratify, and not reach the ceiling or upper walls where detectors are located.
- Smoke particles may be blown away from detectors by air outlets.
- Smoke particles may be drawn into air returns before reaching the detector.

The amount of "smoke" present may be insufficient to alarm the smoke detectors. Smoke detectors are designed to alarm at various levels of smoke density. If such density levels are not created by a developing fire at the location of detectors, the detectors will not go into alarm. Smoke detectors, even when working properly, have sensing limitations. Detectors that have photo electronic sensing chambers tend to detect smoldering fires better than flaming fires, which have little visible smoke. Detectors that have ionizing-type sensing chambers tend to detect fast-flaming fires better than smoldering fires. Because fires develop in different ways and are often unpredictable in their growth, both types of detectors are necessarily best and a given type of detector may not provide adequate warning of a fire. A smoke detector cannot be expected to provide adequate warning of fires caused by arson, children playing with matches (especially in bedrooms), smoking in bed, and violent explosions (caused by escaping gas, improper storage of flammable materials, etc.). Heat detectors do not sense particles or combustion and alarm only when heat on their sensors increases at a preset rate or reaches a predetermined level. Rate-of-rise heat detectors may be subject to reduced sensitivity overtime. For this reason, the rate-of-rise feature of each detector should be tested at least once per year by a qualified fire protection expert. Heat detectors are designed to protect property, not life.

**IMPORTANT!** Smoke detectors must be installed in the same room as the control panel and in rooms used by the system for the connection of alarm transmission wiring, communications, signaling, and/or power. If detectors are not located near the control panel, a developing fire may damage the alarm system, crippling its ability to report a fire.

**Audible warning devices** such as bells may not alert people if these devices are located on the other side of closed or partly open doors or are located on another floor of a building. Any warning device may fail to alert people with a disability or those who have recently consumed drugs, alcohol or medication. Please note that:

- Strobes can, under certain circumstances, cause seizures in people with conditions such as epilepsy.

Studies have shown that certain people, even when they hear a fire alarm signal, do not respond or comprehend the meaning of the signal. It is the property owner's responsibility to conduct fire drills and other training exercise to make people aware of fire alarm signals and instruct them on the proper reaction to alarm signals.

In rare instances, the sounding of a warning device can cause temporary or permanent hearing loss.

**A fire alarm system** will not operate without any electrical power. If AC power fails, the system will operate from standby batteries only for a specified time and only if the batteries have been properly maintained and replaced regularly.

**Equipment used in the system** may not be technically compatible with the control. It is essential to use only equipment listed for service with your control panel.

**Telephone lines** needed to transmit alarm signals from a premise to a central monitoring station may be out of service or temporarily disabled. For added protection against telephone line failure, backup radio transmission systems are recommended.

**The most common cause** of fire alarm malfunction is insufficient maintenance. To keep the entire fire alarm system in excellent working order, on-going maintenance as required by the manufacturer's recommendations, UL and NFPA 72 shall be followed. Environments with large amounts of dust, dirt or high air velocity require more frequent maintenance. A maintenance agreement should be arranged through the local manufacturer's representative. Maintenance should be scheduled monthly or as required by National and/or local fire codes and should be performed by authorized professional fire alarm installers only. Adequate written records of all inspection should be kept.

## 1.4 Installation Precautions

**WARNING** – Several different sources of power can be connected to the fire alarm control panel. Disconnect all sources of power before servicing the control unit. Associated equipment may be damaged by removing and/or inserting cards, modules or interconnecting cables while the unit is energized. Do not attempt to install, service, or operate this unit until this manual is read and understood fully.

**CAUTION** – System Reacceptance Testing Requirements. To ensure proper system operation, this product must be tested in accordance with NFPA 72 after any programming operation or change in site specific software. Re-acceptance testing is required after any change, addition or deletion of system components, or after any modification, repair or adjustment to system hardware or wiring. All components, circuits, system operations, or software functions known to be affected by a change must be 100% tested. In addition, to ensure that other operations are not inadvertently affected, at least 10% of initiating devices that are not directly affected by the change, up to a maximum of 50 devices, must also be tested and proper system operation verified.

This system meets NFPA requirements for indoor dry operation at 0-49° C/32-120° F and at a relative humidity up to 93 ±2%RH (non-condensing) at 32 ±2° C/90 ±3° F. However, the useful life of the system's standby batteries and the electronic components may be adversely affected by extreme temperature ranges and humidity. Therefore, it is recommended that this system and all peripherals be installed in an environment with a nominal room temperature of 15-27°C/60-80° F.

Verify that wire sizes are adequate for all initiating and indicating device loops. Refer to the manual specifications section for maximum allowable I.R. drop from the specified device voltage.

Like all solid state electronic devices, this system may operate erratically or can be damaged when subjected to lightning-induced transients. Although no system is completely immune from lightning transients and interferences, proper grounding will reduce susceptibility. Overhead or outside aerial wiring is not recommended, due to an increased susceptibility to nearby lightning strikes. Consult with the Technical Services Department if any problems are anticipated or encountered.

Disconnect AC power and batteries prior to removing or inserting circuit boards. Failure to do so can damage circuits.

Make all cable entries from the sides or top of the enclosure using the knockouts provided. Route internal wiring around the outer edges of the enclosure, and verify that it will not interfere with battery, transformer, or printed circuit board locations and connections.

Do not tighten screw terminals more than 9 in-lbs. Over-tightening may damage threads, resulting in reduced terminal contact pressure and difficulty with screw terminal removal.

This system contains static-sensitive components. Always ground yourself with a proper wrist strap before handling any circuits so that static charges are removed from the body. Use static-suppressive packaging to protect electronic assemblies removed from the unit.

**Follow the instructions in the installation, operating, and programming manuals. These instructions must be followed to avoid damage to the control panel and associated equipment. FACP operation and reliability depend upon proper installation by authorized personnel.**

## 2. Controls and Indicators

### 2.1 Front Panel User Control Buttons

#### **Acknowledge**

This function, abbreviated "Ack" on the keypad, is used to acknowledge an off normal condition such as an alarm or trouble condition. The acknowledge function tells the panel that building personnel or emergency responders are aware of the alarm, trouble, or supervisory condition. Acknowledging the alarm or trouble condition also silences the panel's sounder (PZT).

#### **Alarm Silence**

This function, abbreviated "Silence" on the keypad, is also known as "audible silence". Depending on the configuration of the alarm system, this function will either silence the system's notification appliances completely, or will silence only the audible alarm, with strobe lights continuing to flash. Audible silence allows for easier communication amongst emergency responders while responding to an alarm while still leaving the visual appliances on to indicate there is still an active alarm.

#### **Reset**

This function will reset the panel after an alarm condition. All initiating devices are reset, and the panel is cleared of any alarm conditions. If an initiating device is still in alarm after the system is reset, such as a smoke detector continuing to sense smoke, or a manual pull station still in an activated position, another alarm will be initiated.

### 2.2 LED Indicators:

#### **AC Power Green LED**

When this indicator is lit, power is being provided to the system from the building's electrical system and not from the backup battery. When the AC power condition is low or completely gone, the trouble indicator comes on and the AC power indicator goes off. If the AC power indicator is lit without any other indicators also lit, then the system is in a normal standby condition. If no LEDs are lit, there is no power source feeding the panel.

#### **Alarm Red LED**

This Indicator is lit when an alarm condition exists in the system, initiated by smoke detectors, heat detectors, sprinkler flow switches, manual pull stations, manual call points, or other initiating devices. Along with the indicator on the panel, notification appliances such as horns and strobes are also activated, signaling a need to evacuate the building occupants. In an alarm condition, the fire alarm control panel indicates where the alarm originated. The alarm panel can be reset once the device which initiated the alarm is reset, such as returning the handle of a manual pull station to its normal position.

#### **Trouble Yellow LED**

When on steady or flashing, it means that a trouble condition exists on the panel. Trouble conditions are often activated by a contaminated smoke detector or an electrical problem within the system. Trouble conditions are also activated by a zone being disabled (disconnected from the system), low power on the backup battery, disabled notification appliance circuits, earth ground faults, shorted circuits or open circuits. The alarm panel's sounder will activate if a trouble condition exists. In a trouble condition, the panel displays the zone or devices causing the trouble condition. The trouble indicator goes out automatically when the situation causing the trouble condition is rectified or restores to normal.

#### **Silence Yellow LED**

The silence signal indicates that a trouble, supervisory or and/or alarm condition has been silenced by activating the silence key.

#### **Supervisory Yellow LED**

The supervisory signal indicates that a portion of the building's fire protection system has been disabled (such as a fire sprinkler control valve being closed and, consequentially, a sprinkler tamper switch being

activated), or, less frequently, that a lower priority initiating device has been triggered (such as a duct smoke detector). The "Supervisory" indicator requires a "Reset" to clear.

### **2.3 Local Piezoelectric (PZT) Sounder:**

The piezoelectric sounder provides separate and distinct sounds for alarm, trouble, and supervisory conditions. The PZT sounds are as follows:

- Alarm – On for 1.25 seconds, Off for 0.25 seconds, repeat.
- Supervisory – On for 0.75 seconds, Off for 0.75 seconds, repeat.
- Trouble – On for 0.4 seconds, Off for 0.4 seconds, repeat.

### 3. Control Panel Installation

#### **Important, please read before proceeding!**

The equipment described in this manual is listed by ETL TESTING LABORATORIES for use in fire alarm signaling systems, only when installed in accordance with this manual and the latest National Fire Protection Association Standards NFPA 72; the National Electrical Code (NFPA 70); the Life Safety Code (NFPA 101); and/or the local authority having jurisdiction (AHJ). It is possible to apply system components incorrectly or arrange system components and installation wiring so that required life safety functions are NOT performed. As a result, lives may be lost.

To minimize this possibility:

- ✓ DO NOT deviate from any installation instructions contained in this manual.
- ✓ DO NOT assume any installation details not shown in this manual.
- ✓ DO NOT alter any mechanical or electrical features of the equipment supplied

BE FAMILIAR with the building code, fire prevention code, and/or requirements of the Authority Having Jurisdiction (AHJ) in the locale of the installation.

#### **!Caution!**

Under normal and fault conditions, AC line voltages may be present on any terminal. Touching any component could be hazardous and result in loss of life. A short circuit can result in arcing that could cause molten metal injuries to testing personal. To minimize this possibility, only qualified electrical technicians familiar with electrical hazards should perform these checkout procedures. Safety glasses should be worn by such personnel, and instruments used for voltage measurement should be designed for the purpose and should be in good mechanical and working order.

If there is application or installation information that is not clear or not covered in this manual, please contact us at: Hochiki America Corp. Technical Support, 1-800-845-6692 or by email: [technicalsupport@hochiki.com](mailto:technicalsupport@hochiki.com)

### 3.1 Agency Requirements

The PANEL is listed by ETL TESTING LABORATORIES to UL 864 9<sup>th</sup> edition as a FACP control unit for use in NFPA 72 systems.

### 3.2 Requirements for All Installations

General requirements are described in this section. When installing an individual device, refer to the specific section of the manual for additional requirements.

- All field wiring must be installed in accordance with NFPA 70 National Electric Code.
- Use UL listed smoke detectors and notification appliances compatible with the PANEL from those specified in Section 7 of this manual.
- A full system checkout must be performed every time the panel is programmed.

The HCA series of conventional fire alarm control panels are designed in accordance UL864 9<sup>th</sup> Edition, *Control Units and Accessories for Fire Alarm Systems*.

### 3.3 Calculating Current Draw and Battery Size

Use this section to determine the current draw and standby battery needs for your installation.

#### 3.3.1 Maximum Battery Standby Load

The nominal battery capacity versus system standby current is shown in table 3.3.1 for typical battery sizes. Make sure that the standby battery calculation of table 3.3.2 is less than the number of table 3.3.1 for the battery chosen and the standby hours needed.

**Table 3.3.1**

Battery Size	Maximum standby load with 5 minutes alarm, 24 hour standby	Maximum standby load with 5 minutes alarm, 60 hour standby
7AH	269mA	*
12AH	477mA	191mA
18AH	727mA	291mA

\* 7AH size is not capable of 60 hour standby.

#### 3.3.2 Calculating Maximum Current Draw & Battery Backup Requirements

Use table 3.3.2 to assist you in determining the worst case battery backup amp-hour requirements for the particular installation.

- 1) The known standby and alarm current draws for the panel are already filled in for table 3.3.2. Note that all EOL resistor currents for the zones and output circuits are already accounted for in the main panel current draw numbers and should not be included in the zone or output circuit currents.
- 2) Add in the total smoke detector standby current draw for each zone that is used and all standby accessory loads on output circuits configured as auxiliary power constant or auxiliary power resettable. Note that auxiliary power door holder current is not included for battery standby because it is powered down during battery backup. Put the appropriate current draw per device in the standby and alarm current boxes and record the total number of devices per zone or circuit in the "number of devices" column.
- 3) Add in all notification appliance alarm current draws for each output circuit configured as NAC.
- 4) Add up the total standby and alarm current draw values and record the totals in the appropriate boxes of table 3.3.2.
- 5) Multiply the standby and alarm currents with the standby and alarm hours to determine the total amp-hours needed for both standby and alarm. Add up the standby and alarm amp-hour results to get the total battery backup amp-hours required. Select a battery size that is at least 120% of the total amp-hours required to achieve a 20% safety margin for the battery backup.
- 6) Make sure the total standby and alarm current you calculated (including the current for the panel itself) does not exceed the 6.5 amps power supply rating. Also make sure you have not exceeded the maximum current per output circuit.

**Table 3.3.2 Worst Case Battery Current Calculations**

Devices	Number of Devices	Current per device	Standby Current	Alarm Current
	Multiply This Column	By This Column	To Get Standby/Alarm Currents	
<b>Main Panel</b>				
HCA Panel	1	Standby: 0.160A	0.160A	
		Alarm: 0.290A		0.290A
<b>Panel Relays</b>				
Alarm relay	1	Standby: 0.0A	0.0A	
		Alarm: 0.025A		0.025A
Trouble relay	1 (trouble relay OFF due to loss of AC)	Standby: 0.0A	0.0A	
		Alarm: 0.0A		0.0A
Relay 1		Standby: 0.0A	0.0A	
		Alarm: 0.025A		
Relay 2		Standby: 0.0A	0.0A	
		Alarm: 0.025A		
Relay 3		Standby: 0.0A	0.0A	
		Alarm: 0.025A		
<b>Remote Annunciator</b>				
Number of Remote Annunciators	(maximum 1)	Standby: 0.012A		
		Max Alarm: 0.030A		
<b>Zones</b>				
Number of Zone 1 Detectors		Standby:		
		Max Alarm: 0.040A		
Number of Zone 2 Detectors		Standby:		
		Max Alarm: 0.040A		
Number of Zone 3 Detectors		Standby:		
		Max Alarm: 0.040A		
Number of Zone 4 Detectors		Standby:		
		Max Alarm: 0.040A		
Number of Zone 5 Detectors		Standby:		
		Max Alarm: 0.040A		
Number of Zone 6 Detectors		Standby:		
		Max Alarm: 0.040A		
Number of Zone 7 Detectors		Standby:		
		Max Alarm: 0.040A		
Number of Zone 8 Detectors		Standby:		
		Max Alarm: 0.040A		
<b>Notification Appliances or Auxiliary Power Devices</b>				
Output 1		Standby:		
		Alarm:		
Output 2		Standby:		
		Alarm:		
Output 3		Standby:		
		Alarm:		
Output 4		Standby:		
		Alarm:		
<b>Total Worst Case Standby Current</b>			<b>A</b>	
<b>Total Worst Case Alarm Current</b>				<b>A</b>
<b>Number of Standby hours required (typically 24 hours)</b>			<b>H</b>	
<b>Number of Alarm hours required (5 minutes is 0.0833 hours)</b>				<b>H</b>
<b>Number of Standby amp-hours (standby amps X standby hours)</b>			<b>AH</b>	
<b>Number of Alarm amp-hours (alarm amps X alarm hours)</b>				<b>AH</b>
<b>Total battery amp hours required (add standby and alarm AHs)</b>				<b>AH</b>

### 3.4 Mounting the Enclosure

Install the enclosure as follows:

1. Carefully unpack the system components and inspect for any damage due to shipping.
2. Mount the enclosure in a clean, dry, vibration-free area where extreme temperatures are not encountered. The location should be readily accessible with sufficient room for easy installation and maintenance.
3. Mount the cabinet by using the two mounting holes located in the upper back of the cabinet. After the panel has been properly located using the mounting holes, the panel can be secured.
4. Complete all conduit connections to the cabinet. Use the knockouts provided in the top and the sides.

Wire must **NOT** enter the bottom of the cabinet, since this area is intended for batteries only.

### 3.5 AC Power Connection

#### WARNING!

To reduce the risk of electrical shock, make sure that all power has been turned off or disconnected prior to attempting to connect AC power to the Power Supply.

**Apply the AC Power BEFORE connecting the batteries to the Panel!**

Provide the Fire Alarm Control Panel with a dedicated AC Circuit rated 15 Amps or higher. Refer to figure 3.5 for the AC power wiring diagram.

1. Route the power cable into the cabinet via a left side knock out hole.
2. Attach the AC source live (hot) wire from the source to the terminal labeled "L".
3. Attach the AC source neutral wire from the source to the terminal labeled "N" terminal.
4. Attach the AC ground wire from the source to the terminal labeled  $\perp$

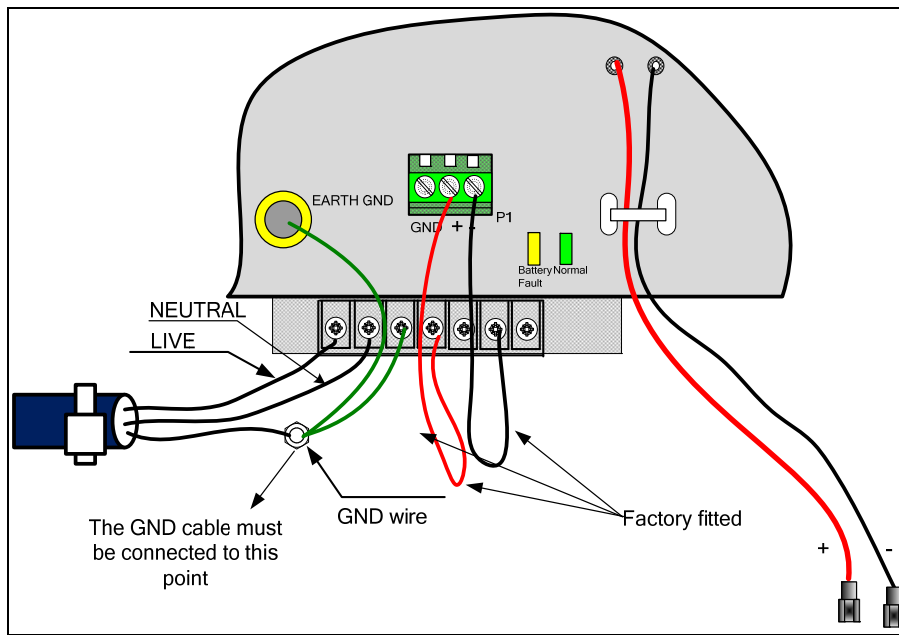

Figure 3.5 - AC Power Wiring Connection

### 3.6 Battery Installation

The batteries are placed at the bottom of the enclosure. The HCA panel is fully protected if the batteries are connected in the wrong polarity. The Amber battery fault LED on the main circuit board will show steady in such a condition. When the green battery LED is on steady it shows that the battery condition and connections are normal. See Figure 3.6 below.

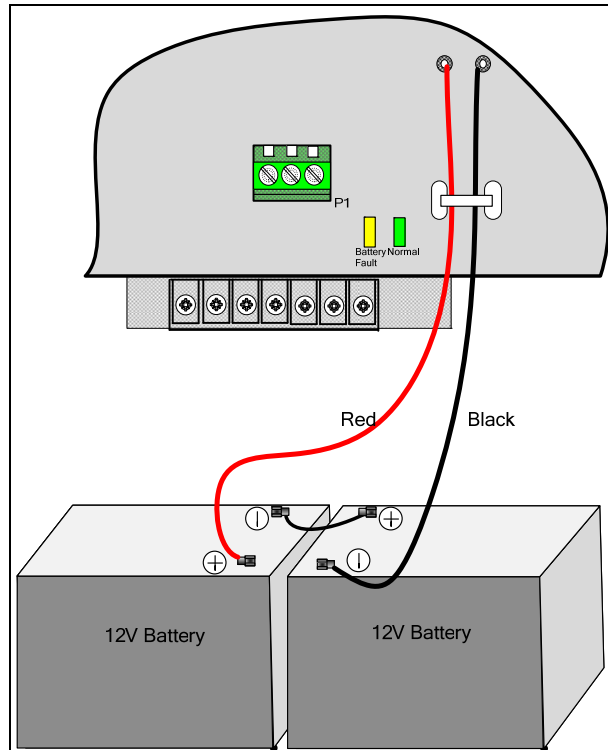
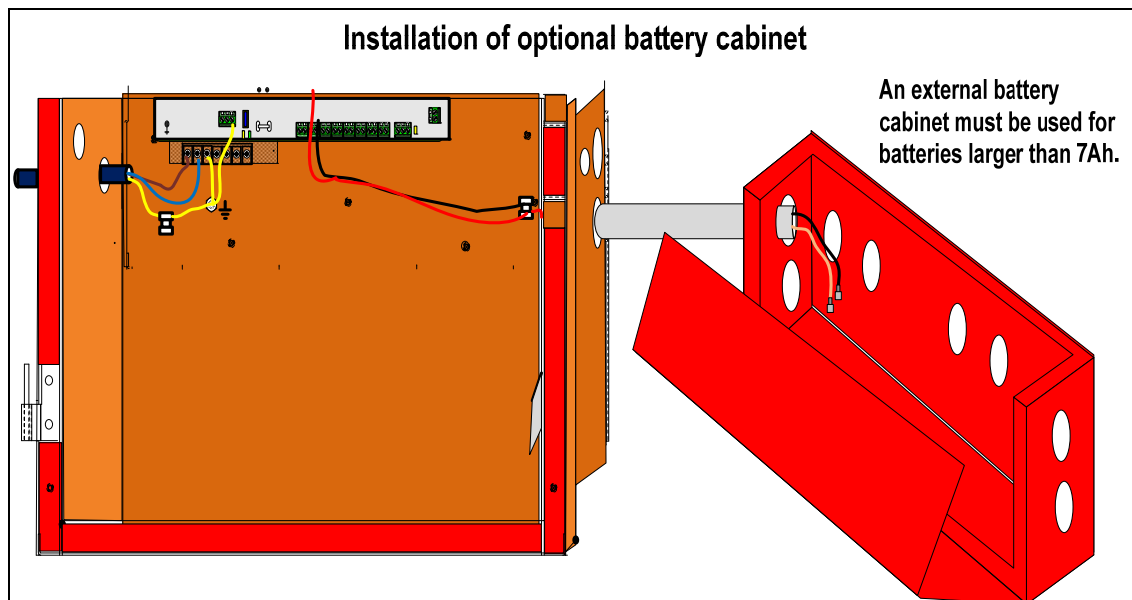

Figure 3.6 - Battery Connection to the HCA Control Panel



### 3.7 NAC Output Circuit Installation

The HCA series control panel has 4 built-in output circuits which can be individually configured as either class B (style Y) supervised notification appliance circuits (NACs), auxiliary power 24VDC circuits, auxiliary power 24V resettable circuits or auxiliary power 24V door holder circuits.

Figure 3.7 shows output circuit 1 wired as a class B NAC output. Observe the polarity of the wiring and the placement of the 10kΩ end of line (EOL) resistor located at the very end of the class B wiring. To wire an output as an auxiliary power circuit, observe the same polarity as shown in figure 3.7, but it is not a requirement to include the EOL resistor.

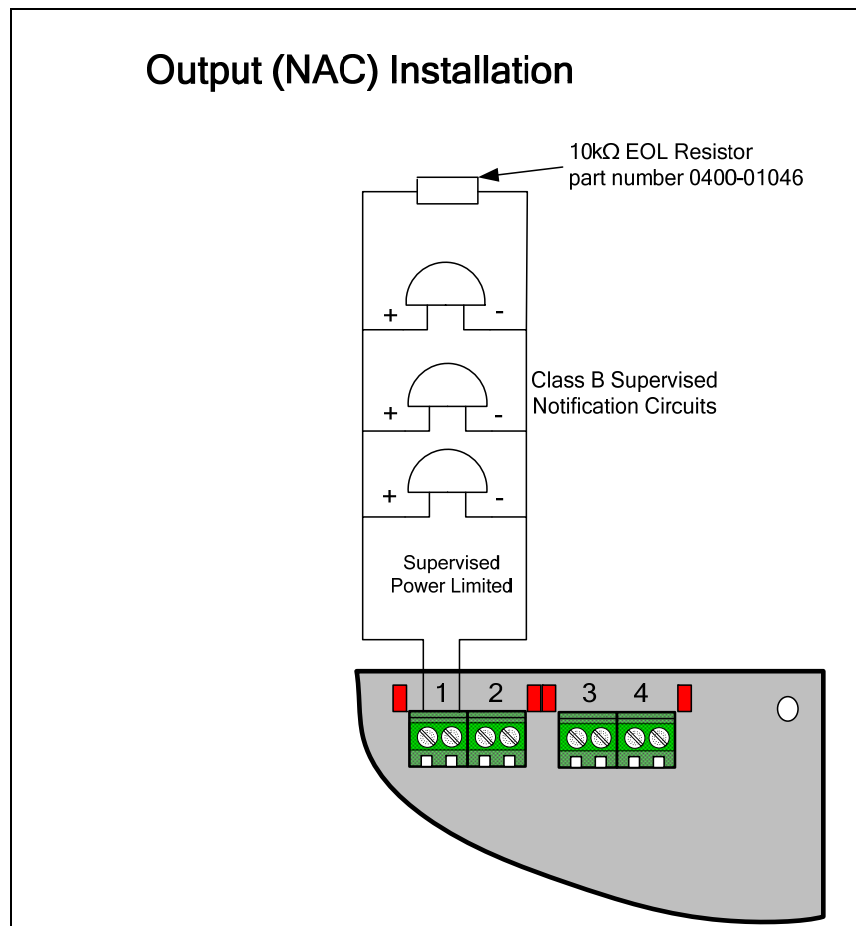

Figure 3.7- Supervised Notification Appliance Wiring

### 3.8 Zone Installation

The HCA series panel has either 2, 4 or 8 class B (style B or C) conventional input zones depending on the HCA model chosen. The mode programming option determines if the zone logic interprets short circuits as an alarm (style B) or a trouble condition (style C). Wire the smoke detector positive terminals to the HCA terminal labeled “+” and the negative smoke detector terminals to the HCA terminal labeled “-“ as shown in figure 3.8 which shows the HCA-8 panel. Each active zone requires a 4.7kΩ end of line (EOL) resistor at the very end of the zone as shown in figure 3.8.

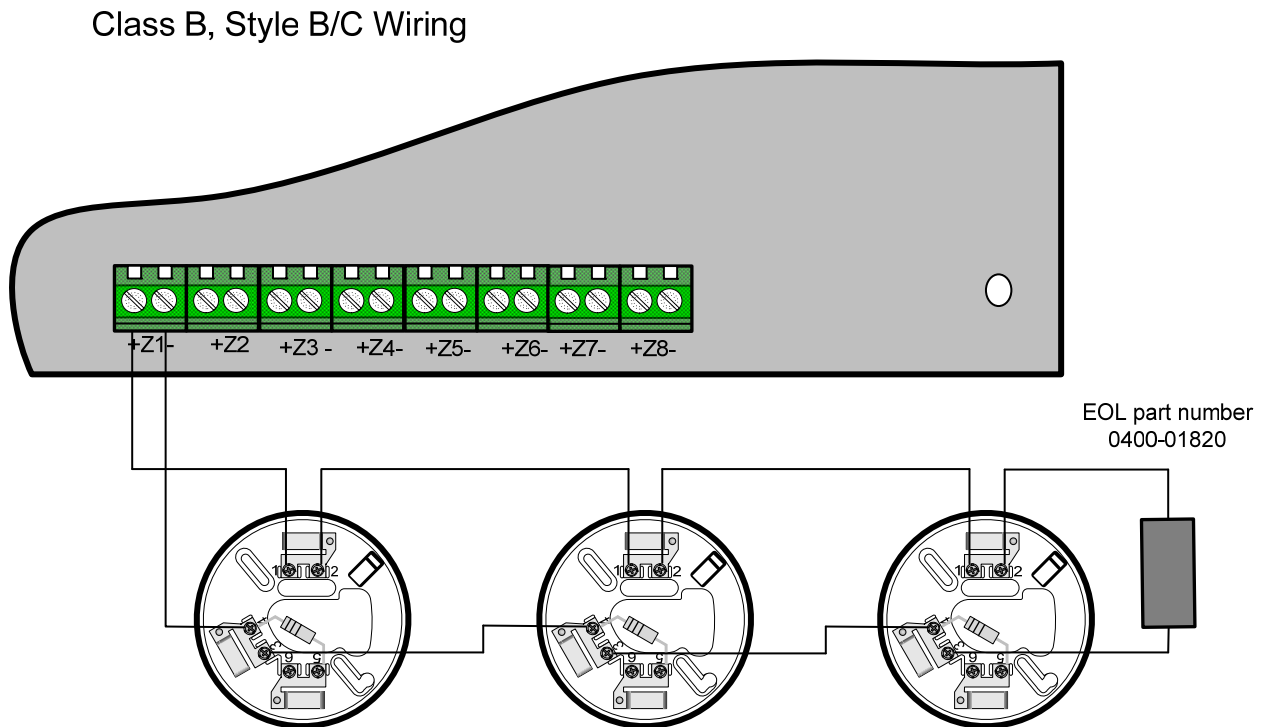
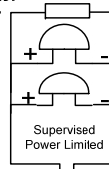

Figure 3.8 Zone Installation

### 3.9 Inner Door Label (Wiring Diagram)



10 KΩ resistor  
part number  
0400-01046



4 Class B Outputs:  
Special Application  
NAC, 2.5 amps max.  
Regulated Auxiliary  
Power, 1.0 amps max.

Conforms to UL864  
9<sup>th</sup> Edition



Install in accordance  
NFPA 72  
The HCA Series Panel  
is suitable as:  
Local signaling unit

All Circuits inherently  
power limited except  
AC / battery

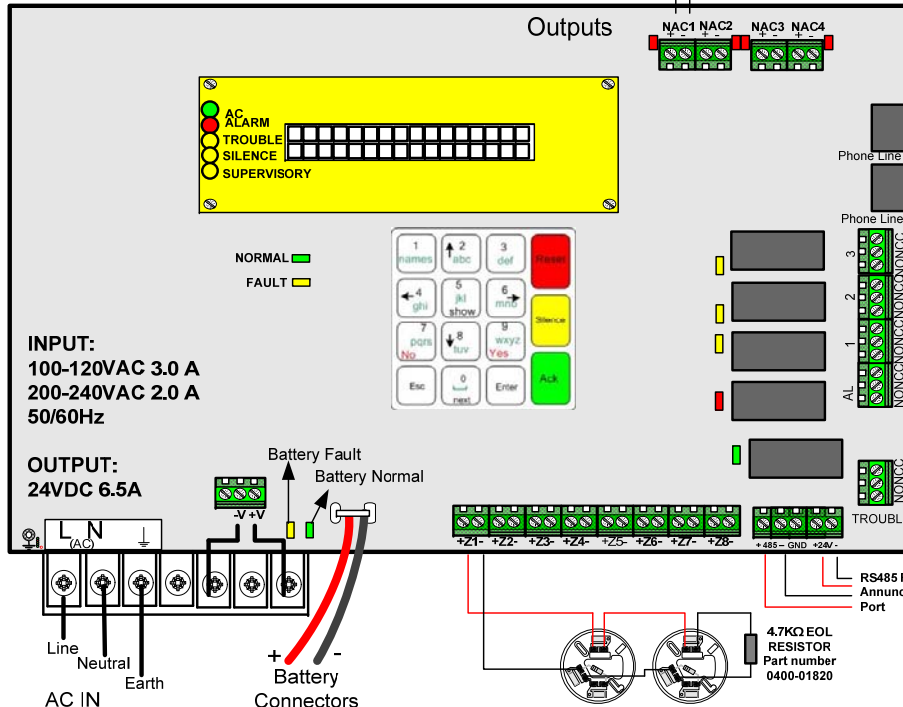

Optional Built-In DACT  
Phone Line Connections  
on HCA-2D, HCA-4D and  
HCA-8D models

Programmable Relays  
3 amps @ 30VDC  
(non supervised)

Alarm  
Relay  
3 amps @ 30VDC  
(non supervised)  
  
Trouble  
Relay

Refer to installation manual  
HA-06-266 section 6.1

Output circuit  
functions for  
Agent and Water  
Releasing  
applications

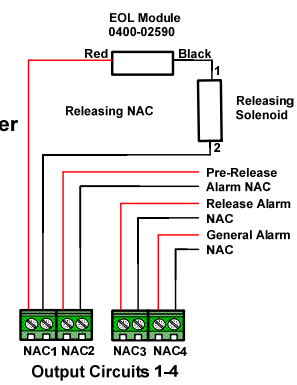

Compatibility identifier number: 0409007  
Software release: Version 2.XX  
Indoor use only (dry)  
Commercial – protected-premises control unit

**HCA SERIES WIRING DIAGRAM**  
P/N 1700-05660 Doc. HA-03-343 Rev. V2.XX DATE mm/dd/yyyy

**HOCHIKI AMERICA CORPORATION**  
This Product shall be installed  
in accordance with HCA Series  
Installation Manual: HA-06-266  
Version # 2.XX  
Issued: mm/dd/yyyy

### 3.10 Relay Outputs

Each HCA series panel has 5, form C relays. 2 of the relays are dedicated to common alarm and common trouble functions. The other 3 relays can be configured as Alarm or Supervisory functions. All 5 relay outputs (Alarm, Trouble, and the programmable relays) carry the same voltage and current ratings. The relays are rated 3 amps at 30VDC, power factor 0.4 - 1.0.

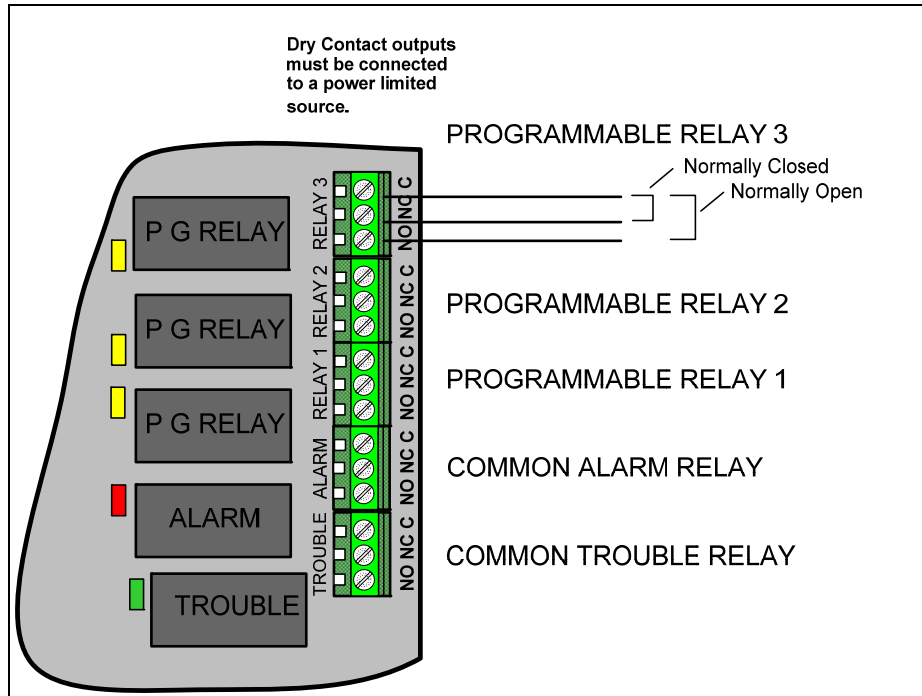

Figure 3.10- HCA Relay Outputs

### 3.11 DACT Phone Lines

Models HCA-2D, HCA-4D and HCA-8D have a built-in Digital Alarm Communicator Transmitter (DACT). These models have 2, RJ-45 phone line connectors used to wire the incoming telephone lines and pass through any local premises phone connections that are shared with the DACT. See figure 3.11 for wiring details.

**IMPORTANT:** The HCA DACT must be the first device connected on the incoming telephone lines and all local premises phones must be located on the phone wiring identified as Phone Ring and Phone Tip in the diagram below. Only direct connections to the Telco should be wired to the Telco Ring and Telco Tip in order for the DACT to be able to properly seize control of the telephone line when it needs to report.

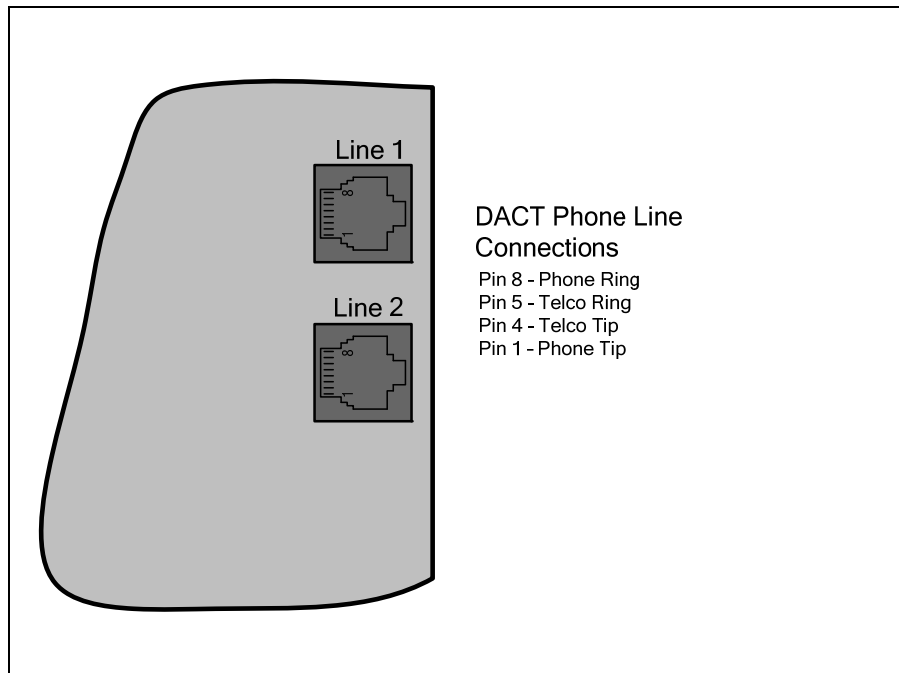

Figure 3.11–RJ-45 Phone Line Connectors

### 3.12 Remote Annunciator (Model HCA-RA)

#### 3.12.1 HCA-RA Installation

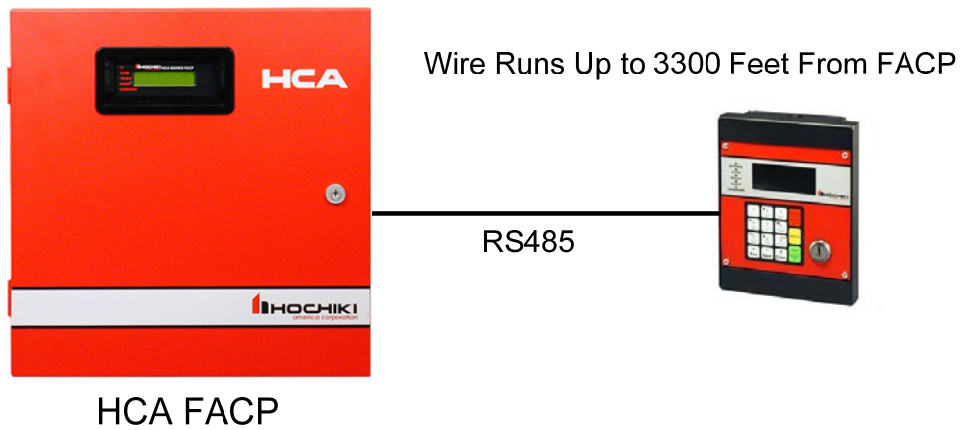
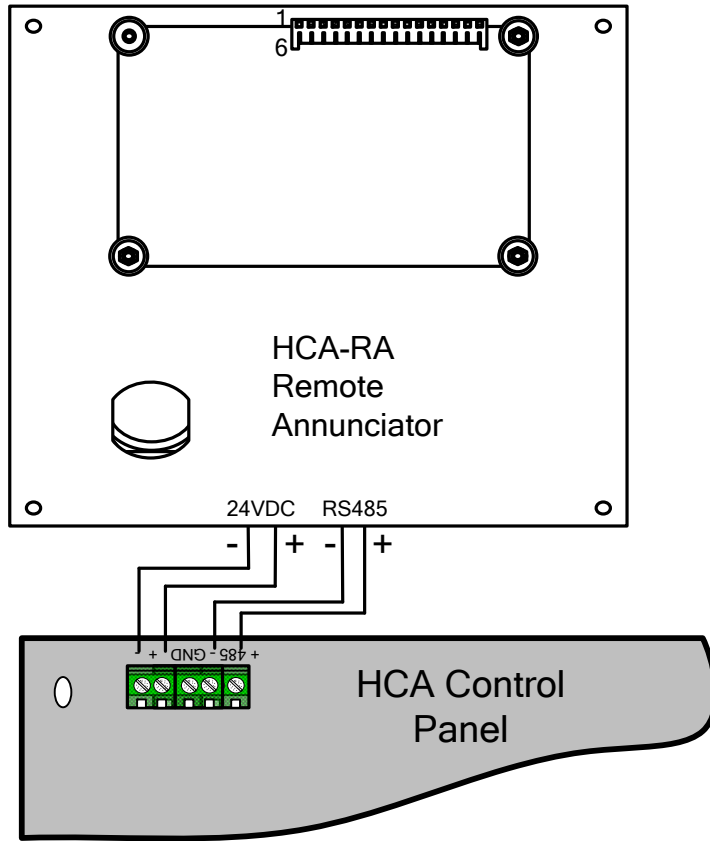

Figure 3.12 HCA-RA connections to the HCA panel.

It is necessary to enable the remote annunciator in the panel programming in order for the annunciator to function as intended. See programming section 5.5 of this manual for instructions on adding a remote annunciator to the HCA panel.

### 3.12.2 HCA-RA Specifications

#### Electrical Specifications

Operating Voltage: 16-26 VDC

Standby Current: 12 mA max

Alarm Current: 30 mA

Wiring Distance: 3,300ft max from FACP (using 18 gauge or larger diameter wire)

Maximum Annunciators Per System: 1

#### Environmental Specifications

Operating Temperature: 32°F –120°F (0°C – 49°C)

Humidity: 10% – 93% non-condensing

#### Approvals

ETL Listed

#### Compatibility

Compatible with HCA series fire alarm panels.

#### Physical Dimensions

160mm x 160mm x 44 mm (6.3in x 6.3in x 1.75in)

#### Features

- 64-character backlit LCD display (4 lines with 16 characters on each line)
- Membrane Keypad
- Accepts user codes or fire fighter's key
- Larger keypad buttons for system reset and silence
- RS-485 interface to panel
- On-board Piezo sounder audibly indicates alarms, troubles, and supervisories.
- Five status LEDs for alarm, supervisory, trouble, silence and AC power conditions
- Wiring lengths up to 3300 ft. from the FACP
- ETL listed, complies with NFPA 72



### 3.13 Diagnostic LEDs

The HCA panel contains various diagnostic LEDs that may be helpful when troubleshooting. Please refer to Figure 3.13 and the table below.

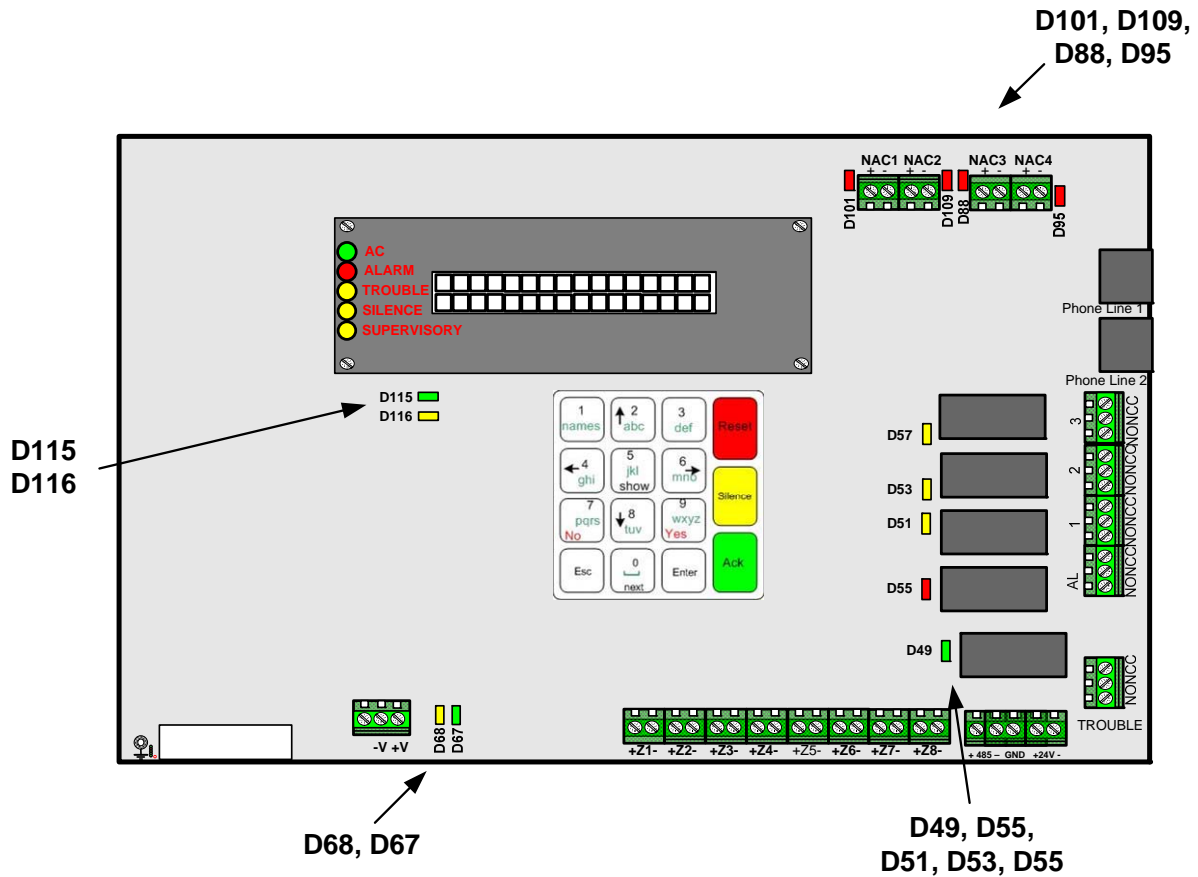

Figure 3.13 HCA Diagnostic LED Locations

Designation	Color	Description
D115	Green	This LED flickers when the panel is working normally.
D116	Amber	When this LED is lit, it indicates trouble with the panel's internal operation. Contact Hochiki Technical Support for assistance.
D67	Green	This LED is lit when the standby batteries are properly connected.
D68	Amber	This LED is lit if the standby battery polarity is reversed.
D101, D109, D88, D95	Red	These LEDs indicate the On/Off state of each of the four NACs.
D49	Green	This LED is lit when the Trouble is activated. <i>Note that the trouble relay is activated when the panel is normal and there are no troubles present.</i>
D55	Red	This LED is lit when the Alarm relay is activated.
D51, D53, D57	Amber	These LEDs are lit when the corresponding programmable relays are activated.

## 4. Control Panel Operations

All non-programming operations and system behaviors are described in this section. See section 5 for initial setup and control panel programming.

The HCA series control panel has 15 keys as shown in the diagram below that are used to operate and program the panel. Some of the keys have additional functions, which become active depending on the menu screen being displayed at the time.

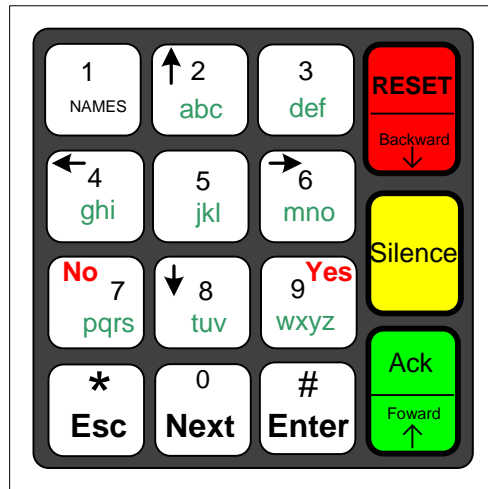

Figure 4 - HCA Control Panel Keypad

**Important Note:** If the system is left idle in a menu without any activity for 2 minutes, the system will reset itself.

### 4.1 LCD Display Screens

All status and operations display screens for the HCA panel are described below.

#### 4.1.1 Initial Display Screen after System Initialization and Panel Revision

The HCA control panel will only take a few seconds to initialize after the system is powered on. The first screen to be displayed will be the panel software revision which is displayed for about 10 seconds before the panel will display the system status idle screen. The software revision can also be displayed at any time by pressing the ACK key twice when the panel is idle. Pressing the ESC key with the software revision screen active will bring the panel back to the system status idle screen.

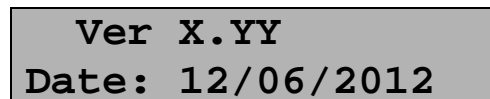

The X is the version number and the YY is the revision number.

#### 4.1.2 System Normal Status Screen

When the control panel condition is normal standby (no active alarms, troubles, etc.), it displays one of two system normal screens:

<b>16/03 13:17:03</b> <b>SYSTEM NORMAL</b>	European time and date format
---	-------------------------------

<b>03/16 01:17:03pm</b> <b>SYSTEM NORMAL</b>	American time and date format
---	-------------------------------

#### 4.1.3 Off Normal System Status Screens and Sounds

During off normal alarm, trouble, or supervisory conditions, the piezoelectric sounder provides separate and distinct sounds as follows:

- Alarm – On for 1.25 seconds, Off for 0.25 seconds, repeat.
- Supervisory – On for 0.75 seconds, Off for 0.75 seconds, repeat.
- Trouble – On for 0.4 seconds, Off for 0.4 seconds, repeat.

When alarms, supervisories and troubles are active at the same time, the alarm pattern is the highest priority, followed by supervisory and then trouble.

#### 4.1.4 Zone Alarm and/or Trouble Screens

The screen below is displayed when at least one zone is in trouble or alarm.

<b>Z1 2 3 4 5 6 7 8</b> <b>N A T N S D N A</b>	This screen is activated whenever an off normal condition exists for one or more zones. For any zone in alarm, the zone status letter will blink on and off.
---	--

The possible symbols appearing on the bottom line are:

- N zone enabled and operating correctly (normal standby)
- D zone disabled
- T zone enabled and in trouble condition
- S zone in supervisory condition
- A zone in non-release alarm condition
- P zone in pre-release alarm condition
- R zone in release alarm condition
- B indicates an Abort (Bypass) condition during an active release sequence countdown

#### 4.1.5 System TROUBLE Screens

The screens below are displayed during the following system trouble conditions:

<b>NO BATTERY</b>	This screen is displayed when there is no battery connected.
-------------------	--

<b>LOW BATTERY</b>	This screen is displayed when the battery is not fully charged.
--------------------	---

### **CHARGER FAULT**

This screen is displayed when the battery charger is not operating properly.

### **AC FAULT**

This screen is displayed when there is no AC power or the AC power is low.

### **GROUND FAULT**

This screen is displayed when there is an earth ground fault between at least one control panel circuit and earth ground.

### **Remote Panel err**

This screen is displayed when there is a problem communicating to the remote annunciator and the panel has been configured with the remote annunciator.

### **Account # Trbl**

This screen is displayed if the DACT fails to communicate to the central station. The account that failed will be indicated by a number, 1 – 4.

### **Phone Line # Trb**

This screen is displayed when one of the telephone lines have failed. The line that failed will be indicated by a number, 1 or 2.

#### **4.1.6 NAC Output Trouble Screens**

The screens below are displayed when one or more of the NAC outputs are in trouble. The output trouble type can be an open or shorted supervision trouble, or an over current circuit trouble.

### **NAC TROUBLE 1234**

The NAC TROUBLE screen is displayed when there are one or more NACs in trouble. In this example all 4 circuits are in trouble because all 4 circuits are displayed.

### **NAC TROUBLE 23**

In this example NACs 2 and 3 are in trouble. NACs 1 and 4 are normal.

#### **4.1.7 Multiple Trouble Screens**

When more than one trouble screen is active at the same time, each of the active screens will be alternately displayed every 2 seconds so that all of the off normal trouble screens can be viewed.

#### **4.1.8 Active Alarms and Trouble Screens**

When there is at least one active alarm and additional troubles that are not zone related, the zone alarm screen will be displayed every other screen no matter how many separate trouble screens are also active. Each of the active trouble screens will be displayed in a rotation with the zone alarm screen.

## 4.2 Operation Keys

### 4.2.1 System Reset

When there are active alarms and /or supervisories in the system, pressing the reset key will first silence all outputs and the panel's PZT while the zone input circuits are being reset. At the end of the reset period if there are no active alarms or supervisories the panel status will return to normal. If there are still active alarms or supervisories at the end of the reset period the panel will reactivate the PZT and outputs accordingly.

### 4.2.2 System Silence

Pressing the silence key when there is an off normal condition will silence the PZT and all active outputs that are configured as silenceable. Non-silenceable output circuits remain active until the panel is reset. The silence LED will be on to indicate the system has been silenced. If a new off normal condition occurs, the panel PZT and outputs will reactivate based on the condition of the panel and the silence LED will be off.

### 4.2.3 System Acknowledge

When there are off normal conditions in the system, the user can silence the panel PZT by pressing the acknowledge key. Acknowledge has no effect on any output circuits or system LEDs.

## 4.3 Login Screen

The login screen is activated whenever the user presses the Enter key while the system is in idle mode. The following screen will be displayed.

```
ENTER PASSWORD :  
-
```

Enter a valid 4 digit user or installer code. If the access code is invalid, the message "ACCESS DENIED" will be displayed for 2 seconds and the system display will return to the idle display. To log out of the system, press the Esc key.

### 4.3.1 Default Access Codes

The installer access code is factory defaulted to 3333.  
The user access code is factory defaulted to 2222.

## 4.4 User Top Level Menu Options

After entering the user access code the first user option is displayed as shown in the screen below.

```
USER MENU  
1-FireDrill, Nxt
```

Pressing 1 will select the fire drill function. The fire drill operates the same from the user or installer menu. Pressing the Next key will display the next user menu option.

```
USER MENU  
2-Date/Time, Nxt
```

Pressing 2 will select the editing of the date and time. The date and time adjustment is the same for both the user and installer menu. Pressing the Next key will display the next user menu option.

**USER MENU**  
**3-Walk Test, Nxt**

Pressing 3 will select the walk test function. The walk test function is the same for both the user and installer menus. Pressing the Next key will display the next user menu option.

**USER MENU**  
**4-EventHist, Nxt**

Pressing 4 will select event history display. The user menu is restricted to viewing event history. The installer menu allows the history to be cleared. Pressing the Next key will take the display back to option 1, Fire Drill.

#### 4.5 Installer Top Level Menu Options

After entering the installer access code the first option is displayed as shown in the screen below.

**INSTALLER MENU**  
**1-FireDrill, Nxt**

Pressing 1 will select the fire drill function. The fire drill operates the same from the user or installer menu. Pressing the Next key will display the next installer menu option.

**INSTALLER MENU**  
**2-Date/Time, Nxt**

Pressing 2 will select the editing of the date and time. The date and time adjustment is the same for both the user and installer menu. Pressing the Next key will display the next installer menu option.

**INSTALLER MENU**  
**3-Walk Test, Nxt**

Pressing 3 will select the walk test function. The walk test function is the same for both the user and installer menus. Pressing the Next key will display the next installer menu option.

**INSTALLER MENU**  
**4-EventHist, Nxt**

Pressing 4 will select the event history display. From the installer menu the event history can be viewed and cleared. Pressing the Next key will display the next installer menu option.

**INSTALLER MENU**  
**5-DisableEn, Nxt**

Pressing 5 will select the Disable/Enable menu. Only the installer menu allows access to this operation. Pressing the Next key will display the next installer menu option.

**INSTALLER MENU**  
**6-DACT Test, Nxt**

Pressing 6 will select the manual DACT test. Only the installer menu allows access to this operation. Pressing the Next key will display the next installer menu option.

**INSTALLER MENU**  
**7-ProgramNxt**

Pressing 7 selects the programming menu. Only the installer access code allows access to the programming menu. Pressing the Next key will take the display back to option 1, Fire Drill.

## 4.6 Fire Drill

The fire drill function is accessible from both the user and installer menus. Select option 1 from either the user or installer menu.

Once the Drill option is selected you will see the screen below:

```
Fire Drill
Yes
```

Press Enter to start the fire drill. Press No and Enter, or the ESC key to not start the fire drill and return to the previous menu.

Once the fire drill is active, all output circuits mapped to at least one zone and configured for the NAC function will activate with the cadence pattern used for fire alarm. When the fire drill is active the screen below will be displayed.

```
Press Any Key To
Stop Fire Drill
```

Press any of the 15 keys on the keypad to cancel the fire drill. Once cancelled, a system reset is performed to restore the panel to normal standby.

## 4.7 Date/Time Setup

The date and time can be set from option 2 of either the user or installer menus. The first date and time edit screen that is displayed is below. Choose American or European date/time format.

```
DATE/TIME TYPE
1Amer 2Euro
```

Select 1 for North American format. Select 2 for European format.

```
DATE: 00/00/00
TIME: 00:00 am
```

At this screen enter the date and press enter. If the date is already correct you may just hit the enter key to move on to the time setting. Enter the time and use the 2 key for am or the 7 key for pm and press enter.

```
USE DST
Yes/No
```

If day light savings time (DST) adjustment is enabled (Yes), then more screens will appear for selecting the start and end weeks of DST. Press the Yes or No key to enable or disable DST followed by the Enter key.

```
DST START
MONTH nn, WEEK n
```

The daylight savings time is put into effect on a Sunday at 2:00am. Select the month and week of the month, at which time DST will go into effect. Type month (1..12) followed by Enter. Type the week number. Press Enter.

```
DST END
MONTH nn, WEEK n
```

The daylight savings time ends on a Sunday at 2:00am. Select the month and week of the month, at which time DST will end. Type month (1..12) followed by Enter. Type the week number. Press Enter

Note: If you want DST to start or end on the last Sunday of the month whether it is the 4<sup>th</sup> or 5<sup>th</sup> Sunday, use 5 for the week of the month parameter.

## 4.8 Walk Test

The walk test is designed to be used for on-site testing only and is available from option 3 of either the user or installer menus.

Select which circuit to test from the first walk test screen displayed below:

**WALK TEST**  
**SELECT ZONE: n**

A walk test is performed one zone at a time. Select the zone to be tested. The panel will be in trouble as the other zones are disabled until you exit walk test.

During walk test, the display will show the number of detectors that went into alarm. Each alarm will cause the NACs and relays assigned to the zone to activate for 4 seconds and then the zone will be automatically reset.

**WALK TEST ZONE 2**  
**TOTAL ALARMS: 3**

In this example zone 2 is in walk test mode and the zone has been put into alarm 3 times during the walk test.

To exit walk test mode, press “Esc” after the last alarm is reset and the screen above is displayed.

## 4.9 Event History

The event history can be reviewed from both the installer and user menus, option 4. The event history can only be cleared from the installer menu.

### 4.9.1 Viewing Event History

From the user or installer main menu, select option 4 to view the event history. The next screen displayed will be the most recent event in the event history if accessed from the user menu. When accessed from the installer menu, the screen below is displayed:

**Event History**  
**1.Review 2.Clear**

Select 1 to view event history or 2 to erase all history.

When viewing event history from the user or installer menu, the display will show as follows if the history is completely clear:

**No Event History**

This is displayed when the event history is empty.

The above message will last for a few seconds and then you will be returned to the previous menu. When the event history has one or more valid events the most recent event will be displayed first. If you press the down arrow you will see the next most recent event (moving towards older events). If you press the up arrow you will move towards more recent events. Up to 255 events will be stored before the oldest events are overwritten.

When there is at least one event, but less than 255 events, and you reach the end of the valid event history the display will show:

```
MM/DD HH/MM/SS
No Event At 255
```

This is the format displayed at the end of valid history.

When there is at least one event, but less than 255 events, and you go past the newest event the display will show:

```
MM/DD HH/MM/SS
No Event At N
```

This is the format displayed one location past the beginning of valid history where N is the number of valid events in the history.

## 4.9.2 Clearing Event History

It is often useful to clear out the event history after troubleshooting problems or just after system is commissioned. You can only clear the event history from the installer menu. From the installer main menu, select option 4 to reach the screen below.

```
Event History
1.Review 2.Clear
```

Select 2 to erase all event history.

The screen will display:

```
Erasing History
```

This will display for a few seconds while the history is erased. You will then be returned to the installer main menu.

## 4.10 Disabling Circuits

### 4.10.1 Disabling or Enabling Zones

Zones can only be disabled from the installer menu. The zone enable screen provides the ability to disable a zone and then re-enable the zone at a later time. When a zone is disabled it is ignored by the control panel and cannot cause an alarm. A disabled zone will be indicated as a supervisory condition for the zone until you re-enable it.

Enter an installer access code to access the main installer menu. Select option 5 to disable or enable a zone. Enter the zone number you wish to disable or enable at the screen below.

```
ZONE SETUP
SELECT ZONE #:
```

Select the zone numbers 1-2 for the HCA-2, 1-4 for the HCA-4 and 1-8 for the HCA-8 model.

Once you select the zone number, the following screen will display.

```
ZONE 1 ENABLE
YES
```

In this example, the screen shows that zone 1 is currently enabled. To disable it, press the No key. To enable a disabled zone, press the Yes key from this screen.

Press the ESC key several times to back out of the installer menu and return to the idle display. To enable a zone, return to the installer menu and traverse the menus down to the same zone enable screen used to disable the zone. At the enable screen select the Yes key to enable the zone. The supervisory condition associated with the zone being disabled will restore. Press the ESC key several times to back out of the installer menu.

#### 4.10.2 Disabling or Enabling Outputs

Output Circuits cannot be disabled from the installer menu at this time. You must physically disconnect the output wiring from the terminal block to disable an output at this time.

#### 4.11 Manual DACT test

The manual DACT test can only be initiated from the installer menu. Select option 6 from the installer main menu to get to the manual DACT test. The screen below will be displayed.

```
Force DACT test:
(Y/N): N
```

To perform the manual DACT change the N to Y by pressing the Yes (9) key and then press the Enter key.

The screen below will display briefly before returning to the main installer menu.

```
Manual DACT test
Started
```

This screen displays briefly after initiating the manual DACT test.

If the DACT is enabled, the manual DACT test will force the DACT to report a manual test code to all accounts that have the test report filter active. (See programming section for details). Repeated initiation of the manual DACT test will alternate phone lines so that performing the manual DACT twice will insure that both phone lines are tested also.

#### 4.12 Operating the Remote Annunciator

When a remote annunciator is installed, the end users can view system status and perform silence and reset functions remotely from the HCA panel. The remote annunciator keypad is enabled by inserting and rotating the mechanical key to the active position. Once the key is in the active position users can silence and reset the HCA panel from the remote annunciator. Note that the remote annunciator must be enabled in order for the silence and reset functions to work. See section 5.5 for instructions on adding a remote annunciator through programming.

## 5. Programming

The programming menu is accessible only from the installer menu. Enter the installer access code and select option 7 from the top level installer menu to enter the programming menu.

### 5.1 Editing User and Installer Access Codes

The HCA panel supports a user and installer access code. The user code is allowed to perform a fire drill, set the date and time, perform a walk test and review the event history. The installer code has access to all of the user code functions plus disabling circuits, executing a manual DACT test and editing all of the programming options.

This first screen displayed when you enter the programming menu is below.

```
PROGRAMMING MENU
1-UserCodes, Nxt
```

Pressing 1 will take you to the screen to edit the user and installer access codes. Pressing the Next key will display the next programming menu option.

After selecting 1 for User Codes you will see:

```
SELECT TYPE USER
1-USER. 2-ADMIN
```

Select 1 to edit the user code. Select 2 to edit the installer code.

If you select 1, you will see:

```
USER PASSWORD
ENTER CODE:
```

Type in the 4 digit code you want for the user code and press Enter

If you select 2, you will see:

```
ADMIN PASSWORD
ENTER CODE:
```

Type in the 4 digit code you want for the installer code and press Enter

### 5.2 Zone Programming Options

Select option 2 from the main programming menu to edit the zone options.

```
PROGRAMMING MENU
2-EditZones, Nxt
```

Pressing 2 will select the editing of the zone options. Pressing the Next key will display the next programming menu option.

#### 5.2.1 Zone Edit

After selecting option 2 for editing zones, the screen below will display.

```
ZONE SETUP MENU
1-Edit Zone, Nxt
```

Select 1 to edit specific zone programming options. Or, press Next to display the shorted zone mode option.

After selecting option 1 for editing a specific zone, the screen below will display.

**ZONE SETUP**  
**SELECT ZONE #:**

Select the zone numbers 1-2 for the HCA-2, 1-4 for the HCA-4 and 1-8 for the HCA-8 model.

### 5.2.1.1 Zone Type

Each of the zones can be configured as FIRE, ALARM VERIFICATION or SUPERVISORY type. FIRE type zones initiate a fire alarm after the zone response debounce if the circuit is activated. ALARM VERIFICATION type zones will initiate a fire alarm only after the zone is initially activated and then reset by the panel and then verified to still be in alarm during the alarm verification period. A SUPERVISORY type zone will indicate a supervisory alarm when it is activated. Use the down arrow to rotate through the alarm types and press the enter key to make the zone type selection.

**ZONE 1 TYPE**  
**FIRE**

In this example, the screen shows that zone 1 type is currently FIRE. To change the zone type use the down arrow key until the desired zone type is present and select enter.

### 5.2.1.2 Zone Response

Each zone has an alarm debounce delay time that can be used to reduce false alarms. The possible range for the alarm debounce is 1-60 seconds. The default value is 1 second.

**ZONE 1 RESPONSE**  
**SECONDS: 1**

In this example, the screen shows that the zone 1 response time is 1 second. To change the response time enter the desired time followed by the enter key.

### 5.2.1.3 Zone NAC Activation

Each zone has a list of NACs which will be active when the zone is in alarm. The default value is for all 4 NACs to activate for all of the zones. Note that this screen is skipped when the zone is configured as a supervisory zone. Supervisory zones can only activate relays and not NAC output circuits.

**ZONE 1 NACs**  
**1-34**

In this example, the screen shows that the zone 1 will activate NACs 1, 3 and 4. The dash indicates that NAC 2 will not activate. Select the keys 1 through 4 to toggle the activation programming for each NAC.

### 5.2.1.4 Zone Relay Activation

Each zone has a list of programmable relays which will be active when the zone is in alarm. The default value is for all 3 programmable relays to not be active when the zone is in alarm.

**ZONE 1 RELAYS**  
**12-**

In this example, the screen shows that the zone 1 will activate relays 1 and 2, but not relay 3. A dash indicates that the relay will not activate. Select keys 1 through 3 to toggle the activation for each programmable relay.

## 5.2.2 Shorted Zone Mode

The HCA panel provides a programming option which determines the behavior of shorted zones. Most smoke detectors do not apply a zero ohm dead short impedance across the zone when they provide an alarm condition. Manual pulls stations on the other hand are typically constructed to provide a zero ohm impedance or an impedance that is similar in value to what a smoke detector would apply across a zone when in an active state. If you are using manual pull stations that apply a zero ohm dead short impedance when activated you want to select Yes to the "Shorted Z=Alarm?" question for this programming option. If you are using manual pull stations that apply an impedance above 220 ohms across the zone when activated you may want to select No to the "Shorted Z=Alarm?" programming

question. If you select no, zones that are completely shorted will be interpreted as being in trouble and not alarm. This programming option defaults to interpreting shorted zones as alarm (Yes).

**ZONE SETUP MENU**  
**2-Short Mode Nxt**

Select 2 to edit the shorted zone mode option. Press Next to go back to the zone edit option.

The screen below will display when 2 is selected.

**Shorted Zn=Alarm**  
**Yes**

Select Yes to interpret shorted zones as an alarm. Select No to interpret shorted zones as a trouble.

### 5.3 Output Circuits and Relay Programming

Each output circuit can be individually programmed as either a notification appliance circuit (NAC), auxiliary power resettable circuit, auxiliary power continuous circuit or auxiliary power door holder circuit.

Select option 3 from the main programming menu to edit output circuits and programmable relay options.

**PROGRAMMING MENU**  
**3-Outputs, Nxt**

Pressing 3 will select the output programming menu. Pressing the Next key will display the next programming menu option.

The first screen for editing the outputs and relays is below.

**OUTPUT SETUP**  
**1NAC 2RELAY Next**

Select 1 from the output menu for output circuit (NAC) programming

#### 5.3.1 Reserved

#### 5.3.2 NAC Output circuits

##### 5.3.2.1 Strobe Synchronization Silencing Option

When an output circuit cadence pattern is configured as Gentex built-in synchronization, the panel behavior during system silence can be configured to leave the strobes on while silencing the horns or the panel can silence both the horns and strobes.

The first programming screen for the output circuits sets up the strobe silencing characteristics for circuits programmed with the Gentex cadence pattern.

**Strobes left on**  
**for silence: No**

When this programming option is Yes, Gentex strobes will be left active if the NAC is configured as silenceable. When No, both horns and strobes will be silenced.

### 5.3.2.2 NAC Silencing Attributes

The next programming screen for the NAC outputs sets up the silencing characteristics for circuits programmed as FIRE NAC. Each output configured as a NAC circuit from the zone mapping can be configured as silenceable or not silenceable when the silence key is pressed. In the screen below press the number keys 1, 2, 3 or 4 to toggle the silenceable characteristics for circuits 1, 2, 3 and 4. Press Enter to accept the selections when complete. The silenceable option has no effect on circuits not programmed as FIRE NAC from the zone programming menus.

**SILENCEABLE NACs**  
-- 3 --

In this example, the screen shows that only NAC circuit 3 is silenceable. Circuits 1, 2 and 4 are not silenceable.

### 5.3.2.3 Assigning Outputs to the Resettable Auxiliary Power Function

Output circuits that will be used as resettable 24VDC power need to be selected in the AUX RESETTABLE programming screen. In the programming screen below press the number keys 1, 2, 3 or 4 to toggle whether circuits 1, 2, 3 or 4 are used for resettable auxiliary power or not. Press Enter to accept the selections when complete. Circuits programmed as resettable power will have continuous 24V power present except for 10 seconds when the reset key is pressed.

**AUX RESETTABLE**  
- 2 --

In this example, the screen shows that only output circuit 2 has been assigned a resettable power function. Circuits 1, 3 and 4 are used for other functions.

### 5.3.2.4 Assigning Outputs to the Continuous Auxiliary Power Function

Output circuits that will be used as constant 24VDC power need to be selected in the AUX CONTINUOUS programming screen. In the programming screen below press the number keys 1, 2, 3 or 4 to toggle whether circuits 1, 2, 3 or 4 are used for continuous auxiliary power or not. Press Enter to accept the selections when complete. Circuits programmed as continuous power will always have power present even when running on battery backup unless the circuit has an over current fault trouble.

**AUX CONTINUOUS**  
-- 3 --

In this example, the screen shows that only output circuit 3 has been assigned a continuous power function. Circuits 1, 2 and 4 are used for other functions.

### 5.3.2.5 Assigning Outputs to the Door Holder Auxiliary Power Function

Output circuits that will be used as door holder 24VDC power need to be selected in the AUX DOOR MAGNETS programming screen. In the programming screen below press the number keys 1, 2, 3 or 4 to toggle whether circuits 1, 2, 3 or 4 are used for door holder power or not. Press Enter to accept the selections when complete. Circuits programmed as door holder power will have continuous 24V power present unless the AC power is gone and the panel is running on battery standby. If the AC power fails the door holder power is shut down to conserve the battery backup and the door holder current load is not included in the battery backup calculations.

**AUX DOOR MAGNETS**  
--- 4

In this example, the screen shows that only output circuit 4 has been assigned a door holder power function. Circuits 1, 2 and 3 are used for other functions.

**Note for all Auxiliary Power functions:** Be sure that the Cadence Pattern setting is Continuous. See section 5.3.4 for details on this setting.

### 5.3.3 Relay Silencing Programming

From the output programming menu select option 2, RELAY. Each of the 3 programmable relays can be configured as silenceable or not silenceable. Use the numbers 1, 2 and 3 to select relays 1, 2 or 3 as silenceable. A dash indicates the relay is non-silenceable.

**SILENCEABLE RLYS**  
-- 3

In this example, the screen shows that only relay 3 is silenceable. Relays 1 and 2 are non-silenceable.

NOTE: If you want to select which relays activate when an alarm or supervisory event occurs, go to the zone programming menus to map the relays to the individual zones.

### 5.3.4 Cadence Pattern Programming

Each output that is programmed as a NAC will operate with a cadence pattern when activated. (Continuously on is one of the valid cadence patterns). The cadence pattern is programmed individually for each circuit.

**OUTPUT SETUP**  
**3.Cadence**

Select 3 from the output menu for cadence programming

**NAC 1 CADENCE**  
**Continuous**

The first screen is NAC 1 cadence. Use the down or up arrows to change the cadence, then press the enter key to move on to the next NAC.

The cadence pattern choices are:

- 1) Continuous – The output will be on continuously.
- 2) Gentex Sync – Select this option if using Gentex appliances and you want the strobes in sync.
- 3) March Code – This option will produce a pattern of 5 seconds on, 5 seconds off
- 4) Temporal Code – This option will produce the ANSI 3.41 temporal coded pattern of 0.5 seconds on, 0.5 seconds off, 0.5 seconds on, 0.5 seconds off, 0.5 seconds on, 1.5 seconds off, repeat.

**Note:** Be sure that the Cadence Pattern is set as *Continuous* for all NACs being used with Auxiliary Power functions such as Door Holder and Resettable Auxiliary Power.

## 5.4 Releasing Programming Options

The HCA panel provides both water and agent releasing programming options. You must use either the HCA-4 or HCA-8 if you are using releasing features as all releasing programming options require the use of zones 1 through 4. Note that if you want to use a disconnect switch for the releasing circuit, you must use the HCA-8! Both the water and agent releasing configurations use zones 2 and 3 for cross alarm functions and zone 4 as a manual release alarm function; zone 5 of the HCA-8 is used for the disconnect circuit (see section 5.4.3). The zone 1 function depends on the releasing option chosen as detailed in the following sections.

Select option 4 from the main programming menu to reach the programming options for releasing.

### 5.4.1 Agent Releasing

The agent releasing option configures the panel for the cross zone releasing configuration shown in figure 5.1. Figure 5.2 is a truth table that shows the cross alarm or manual release inputs that are needed for agent releasing to occur.

**PROGRAMMING MENU**  
**4-Releasing, Nxt**

Pressing 4 will select the releasing programming options. Pressing the Next key will display the next programming menu option.

Set the release mode in the first screen.

**Releasing Option**  
**Agent Release**

Use the down arrow to scroll through None, Water Release and the Agent Release options. Once the desired release option is shown press the enter key to accept the option.

Select the pre-alarm delay time before the solenoid activates once cross zones 2 and 3 are both active.

**Solenoid Cross**  
**Alarm Delay: 30**

Select solenoid delay time. Default is 30 seconds. Possible range is 30-60 seconds.

Select whether the Solenoid output should be automatically shut down after the shutdown timer expires.

**Auto Shutdown**  
**Solenoid(Y/N): Y**

Choose the auto shutdown solenoid option. Select Y for the auto shutdown solenoid feature. Select N to leave the solenoid active until system reset. Press enter to accept displayed option on the screen. Default is Y (Yes).

If you select Y for Auto Shutdown Solenoid, the screen below will display to select the auto shutdown time.

**Solenoid Shutdwn**  
**Time: 030**

Select solenoid delay time. Default is 30 seconds. Possible range is 10-600 seconds.

Finally, select the output cadence pattern for NACs 2, 3 and 4. NAC 1 cadence is always continuous.

**Release Pattern**  
**Continuous**

Use down arrow to scroll through cadence patterns for output circuits 2, 3 and 4 with the releasing function. Once the desired cadence is shown press enter key to accept cadence option.

The releasing cadence patterns are:

- 1) Continuous – The output will be on continuously.
- 2) Gentex Sync – Select this option if using Gentex appliances and you want the strobes in sync.
- 3) March Code – This option will produce a pattern of 5 seconds on, 5 seconds off
- 4) Temporal Code – This option will produce the ANSI 3.41 temporal coded pattern of 0.5 seconds on, 0.5 seconds off, 0.5 seconds on, 0.5 seconds off, 0.5 seconds on, 1.5 seconds off, repeat.

#### **5.4.1.1 Zone and Output Definitions for Agent Releasing Option**

When you configure the HCA panel for the agent releasing option, the zones and outputs are configured as follows:

- Zone 1 is configured as an abort zone. The abort function is non-latching. It must remain active as long as it is desired to abort the releasing function. If the abort switch is deactivated before the panel is reset, the remaining pre-alarm delay time will continue to count down to zero at which time releasing will occur.
- Zones 2 and 3 are configured for cross zone releasing. Zones 2 and 3 are intended to be populated with automatic initiating devices such as smoke detectors. When the first zone of zones 2 and 3 becomes active, output circuit 4 will activate indicating general alarm. When both zones 2 and 3 become active, a pre-alarm delay period (default 30 seconds) occurs where zone 1 can abort the releasing function. Output circuit 2 will activate at the beginning of the pre-alarm delay period to alert personnel of the pending agent release. If abort zone 1 is not activated by onsite personnel within the pre-alarm period, output circuit 1 will activate and discharge for either the programmed shutdown time or until system reset depending on the programming configuration. Output circuit 3 activates when output 1 activates and remains active until system reset indicating that the discharge has occurred. The cross zoning of zones 2 and 3 requires that at least one detector from each zone must be in alarm in order to activate the agent releasing output circuit 1 and the releasing indicator, output circuit 3.
- Zone 4 is a manual release zone. Manual releasing switches must be wired to zone 4 so that when one or more release switches are activated, agent releasing occurs immediately. As soon as zone 4 activates, output circuit 4 activates indicating general alarm. There is no pre-alarm delay period for manual release, so output circuit 2 activates immediately along with circuits 1 and 3 which will release the agent and indicate that a release has occurred. An active manual release will override any pre-alarm delay that might be occurring with the cross alarms and activate the agent release immediately.
- Zone 5 of the HCA-8 is automatically configured as a normally-closed supervisory zone. This zone is used with the releasing circuit disconnect switch. When the switch is activated it does two things; it physically disconnects the releasing circuit, and it creates a supervisory condition on zone 5. See section 5.4.3 of this manual for additional information and wiring instructions.
- Zones 6 through 8 on the HCA-8 behave as non-releasing fire, alarm verification or supervisory zones based on the programming options for these zones.
- Output Circuit 1 is dedicated for the agent release function. It will activate (discharge) after the pre-alarm delay has expired for cross zones 2 and 3, or immediately after the manual release zone 4 is activated. To prevent the pre-alarm period from expiring and preventing the output circuit from agent release, the abort zone 1 must become active within the pre-alarm delay period. Output circuit 1 will automatically shut down once activated after the auto shutdown timer has expired or it will remain active until system reset depending on the panel programming.
- Output Circuit 2 activates during the pre-alarm period to indicate the pending release and stays active after the agent releasing circuit 1 activates and until the panel is reset.
- Output Circuit 3 activates at the same time as the agent release circuit 1 to indicate a release has occurred and stays active until the panel is reset.
- Output Circuit 4 activates when at least one of zone 2, 3 or 4 activate to indicate general alarm. Output Circuit 4 may also operate in response to zones 6 – 8 of the HCA-8, depending on their programming.

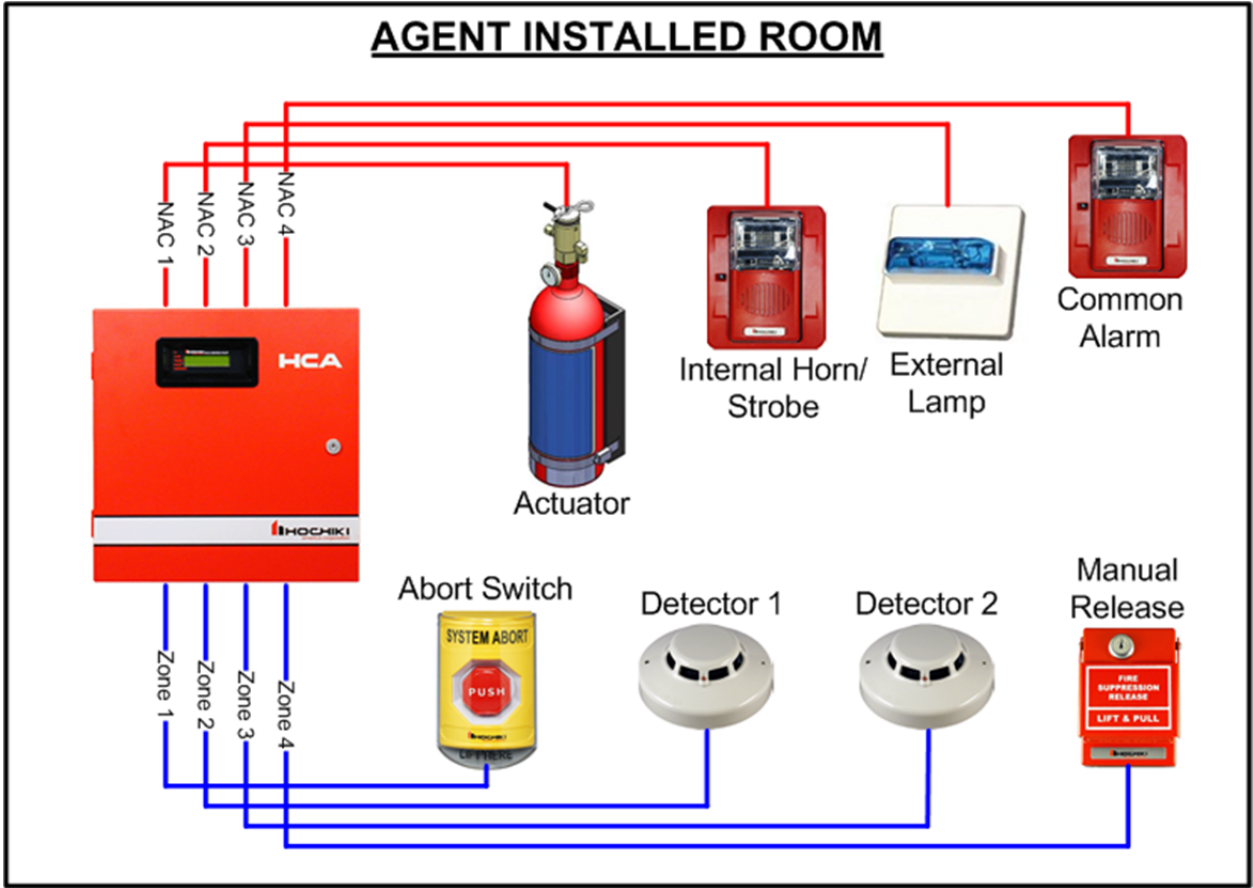

Figure 5.1 – Agent Releasing Configuration

#### Agent Releasing Truth Table

	Manual Release	Cross Zone B	Cross Zone A	Inputs
Normal Standby				Outputs
Common Alarm			☑	
Common Alarm		☑		
Common Alarm and Release		☑	☑	
Common Alarm and Release	☑			
Common Alarm and Release	☑		☑	
Common Alarm and Release	☑	☑		
Common Alarm and Release	☑	☑	☑	

Figure 5.2 – Agent Releasing Truth Table

## 5.4.2 Water Releasing

There is both a single interlock and double interlock water releasing programming option. The single interlock release has similar behavior to the agent release programming option. The difference between single interlock and agent releasing is that zone 1 is configured as a supervisory zone for single interlock vs. an abort function for agent releasing. Note also that there is no pre-alarm delay for a cross alarm of zones 2 and 3 with water releasing as there is for agent releasing.

The double interlock zone uses zone 1 as the interlock switch alarm zone. The interlock switch is required to be active along with a cross alarm of zones 2 and 3, or the manual release zone 4 in order for there to be a release.

See figure 5.3 for the water releasing truth table indicating what zones must be active in order for there to be a water release.

To set up the panel for the water releasing select option 4 from the main menu.

**PROGRAMMING MENU**  
**4-Releasing, Nxt**

Select 4 from the main menu for general releasing.

Select the Water Release mode.

**Releasing Option**  
**Water Release**

Use the down arrow to scroll through None, Water Release and Agent Release options. Once the desired release option is shown press the enter key to accept the option.

Select either single or double pre-action mode for the water release option.

**Pre-Action Mode**  
**Single Interlock**

Use the down arrow to scroll through Single Interlock and Double Interlock. Once the desired interlock mode is shown press enter key to accept the option.

Select whether the Solenoid output should be automatically shut down after the shutdown timer expires.

**Auto Shutdown**  
**Solenoid(Y/N): Y**

Choose the auto shutdown solenoid option. Select Y for auto shutdown solenoid feature. Select N to leave solenoid active until system reset. Press enter to accept option displayed on the screen. Default is Y (Yes).

If you select Y for Auto Shutdown Solenoid, the screen below will display to select the auto shutdown time.

**Solenoid Shutdwn**  
**Time: 030**

Select solenoid delay time. Default is 30 seconds. Possible range is 10-600 seconds.

Finally, select the output cadence pattern for NACs 2, 3 and 4. NAC 1 is always the continuous pattern.

**Release Pattern**  
**Continuous**

Use down arrow to scroll through cadence patterns for output circuits 2, 3 and 4 with the releasing function. Once desired cadence is shown press the enter key to accept cadence option.

The releasing cadence patterns are:

- 1) Continuous – The output will be on continuously.
- 2) Gentex Sync – Select this option if using Gentex appliances and you want the strobes in sync.
- 3) March Code – This option will produce a pattern of 5 seconds on, 5 seconds off
- 4) Temporal Code – This option will produce the ANSI 3.41 temporal coded pattern of 0.5 seconds on, 0.5 seconds off, 0.5 seconds on, 0.5 seconds off, 0.5 seconds on, 1.5 seconds off, repeat.

#### 5.4.2.1 Zone and Output Definitions for Water Releasing Options

When you configure the HCA panel for single or double interlock water releasing, the zones and outputs are configured as follows:

- Zone 1 is configured as a supervisory zone for the **single** interlock option. You would normally use this to monitor sprinkler piping pressure in single interlock applications.
- Zone 1 is configured as an interlock switch alarm zone for the **double** interlock option. In order for a release to occur both the double interlock zone (zone 1) and either the manual release zone or both cross alarm zones must be active.
- Zones 2 and 3 are configured for cross zone releasing. Zones 2 and 3 are intended to be populated with automatic initiating devices such as smoke detectors. When the first zone of zones 2 and 3 becomes active, output circuit 4 will activate indicating general alarm. The cross zoning of zones 2 and 3 requires that at least one detector from each zone must be in alarm in order for the cross zone alarm to be active which will cause a water release for single interlock and may occur for double interlock depending on the state of the interlock zone 1.
- Zone 4 is a manual release zone. Manual releasing switches must be wired to zone 4 so that when one or more release switches are activated, a water release for single interlock will occur and may occur for double interlock depending on the state of the interlock zone 1.
- Zone 5 of the HCA-8 is automatically configured as a normally-closed supervisory zone. This zone is used with the releasing circuit disconnect switch. When the switch is activated it does two things; it physically disconnects the releasing circuit, and it creates a supervisory condition on zone 5. See section 5.4.3 of this manual for additional information and wiring instructions.
- Zones 6 through 8 on the HCA-8 behave as non-releasing fire, alarm verification or supervisory zones based on the programming options for these zones.
- Output Circuit 1 is dedicated for the water release solenoid(s). It will activate when the release requirements for single or double interlock have all been met. Output circuit 1 will automatically shut down once activated after the auto shutdown timer has expired or it will remain active until system reset depending on the panel programming.
- Output Circuit 2 activates at the same time as output 1 for water releasing because there is no cross alarm delay for water releasing. Output 2 stays active until the panel is reset.
- Output Circuit 3 activates at the same time as output 1 to indicate a release has occurred and stays active until the panel is reset.
- Output Circuit 4 activates when at least one of zone 2, 3 or 4 activate (or zone 1 for double interlock) to indicate general alarm. Output Circuit 4 may also operate in response to zones 6 – 8, depending on their programming.

Single Interlock Truth Table					Double Interlock Truth Table							
	Inputs	Cross Zone A	Cross Zone B	Manual Release	Outputs		Inputs	Interlock	Cross Zone A	Cross Zone B	Manual Release	Outputs
Normal Standby						Normal Standby						
Common Alarm						Common Alarm						
Common Alarm						Common Alarm						
Common Alarm and Release						Common Alarm						
Common Alarm and Release						Common Alarm						
Common Alarm and Release						Common Alarm						
Common Alarm and Release						Common Alarm						
Common Alarm and Release						Common Alarm						
						Common Alarm						
						Common Alarm						
						Common Alarm						
						Common Alarm and Release						
						Common Alarm and Release						
						Common Alarm and Release						
						Common Alarm and Release						
						Common Alarm and Release						

Figure 5.3 – Water Releasing Truth Table

### 5.4.3 How to Install the Disconnect Switch on the Releasing Circuit

NFPA requirements state that a releasing service fire alarm system shall be provided with a disconnect switch to allow the system to be tested without actuating the fire suppression systems. This disconnect switch shall be a physical switch. When the switch is operated the panel shall indicate a supervisory signal at the control unit (NFPA 72 2010 Edition, 23.13.5). This section explains how to connect the disconnect switch to the HCA.

**You will need a Hochiki America SOM-R-DS Disconnect Switch for this application.**

The disconnect switch is connected in-line with the releasing circuit (NAC 1). When the switch is operated, it creates an open-circuit condition which prevents the release of the extinguishing agent. The switch is also connected to Zone 5 on the panel. When the switch is operated to disable NAC 1, zone 5 will be activated to indicate a supervisory signal at the panel.

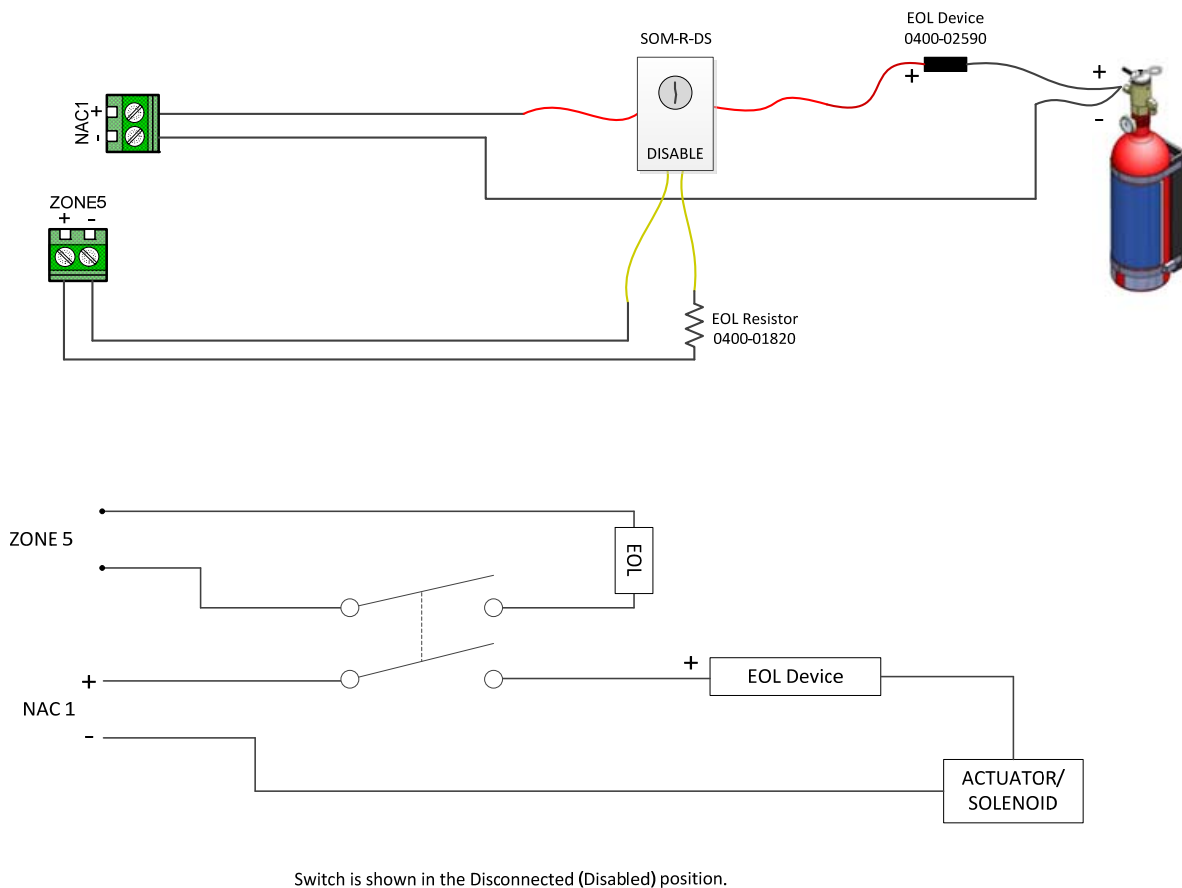

**Figure 5.4 – Disconnect Switch for Releasing**

Additional notes about Releasing:

- The only programmable options for zones 1 – 5 are the relay settings when releasing is selected.
- The 4-zone HCA panel does not have the capability of supporting a disconnect switch because the panel only has four zones; there is no zone 5. The 4-zone HCA may be used for applications where a disconnect switch is not required. ***ALWAYS confirm with your AHJ before installing the system!***

When the disconnect switch is operated it will result in two messages on the HCA control panel:

1. A Supervisory event on zone 5
2. A “NAC CIRCUIT 1 Trouble” event

When these events are present on the panel ensure that the disconnect switch is in the intended position. *The disconnect switch should always be in the ENABLED position except when service or maintenance is being performed.*

## 5.5 Remote Annunciator

The programming option to indicate the presence of a remote annunciator is located in option 5 of the programming menu. The HCA panel supports up to 1 remote annunciator.

**PROGRAMMING MENU**  
**5-RemoteDis, Nxt**

Pressing 5 will select the remote annunciator menu. Pressing the Next key will display the next programming menu option.

The screen below displays after selecting option 5.

**Annunciator En 1**  
**No**

Select Yes if you are going to use the remote annunciator or select no if no remote annunciator will be used.

## 5.6 DACT Setup

Models HCA-2D, HCA-4D and HCA-8D have a built in Digital Alarm Communicator Transmitter (DACT) for reporting events via telephone lines to a compatible remote central station receiver. Select Option 6 from the programming menu to edit the DACT programming options.

**PROGRAMMING MENU**  
**6-Edit DACT, Nxt**

Pressing 6 will select the DACT programming options. Pressing the Next key will display the next programming menu option.

### 5.6.1 Enable/Disable the DACT

There is a master enable flag for the DACT which allows the installer to enable or disable the DACT easily without changing any other DACT programming options. Note that the panel will not be in trouble if you turn off the DACT using this master enable flag. It is an acceptable programming configuration to use one of the HCA panels that includes the DACT hardware, but not actually enable the DACT. The default setting for this enable flag is No. You will need to enable the DACT and properly program account numbers and phone numbers before it will be able to report events. Models without the DACT hardware will not display the enable/disable DACT option.

**Enable DACT**  
**(Y/N): N**

Press Y and Enter to enable the DACT. Press N and Enter to turn off the DACT.

### 5.6.2 Auto Test Time of Day

The auto test is a daily test (every 6 or 24 hours) that will report a test code to the remote central station receiver to indicate that the panel is capable of remote communications. The auto test will alternate the phone line used to ensure that each phone line is in good working order.

The first DACT programming screen is the hour of the day the auto test will occur.

**Auto Test Time**  
**Hour (0-23):02**

Enter the hour when the auto test will occur followed by Enter. Default time is 2:00AM.

The next DACT programming screen is the minute within the hour of the day for the auto test.

**Auto Test Time  
Minute(0-59): 00**

Enter the minute the auto test will occur followed by Enter. Default time is 2:00AM.

The next DACT programming screen sets the interval for the auto test.

**AutoTest Period:  
Run Every 6 hrs**

The auto test interval may be set to 24 hours or 6 hours. Use the down arrow key to toggle between the two selections.

### 5.6.3 Low AC Reporting Delay

The Low AC reporting delay is the delay between when a low AC input power condition is detected by the panel and when it gets reported to the central station via the DACT. To be in compliance with UL 864, it is required that this delay be set between 1 hour (60 minutes) and 3 hours (180 minutes). The HCA panel allows for this parameter to be set between 1 minute and 990 minutes for installations that will allow this time to be set outside of the 60 to 180 minute UL864 requirement.

**Low AC Reporting  
Delay (min): 180**

Enter the number of minutes for the low AC reporting delay followed by the Enter key. Default value is 180 minutes.

### 5.6.4 Edit Accounts

There are 4 reporting accounts within the DACT which can be used for reporting the various reportable events to different receivers and/or phone numbers. See table 6.1 for a list of all events that can be reported to the central station and which reporting filter is associated with each possible event.

To edit any of the accounts, select Y (yes) and then enter. To skip past the edit accounts menus select N (no) and the Enter key.

**Edit Accounts  
(Y/N): Y**

Select Y and Enter to edit the account options.

Next, select which of the 4 accounts you wish to edit (possible values 1-4).

**Select Which  
Account(1-4):**

Enter the account index you want to edit.

#### 5.6.4.1 Account Number

Each account has a 6 digit string called the account number that is sent to the central station to identify which account is sending the event(s). The DACT allows up to 6 digits to be used for the account number. If less than 4 digits are used, leading zeros are padded in front of the number to make the account number have a minimum of 4 digits. Contact ID uses only 4 digits. The 4 least significant digits of the account number are used for Contact ID; the upper 2 digits are not used with contact ID, even when more than 4 digits are entered for the account number. Account numbers for SIA can be 4-6 digits in length.

You may enter blanks or spaces in the account number by pressing the Silence key for the 2 most significant digits. The ESC key will back the cursor left one position until you reach the left most digit and then it will escape out of the account edit menu.

**Account Number:**  
123456

Enter the account number you want to use for reporting.

#### 5.6.4.2 Reporting Format

The DACT supports both Contact ID and SIA reporting formats. Use the up or down arrows to scroll through the reporting format selection and press the Enter key when the format you want is visible in the display screen.

**Reporting Format**  
CID

Select the reporting format desired for this account.

#### 5.6.4.3 Alarm Reporting Filter

The alarm reporting filter determines if this account will report alarms and alarm restores to the central station.

**Report Alarms**  
(Y/N): Y

Select Y if you want alarms reported to this account. Select N if you do not want alarms reported.

#### 5.6.4.4 Supervisory Reporting Filter

The supervisory reporting filter determines if this account will report supervisories and supervisory restores to the central station.

**Report Suprvisry**  
(Y/N): Y

Select Y if you want supervisories reported to this account. Select N if you do not want supervisories reported.

#### 5.6.4.5 Trouble Reporting Filter

The trouble reporting filter determines if this account will report trouble and trouble restore events to the central station.

**Report Trouble**  
(Y/N): Y

Select Y if you want troubles reported to this account. Select N if you do not want troubles reported.

#### 5.6.4.6 Tests Reporting Filter

The tests reporting filter determines if this account will report tests and test restore events to the central station.

**Report Tests**  
(Y/N): Y

Select Y if you want test events reported to this account. Select N if you do not want test events reported.

#### 5.6.4.7 Fire Drill Reporting Filter

The fire drill reporting filter determines if this account will report fire drill begin and fire drill end events to the central station.

**Report FireDrill  
(Y/N): Y**

Select Y if you want fire drill events reported to this account. Select N if you do not want test events reported.

#### 5.6.4.8 Disable/Enable Circuits Reporting Filter

The disable reporting filter determines if this account will report circuit disable and enable events to the central station.

**Report Disables  
(Y/N): Y**

Select Y if you want disable and enable circuit events reported to this account. Select N if you do not want disable and enable events reported.

#### 5.6.4.9 Primary Phone Number

Each account has a 20 digit primary phone number for calling the central station. The primary phone number is always used first; the secondary phone number is only used when the DACT is unable to communicate using the primary phone number.

In addition to the digits "0" through "9", you can also insert commas "," that will generate pauses between the digits being dialed. This might be useful when you need to dial an outside line when connected to a local PBX. To enter a comma, the "ACK" key is used when entering the phone number. Commas count as part of the 20 digit limitation in the phone number. You can also enter spaces by using the SILENCE key. The ESC key will back the cursor left one position until you reach the left most digit and then it will escape out of the phone number edit menu.

**PrimaryPhoneNum:**

Enter the first phone number to call when this account needs to report an event.

#### 5.6.4.10 Secondary Phone Number

Each account has a secondary phone number for calling the central station when the account is unable to get through on the primary number. If you only want to have the account attempt to call one number you can program the primary number in both the secondary and primary programming locations.

**SecondPhoneNum:**

Enter the secondary number to call when this account cannot report events using the primary phone number

### 5.6.5 Edit Phone Lines

The DACT has 2 phone lines for reporting to a central station receiver. Both lines must be used for proper operation of the DACT. In addition, both phone lines must be supervised for the panel installation to be compliant with UL864 – see section 5.6.5.2.

**Edit Phone Lines**  
**(Y/N): N**

If you want to edit the programming options specific to the phones lines, enter Y and the Enter key to see the first programming screen on the phone lines.

Select which phone line you want to edit.

**Select Phone**  
**Line: (1-2):**

Enter 1 or 2 followed by the Enter key.

#### 5.6.5.1 Dialing Format

Select which dialing format you would like this line to use. You can chose to only use touch tone dialing, a combination of touch tone and pulse dialing when multiple call attempts are needed, or pulse dialing only for dialing the phone number.

**Dialing Format:**  
**Dial Tones Only**

Use the up or down arrow keys to select tone dialing only, tone and pulse dialing, or pulse dialing only.

#### 5.6.5.2 Supervise Phone Line

You can select whether the line is to be supervised for phone line voltage or not by selecting Y (yes) or N (no). Normally, you always want to supervise the phone line and it is a requirement for UL864 and NFPA compliant installations. Default is Y.

**Supervise Line**  
**(Y/N): Y**

Enter Y or N to indicate if the line is to be used or not.

## 5.7 Panel Factory Default Setup

If there is ever a need to start over with the programming process the panel can be brought back to the default factory programming settings. From the programming menu select option 7

**PROGRAMMING MENU**  
**7-Defaults, Nxt**

Pressing 7 will select the programming options to restore the factory default options. Pressing the Next key will take the display back to the option 1 programming menu screen.

The screen below will be displayed after select option 7.

**LOAD DEFAULTS**  
**No**

Select Yes and Enter to reload the manufacturer default settings. Select No and Enter, or Esc to skip defaulting the panel.

### 5.7.1 Factory Default Settings

Default factory settings:

- 1) All zones are configured as FIRE alarm type zones with 1 second response time.
- 2) All zones are mapped to all 4 NAC outputs with continuous cadence pattern for alarm.
- 3) Dead shorts on zone inputs are interpreted as alarm, not trouble. (shorted mode = alarm)
- 4) The releasing features are deactivated.
- 5) The DACT is deactivated.
- 6) The installer access code is defaulted to 3333.
- 7) The user access code is defaulted to 2222.

## 6. DACT Reporting Codes and Compatible Receivers

This section lists all central station receiver output codes that are used for all reportable events in the HCA panel. The HCA control panel is compatible with central station receivers that support SIA and/or Contact ID reporting formats such as those manufactured by ADEMCO, Silent Knight and Sur-Gard.

### 6.1 DACT Reporting Codes for SIA and Contact ID

The table below lists all reportable events in the HCA series control panel and the associated SIA and Contact ID reporting codes.

**Table 6.1 Panel Output Codes for SIA and Contact ID Reporting Formats.**

HCA Panel Event	HCA Reporting Filter Associated with This Event	SIA Reporting Format		Contact ID Reporting Format		
		Event Code	Parameter	Qualifier	Event Code	Contact #
Fire Zone Alarm	Alarm	FA	Zone #	1	110	Zone #
Fire Zone Alarm Restore	Alarm	FH	Zone #	3	110	Zone #
Fire Zone Trouble	Trouble	FT	Zone #	1	373	Zone #
Fire Zone Trouble Restore	Trouble	FJ	Zone #	3	373	Zone #
Fire Zone Disabled	Disablement	FB	Zone #	1	571	Zone #
Fire Zone Enabled	Disablement	FU	Zone #	3	571	Zone #
Supervisory Zone Active	Supervisory	SS	Zone #	1	200	Zone #
Supervisory Zone Restore	Supervisory	SR	Zone #	3	200	Zone #
Supervisory Zone Trouble	Trouble	ST	Zone #	1	373	Zone #
Supervisory Zone Trouble Restore	Trouble	SJ	Zone #	3	373	Zone #
Supervisory Zone Disabled	Disablement	SB	Zone #	1	571	Zone #
Supervisory Zone Enabled	Disablement	SU	Zone #	3	571	Zone #
Notification Circuit Trouble	Trouble	FT	NAC # + 10	1	373	NAC # + 10
Notification Circuit Trouble Restore	Trouble	FJ	NAC # + 10	3	373	NAC # + 10
Fire Drill Begin	Fire Drill	FI	0	1	604	0
Fire Drill End	Fire Drill	FK	0	3	604	0
AC Power Trouble	Trouble	AT	0	1	301	0
AC Power Trouble Restore	Trouble	AR	0	3	301	0
Battery Charger Trouble	Trouble	YP	0	1	312	0
Battery Charger Trouble Restore	Trouble	YQ	0	3	312	0
Low Battery Trouble	Trouble	YT	0	1	302	0
Low Battery Trouble Restore	Trouble	YR	0	3	302	0
Battery Missing Trouble	Trouble	YM	0	1	311	0
Battery Missing Trouble Restore	Trouble	YR	0	3	311	0
Earth Ground Fault Trouble	Trouble	YP	0	1	310	0
Earth Ground Fault Trouble Restore	Trouble	YQ	0	3	310	0
Remote Annunciator Trouble	Trouble	ET	1	1	333	1
Remote Annunciator Trouble Restore	Trouble	ER	1	3	333	1
Phone Line 1 Trouble	Trouble	LT	1	1	351	1
Phone Line 1 Trouble Restore	Trouble	LR	1	3	351	1
Phone Line 2 Trouble	Trouble	LT	2	1	352	2
Phone Line 2 Trouble Restore	Trouble	LR	2	3	352	2
DACT Account Trouble	Trouble	RT	Account #	1	354	Account #
DACT Account Trouble Restore	Trouble	YK	Account #	3	354	Account #
DACT Failure Trouble	Trouble	IA	0	1	350	0
DACT Failure Trouble Restore	Trouble	IR	0	3	350	0
Walk Test Begin	Test	TS	Zone #	1	607	Zone #
Walk Test End	Test	TE	Zone #	3	607	Zone #
Auto Test Normal Standby	Test	RP	0	1	602	0
Auto Test Off Normal	Test	RY	0	1	608	0
Manual DACT test	Test	RX	0	1	601	0
System Programming Begin	Trouble	LB	0	1	627	0
System Programming Ended	Trouble	LS	0	1	628	0
System Reset	Trouble	OR	0	1	313	0
Initial Power Up Reset	Trouble	RR	0	1	305	0
Time or Date Changed	Test	JT	0	1	625	0

## 7. Compatible Devices for the HCA Series Panel

### 7.1 Compatible Conventional Initiating Devices

<b>Hochiki America Initiating Devices</b>		
		Maximum number per zone
<b>Detectors</b>		
SLV-24V	Photoelectric high velocity smoke detector	20
SLV-24N	Photoelectric high velocity smoke detector	20
SLR-24H	Photoelectric smoke/heat detector	20
SLR-24V	24VDC Photoelectric smoke detector	20
SLR-835	8 – 35VDC Photoelectric smoke detector	20
DSC-EA	Rate of rise heat detector	20
DCD-135	Fixed temperature rate of rise heat detector	20
DCD-190	Fixed temperature rate of rise heat detector	20
<b>BASES</b>		
NS6-224	43mA draw, 24V	20
NS4-224	43mA draw, 24V	20
NS6-100	150mA maximum, 24V	20
NS4-100	150mA maximum, 24V	20
<b>PULL STATION</b>		
HPS-SAK/HPS-DAH	Conventional Manual Pull Station	25
HPS-SAH/HPS-DAK	Conventional Manual Pull Station	25

### 7.2 Compatible Releasing Devices

<b>Compatible Releasing Devices</b>	
<b>Agent Releasing Actuator</b>	
TSP 131-035	Electrical Actuator/Solenoid
Sevo Systems – SOL EA45	Electrical Actuator/Solenoid
TLX Technologies – PA0036-3	Electrical Actuator/Solenoid
<b>Water Releasing Solenoids</b>	
Parker/Skinner - 73218BN4UNLVNOC111C2	Solenoid
Parker/Skinner - LV2L BX25	Solenoid
Parker/Skinner - X5H65100 24Volt	Solenoid
ASCO - T8210A107	Solenoid
ASCO - R8210A107	Solenoid
ASCO - 8210A107	Solenoid
ASCO - HV2185328	Solenoid
Victaulic - 753-E FireLock 300 psi	Solenoid
Viking –11591	Solenoid
<b>Releasing Abort Switch</b>	
0300-1000	Abort Switch
PB-SA (0500-06440)	Abort Switch
<b>Manual Release Switch</b>	
HPS-DAK-SR	Manual Release Pull Station
<b>Releasing EOL Module</b>	
0400-02590	EOL releasing module

### 7.3 Compatible Heat Detector Cable

<b>Compatible Devices</b>			
<b>Manufacturer</b>	<b>Models</b>	<b>Description</b>	<b>Maximum Length</b>
Proline Protection Systems LTD	TH 68	Fixed Temp. line type heat detector cable 68 <sup>o</sup> C (155 <sup>o</sup> F)	8,000 feet (2,438m)
Proline Protection Systems LTD	TH 88	Fixed Temp. line type heat detector cable 88 <sup>o</sup> C (190 <sup>o</sup> F)	8,000 feet (2,438m)
Proline Protection Systems LTD	TH 105	Fixed Temp. line type heat detector cable 105 <sup>o</sup> C (221 <sup>o</sup> F)	8,000 feet (2,438m)

### 7.4 Compatible Notification Appliances

The following devices from Gentex are compatible for use with the HCA control panel for synchronized applications on NAC 1, NAC 2, NAC 3, and NAC 4:

**Note:** *To determine the maximum quantity of notification appliances that can be used per NAC circuit use the worst case current consumption for the appliance models chosen and make sure the total current for all appliances does not exceed the maximum current rating of the HCA NAC circuit.*

<b>Gentex</b>	<b>Environment</b>	<b>Model Series</b>	<b>Description</b>	<b>Mount</b>
WSSPK Series	Outdoor	WSSPK24-15/75	Speaker Strobe	Wall
SSPK24WLP Series	Indoor	SSPK24WLP	Speaker Strobe	Wall
SSPKCLP Series	Indoor	SSPK24CLP	Speaker Strobe	Ceiling
Commander4 Series	Indoor	GCC24	Horn Strobe	Ceiling
Commander4 Series	Indoor	GCS24	Strobe	Ceiling
Commander3 Series	Indoor	GEC3-24	Horn Strobe	Wall
Commander3 Series	Indoor	GES3-24	Strobe	Wall
Commander3 Series	Indoor	GEH24	Horn	Wall
Commander2 Series	Indoor	GEC24	Horn Strobe	Wall
Commander2 Series	Indoor	GES24	Strobe	Wall
Commander2 Series	Indoor	GEH24	Horn	Wall
Outdoor Commander Series	Outdoor	WGEC24	Horn Strobe	Wall
Outdoor Commander Series	Outdoor	WGES24	Strobe	Wall
Outdoor commander Series	Outdoor	GEH24	Horn	Wall
GX91/GX93 Series	Indoor	GX93	Mini Horn	Wall

## **8. Warranty**

Hochiki America Corporation manufactured equipment is guaranteed to be free from defects in materials and workmanship for a period of three (3) years from date of original shipment. HOCHIKI will repair or replace, at its option, any equipment which it determines to contain defective material or workmanship. Said equipment must be shipped to HOCHIKI prepaid. Return equipment will be prepaid by HOCHIKI. We shall not be responsible to repair or replace equipment which has been repaired by others, abused, improperly installed, altered or otherwise misused or damaged or exposed to conditions outside the products specifications in any way. Unless previously contracted by HOCHIKI, HOCHIKI will assume no responsibility for determining the defective or operative status at the point of installation, and will accept no liability beyond the repair or replacement of the product at our factory service department. Please contact HOCHIKI's Sales department for proper procedure for claims and return of merchandise.

**Hochiki America Corporation  
7051 Village Drive, Suite 100  
Buena Park, CA 90621-2268  
1-800-845-6692  
technicalsupport@hochiki.com**

**End of Manual**

**Updated July 2013**