

CAVITY RESONATORS

UHF 440 - 512 MHz

BAND PASS

6554/SBC

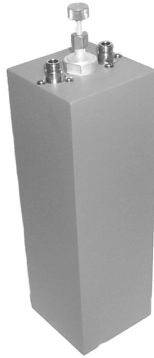

6567/SBC



6567/SBCH-2

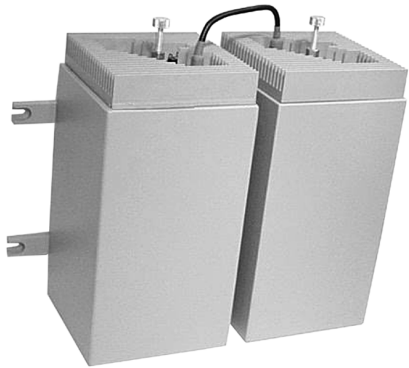

ELECTRICAL SPECIFICATIONS

Model Number	6554/SBC	6567/SBC	6567/SBCH
Frequency Band (MHz)	440-512	440-512	440-512
Input Power-See Appl. Notes	150 W	200 W	250 W
Insertion Loss	See Application Notes on Page 45		
Attenuation	See Charts Below	See Charts Below	See Charts Below
Impedance	50 Ω	50 Ω	50 Ω
VSWR	1.5:1 or Better	1.5:1 or Better	1.5:1 or Better
Electrical Length	1/4 λ	1/4 λ	1/4 λ
Temp Range	- 22 to +140 °F - 30 to +60 °C	- 22 to +140 °F - 30 to +60 °C	- 22 to +140 °F - 30 to +60 °C

MECHANICAL SPECIFICATIONS

Dim (d x w)		4" x 4"	7" x 7"	7" x 7"
Individual Cavity		102 x 102 mm	178 x 178 mm	178 x 178 mm
Dim (Height)	Inches	14" - 19"	14" - 19"	14" - 19"
Individual Cavity	Metric	356 - 483 mm	356 - 483 mm	356 - 483 mm
Connectors		N Female	N Female	N Female
Finish		EMR Gray	EMR Gray	EMR Gray
Ship Weight: Single		8 lbs. (3.7 kg.)	14 lbs. (6.9 kg.)	15 lbs. (6.9 kg.)
Dual		17 lbs. (7.8 kg.)	22 lbs. (10.0 kg.)	24 lbs. (10.9 kg.)
Triple		20 lbs. (9.1 kg.)	30 lbs. (13.7 kg.)	35 lbs. (15.9 kg.)

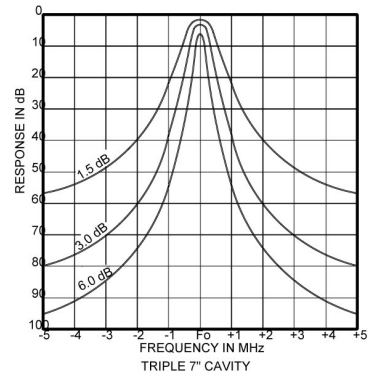
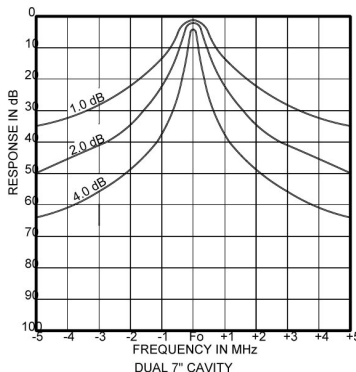
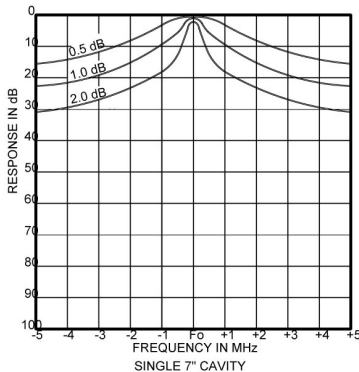
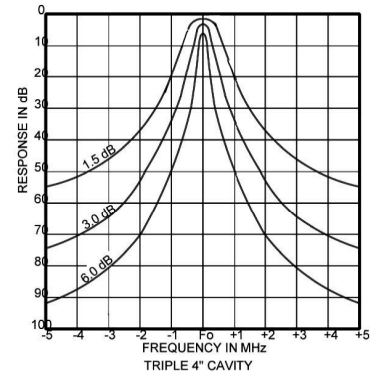
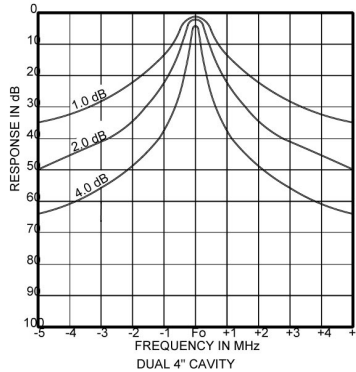
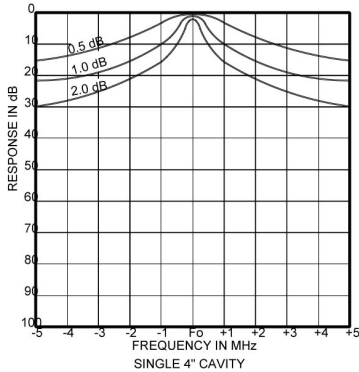

CAVITY RESONATORS

UHF 440 - 512 MHz

ELECTRICAL SPECIFICATIONS

Model Number	6577/SBCHF	65610/SBC
Frequency Band (MHz)	440-512	440-512
Input Power-See Appl. Notes	350 W	200 W
Insertion Loss	See Application Notes on Page 45	
Attenuation	See Charts Below	See Charts Below
Impedance	50 Ω	50 Ω
VSWR	1.5:1 or Better	1.5:1 or Better
Electrical Length	1/4 λ	1/4 λ
Temp Range	- 22 to +140 °F - 30 to +60 °C	- 22 to +140 °F - 30 to +60 °C

MECHANICAL SPECIFICATIONS

Dim (d x w)		7" x 12"	10" x 10"
Individual Cavity		178 x 305 mm	254 x 254 mm
Dim (Height)	Inches	19"	14" - 20"
Individual Cavity	Metric	483 mm	356 - 508 mm
Connectors		N Female	N Female
Finish		EMR Gray	EMR Gray
Ship Weight: Single		18 lbs. (8.2 kg.)	20 lbs. (9.1 kg.)
Dual		34 lbs. (15.5 kg.)	Contact Factory
Triple		65 lbs. (29.5 kg.)	Contact Factory

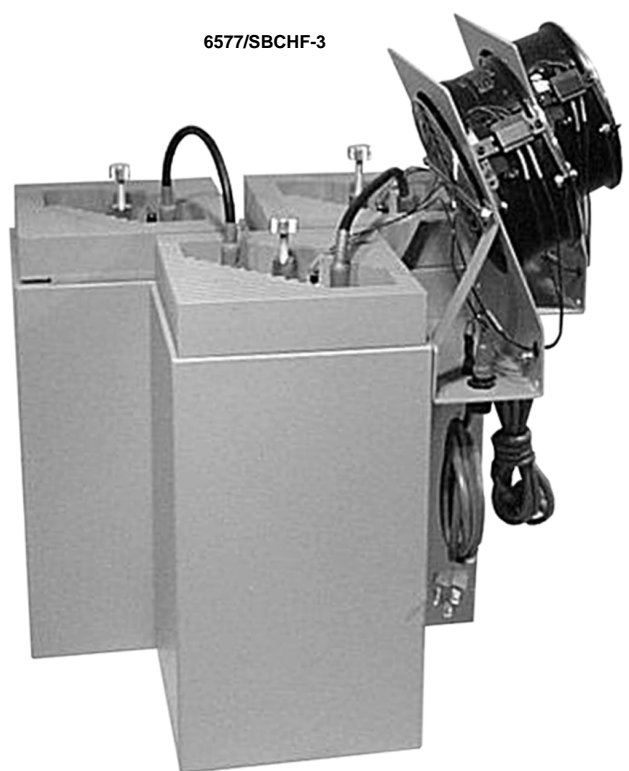

6577/SBCHF-3

BAND PASS

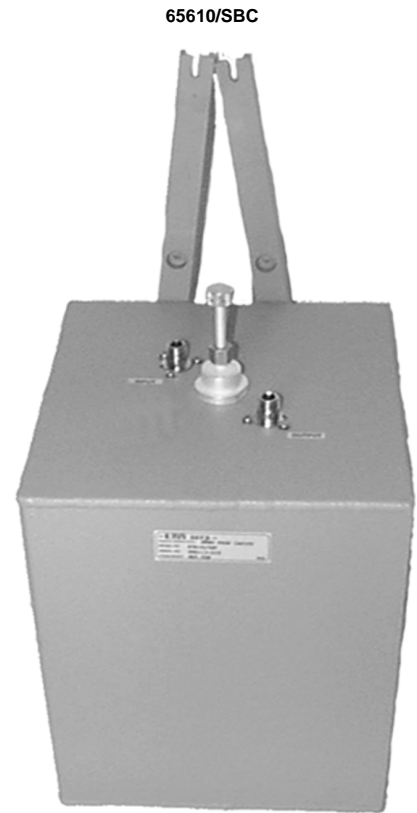
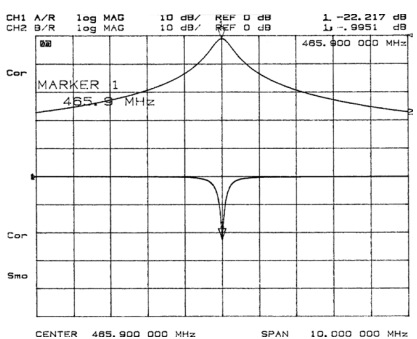
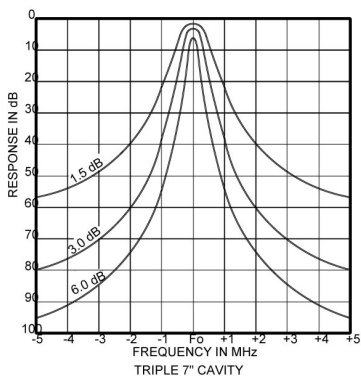
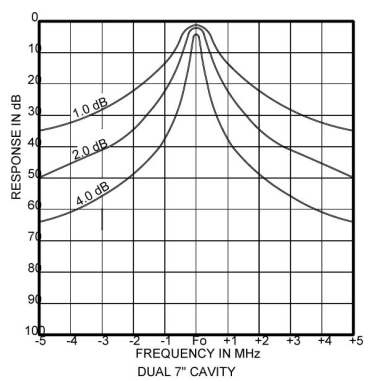
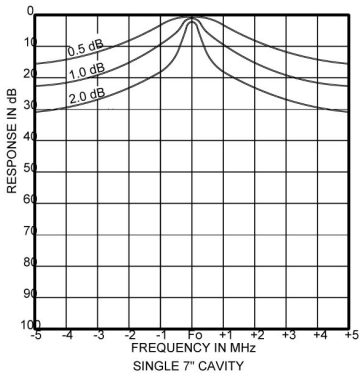

65610/SBC

CAVITY RESONATORS

UHF 440- 806 MHz

BAND PASS

65710/SBCH



65810/SBCHF

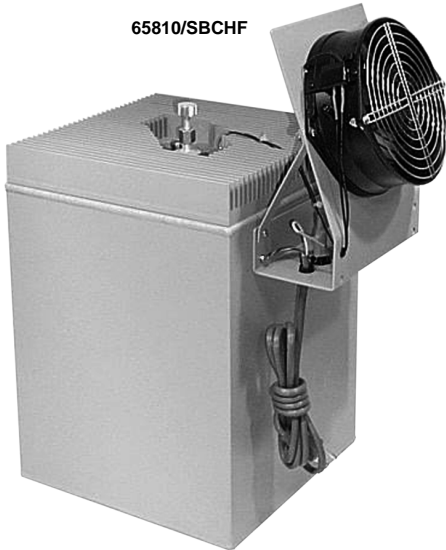

ELECTRICAL SPECIFICATIONS

Model Number	65710/SBCH	65810/SBCHF	Contact Factory (623) 581-2875
Frequency Band (MHz)	440-512	440-512	512-806
Input Power-See Appl. Notes	350 W	500 W	↑
Insertion Loss	See Application Notes on Page 45		
Attenuation	See Charts Below	See Charts Below	
Impedance	50 Ω	50 Ω	
VSWR	1.25:1 or Better	1.25:1 or Better	
Electrical Length	1/4 λ	1/4 λ	
Temp Range	- 22 to +140 °F - 30 to +60 °C	- 22 to +140 °F - 30 to +60 °C	
Single			
Dual	Contact Factory	Contact Factory	
Triple			

MECHANICAL SPECIFICATIONS

Dim (d x w)		10" x 10"	10" x 15"	
Individual Cavity		254 x 254 mm	254 x 381 mm	
Dim (Height)	Inches	14" - 20"	21"	
Individual Cavity	Metric	356 - 508 mm	534 mm	
Connectors		N Female	7/16 DIN	
Finish		EMR Gray	EMR Gray	
Ship Weight: Single		25 lbs. (11.4 kg.)	30 lbs. (13.7 kg.)	
Dual		Contact Factory	Contact Factory	
Triple		Contact Factory	Contact Factory	

65710/SBCH & 65810/SBCHF

