



PHOTOELECTRIC DETECTOR AX-330PLUS

Model	Detection range
AX-330PLUS	100 m / 330 ft.

FEATURES

- **LED indicator for beam alignment level:**

Accurate and reliable alignment can be easily achieved by using LED indicator located on the receiver.

The alarm indicating lamp is located in the front end of the inner housing and in viewfinder.

- **Aligned fine angle adjustment:**

By turning the dial, you can achieve vertical and horizontal optical adjustments.

- **Form C relay:**

Suitable for various applications.

- **Anti-frost structure:**

The front cover prevents fog and condensation from blocking the beams.

- **Beam interruption time adjustment:**

This feature allows you to select suitable beam interruption time for any environment.

- **Alignment-level monitor jack**

- **Optional accessories (not included):**

Heating unit (HU-2), Back cover (BC-2)

1 INTRODUCTION

1-1 BEFORE YOUR OPERATION

- Read this instruction manual carefully prior to installation.
- After reading, store this manual carefully in an easily accessible place for reference.
- This manual uses the following warning indications for correct use of the product, harm to you or other people and damage to your assets, which are described below. Be sure to understand the description before reading the rest of this manual.

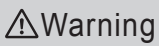
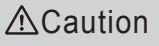







	Failure to follow the instructions provided with this indication and improper handling may cause death or serious injury.
	Failure to follow the instructions provided with this indication and improper handling may cause injury and/or property damage.



This symbol indicates prohibition. The specific prohibited action is provided in and/or around the figure.

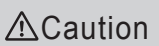

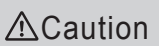
This symbol requires an action or gives an instruction.

	Do not use the product for purposes other than the detection of moving objects such as people and vehicles. Do not use the product to activate a shutter, etc., which may cause an accident. 
	Do not touch the unit base or power terminals of the product with a wet hand (do not touch when the product is wet with rain, etc.). It may cause electric shock.  
	Never attempt to disassemble or repair the product. It may cause fire or damage to the devices. 
	Do not exceed the voltage or current rating specified for any of the terminals during installation, doing so may cause fire or damage to the devices. 
	Do not pour water over the product with a bucket, hose, etc. The water may enter, which may cause damage to the devices. 
	Do not pour water over the product with a bucket, hose, etc. The water may enter, which may cause damage to the devices. 
	Clean and check the product periodically for safe use. If any problem is found, do not attempt to use the product as it is and have the product repaired by a professional engineer or electrician. 

1-2 PRECAUTIONS

Do not install the unit on an unstable surface.

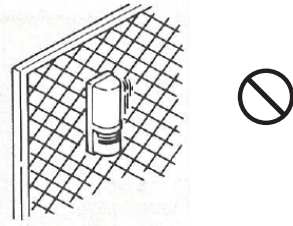

Do not install the unit in a location where trees, leaves, or other objects that may swing in the wind and block the beam.

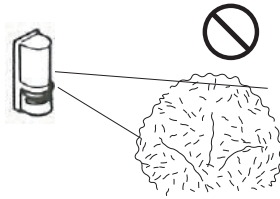

Do not install the receiver in a location where it is exposed to direct sunlight.

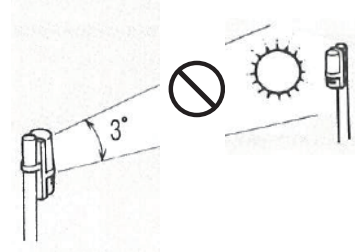

The mounting pole should have a solid basis with little movement at the top of the pole.

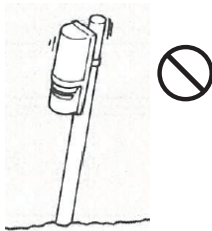

Avoid aerial wiring.

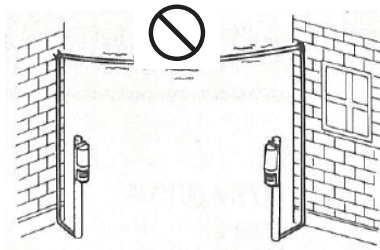

✓ For indoor application, the wiring installation is similar to that of telephone wirings or the Internet.

✓ For outdoor application, use wire conduit as far as possible. Some places require shielded wires or underground wiring.

⊘ This symbol indicates prohibition.

✓ This symbol indicates recommendation.

1-3 PARTS IDENTIFICATION

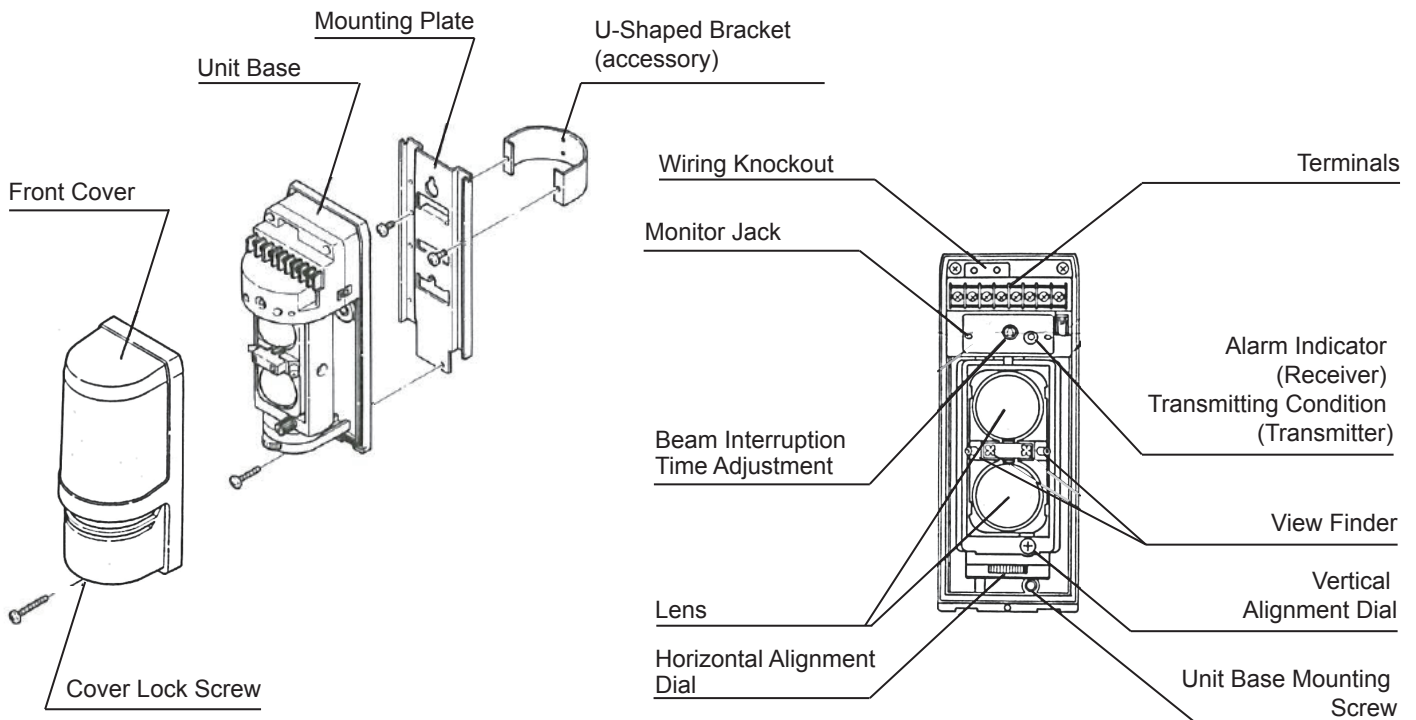

ACCESSORIES >>

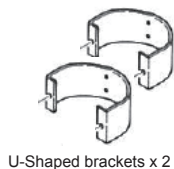

2 INSTALLATION

2-1 Normal installation

1 Range/ height/ angle

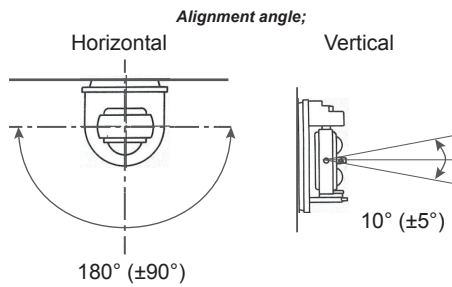
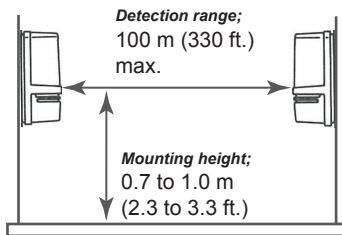

2 Pole installation

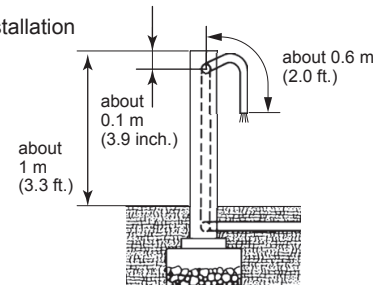

* Mounting pole; $\phi 43\sim 48$ mm (1 11/16"~1 7/8")
(Standard U.S. 1 1/2" pipe)

* The length of wiring cable out of the pole;
within 0.6 m (2.0 ft.)

* After finishing the pole installation,
align the transmitter and receiver with each other.

2-2 Installing method

1 Separating

Loosen the cover lock screw and
remove the front cover.

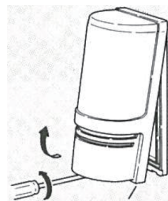

Loosen the unit base mounting screw and
slide the mounting plate downwards relative
to the unit base to remove it.

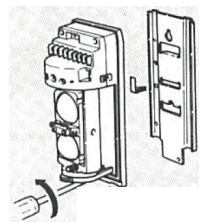

2 Mounting

Wall mounting

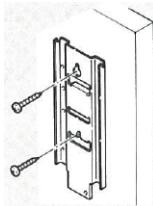

Pull out wires through the wiring
hole on the mounting plate and
fix the mounting plate on the wall
with screws.

Pole mounting

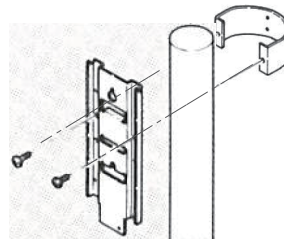

Place the U-shaped bracket on the mounting
pole, and pull out wires through the wiring
hole on the mounting plate and fix the
mounting plate on the U-shaped bracket
with screws.

Two unit mounting (back to back)

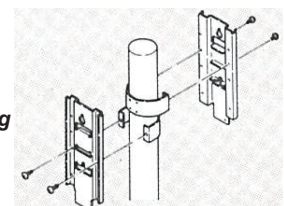

Fix two U-shaped brackets in layers on a pole, two
units can be mounted back-to-back on a pole at the
same height.

3 Wires and fixing

Pull the wires through the wiring holes of the unit base.
Connect the unit base to the mounting plate through the hook on the top of the unit base.
Push the unit base until it is fully engaged with the mounting plate.
Tighten the mounting screws on the bottom of the unit base.

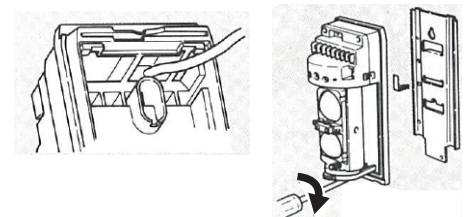

4 Connecting

Connect wires to the terminals.
(refer to Terminal and wiring
in Section 2-3).

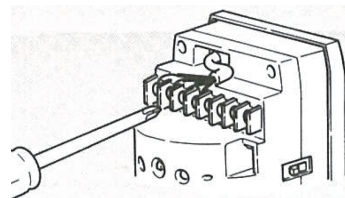

Knockout for the second wire

Dig out a hole on the right
side of the rubber bushing
marked with \odot , when it is
needed for the second wire.

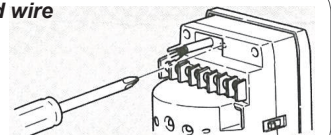

5 Place the front cover

Place the front cover after the optical
alignment and the walk test.
(Refer to optical alignment in Section 4).



Tighten the cover lock screw.

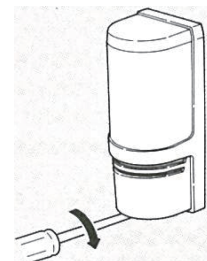

2-3 Terminal and wiring

1 Receiver

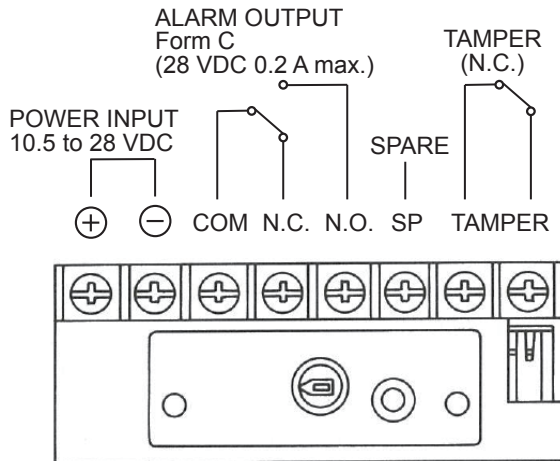

2 Transmitter

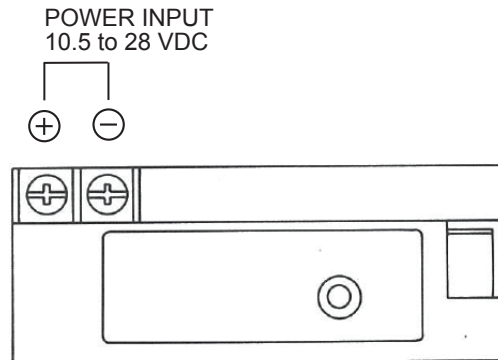

3 Wiring distance

- When using two or more units on one wire, the maximum length is obtained by dividing the maximum wire length listed right by the number of units.
(a detector = a receiver or a transmitter.)
- The power wire should not exceed that.

Wire size	m (ft.)	
	12 VDC	24 VDC
AWG 22 (0.33 mm ²)	500 (1 600)	2 500 (8 100)
AWG 20 (0.52 mm ²)	800 (2 600)	4 000 (13 000)
AWG 18 (0.83 mm ²)	1 200 (4 000)	6 000 (19 500)
AWG 16 (1.31 mm ²)	2 000 (6 500)	10 000 (32 500)

3 Beam interruption time adjustment

Beam interruption time adjustment is on the receiver unit. This function allows you to adjust the sensitivity of the device to fit to surroundings. A slower setting means less sensitivity.

Time adjustment (Receiver)					
Typical interruption time setting	Running (50 msec) 	Jogging (100 msec) 	Walk fast (200 msec) 	Walk slow (350 msec) 	Slow movement (500 msec)

⚠ Caution

The speed shown above is the maximum detectable speed for each setting. Faster speed will not be detected. For cases where birds, newspapers, or suspended matters may accidentally interrupt the beam, adjust the set value to a slower speed (longer interruption time).



4 Optical alignment

The reliability of photoelectric detector depends on the level of optical alignment.

Use the following method to ensure that the maximum voltage can be obtained from the monitor jack by means of a voltmeter.

4-1 Horizontal and vertical alignment

Observe the viewfinder of the transmitter and the receiver. Adjust the lens from horizontal and vertical directions, so that the other unit is in the center of the viewfinder.

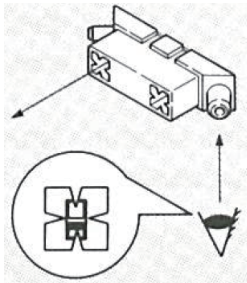

1 Horizontal alignment

Course adjustment

Fine adjustment

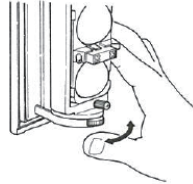
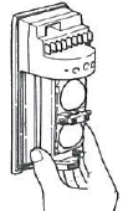

1. Align the position of the lens bracket by hand.
2. Look into the viewfinder, and turn the horizontal alignment dial for fine adjustment.

2 Vertical alignment

Fine adjustment

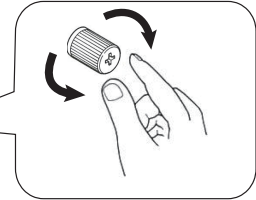
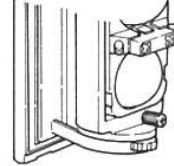

1. Look into the viewfinder, and turn the dial for fine adjustment by screwdriver or manually.
2. Right; upward / left; downward

4-2 Check by alarm LED

Remember to obtain the maximum voltage from the monitor jack by using a voltmeter so as to obtain the most stable beam (refer to Step 4-3).

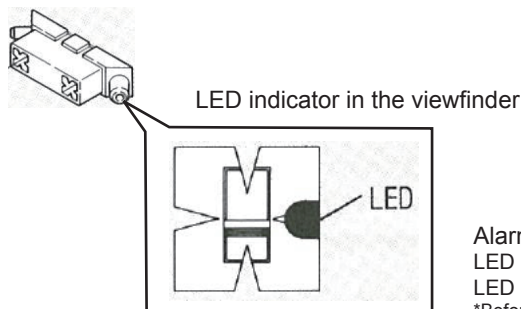

LED indicator in the front end of the receiver

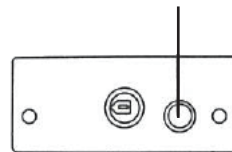

Alarm LED indicator status

LED ON: The beam energy emitted by the transmitter has not yet reached to the receiver.

LED OFF: The beam energy emitted by the transmitter has reached to the receiver.

*Before moving to the next step, confirm that LED indicator is OFF.

4-3 Carry out check from monitor jack

After adjustment by observing the LED indicator, use a voltmeter to check the voltage on the monitor jack to obtain the most stable beam.

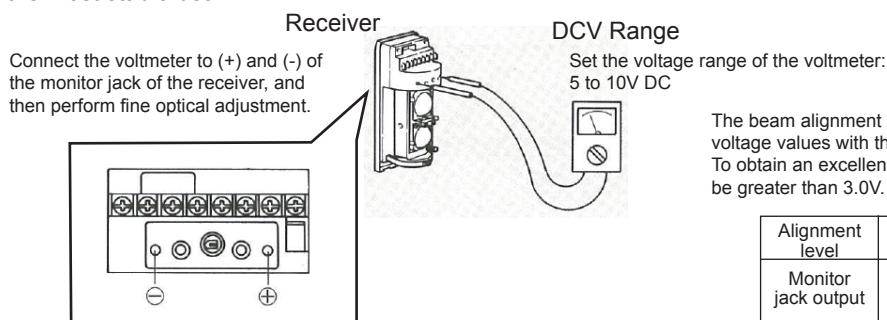

Connect the voltmeter to (+) and (-) of the monitor jack of the receiver, and then perform fine optical adjustment.

DCV Range

Set the voltage range of the voltmeter:
5 to 10V DC

The beam alignment level can be obtained by comparing the measured voltage values with the parameter values in the following table. To obtain an excellent alignment level, the measured voltage value must be greater than 3.0V.

Alignment level	Poor	Realign	Fair	Good	Excellent
Monitor jack output	0 V	▶ 1.5 V	▶ 2.5 V	▶ 2.7 V	▶ 3.0 V

Insert the probe of the voltmeter into the monitor jack in front end of the receiver.

Optical alignment for indoor use
The maximum voltage obtained from the monitor jack should be at least 2.5 V or more.

4-4 Walk test

1. Check that the alarm indicating lamp is OFF.
2. If the beam is not blocked and the indicating lamp is still ON, re-perform optical adjustment and check the wire connection (refer to Section 2-3).
3. After adjustment and normal operation of the device, perform walk test at least 3 locations as in the following :
 - In front of the transmitter
 - In front of the receiver
 - Midpoint between the receiver and the transmitter

5 Specifications

Model	AX-330PLUS
Detection method	Infrared photoelectric
Coverage	100 m / 330 ft.
Maximum arrival distance	1 000 m / 3 300 ft.
Beam characteristics	Pulsed infrared
Interruption period	50 to 500 ms (selectable)
Power supply	10.5 to 28 VDC
Current consumption (Transmitter + Receiver)	Normal operation 46 mA max.
Alarm period	2 sec. (± 1) nominal
Alarm output	Form C relay (28 VDC, 0.2 A max.)
Tamper switch	N.C., opens when the cover is removed (receiver only)
Operating temperature	-25°C to +55°C (-13°F to +131°F)
Environment humidity	95% max.
Alignment angle	Vertical: $\pm 5^\circ$, horizontal: $\pm 90^\circ$
Installation	Wall installation/pole installation
Weight (Transmitter + Receiver)	1 040 g (36.7 oz)

* Specifications and design are subject to change without prior notice.

6 Dimensions

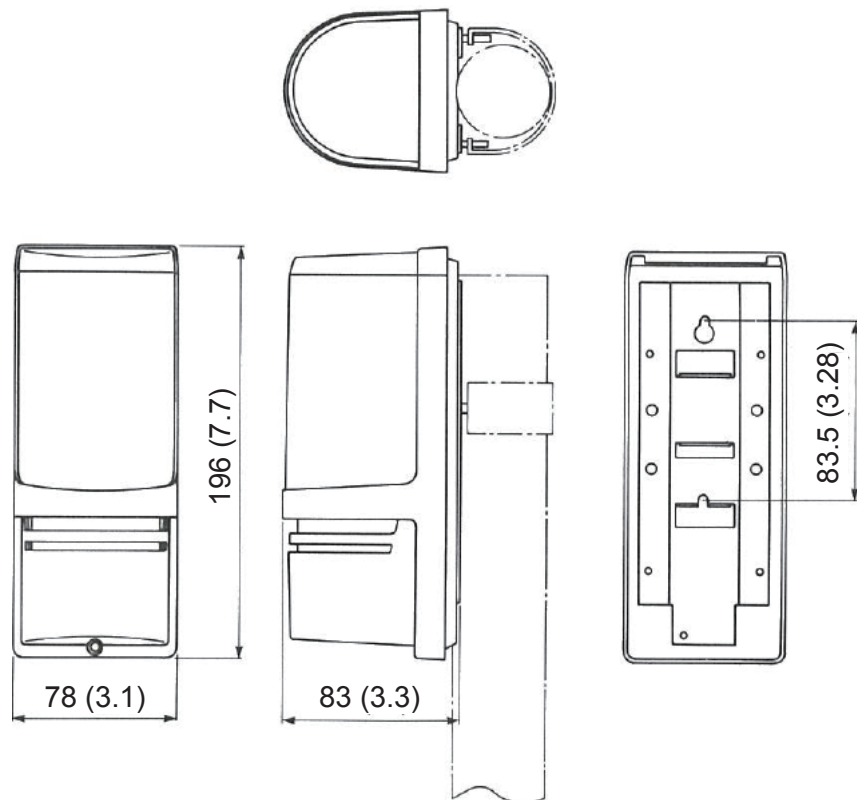

Unit: mm (inch)

7 Troubleshooting list

7-1 "No Action" on the transmitter or receiver after power has been applied.

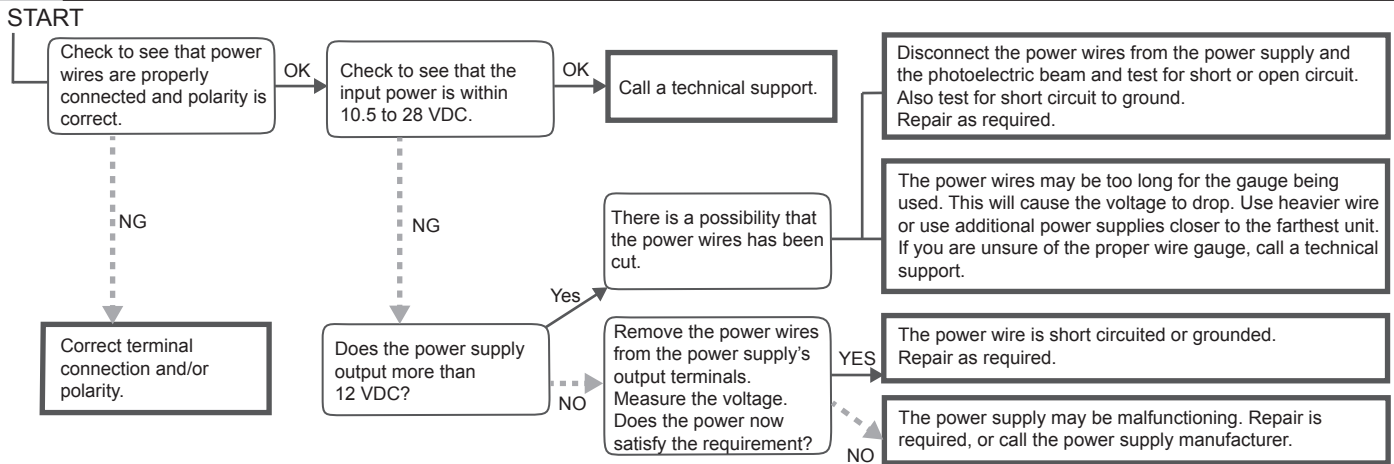

7-2 "No Action" on alarm zone even though the beams are completely blocked.

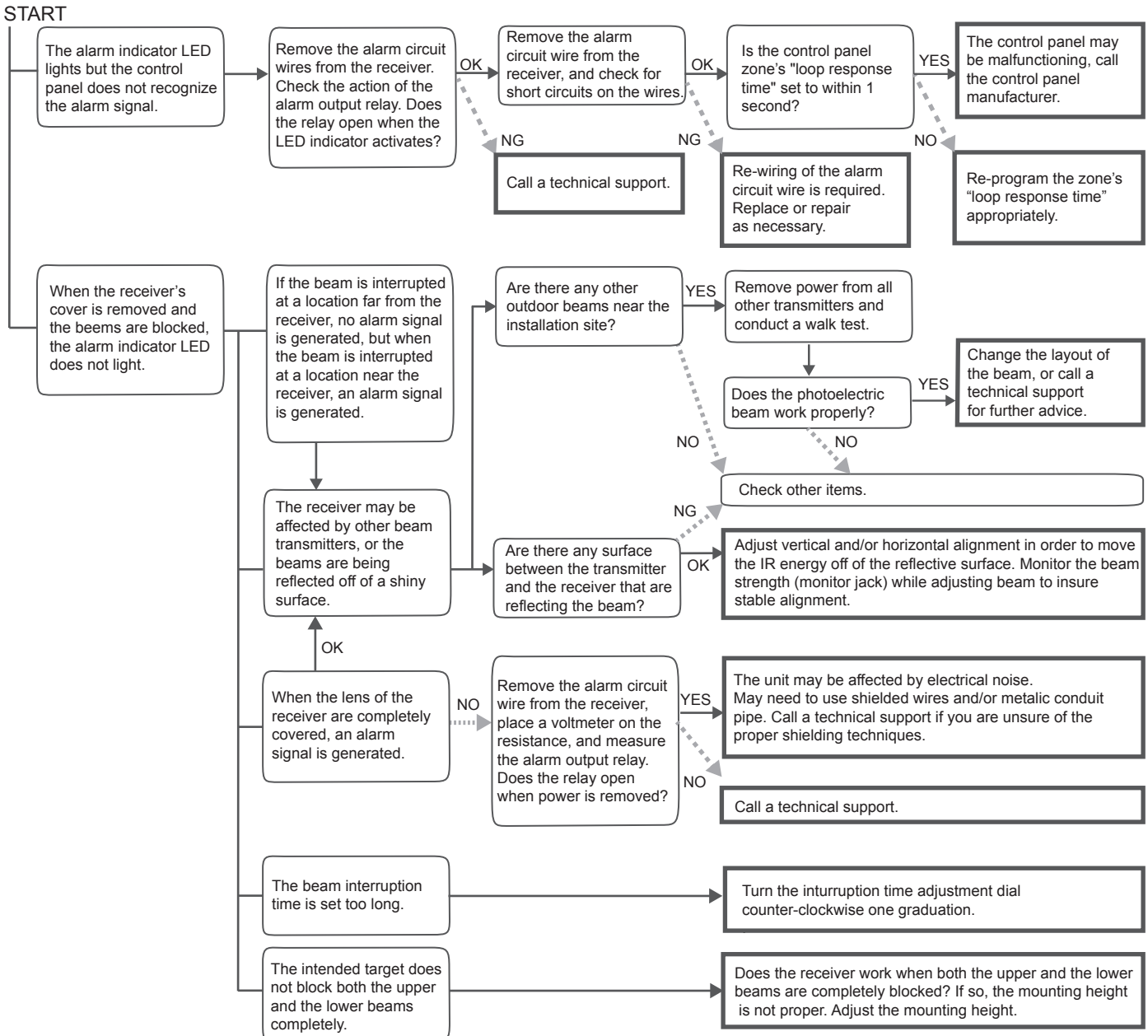

7-3 Alarm signal is being generated though beams are not blocked

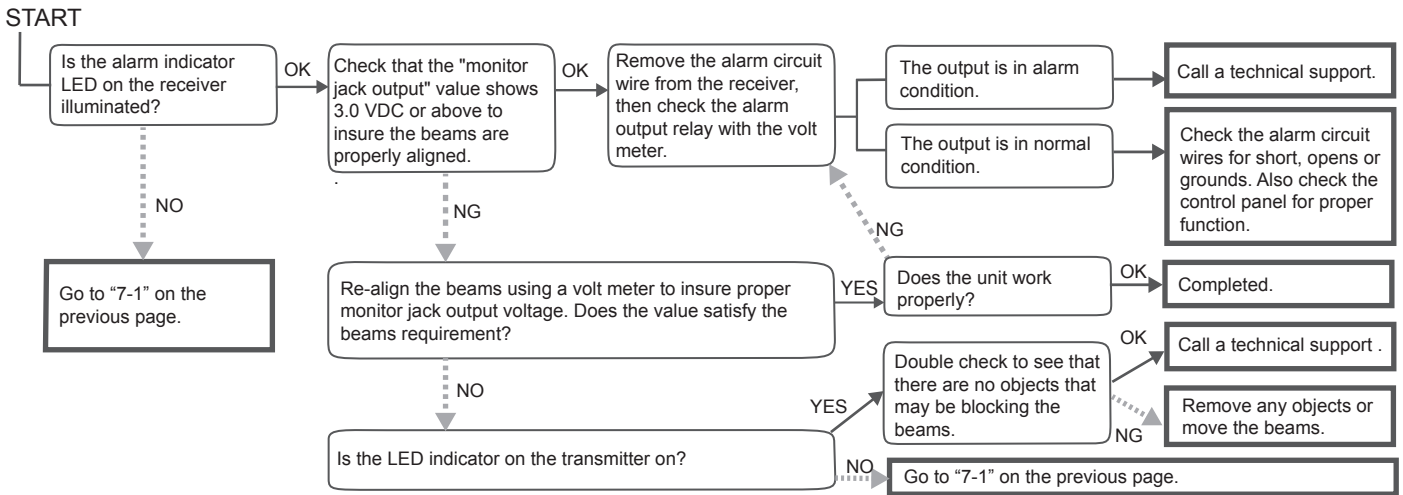

7-4 False activations

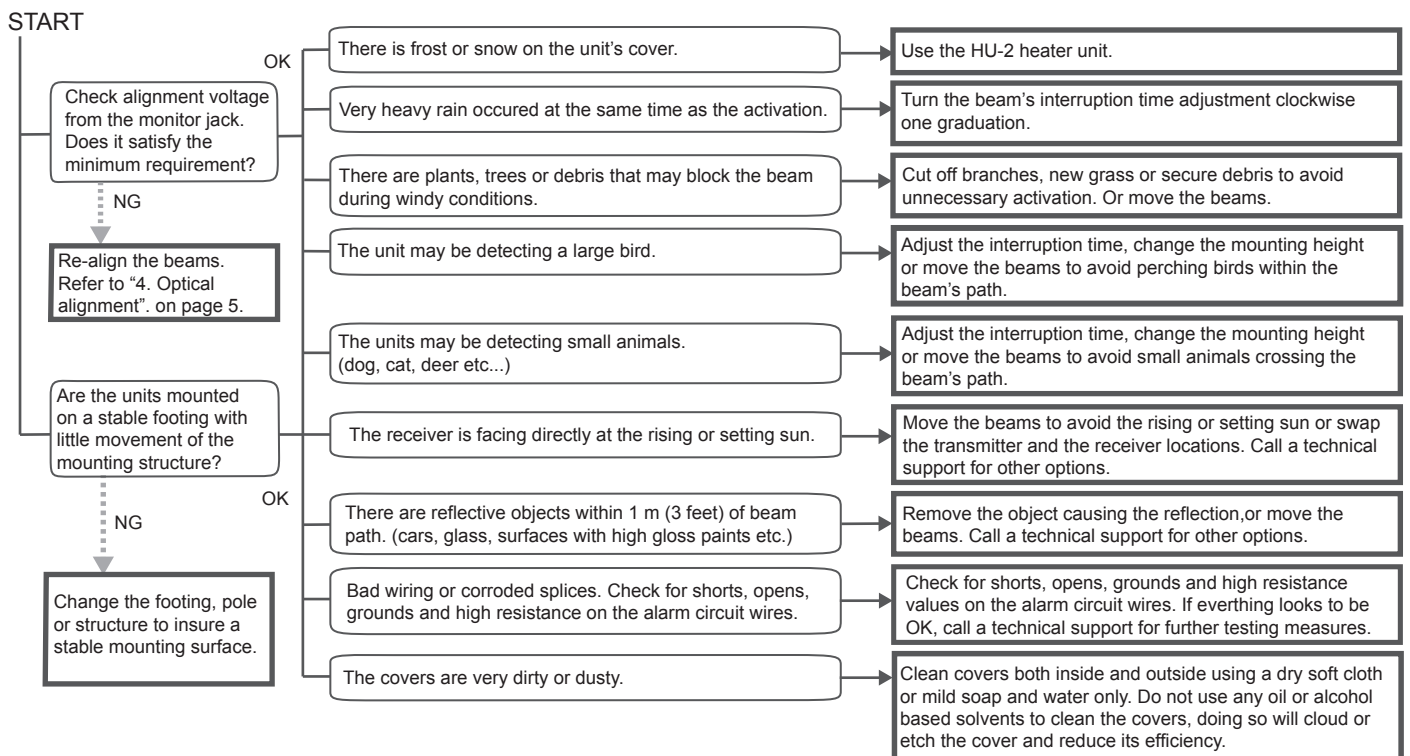

Important

The majority of false activations can be attributed to poor beam alignment. When aligning the outdoor beams, accept the value of no less than the "EXCELLENT" value for the most stable and trouble free system. Refer to the Installation Instructions for acceptable monitor jack voltage values.



Note;

This device is designed to detect moving objects and trigger alarms to the control panel.

It is only a part of the entire alarm system, and we do not bear the losses or consequences caused by invasions.



OPTEX

OPTEX CO., LTD. (JAPAN)

URL: <http://www.optex.net>

EU contact information

Manufacturer:
OPTEX CO., LTD.
5-8-12 Ogoto, Otsu, Shiga, 520-0101 JAPAN

Authorized representative in Europe:

OPTEX (EUROPE) LTD.
/ EMEA HEADQUARTERS
Marandaz House 1 Cordwallis Park,
Clivemont Road, Maidenhead, Berkshire,
SL6 7BU U.K.

OPTEX INC. (U.S.)

URL: <http://www.optexamerica.com>

OPTEX DO BRASIL LTDA. (Brazil)

URL: <http://www.optex.net/br/es/sec>

OPTEX (EUROPE) LTD. / EMEA HQ (U.K.)

URL: <http://www.optex-europe.com>

OPTEX TECHNOLOGIES B.V. (The Netherlands)

URL: <http://www.optex.eu>

OPTEX SECURITY SAS (France)

URL: <http://www.optex-security.com>

OPTEX SECURITY Sp.z o.o. (Poland)

URL: <http://www.optex.com.pl>

OPTEX PINNACLE INDIA, PVT., LTD. (India)

URL: <http://www.optex.net/in/en/sec>

OPTEX KOREA CO.,LTD. (Korea)

URL: <http://www.optexkorea.com>

OPTEX (DONGGUAN) CO.,LTD. SHANGHAI OFFICE (China)

URL: <http://www.optexchina.com>

OPTEX (Thailand) CO., LTD. (Thailand)

URL: <http://www.optex.net/th/th>

Copyright (C) 2017 OPTEX CO.,LTD.