



Installation and Operation Instructions 7660 Series LED Hybrid Beacons

The 7660 Series RotoLED™ beacon combines all the major benefits of the latest LED's with the unmistakable warning signal of a rotator, without compromising reliability. LED hybrid technology uses a brushless hybrid stepper motor to spin the reflector disk, reducing noise and eliminating the typical motor/gear drawbacks associated with conventional rotators. The 7660 also features eight LED's and TIR optic to provide SAE J845 Class I light output. Additional benefits include an extended, service free life, low amp draw and a 5 year warranty.



WARNING!

Failure to install or use this product according to manufacturer's recommendations may result in property damage, serious bodily/personal injury, and/or death to you and those you are seeking to protect!



Do not install and/or operate this safety product unless you have read and understand the safety information contained in this manual.

1. Proper installation combined with operator training in the use, care, and maintenance of emergency warning devices are essential to ensure the safety of you and those you are trying to protect.
2. Exercise caution when working with live electrical connections.
3. This product must be properly grounded. Inadequate grounding and/or shorting of electrical connections can cause high current arcing, which can cause personal injury and/or severe vehicle damage, including fire.
4. Proper placement and installation are vital to the performance of this warning device. Install this product so that output performance of the system is maximized and the controls are placed within convenient reach of the operator so that s/he can operate the system without losing eye contact with the roadway.
5. It is the responsibility of the vehicle operator to ensure during use that all features of this product work correctly. In use, the vehicle operator should ensure the projection of the warning signal is not blocked by vehicle components (i.e., open trunks or compartment doors), people, vehicles, or other obstructions.
6. The use of this or any other warning device does not ensure all drivers can or will observe or react to a warning signal. Never take the right-of-way for granted. It is your responsibility to be sure you can proceed safely before entering an intersection, driving against traffic, responding at a high rate of speed, walking on or around traffic lanes.
7. This equipment is intended for use by authorized personnel only. The user is responsible for understanding and obeying all laws regarding warning signal devices. Therefore, the user should check all applicable city, state, and federal laws and regulations. The manufacturer assumes no liability for any loss resulting from the use of this warning device.

Specifications:

Size: 7660 6.3" dia. x 6.2" high
7660-VM 8.0" dia. x 7.1" high

Weight: 7660 approx. 1.3 lbs.
7660-VM approx. 3.0 lbs.

Flash Rate:

Slow: 75 FPM
Fast: 120 FPM

Temp. Range: -30°C to +50°C

Input Voltage: 12 to 24 VDC systems

Input Current:

2.1 Amps Maximum (@12.8VDC)
Maximum power consumption: 26.9 watts (@12.8 VDC)

Installation & Mounting:

Important! This unit is a safety device, and it must be connected to its own separate, fused power point to assure its continued operation should any other electrical accessory fail.

Carefully remove the beacon and place it on a flat surface. Examine the unit for transit damage, and locate all parts. If damage is found, or parts are missing, contact the Distributor. Do not use damaged or broken parts.

Caution! When drilling into any vehicle surface, make sure that the area is free from any electrical wires, fuel lines, vehicle upholstery, etc. that could be damaged.

Permanent Mounting:

1. Select the desired location on a flat surface for the beacon to be mounted. The visibility of the LED hybrid flash and ease of wiring access should be taken into consideration in the selection of the mounting location.
2. Using the base gasket as a template, mark the three mounting hole locations (see FIGURE 1).
3. Drill the holes using a 7/32" drill size.
4. A fourth hole (3/8") may be drilled for wire access as shown in Figure 1, or the wires may be routed through the knock-out in the base for external access. The wires may be routed through the included grommet.
5. Connect the power wires as shown in the wiring section (see FIGURE 5).
6. Mount the beacon with included #10 hardware.

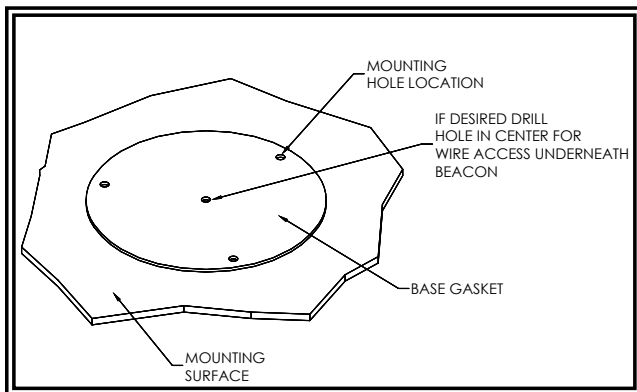

FIGURE 1

Pipe Mounting:

The 7660 series LED hybrid beacons use the A7660PF 1" NPT flange kit (not included) to allow for pipe mounting.

Temporary Mounting, Vacuum-Magnet Mount:

The Vacuum-Magnet Mount feature includes a suction cup on the bottom of the beacon, with a magnet inside of the suction cup, for a secure, temporary mount. The beacon should be placed in the center of the roof where the least amount of curvature occurs. Before installing, make sure the mounting surface is clean and there is no debris on the bottom of the beacon or on the roof of the vehicle, which could reduce the holding power of the suction cup and magnet. Place and remove the beacon without sliding to avoid scratching the paint on the vehicle. After placement, the beacon should adhere firmly to the surface. If the unit slides or moves easily, a proper installation has not been obtained. To release the vacuum, lift the tab to release the air-lock (see FIGURE 2). To protect the Vacuum-Magnet Mount assembly, return beacon to the box when not in use. Do not attempt to attach the beacon to an ice-covered surface.

WARNING!
Maximum recommended vehicle speed for safe operation using the Vacuum Mount model is 65 mph (104 km/h), when fitted to the center of a vehicle roof of steel construction. Higher speeds could cause the mount to fail, resulting in the beacon flying off of the vehicle, which could cause damage to other vehicles, and injury or death to the passengers. The vacuum-magnet mount is not intended as a permanent mounting for the beacon. The vacuum-magnet mount unit must be mounted on a flat smooth magnetic surface (i.e. no fiberglass, ribbed style roofs, etc.). Insure that the magnet is kept clean.

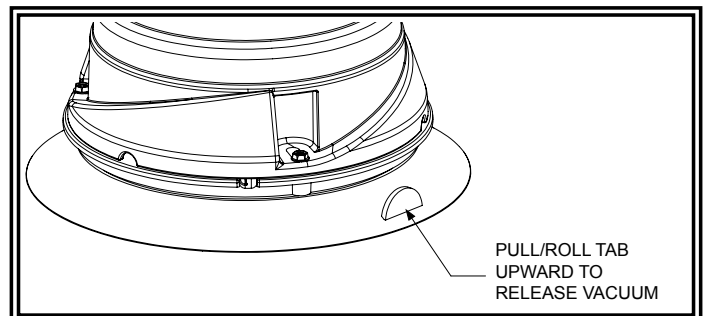

FIGURE 2

WARNING!
Failure to follow these instructions can result in fire or injury from excessive heat build up.

- Operator is responsible for ensuring cigarette adapter fits correctly into cigarette/auxiliary outlet used.
- For proper operation, verify cigarette/auxiliary outlet circuit is rated to supply a minimum of 10 amps. (See specifications section for rated current in amperes).
- Do not exceed the current rating for the cigarette lighter power outlet recommended by vehicle manufacturer.
- Keep cigarette lighter adapter, and outlet, clean and free of debris.
- Do not use the cigarette lighter adapter when wet.
- Insert cigarette lighter adapter fully into the outlet for proper connection.
- Grasp cigarette lighter adapter, NOT cord, to remove from outlet.
- Remove cigarette lighter adapter completely from outlet when light is not in use.

Vacuum-Magnet Mount Installation:

1. Trim the beacon wires to 3" or 7.5 cm long.
2. Cut off the tinned, bare wire portion off of the cigarette adapter cable.
3. Strip 3/8" or 9 mm of insulation from the wire ends on the beacon and the cigarette adapter cable.
4. Connect the black wire from the beacon to the cigarette adapter wire with the imprinted text using the supplied two position splicing connector.
5. For a 120 FPM rotation speed, connect only the red wire from the beacon to the cigarette adapter wire without the imprinted text using the supplied three position splicing connector. Trim and isolate the yellow wire.
6. For a 75 FPM rotation speed, connect the red and yellow wires to the cigarette adapter wire without the imprinted text using the supplied three position splicing connector.
7. Arrange the connectors in the base of the unit as shown in Figure 4 and route the cigarette adapter cable through the notch in the base.
8. Install the adapter plate onto the magnet mount using the three included 1/2" screws.
9. Position the magnet mount onto the base of the beacon and secure in place with the supplied 5/8" hex head screws.

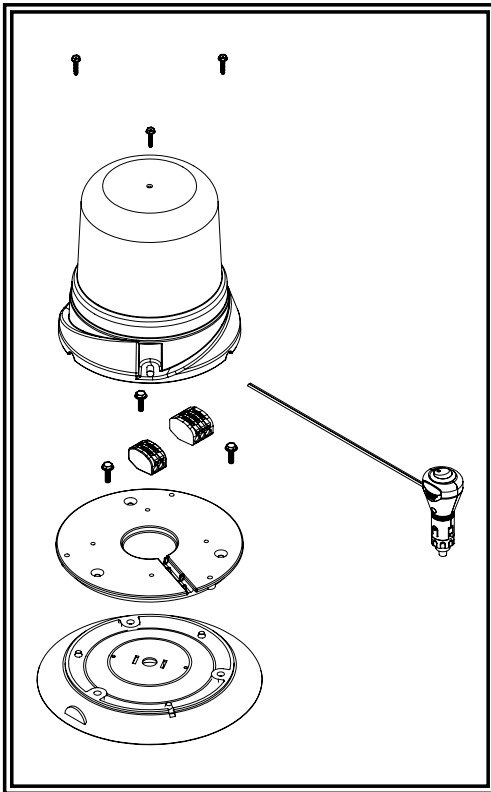

FIGURE 3

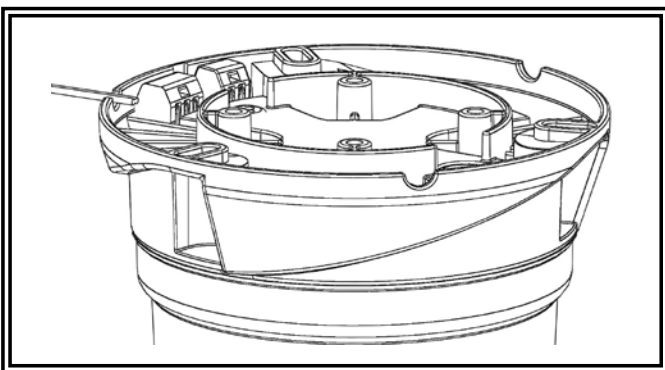

FIGURE 4

Wiring:

Important! Disable power before wiring the beacon.

The wiring for this configuration is as shown in FIGURE 5. All wiring should be a minimum of 18AWG. The positive line must have a 5 amp fuse, as shown. A switch may be used to control the on/off function. Route the ground wire directly back to negative battery terminal. Pack dielectric grease, such as Dow Corning 4, around each electric connection exposed to moisture or the ambient environment. For a 120 FPM rotation speed, connect only the red wire to (+)power and isolate the yellow wire. For a 75 FPM rotation speed wire the red and yellow wires together to (+)power.

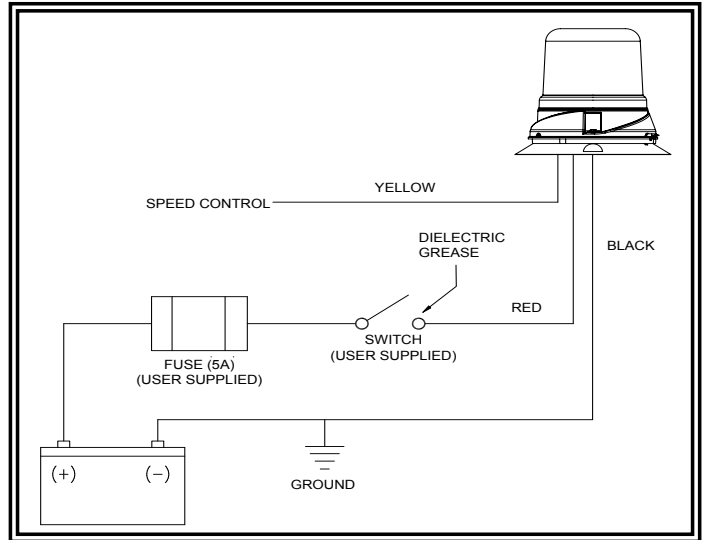

FIGURE 5

Accessory and Replacement Kits

R7660L*	Lens Replacement
A7660PF	1" Pipe Mount Flange
A7660VMK	Vacuum-Magnet Mount Kit

* where (X) indicates color:

A = Amber, B = Blue, C = Clear, G = Green and R = Red.

Electronics Controls Company "ECCO" (Manufacturer)

ECCO warrants that on the date of purchase, this product will conform to ECCO's specifications for this product (which are available from ECCO upon request). This Limited Warranty extends for 5 (five) years from the date of purchase.

DAMAGE TO PARTS OR PRODUCTS RESULTING FROM TAMPERING, ACCIDENT, ABUSE, MISUSE, NEGLIGENCE, UN-APPROVED MODIFICATIONS, FIRE OR OTHER HAZARD; IMPROPER INSTALLATION OR OPERATION; OR NOT BEING MAINTAINED IN ACCORDANCE WITH THE MAINTENANCE PROCEDURES SET FORTH IN ECCO'S INSTALLATION AND OPERATING INSTRUCTIONS VOIDS THIS LIMITED WARRANTY.

Exclusion of Other Warranties:

ECCO MAKES NO OTHER WARRANTIES, EXPRESSED OR IMPLIED. THE IMPLIED WARRANTIES FOR MERCHANTABILITY, QUALITY OR FITNESS FOR A PARTICULAR PURPOSE, OR ARISING FROM A COURSE OF DEALING, USAGE OR TRADE PRACTICE ARE HEREBY EXCLUDED AND SHALL NOT APPLY TO THE PRODUCT AND ARE HEREBY DISCLAIMED, EXCEPT TO THE EXTENT PROHIBITED BY APPLICABLE LAW. ORAL STATEMENTS OR REPRESENTATIONS ABOUT THE PRODUCT DO NOT CONSTITUTE WARRANTIES.

Remedies and Limitation of Liability:

ECCO'S SOLE LIABILITY AND BUYER'S EXCLUSIVE REMEDY IN CONTRACT, TORT (INCLUDING NEGLIGENCE), OR UNDER ANY OTHER THEORY AGAINST ECCO REGARDING THE PRODUCT AND ITS USE SHALL BE, AT ECCO'S DISCRETION, THE REPLACEMENT OR REPAIR OF THE PRODUCT, OR THE REFUND OF THE PURCHASE PRICE PAID BY BUYER FOR NON-CONFORMING PRODUCT. IN NO EVENT SHALL ECCO'S LIABILITY ARISING OUT OF THIS LIMITED WARRANTY OR ANY OTHER CLAIM RELATED TO THE ECCO'S PRODUCTS EXCEED THE AMOUNT PAID FOR THE PRODUCT BY BUYER AT THE TIME OF THE ORIGINAL PURCHASE. IN NO EVENT SHALL ECCO BE LIABLE FOR LOST PROFITS, THE COST OF SUBSTITUTE EQUIPMENT OR LABOR, PROPERTY DAMAGE, OR OTHER SPECIAL, CONSEQUENTIAL, OR INCIDENTAL DAMAGES BASED UPON ANY CLAIM FOR BREACH OF CONTRACT, IMPROPER INSTALLATION, NEGLIGENCE, OR OTHER CLAIM, EVEN IF ECCO OR A REPRESENTATIVE OF ECCO HAS BEEN ADVISED OF THE POSSIBILITY OF SUCH DAMAGES. ECCO SHALL HAVE NO FURTHER OBLIGATION OR LIABILITY WITH RESPECT TO THE PRODUCT OR ITS SALE, OPERATION AND USE, AND ECCO NEITHER ASSUMES NOR AUTHORIZES THE ASSUMPTION OF ANY OTHER OBLIGATION OR LIABILITY IN CONNECTION WITH SUCH PRODUCT.

This Limited Warranty defines specific legal rights. You may have other legal rights which vary from jurisdiction to jurisdiction. Some jurisdictions do not allow the exclusion or limitation of incidental or consequential damages.



833 West Diamond St
Boise, Idaho 83705

Customer Service

USA 800-635-5900

UK +44 (0)113 237 5340

AUS +61 (0)3 63322444

www.eccoesg.com