

Quad Photoelectric Beam Detector User Manual

SF50H SF150H SF250H

◆ Thanks for purchasing quad photoelectric beam detector, please read the user manual carefully before installation.

WARNING	Do not use the product for purposes other than the detection of moving objects such as people and vehicles. Do not use the product to activate a shutter, etc. which may cause an accident.
	Do not touch the unit base or power terminals of the product with a wet hand (do not touch when the product is wet with rain etc.) It may cause electric shock.
	Never attempt to disassemble or repair the product. It may cause fire or damage to the devices.
CAUTION	Do not exceed the voltage or current rating specified for any of the terminals during installation, doing so may cause damage to the devices.
	Do not pour water over the product with a bucket, hose, etc. The water may enter which may cause damage to the devices.
	Clean and check the product periodically for safe use. If any problem is found, do not attempt to use the product as it is and have the product repaired by a professional engineer or electrician.

1. Features

- Interruption time adjustable
- NO / NC relay outputs
- Integrated tamper switch, turns on when cover is moved.
- Frequencies selectable for long distance and stacking installation
- LED display signal grade for easy alignment
- Wide voltage and energy-saving design
- "And" "Or" technology
- Digital communication function
- FRESNEL lens
- IP65 Waterproof grade: IP65
- Alignment angle horizontally $\pm 90^\circ$, vertically $\pm 10^\circ$
- Digital filtering, high environment adaptability to eliminate false alarms
- Anti-beam interference, workable in harsh situations.

2. Part Description

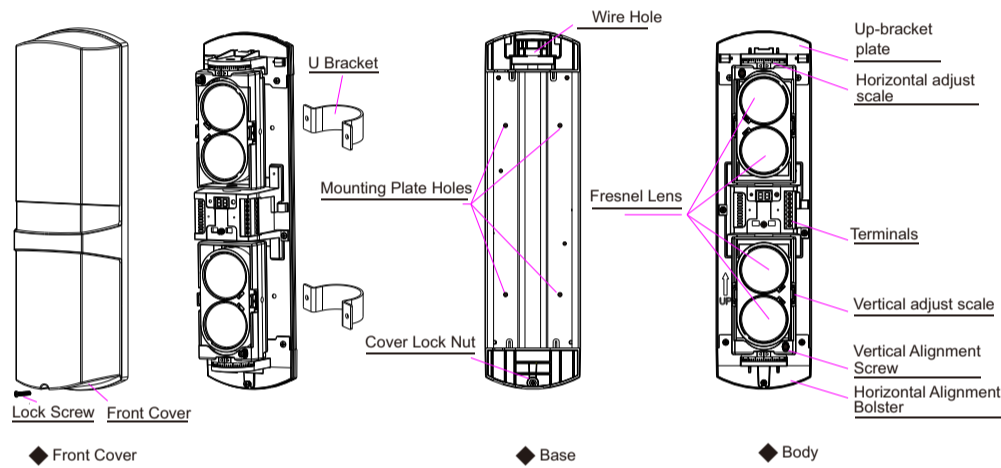

3. Installation notes

1. Please avoid below situations to assure performance

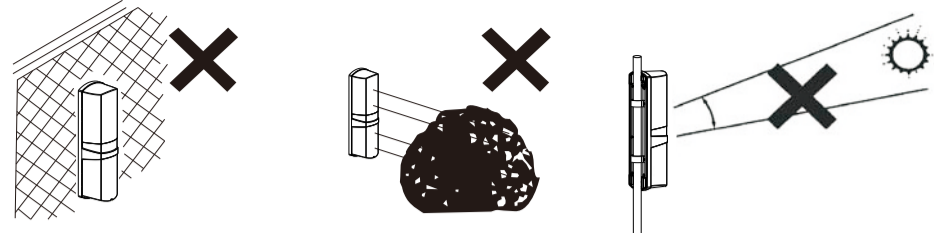

1. Do not install on the unsteady or not soiled surface

2. Do not install the unit where objects can block the beams like the plants and laundry can be moved by wind.

3. Prevent direct sunlight or fluorescent object entering into internal receiver.

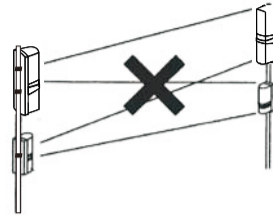

4. Avoid any other detector interference (stack installation only for same model)

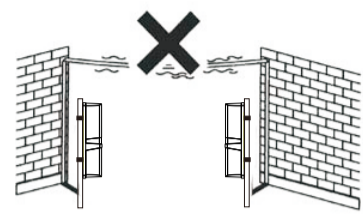

5. Avoid aerial wiring

2. Normal installation

◆ Detection distance

Model	Detection Distance	Beam Angle
SF50H	50m	1.6m
SF150H	150m	2.6m
SF250H	250m	4.4m

◆ Mounting height

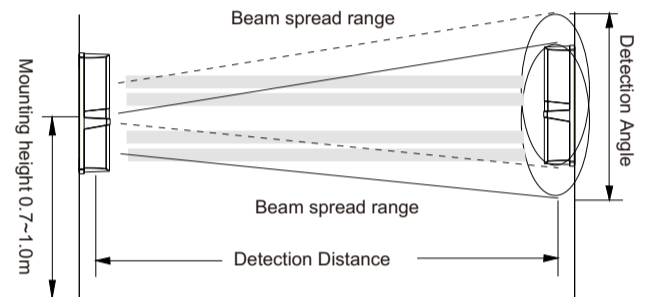

◆ Adjusting Angle

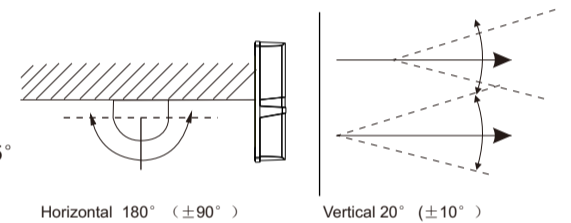

Notice: For best testing results, please avoid testing in 45°

4. Setting method

1. Wall mounting

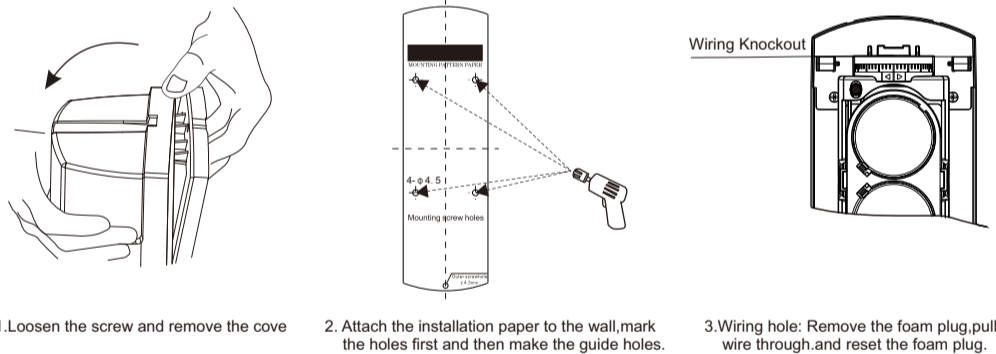

1. Loosen the screw and remove the cover

2. Attach the installation paper to the wall, mark the holes first and then make the guide holes.

3. Wiring hole: Remove the foam plug, pull wire through, and reset the foam plug.

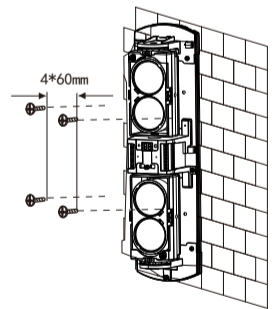

4. Drop into the four holes with the expansion pipes, fix them with screws.

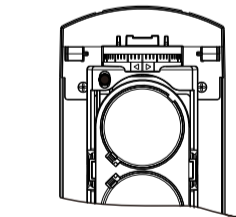

5. Connecting wires to the terminals (please refer to "beam alignment")

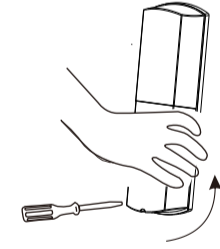

6. Review and reset the cover

2. Pole mounting

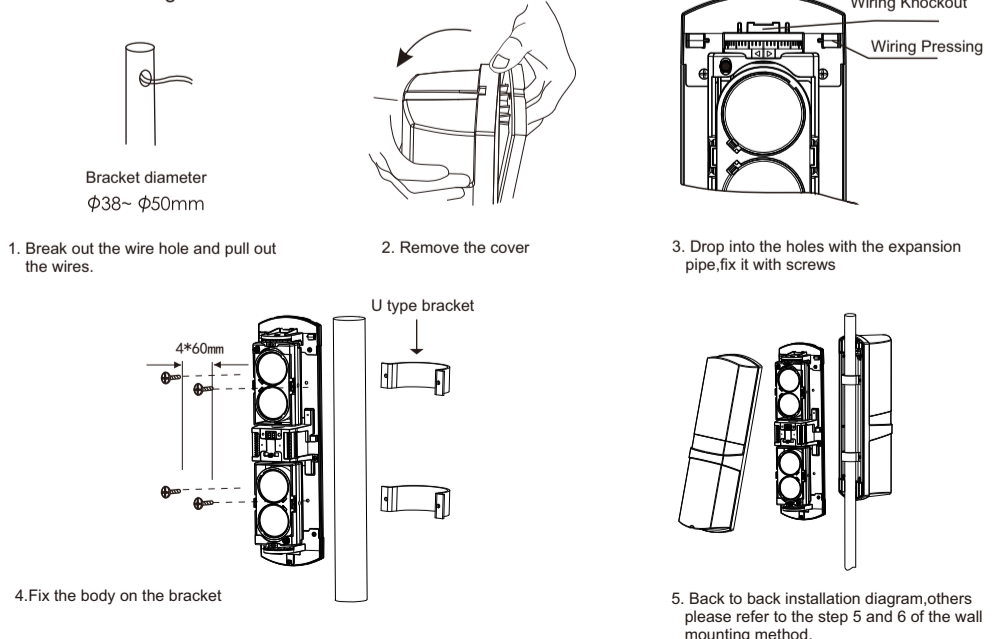

1. Break out the wire hole and pull out the wires.

2. Remove the cover

3. Drop into the holes with the expansion pipe, fix it with screws

4. Fix the body on the bracket

5. Back to back installation diagram, others please refer to the step 5 and 6 of the wall mounting method.

5. Connectors

Warning

when installation, don't connect the port with the voltage or current which is over the normal specification!

Transmitter

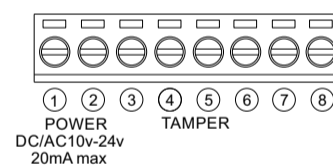

POWER DC/AC10v-24v 20mA max

Receiver

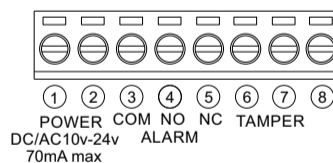

POWER DC/AC10v-24v 70mA max

Notes:

1. Power voltage input: DC/AC 10V-24V.
2. No heater in the package, please order if required.
3. The tamper switch is independent of other circuit; it would open if the cover was removed

Notes:

1. Power voltage input: DC/AC 10V-24V.
2. No heater in the package, please order if required.
3. The tamper switch is independent of other circuit; it would open if the cover was removed.
4. Relay connection point 1C 24VDC 0.5Amax

6. Connecting wires

1. Single connect: Control panel operating voltage DC12V. NC alarm output. Connecting to power supply parallel

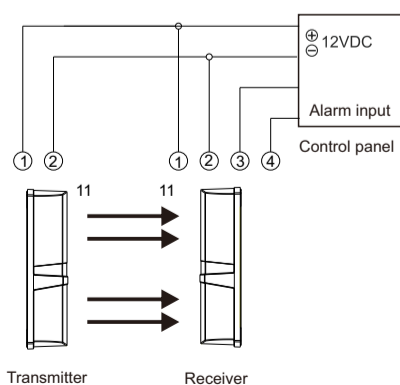

2. Stacked connect: Control panel operating voltage DC12V. NC alarm output series connect

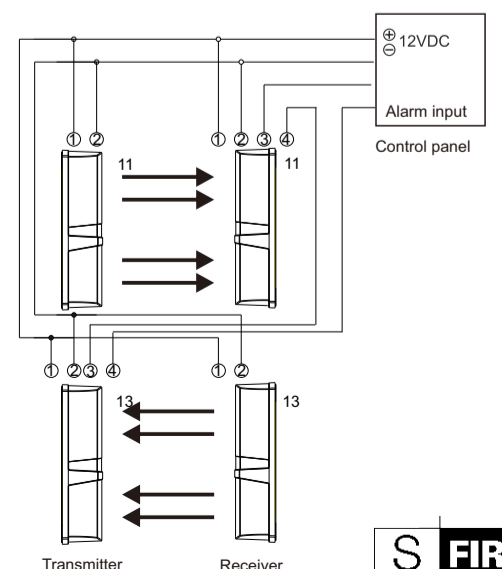

3. Control panel operating voltage DC12V. NC alarm output series connect as follows:

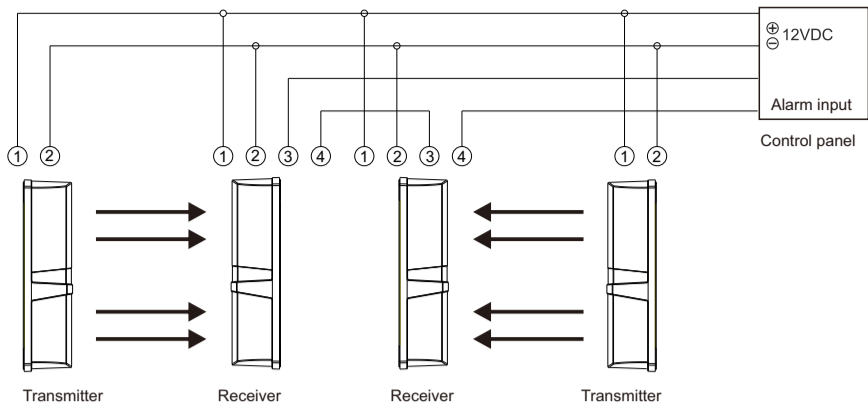

The distance between the power and the detector should not be longer than following.

Wire diameter	Length	DC12V	DC24V
0.5mm (diameter 0.8)		100m	500m
0.75mm (diameter 1.0)		150m	750m
1.0mm (diameter 1.2)		200m	1000m
1.5mm (diameter 1.4)		250m	1250m

Warning

1. The power line can not exceed the listed length.
2. When connecting multiple detectors, the required cable length is divided by the corresponding number of units listed.
3. Don't connect the port with the voltage or current which is over the normal specification!

7. Digital tube voltage indicator

Digital tube indicator (on the top of PCB shell)
3 button setting (on the bottom of PCB shell)

- (1) Adjust the beam frequency switch, make sure the frequency of transmitter must be the same as frequency of receiver.
- (2) Set the transmitter and receiver in 30 model. Adjust the screw and bracket until in alignment
- (3) Adjust the screw and bracket, set the receiver's voltage display mode to max. The indication of digital tube will change between "0.0" to "2.8". "0" indicates no signal and send alarm output. when optical axis aligning, the digital tube indicator should be not less than "2.5". then the upper two beams in alignment.
- (4) Set the transmitter and receiver in 31 model. repeat the (2)(3) steps, make the bottom two beams in alignment.
- (5) Then set the transmitter and receiver in 32 model, finished alignment.
- (6) Operation confirmation. Please make sure the alarm indicator is off before testing. If not please redo the alignment until the detector into normal alarm state.

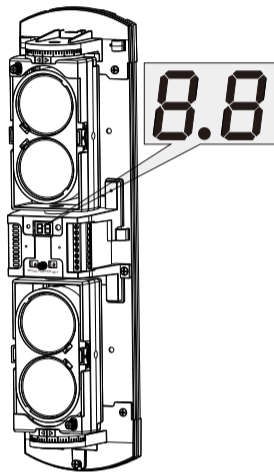

Signal strength	0-1.8 Realign
	1.9-2.2 Fair
	2.3-2.7 Good
	2.8 Best

8. Button setting

Introduction: the program setting is realized by two button (MODE, SET) and 2 bits digital tube display, easy to operate. MODE button: it is used for change parameters. Press once to change a parameter, single circulation conversion. SET button: it is used to set value of parameter under chosen MODE, Press once to change a parameter, single circulation conversion.

Transmitter: 1. MODE parameter setting sequence: frequency->debugging mode->detection mode->LED switch
2. Press button for 3 seconds to restore the MODE parameters factory setting (10, 32, 40, 50)

Receiver: 1. MODE parameter setting sequence: frequency->block infrared time->debugging mode->detection mode->LED switch->buzzer switch->signal degree
2. Press button for 3 seconds to restore the MODE parameters factory setting (10, 25, 32, 40, 50, 60, 0.0)

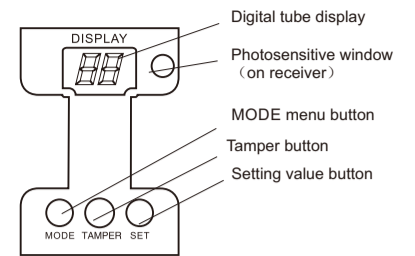

8.8 MODE parameter value setting

Parameters	Value setting	Description	Factory defaulted value	
Transmitter	Frequency 1	2 3 4 5	Setting value:0-3 refers to adjustable 4 kinds of frequency	10
	Debugging mode 3	0 1 2	0:only open above two infrared beams 1:only open below two infrared beams 2:open all four infrared beams	32
	Detection mode 4	0	Defaulted value is 0. Not editable	40
	LED switch 5	0 1	0:open LED 1:close LED	50
	Receiver	Frequency 1	0 1 2 3	Setting value:0-3 refers to adjustable 4 kinds of frequency
Block infrared time 2		0 1 2 3	Setting value:0-3 refers to adjustable 4 kinds of interruption infrared time	25
Debugging mode 3		0 1 2	0:only open above two infrared beams 1:only open below two infrared beams 2:open all four infrared beams	32
Detection mode 4		0 1	0:"and" mode 1:"or" mode	40
LED switch 5		0 1	0:open LED 1:close LED	50
Buzzer switch 6		0 1	0:open buzzer to make sounds 1.close buzzer	60
Signal degree	Two bit digital tube is used for display the signal degree, like 2.5 means the signal voltage degree is 2.5V			

MODE parameter setting introduction:

1. Frequency: using MODE button to change into this parameter; the digital tube displays the number among 10-13. Press SET button; the frequency increases one degree, single circulation among 10-13. 4 kinds of frequency selectable to avoid adjacent photoelectric beam sensors signal interference
2. Block infrared time: the digital tube displays the number among 20-23. Press SET button; the frequency increases one degree, single circulation among 20-23. 4 kinds of frequency selectable.
3. Debugging mode: the digital tube displays the number among 30-32. Press SET button; the frequency increases one degree, single circulation among 20-23. 3 kinds of frequency selectable: 30: only open above two infrared beams 31: only open below two infrared beams 32: open all four infrared beams
4. Detection mode: the digital tube displays the number among 40-41. Press SET button; the frequency increases one degree, single circulation among 40-41. 40:"AND" mode, means simultaneous interruption of four infrared beams to send alarm signal 41:"OR" mode, means simultaneous interruption of above two infrared beams or below two infrared beams to send alarm signal.
5. LED switch: the digital tube displays the number among 50-51. Press SET button; the frequency increases one degree, single circulation among 50-51. 50: open LED; 51: close LED
6. Buzzer switch: the digital tube displays the number among 60-61. Press SET button; the frequency increases one degree, single circulation among 60-61. 60: open buzzer 61: close buzzer
7. Signal degree: it uses voltage value to display. The higher voltage value; the stronger signal degree. the digital tube displays the number among 0.0-3.5. 1.8V signal display is photoelectric beam sensor normal work basic requirement. According channel LED indicator will become green.

Notes:

1. The detection mode and frequency of transmitter and receiver must be the same. After finishing debug above and below two infrared beams, please make debugging MODE into "32", or the product could not normally work.
2. If the tamper of transmitter and receiver is opened, the receiver will send alarm signal
3. After finish debugging, suggest closing LED indicator and buzzer to save energy, and opening tamper function.
4. If there is without pressing button operation within 30 minutes, the digital tube display will close; if pressing again, it will light.

9. Walk test

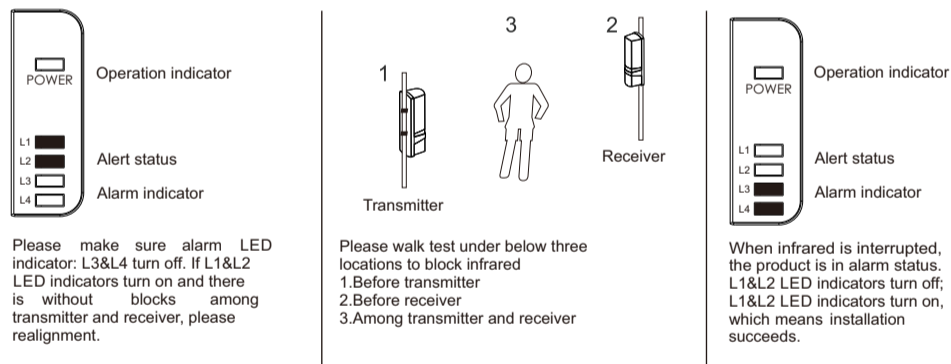

Please make sure alarm LED indicator: L3&L4 turn off. If L1&L2 LED indicators turn on and there is without blocks among transmitter and receiver, please realignment.

Please walk test under below three locations to block infrared
1. Before transmitter
2. Before receiver
3. Among transmitter and receiver

When infrared is interrupted, the product is in alarm status. L1&L2 LED indicators turn off; L3&L4 LED indicators turn on, which means installation succeeds.

Note: if the infrared is interrupted and the L1&L2 LED indicators do not turn on, please refer to item 10 to troubleshooting

10. Troubleshooting

Symptom	Possible cause	Remedy
Power on, but indicator LED does not light (off)	1. DIP switch is in the state of saving electricity 2. Power cable without voltage; broken circuit or short circuit; polarity is incorrect; beyond specified voltage; power cable exceeds the specified length.	1. Turn on the DIP switch 2. Check power adapter, circuit and voltage polarity; change adapter or power cable
When beam is blocked, alarm LED does not light and alarm	1. There are reflectors or other transmitters impacting receiver 2. 4 beams are not all blocked 3. Setting too long interruption time 4. Alarm output cable is fixed Incorrectly	1. Remove reflectors or close other transmitters; adjust receiver 2. Ensure 4 beams all blocked 3. Reduce interruption time 4. Check receiver terminal and output cable
When beam is not blocked, alarm LED lights and alarm	1. Beam is out of alignment; optical axis does not overlap 2. There are objects between receiver and transmitter 3. Frequency is incorrect 4. The cover is dirty or capped by snow, frost and ice 5. Transmitter dose not output 6. Model switch status is incorrect.	1. Adjust optical axis 2. Check objects between receiver and transmitter 3. Ensure the frequency of receiver and transmitter the same 4. Clean cover and use heater 5. Check the power, current and cable of transmitter 6. Check model switch setting
False alarm	1. Bad wiring and fluctuant power voltage 2. Movable blocks, like bird, paper, leaves 3. The installation base is unstable 4. Out of alignment 5. Infrared beam deviate optic axis	1. Check power, current and wiring 2. Change the installation location 3. Strengthen installation base 4. Adjust optical axis 5. Adjust the single optical axis

11. Specifications

Model	SF50H	SF150H	SF250H	
Detecting distance	(outdoor)	50m	150m	250m
	(indoor)	150m	450m	750m
Detecting distance(max)	300m	900m	1500m	
Detecting method	Simultaneous interruption of 4 infrared beams			
Interruption time	50ms, 100ms, 300ms, 700ms (adjustable)			
Frequencies	4 different frequencies (selectable)			
Power and voltage	12V-24VDC/AC			
Current consumption	150mA max			
Alarm cycle	2±1S			
Alarm output	Relay output (NC/NO) 1C. contact output.DC/AC30V/0.5A Max			
Tamper	NC. Works when cover is removed			
IP rating	IP65			
Operating temperature	-25°C~55°C			
Humidity	95% max			
Correction angle	Horizontally 180°(±90°);Vertically 20°(±10°)			
Install location	Indoor/outdoor, wall/pole			
Weight	2.20kg			

12. Dimensions

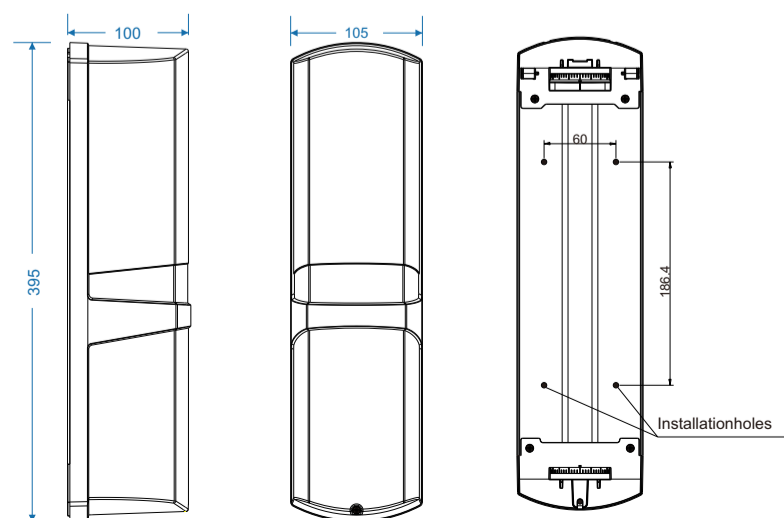

S FIRE

EL PASO, TX.
1630 Paisano DR.
(915)533-5119
EL PASO, TX. 79901 U.S.A