

THIS COPY IS PROVIDED ON A RESTRICTED BASIS AND IS NOT TO BE USED IN ANY WAY DETRIMENTAL TO THE INTERESTS OF PANDUIT CORP.

NOTES:

1. VISIT OUR ON-LINE CATALOG AT WWW.PANDUIT.COM FOR A LIST OF CURRENT PARTS APPLICABLE FOR USE WITH THIS PRODUCT.
2. DIMENSIONS IN () ARE METRIC.
3. ALL MATERIALS AND COMPONENTS USED MEET THE MATERIAL RESTRICTIONS OF RoHS (EUROPEAN DIRECTIVE 2011/65/EU ON THE RESTRICTION OF HAZARDOUS SUBSTANCES) AS PROPOSED BY THE RoHS TECHNICAL ADAPTATION COMMITTEE.
4. WEIGHT: 2.4 oz [68 g]
5. PART INCLUDES:
1- 12 POSITION ADAPTER PANEL W/ NYLATCHES
6. FOR USE WITH PANDUIT FPONE2, FPONE3, & FPONE4 ENCLOSURES. WILL NOT FIT OTHER PANDUIT ENCLOSURES.

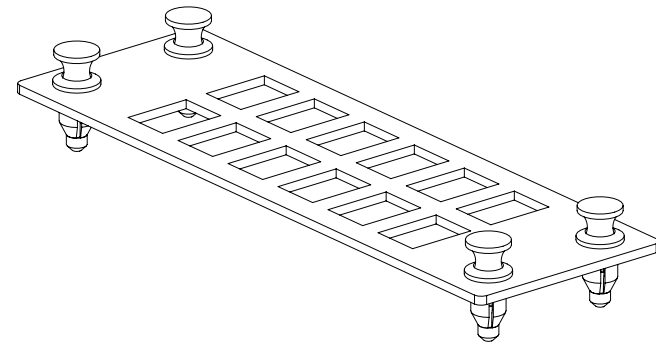
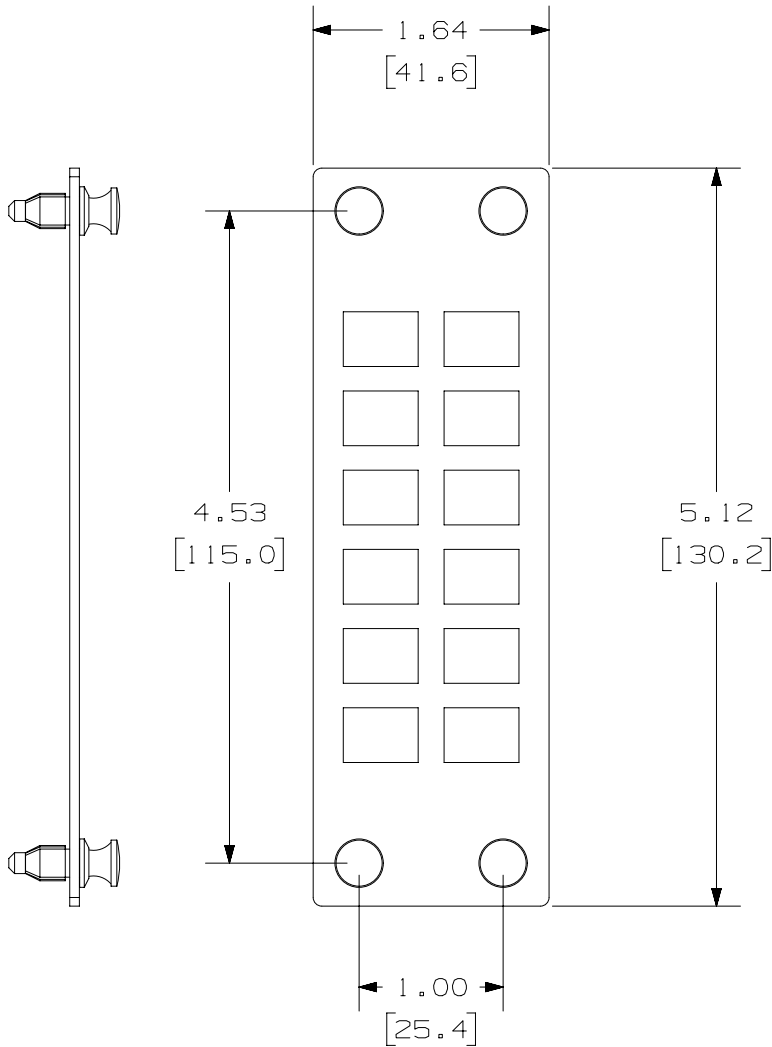

PART NUMBER		FPONEAP12		
TITLE				
ADAPTER PANEL PLATE FOR FPONE* FIBER ENCLOSURES				
CUSTOMER DRAWING				
ITEM REVISION NAME		00472EBH/03		
DATASET FILE NAME		00472EBH_DC/03A		
		THIRD ANGLE PROJECTION		
MATERIAL		XXXXXXXXXXXX		
DRAWING NUMBER		00472EBH-DC		
REV	DATE	BY	CHK	SCALE
03A	10-19-20	TWV	SCAL	3:4
DESCRIPTION		ECN		SIZE
RELEASED TO PRODUCTION		00472EBH		A
SHEET 1 OF 1				

A-SIZE CUSTOMER

2

1

2

1