



# **LED DOWNLIGHT**

---

**MODEL: EPI-DLS-15W**

LED Downlight, Ideal for illumination and decoration at home and public areas.

---

# OVERVIEW

- \* High brightness with lifetime more than 25,000 hours.
- \* New driver on board solution, cost effective.
- \* Stable quality, fire-proof material.
- \* Flicker-free, homogenous light.
- \* Uniform light output, no yellowing, no dark zone.
- \* Easy installation with fast connection.

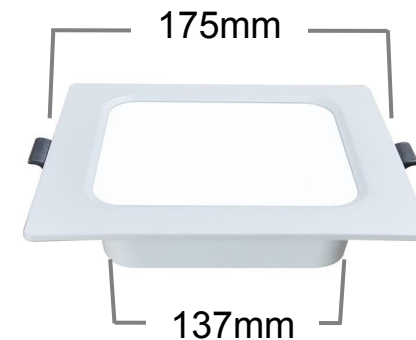
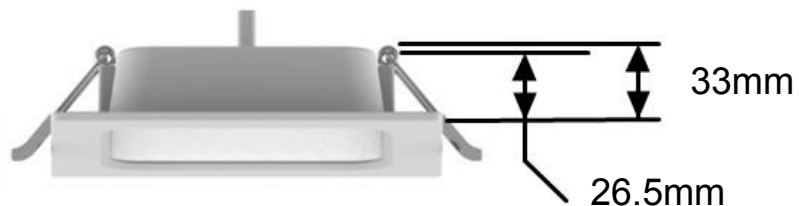

PHYSICAL DATA	
Dimension	175*175*26.5 mm
Cutout Diameter	140-150 mm
Lamp N.W.	148 g
LED Chip PCB	Aluminum
Material	PP Plastic + PS Cover
Installation	Recessed

ELECTRICAL DATA	
Wattage	15W
Power Factor	PF>0.5
Voltage	110VAC
Driver	Flicker-free
Output Efficiency	>90%
Surge Protection	1KV />2.5KV

OPTICAL DATA	
Lumen Flux	>1200LM
Lamp Efficacy	>80Lm/W
LEDs	SMD2835 (LM80)
CRI	>80
CCT	3000K /4000K /5000K /6500K
SDCM	<5
Beam Angle	120 Degree

LIFE DATA & OPERATING DATA	
Lifetime of Lamp	>25,000 hours (L70)
Lumen Maintenance	>90% after 2000 hours
Warranty	2 Years
Working Temperature	-15°C+50°C
Recommend Install Height	<3M

## APPLICATION

Lighting area like the home lighting-living room, corridor, bedroom or commercial lighting-shopping mall, restaurant, cafe etc.



## INSTALLATION

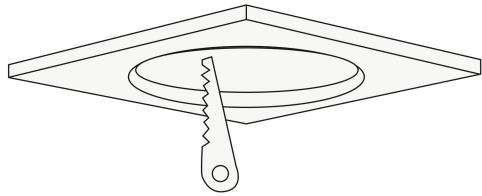

1 : Drill a hole on the ceiling

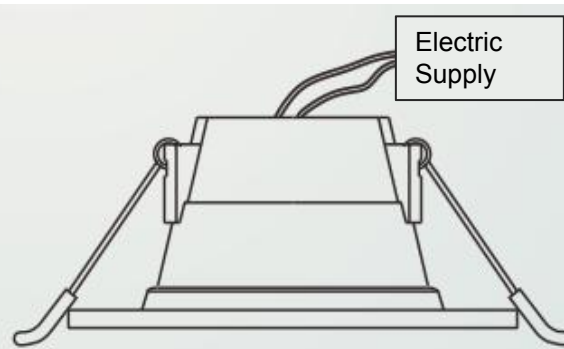

2: Connect to the power main line

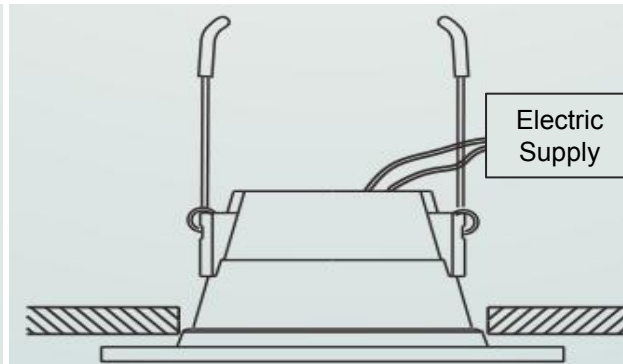

3: Press the buckle, upward install the lamp into the ceiling

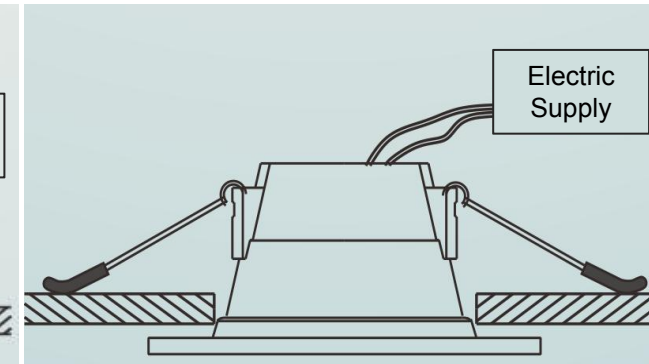

4: Fix the buckle and well finish the installation

## PACKING

Watts	Lamp Size	QTY/CTN	Box Size	CTN Size	N.W./CTN	G.W./CTN	CBM
15W	175*175*26.5 MM	30 PCS	192*31*180 MM	58*40*20 CM	4.44 KG	6.90 KG	0.046