



HID® Signo™ Biometric Reader 25B

User Guide

PLT-04900, B.1
March 2021

Powering
Trusted Identities

Copyright

© 2021 HID Global Corporation/ASSA ABLOY AB. All rights reserved.

This document may not be reproduced, disseminated or republished in any form without the prior written permission of HID Global Corporation.

Trademarks

HID GLOBAL, HID, the HID Brick logo, the Chain Design, iCLASS SE, HID Signo, Seos, HID Reader Manager, and HID Biometric Manager are trademarks or registered trademarks of HID Global, ASSA ABLOY AB, or its affiliate(s) in the US and other countries and may not be used without permission. All other trademarks, service marks, and product or service names are trademarks or registered trademarks of their respective owners.

Contacts

For additional offices around the world, see www.hidglobal.com/contact/corporate-offices.

Americas and Corporate	Asia Pacific
611 Center Ridge Drive Austin, TX 78753 USA Phone: +1 866 607 7339	19/F 625 King's Road North Point, Island East Hong Kong Phone: +852 3160 9833
Europe, Middle East and Africa (EMEA)	Brazil
3 Cae Gwyrdd Green Meadow Springs Cardiff CF15 7AB United Kingdom Phone: +44 (0) 1440 711 822	Condomínio Business Center Av. Ermano Marchetti, 1435 Galpão A2 - CEP 05038-001 Lapa - São Paulo / SP Brazil Phone: +55 11 5514-7100

HID Global Technical Support: www.hidglobal.com/support.

What's new

Date	Description	Revision
March 2021	Product rebrand from iCLASS SE® Signo 25B to HID Signo® Biometric Reader 25B	B.1

A complete list of revisions is available in [Revision history](#).

Overview	4
1.1 Hardware specifications	5
1.1.1 Biometric specifications	5
1.2 Wiring function and color codes	6
1.3 System connections	7
1.3.1 Power supply connection	7
1.3.2 Network connection	7
1.3.3 Standalone operating mode connections	8
1.3.4 Direct connection to PC	8
1.4 Hardware reset the Signo 25B	9
Fingerprint enrollment guidelines	10
2.1 General guidelines	11
2.2 Fingerprint enrollment best practices for Signo 25B	12
Acronyms and terminology	14

Section **01**

Overview

This section provides the HID® Signo™ Biometric Reader 25B wiring functions and color codes, together with system connection options.

HID Global is bringing the iCLASS SE® Signo 25B into the Signo™ family of readers and rebranding it as the HID Signo Biometric Reader 25B.

Both units share the same hardware. Refer to the *HID Signo 25B Firmware Release Notes* (PLT-04911) for information regarding new firmware updates.

Unless specified, Service Pack (SP) 2.2 features are available for current customers with Signo 25B (via upgrade) and new customers will now receive Signo 25B units.

1.1 Hardware specifications

For more detailed information relating to Signo 25B specifications refer to the Signo 25B product data sheet.

Hardware feature	Specification
Mounting	Mullion size mounted on door or any flat surface
Dimensions (width x length x depth)	1.93" x 7.95" x 2.17" (4.9 cm x 20.2 cm x 5.5 cm)
Product Weight (g)	13.04 oz (0.38 kg)
Operating Voltage Range (VDC)	12V DC
Operating Temperature	-4° F to 153° F (-20° C to 66° C)
Environmental Rating	IP67 Indoor/Outdoor and IK09 Impact Ratings
CPU and Memory	64 bit, 1.2 GB, Quad Core CPU. 8GB storage and 1 GB RAM
Panel connection	Pigtail, 18" (45.72 cm)
Communications	Ethernet (10/100), Wiegand, Open Supervised Device Protocol (OSDP) via RS485

1.1.1 Biometric specifications

Biometric feature	Specification
Image resolution / bit depth / Image area	500 dpi / 8 bit, 256 grayscale / 272 x 320 pixels
Template output format	ANSI 378 or ISO 19794-2
Supported users on device	Up to 250,000 users
1:1 Fingerprint Verification Authentication	Max. 50,000 users
1:N Fingerprint Identification Authentication	Max. 5,000 users
Card holders	Max. 250,000
Events storage	1,000,000
Live Finger Detection	Supported

1.2 Wiring function and color codes

The following shows Signo 25B wiring functions and color codes.

Important: Bond the ground wires between the Signo 25B power supply and the panel power supply.

Important: The 19 pigtail wires should be cut to size for wall mounted installations. **DO NOT** cut the Ethernet cable.

WARNING: Wiring the reader incorrectly may cause permanent damage to the reader.

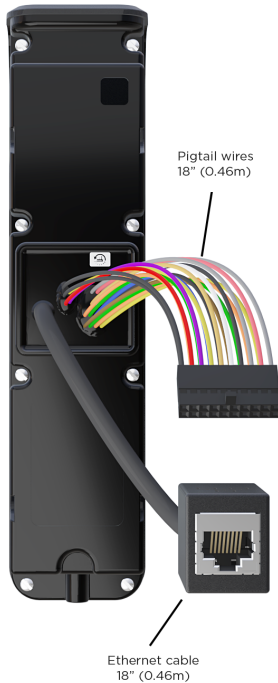

Function group	Wire color	Function	AWG	Max. length ¹
RS-485	Green	RS-485 A	24	4,000 ft (1,219 m)
	Tan	RS-485 B		
	Black	RS-485 Ground		
Relay (Reserved for future use)	Gray	Relay - Common	22	500ft (152 m)
	Yellow	Relay - Normally Open		
	Orange	Relay - Normally Closed		
Inputs (Reserved for future use)	Pink	REX Input (Supervised)		
	Gray	DPS Input (Supervised)		
	Black	Input Ground		
Weigand Port	Green	D0		
	White	D1		
	Brown	RED		
	Orange	GREEN		
	Yellow	BUZ		
	Blue	HOLD		
	Violet	TPR		
	Black	Ground		
DC Power	Red	Power +12 V		
	Black	Power Ground		

Function group	Connector	Function	Cable	Max. length
Network	RJ45 socket	Ethernet	CAT5/5E/6	328 ft(100 m)

- RS-485: Max. bus length: 4,000 ft - 24 AWG (1,219 m)
- Max. length between nodes: 1,640 ft - 24 AWG (500 m)
- Inputs: Reserved for controller mode only.

1.3 System connections

1.3.1 Power supply connection

Use a 12V DC power supply capable of at least 2A per device, with IEC/EN 60950-1 approval. If additional power consuming devices are included, make sure to use a power supply that is able to supply the total power needed for all connected devices.

Note: It is best practice to use separate power supplies for the Signo 25B and the electric locks.

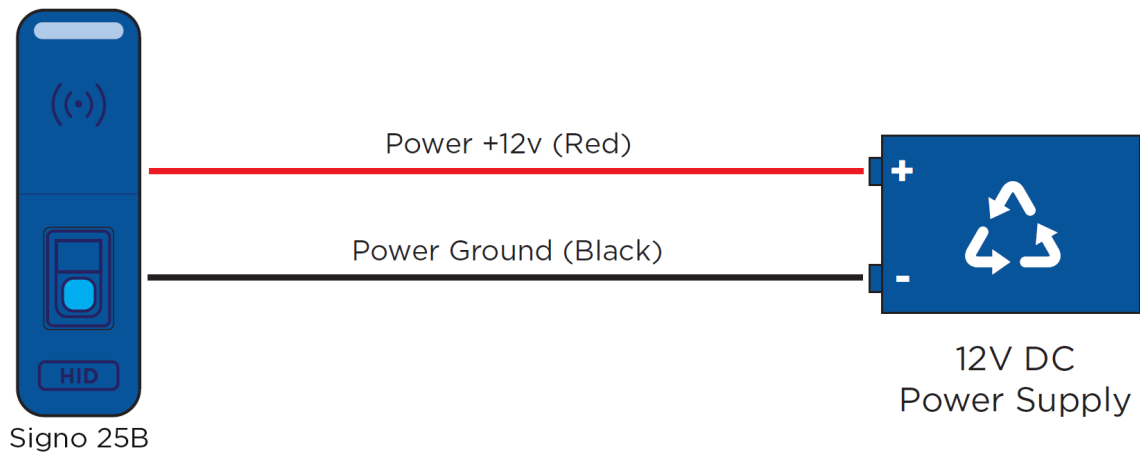

1.3.2 Network connection

Network connection to a network that has a server or a router configured for DHCP.

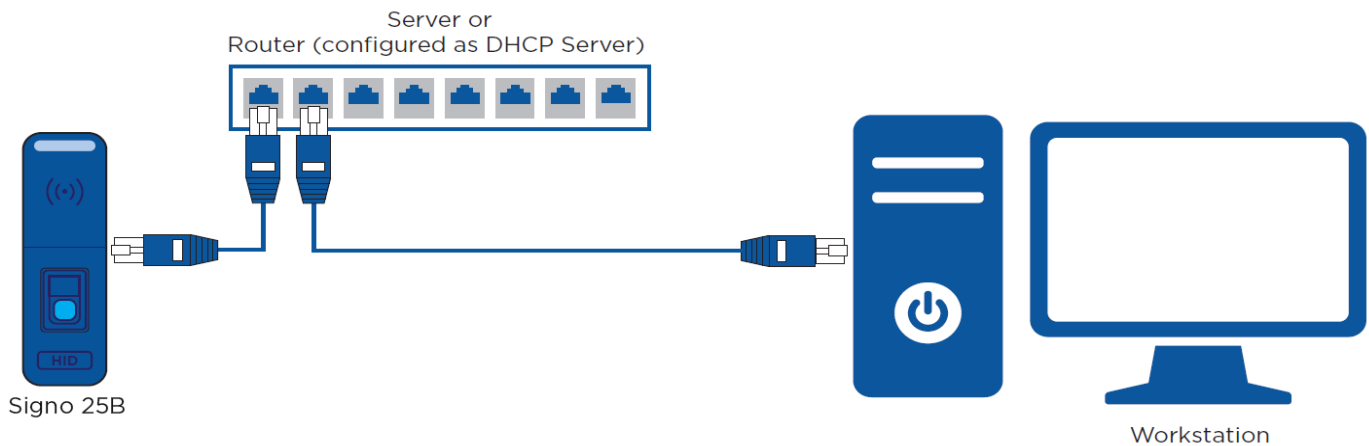

1.3.3 Standalone operating mode connections

Signo 25B devices can be used in standalone operating mode.

Note: Limited to SDK partners.

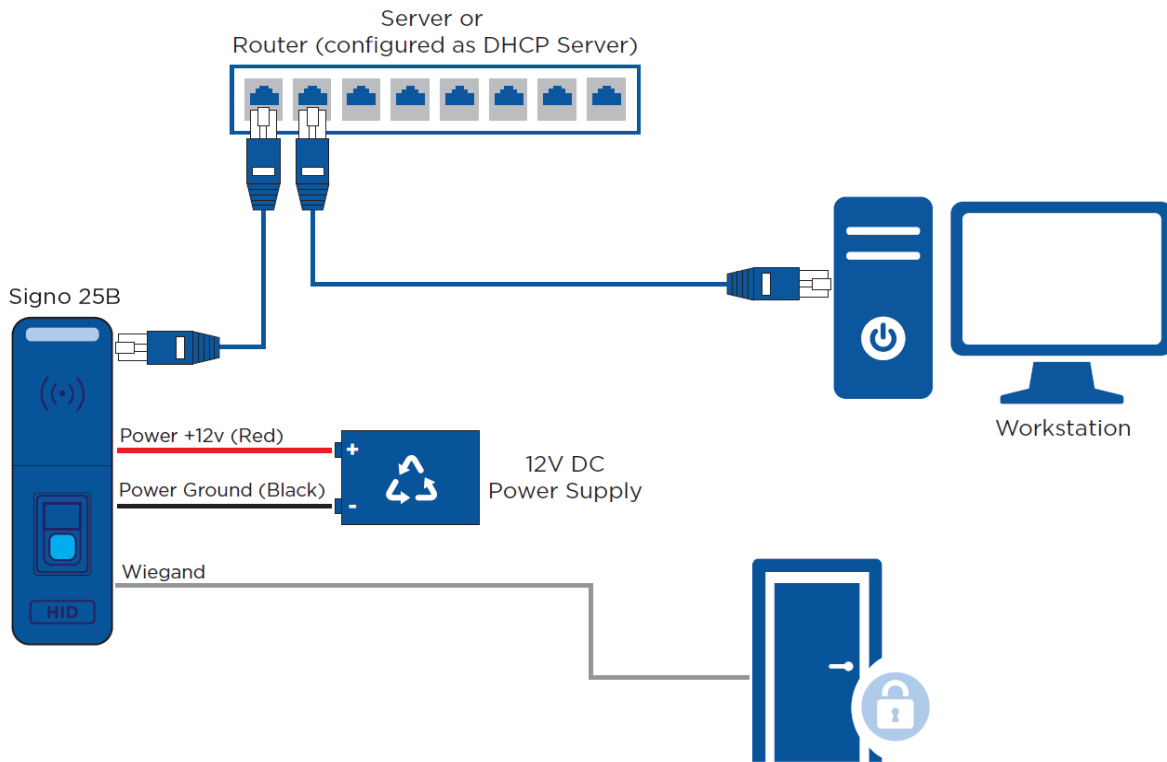

1.3.4 Direct connection to PC

Direct connection to PC using an auto assigned IP address or a static IP address.

Note: It can take up to five minutes for this connection type to configure.

Note: Supported network installations can be found in the *HID Biometric Manager Administration Guide* (PLT-04029).

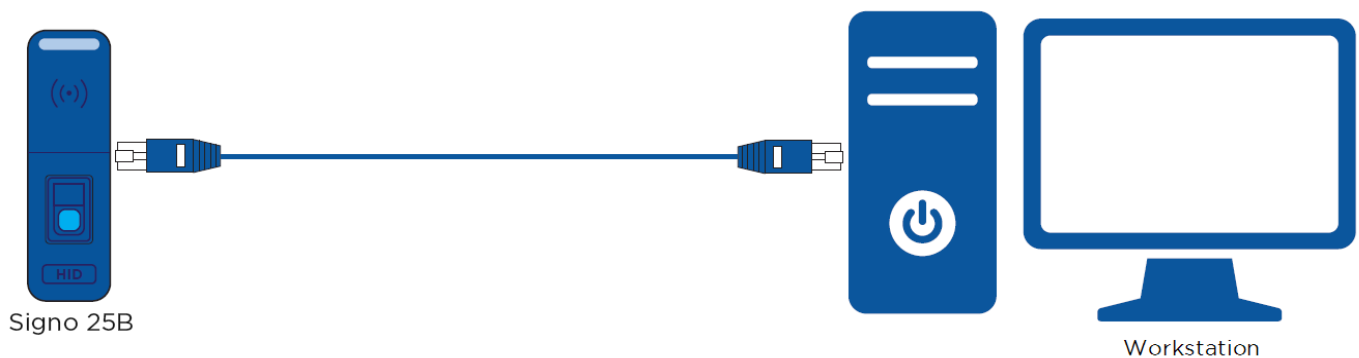

1.4 Hardware reset the Signo 25B

Resetting the Signo 25B device to factory defaults should, where possible, be carried out through the HID Biometric Manager application. Refer to the *HID Biometric Manager Administration Guide* (PLT-04029). In the event that communication between HID Biometric Manager and the Signo 25B is not possible, carry out the following hardware reset at the reader:

1. Unscrew the installation locking screw from the bottom of the Signo 25B mounting bracket.
2. Slide the Signo 25B upwards and remove from the mounting bracket.
3. From the back of the reader, remove the label that covers the contacts.

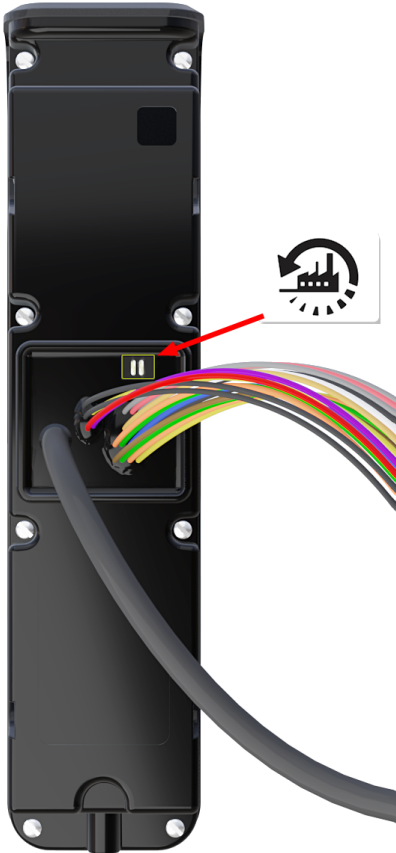

4. With power supplied to the reader, short the contacts together using a suitable metal object.
5. Maintain the short for a full five seconds. The Signo 25B will beep while you hold the short.
6. One long beep of two seconds confirms the reset. All device settings will be returned to the default. You will need to install and update the device in order to return it to the former working level.

Section **02**

Fingerprint enrollment guidelines

The HID® Signo™ Biometric Reader 25B is capable of extracting quality features even from fingers with poor conditions. Nevertheless, correct placement of fingers on the sensor during enrollment helps consistency in fingerprint recognition. Adhere to the following general guidelines and Signo 25B specific guidelines to enroll optimal fingerprint images from a user's finger to improve recognition performance.

2.1 General guidelines

Choose the ideal fingers to enroll

For correct positioning of finger on the sensor, it is recommended to use index or middle fingers.

Correct positioning of finger on sensor

- **Maximum contact area:** Place your finger to completely cover the sensor with maximum contact surface.
- **Place on the center:** Position center of fingerprint (core) on the center of the sensor.
- **Hold your finger still:** Once you place your finger on the sensor, hold finger still until prompted to remove finger.

Note: The positioning of the finger on the sensor is important. If the finger does not cover the maximum contact area, or if the finger is not held still the enrollment will not be successful. For this reason, this product is not recommended for use with children under the age of 12.

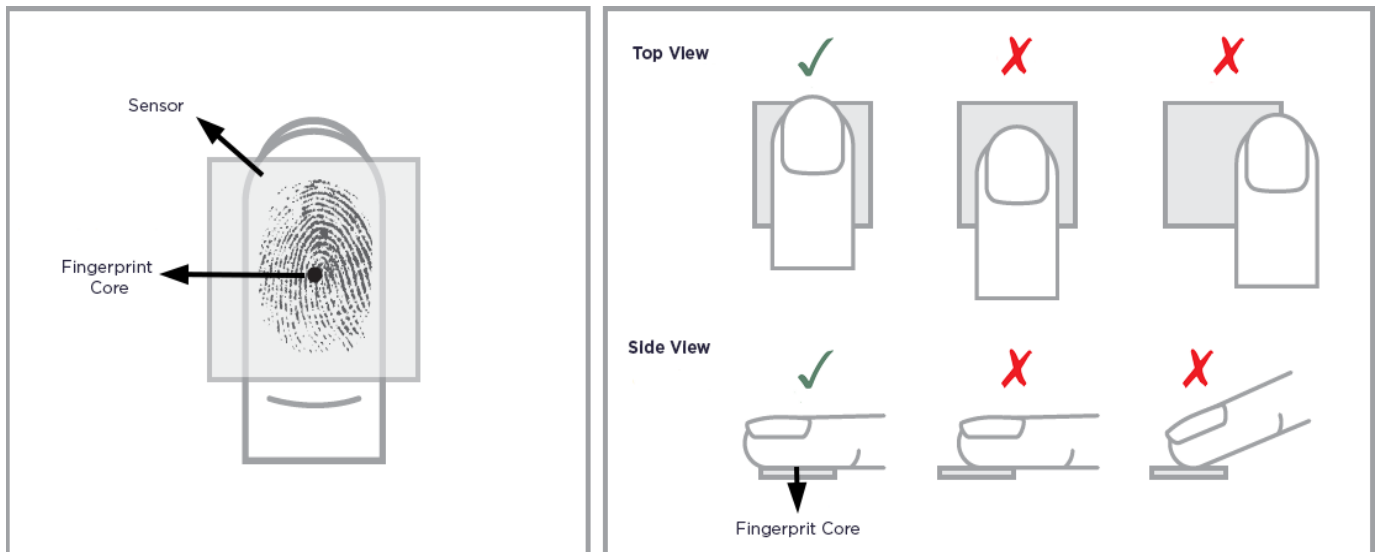

Sensor cleaning

The fingerprint sensor can become soiled by user’s fingers, dust, or other sources. This contamination may affect image quality, degrading authentication performance. It is therefore recommended that you periodically clean the Signo 25B sensor.

In order to avoid scratching the sensor surface use soft lint-free material (or a cotton swab), with gently movements to clean the capture area.

Note: Optical cleaning products that are used for glasses or cell phone glass surfaces can be used to clean the sensor area.

Caution: Do not use acidic liquids or abrasive materials to clean the sensor.

Disinfecting the sensor

To disinfect the sensor, use Ethanol or Isopropanol in a concentration of up to 70% on a soft, lint-free cloth or a cotton swab and gently wipe the capture area.

If a haze is left on the fingerprint sensor, gently dab the area with a soft cloth, dampened with a mild ammonia-based glass cleaner. Do **NOT** wipe the area.

Caution: Do not pour cleaning fluid directly on the fingerprint capture area.

Caution: Do not submerge the sensor in liquid.

Caution: Do not rub the fingerprint capture area with any abrasive material, including paper.

Note: To minimize the spread of germs, it is recommended to wash or sanitize your hands before and after using the fingerprint reader.

Common reasons for enrollment failure

Problem	Solution
Finger is too dry or dirty	Rub the finger in the palm of your hand to moisten/clean it
Finger applied too lightly	Place finger firmly and flat onto the sensor surface
Finger positioned incorrectly	Your finger must cover most of the sensor window
Finger removed or moved during the scan process	Hold your finger still and do not slide it on the sensor window until the scanning process is complete
Injury or wear has changed the fingerprint pattern	Contact the administrator as you may need to enroll another finger

2.2 Fingerprint enrollment best practices for Signo 25B

1. Insert your finger into the Signo 25B sensor area so the finger tip touches the back wall and rests softly on the sensor slope.

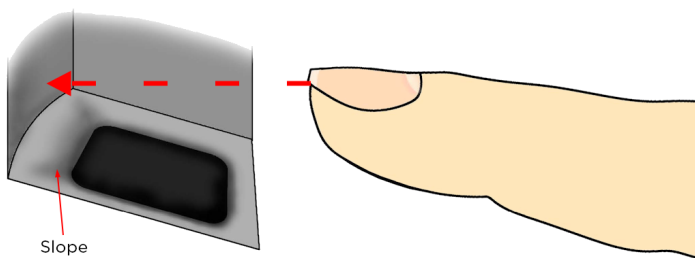

2. Slide your finger down so that it completely covers the sensor window contact surface.

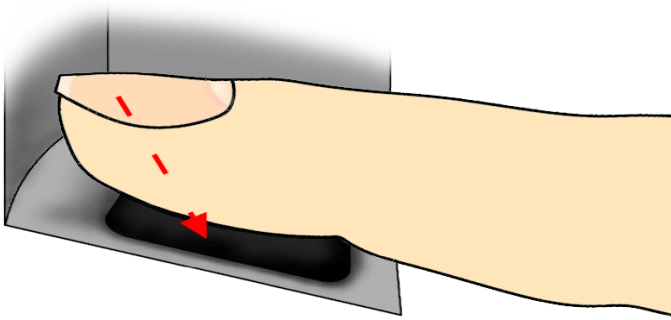

3. Apply gentle pressure on the sensor to slightly flatten your finger and expose a maximum usable area.
4. Keep your finger still until prompted to remove finger.

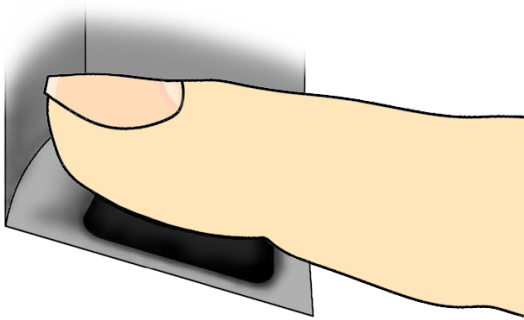

Section **03**

Acronyms and terminology

Term	Definition
Authentication Mode (Signo 25B)	<p>Template on Card: The Signo 25B is waiting for a Credential (Card) to be presented. It retrieves all the biometric templates from the credential. If the presented finger matches the biometric templates retrieved from the credential a Grant Access is recommended. This is a 1:1 Verification match against Template on Card (TOC). The sensor is not armed (blue light off) until the Credential is presented.</p> <p>Card + Finger: The Signo 25B is waiting for a Credential (Card) to be presented. It looks up the user ID and all associated biometric templates in its local device database. If the presented finger matches the biometric templates retrieved from the local database a Grant Access is recommended. This is a 1:1 Verification match against Template on Device (ToD). The sensor is not armed (blue light off) until the Credential is presented.</p> <p>Finger Only: The Signo 25B is waiting for a finger to be presented that is stored in its local device database. If the presented finger matches one stored in the database a Grant Access is recommended. This is a 1:N Identification match against Template on Device (ToD). The sensor is always armed (blue light on).</p> <p>Card Only: The Signo 25B is waiting for a Credential (Card) to be presented. It reads the PACS data only and always recommends a Grant Access. The sensor is never armed (blue light off).</p> <p>Card Only (or) Finger Only: The Signo 25B is waiting for either a Credential (Card) to be presented or a finger, stored in its local device database, to be presented. This authentication mode is particularly useful during initial enrollment setup.</p>
Biometric spoofing	Biometric spoofing is a method of fooling a biometric identification management system. An artificial object (for example, a fingerprint mold made of silicon) is presented to the biometric scanner that imitates the unique biological properties of a person which the system is designed to measure.
BLE	Bluetooth Low Energy (formerly marketed as Bluetooth Smart) is a wireless personal area network technology.
ERR	The Equal Error Rate (EER) is the common value indicating that the proportion of false acceptances (FAR) is equal to the proportion of false rejections (FRR). The lower the EER value, the higher the accuracy of the biometric system.
False Accept Rate (FAR)	The False Accept Rate (FAR) is the measure of the likelihood that the biometric security system will incorrectly accept an access attempt by an unauthorized user.
False Reject Rate (FRR)	The False Reject Rate (FRR) is the instance of a security system failing to verify or identify an authorized person.
FTA	Failure To Acquire. The biometric system failure to extract usable identification data from a biometric sample.
Identification (of Identity)	Typically finding a matching template in a large database of templates. 1:N matching.
LFD	Live Finger Detection. This is used in some markets instead of Spoof. It is also used to refer to insuring a severed finger is not being presented at the sensor.

Term	Definition
MINEX	Minutia Interoperability Exchange. The MINEX program is dedicated to the evaluation and development of the capabilities of fingerprint minutia matchers running on ISO/IEC 7816 smart cards.
M-Series	Mercury Platform Series of Products.
MSI	Multi-Spectral Imaging.
OSDP	Open Supervised Device Protocol (OSDP) is an access control communications standard developed by the Security Industry Association (SIA) to improve interoperability among access control and security products.
PAD	Pressure Attack Detection.
PD	Presence Detection.
ROC	Receiver Operating Characteristic.
SDK	Software Development Kit.
SIA	Structure Image Acquisition.
Tap	The Tap gesture with a mobile device for door opening. The Tap operation is typically used when the mobile device is in close proximity to the reader. Approximately 12 inches (30 cm).
Twist and Go	The Twist gesture with mobile device for door opening. The Twist operation is typically used when the mobile device is at a longer distance from the reader. Approximately 6 feet (2 meters).
TOC	Template on Card. The PACS data is read from the card.
ToD	Template on Device. The PACS data is read from the device database.
vCOM	V-Series Command Protocol.
Verification (of Identity)	Typically a fingerprint template is stored on a card and checked against a finger presented to the finger print sensor. 1:1 matching.

Revision history

Date	Description	Revision
March 2021	Product rebrand from iCLASS SE® Signo 25B to HID Signo® Biometric Reader 25B	B.1
June 2020	Initial release.	A.0



Powering Trusted Identities

Americas & Corporate
611 Center Ridge Drive
Austin, TX 78758
USA

Support: +1 866-607-7339

Asia Pacific
19/F 625 King's Road
North Point
Island East
Hong Kong

Support: +852-3160-9833

Europe, Middle East & Africa
3 Cae Gwyrdd
Green Meadow Springs
Cardiff, CF15 7AB
United Kingdom

Support: +44 (0) 1440 711 822

Brazil
Condomínio Business Center
Av. Ermanno Marchetti, 1435
Galpão A2 - CEP 05038-001
Lapa - São Paulo / SP, Brazil
Phone: +55 11 5514-7100

PLT-04900, B.1