

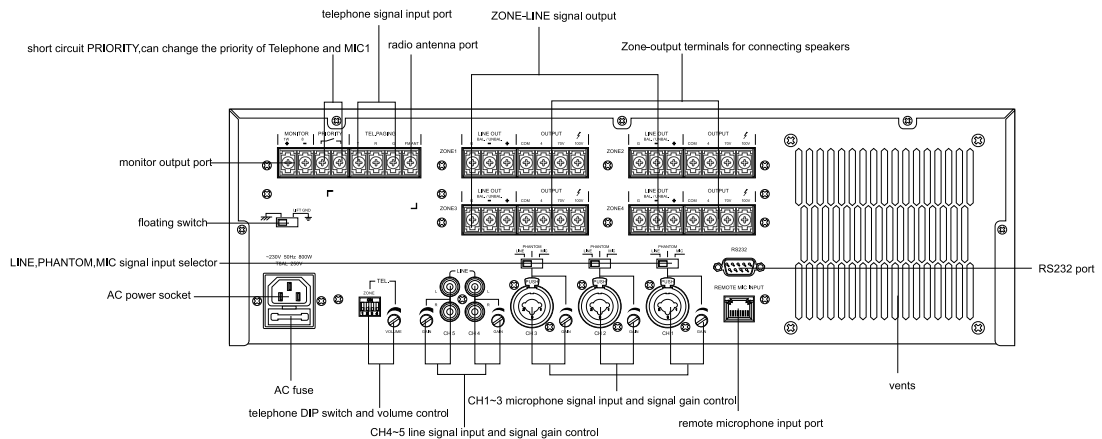

Apariencia



especificaciones

Power Output	4x240W
Speaker Output	70V, 100V & 4Ω
Monitor Output	1W /8Ω
Input Sensitivity & Impedance	CH1, 2, 3: ±2.5mV/600Ω~175mV/10KΩ, (Balanced) CH5-6: 350mV/10KΩ, (Balanced) TEL: 350mV/10KΩ REMOTE MIC±387mV/10KΩ
Tone Control	Bass: ±10dB at 100Hz Treble:±10dB at 10KHz
S/N Ratio	≥65dB
LINE1-4 Output	1V/ 600Ω (Balanced)
Frequency Response	80Hz-16KHz (0/-3dB)
MP3	Support MP3 format, max capacity of 32GB
SD Input	FAT16 & FAT32, support disk one zone, do not support folder, Supports up to 2G-1 bytes as the file size The maximum number of playable files is 65534 Sorts and plays up to 100 files in the order of UNICODE
Mp3 Format	Supports MPEG audio 1, 2 and 2.5. Supports Layer 1, 2and3 Supports sample rates 8K, 16K, 32K, 11.025K,22.05K, 44.1K, 12K, 24K and 48KHz Supports bit rate 8 to 320 kbps and VBR (Variable Bit Rate).Except free format
THD	≤1%
Power Consumption	1200W
Power Supply	~110V -230V 50/60Hz
Dimension	484 x 399 x 132mm
Weight	18kg

Descripción

The 4 channel mixer amplifier range is design with three power outputs: 4x60W and 4x120W 4x240W. The inputs and outputs can be matrix selected, thus it is a high integrated 4 channel audio matrix system solution with Mp3 player for hotel, shopping mall, sports center, entertainment center, etc.Each inputs could be easily designed to different four zones by front panel selector, moreover each input is supplied with separate bass, treble and volume control for precise sound effect for each area.

Three Combo Mic/Line inputs with selector and phantom power, thus the microphone input support both phone jack and XLR type. Two RCA type line inputs, built-in Mp3 player on front panel, one tel input and one RJ45 port for a remote paging microphone T-4012. A RS232 serial communication port is supplied for third party system communication.

A priority input could be used to override all other inputs.A monitor is also built-in for monitoring use. 4 channel separate line inputs and speaker outputs are provided for easy wiring. 70V, 100V and 4Ω speaker outputs all are supplied for versatile sound loudspeaker matching. Extensive protection functions from thermal, short-circuit, clip and overload.

Características

- * Four channel amplifier in a 3U 19"rack mount design.
- * All source inputs could be matrix assigned to different 4 zones outputs simultaneously.
- * The 5 channel inputs & Mp3 input are designed with separate bass, treble and volume control.
- * Three microphone/line inputs with phantom power and gain control.
- * Two aux inputs by RAC with gain control.
- * Mp3 player with SD and USB inputs, separate power supplied module.
- * Built in Tuner audio source.
- * One 4 zone remote microphone input by RJ45 port.
- * Four channel line inputs and speaker outputs.
- * Versatile speaker outputs for each four channels: 70V, 100V and 4Ω.
- * A RS232 serial control port for third party system communication.
- * A priority input to override other inputs (equal to EMC input).
- * Input priority level from high to low: Before short circuit priority input : MIC 1>TEL>Remote.
MIC>MIC2= MIC3=LINE4=LINE5=MP3 After short circuit priority input : TEL>MIC 1>Remote.
MIC>MIC2= MIC3=LINE4=LINE5=MP3 Built-in monitor with volume control.
- * Extensive protection of thermal, short-circuit, clip and overload with indicators.
- * With ground lift switch.