



Monofacial

Bifacial

LP182*199-M-66-NH N-Type TOPCon

Rated Power 560-580W

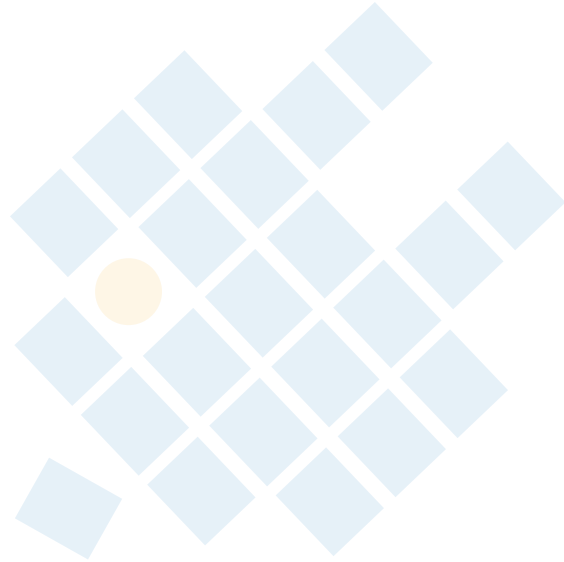

N-Type MBB Cell
New circuit design N-type cells, can increase the output power of 10W~20W



Low Light Features
Higher performance under low light environment.



Higher Output Power
Module adopts 182*199mm half cells, the maximum power can reach 580W.



Load Capacity
Mechanical load tests including wind load 2400 Pa and snow load 5400 Pa done by TUV Nord.

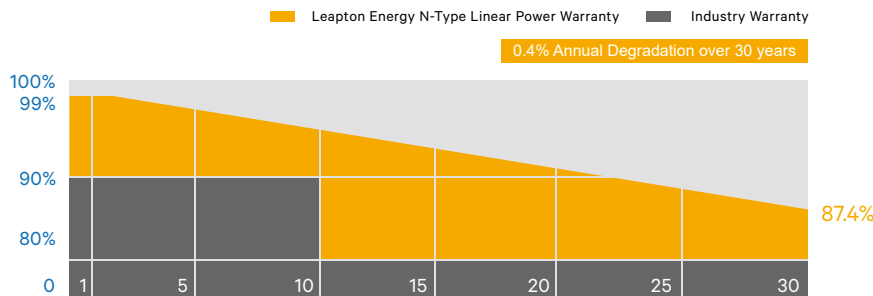

Headquarter : Lepton Energy Co., Ltd.

Tosei Bldg. 6F, 1-2-1 Aioi-cho, Chuo-ku Kobe-shi, Hyogo, 650-0025, Japan

+81-78-382-3182

www.leptonenergy.jp

Manufacturer : Lepton Solar (Changshu) Co., Ltd.

No.9, Sunshine Avenue, Changshu City, Jiangsu, China

+86-512-88800068

info@leptonenergy.com

www.leptonpv.com

MECHANICAL DIAGRAMS

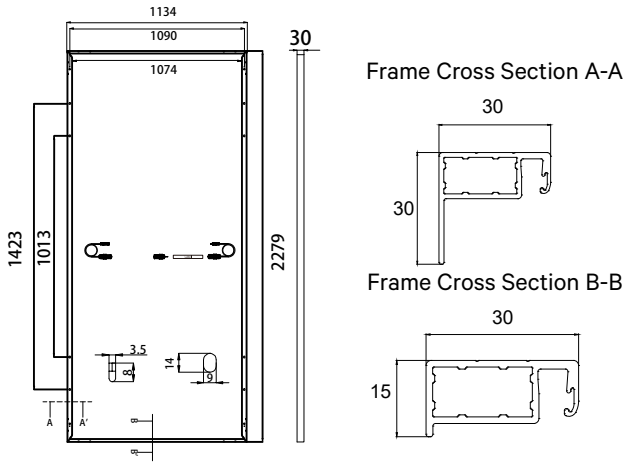

SPECIFICATIONS

Weight	27kg
Dimensions	2279mm*1134mm*30mm
Cell Dimensions	182*199mm
Cell Amount	66*2 pcs
Maximum System Voltage	1500V
Junction Box	IP68
Front glass	3.2mm, Anti-Reflection Coating, High Transmission, Low Iron, Tempered Glass
Frame	Aluminum Alloy
Cable	4mm ² , N 1400mm/P 1400mm for Horizontal installation 4mm ² , N 300mm/P 300mm for Vertical installation
Connector	MC4 compatible

ELECTRICAL PARAMETERS AT STC

Power	560W	565W	570W	575W	580W
Open Circuit Voltage	47.42V	47.62V	47.82V	48.02V	48.22V
Short Circuit Current	15.00A	15.07A	15.12A	15.17A	15.22A
Maximum Power Voltage	39.51V	39.71V	39.91V	40.11V	40.31V
Maximum Power Current	14.17A	14.23A	14.28A	14.34A	14.39A
Module Efficiency	21.67%	21.86%	22.06%	22.25%	22.44%

* Under Standard Test Conditions (STC) of irradiance of 1000 W/m², spectrum AM 1.5 and cell temperature of 25°C.

ELECTRICAL PARAMETERS AT NMOT

Power	421W	471W	429W	433W	437W
Open Circuit Voltage	45.04V	45.24V	45.44V	45.64V	45.84V
Short Circuit Current	12.01A	12.07A	12.13A	12.19A	12.23A
Maximum Power Voltage	36.84V	37.04V	34.24V	37.44V	37.64V
Maximum Power Current	11.43A	11.48A	11.52A	11.57A	11.61A

* Under Nominal Module Operating Temperature (NMOT), irradiance of 800 W/m², spectrum AM 1.5, ambient temperature 20°C, wind speed 1 m/s.

TEMPERATURE CHARACTERISTICS

NMOT	41±3°C	Temp Coefficient of ISC	+0.046%/°C
Temp Coefficient of VOC	-0.25%/°C	Temp Coefficient of Pmax	-0.30%/°C

PACKING CONFIGURATION

Modules/Pallet	36 Pieces	Modules/40'Container	720 Pieces
Packing Description	20 Pallets, Total=(36+36)x10=720 Pieces		

CHARACTERISTICS

LP182*199-M-66-NH 580W

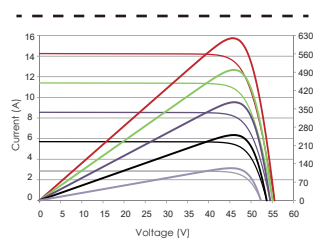

LP182*199-M-66-NH 580W

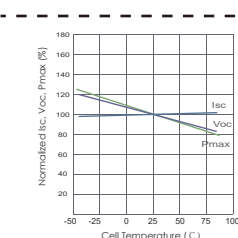

MAXIMUM RATING

Output Tolerance	0~+5W
Operating Temperature	-40°C~+85°C
Wind Load/Snow Load	2400pa/5400pa
Fuse Current	25A



Headquarter : Leapton Energy Co., Ltd.

Tosei Bldg. 6F, 1-2-1 Aioi-cho, Chuo-ku Kobe-shi, Hyogo, 650-0025, Japan

+81-78-382-3182

www.leaptonenergy.jp

Manufacturer : Leapton Solar (Changshu) Co., Ltd.

No.9, Sunshine Avenue, Changshu City, Jiangsu, China

+86-512-88800068

info@leaptonenergy.com

www.leaptonpv.com