

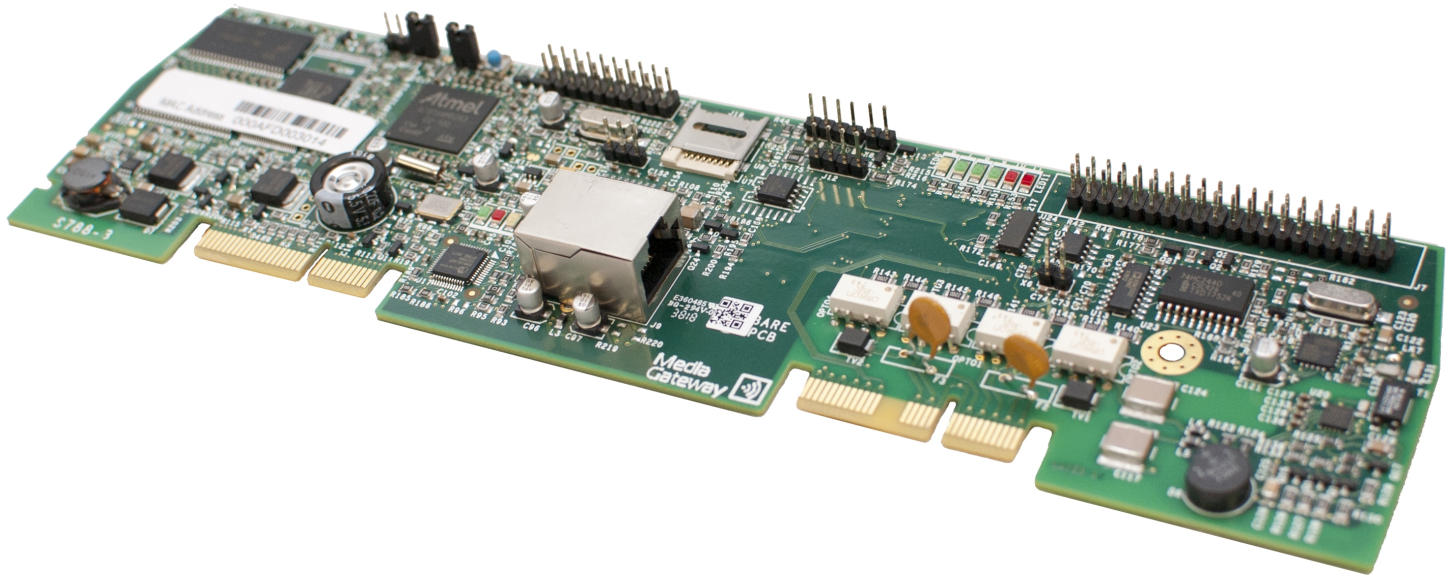

# Media Gateway Panel Module (S788) Information Guide



---

# CONTENTS

---

<b>Contents</b> .....	<b>2</b>
<b>Compliance</b> .....	<b>4</b>
Underwriters Laboratories (UL) .....	4
FCC .....	4
Installation .....	4
<b>Introduction</b> .....	<b>5</b>
Technical Support .....	5
Return Material Authorization (RMA) .....	5
Warranty Service .....	6
Advanced Replacements .....	6
<b>Overview</b> .....	<b>7</b>
<b>Installation</b> .....	<b>8</b>
Before You Begin .....	9
Setting the Address .....	9
Panel Module Placement .....	9
Wiring Overview .....	12
Connecting Communications .....	12
Phone Line Wiring .....	13
Ethernet Cable Routing .....	14
Testing the Installation .....	15
For Off-Premises Signalling .....	15
<b>Configuration</b> .....	<b>16</b>
UL Compliance Limitations .....	19

---

<b>Specifications</b> .....	<b>20</b>
Electrical .....	20
Operating Environment .....	20
Physical Specifications .....	20
Compatible Receivers .....	20
<b>Reporting Format Examples</b> .....	<b>21</b>
Alternating Phone Lines .....	21
<b>Index</b> .....	<b>22</b>

# COMPLIANCE

## Underwriters Laboratories (UL)

---

Fire Alarm Subassembly  
Hochiki America Corporation

## FCC

---

This equipment has been tested and found to comply with the limits for a Class A digital device, pursuant to Part 15 of the FCC Rules. These limits are designed to provide reasonable protection against harmful interference when the equipment is operated in a commercial environment. This equipment generates, uses, and can radiate radio frequency energy and, if not installed and used in accordance with the Installation Manual, may cause harmful interference to radio communications. Operation of this equipment in a residential area is likely to cause harmful interference in which case the user will be required to correct the interference at his own expense. Any changes or modifications not expressly approved by Hochiki America Corporation could void the user's authority to operate this equipment under the rules and regulations of the FCC.

Operation is subject to the following two conditions:

- (1) This device may not cause harmful interference, and
- (2) This device must accept any interference received, including interference that may cause undesired operation.

## Installation

---

Install this product in accordance with NFPA 13, NFPA 72, NFPA 70, and NEC 70 and all local codes.

All field wiring should be installed using fire rated cables according to the NFPA 72. Riser conductors shall be installed in accordance with the survivability from attack by fire requirements in National Fire Alarm Code, NFPA 72, Section 12.3. Riser conductors shall employ either a 2 hour rated cable system, or meet requirements approved by the AHJ.

# INTRODUCTION

## Technical Support

---

For technical support, contact Hochiki America at 800.845.6692 or [technicalsupport@hochiki.com](mailto:technicalsupport@hochiki.com). Hochiki technical support is available Monday through Friday, 7:00AM to 5:00PM, PST.

Prior to contacting technical support, have the following information available:

- Product part number
- Purchase order or order number
- Product serial number
- Current function of the product
- Expected function of the product
- Installation of the product

## Return Material Authorization (RMA)

---

Contact Technical Support to obtain an RMA for any product to be returned. Returns will not be accepted without an accompanying RMA number. An RMA number is assigned when:

- Tech Support acknowledges a possible product failure.
- A product was damaged during shipping
- An incorrect product was shipped
- An order was placed using an incorrect part number \*
- An order was placed using an incorrect part quantity \*
- An order is no longer required \*

\* Restocking fees may apply.

All returned products are tested to confirm operating failures experienced in the field. If the product is found to be functional, contractors must absorb expenses for return shipping, as well as the cost and shipping of the advanced replacement product.

Prominently display the RMA number on all packages sent for return.

Ship all return products to:

Attention: RMA # \_\_\_\_\_  
Hochiki America  
7051 Village Park Drive, Suite 100  
Buena Park, CA 90621

## **Warranty Service**

---

Technical Support can replace or repair a defective product when the original purchase is within the warranty period defined in the sales contract. Check your contract for more information, or contact your sales representative about your specific warranty period.

### **Advanced Replacements**

Products that fail to operate in the field can be replaced quickly using the advanced replacement process. The advanced replacement process is available to all contractors who maintain an acceptable line of credit.

Initiate the advanced replacement process by requesting an RMA number from a Tech Support representative. Advanced replacements can be shipped to your location when the product is covered under warranty and when a replacement product is in stock.

- Advanced replacements can be expedited at the request of the contractor. Shipping costs associated with this process are the responsibility of the contractor.
- Products returned using the advanced replacement process must be received within 30 days of the RMA issue date.

# OVERVIEW

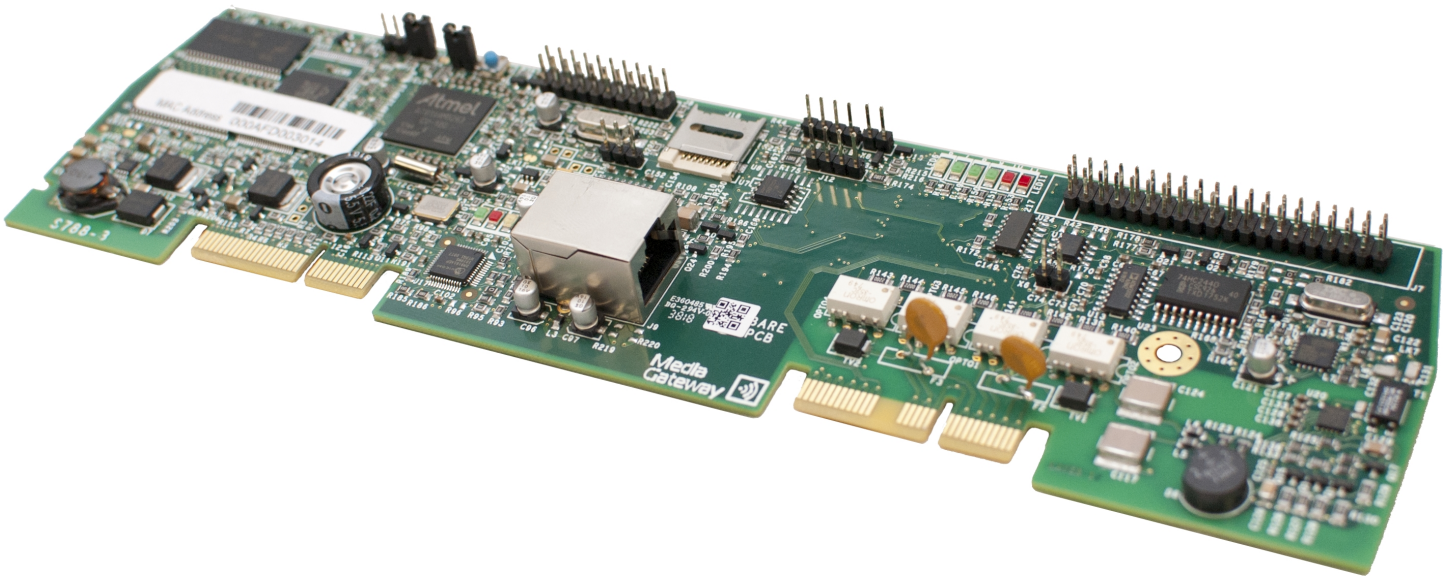

## Media Gateway Panel Module

### S788

The Media Gateway™ is a communication panel module for the FireNET L@titude Fire Alarm Control Panel. It provides connectivity to a remote monitoring center via Sur-Gard Fibro or dial-up. SIA is the recommended format for usage, but Contact ID is also supported. Transmission can be made through one or two telephone lines, and/or IP through Ethernet. Standard reporting codes have been pre-defined, although the user may customize these codes through the Loop Explorer 2 programming application.

# INSTALLATION

This section provides instructions for connecting cables, mounting, and testing the Media Gateway Panel Module for installation. There can only be one Media Gateway per network.

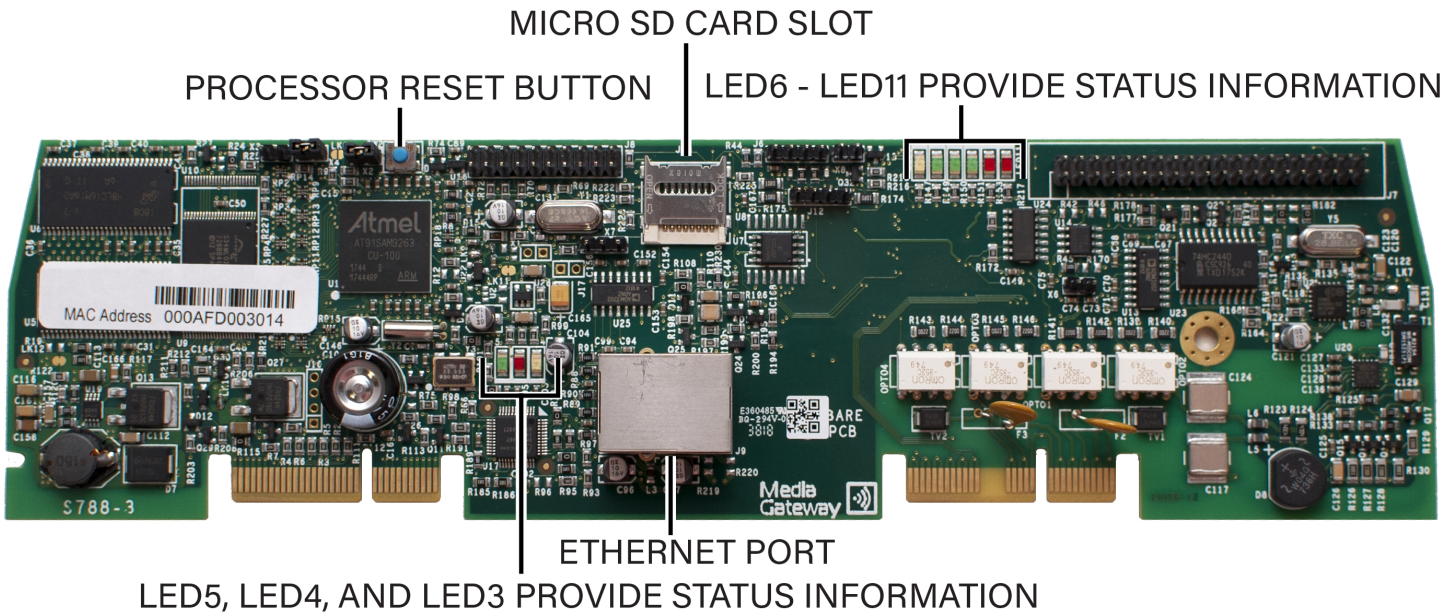

- Notify the monitoring center and location security that the FireNET L@titude Fire Alarm Control Panel will be temporarily out of service.
- Remove the module from its packaging and check its contents.
- Make phone line connections (if used) as shown in [Connecting Communications](#).
- Remove AC and battery power from the panel.
- Install the module into slot F on the Main Back Board.
- Insert the Ethernet cable (if used) to the jack on the Media Gateway Panel Module.
- Restore AC and battery power.
- Wait for the panel start-up process to complete. Refer to the **FireNET L@titude Fire Alarm Control Panel Installation Manual (MAN-1431HA)** for more information.
- [Configure](#) the module using Loop Explorer 2 or the panel GUI.
- Test communication from the panel via the [LED Status Indicators](#).

Install this product in accordance with NFPA 72, the National Electrical Code, and all local codes.

---

**WARNING!** The module must be installed by personnel familiar with electronic components. Electronic components within the module are vulnerable to damage from electrostatic discharge. Ground straps must be worn by installers before handling to prevent electrostatic discharge damage.

---

## Before You Begin

---

Before you begin the installation, take a few minutes to review the installation information, gather the required items, and complete the tasks listed below to make the installation as quick and easy as possible. Acquire the following items that are not included with the Media Gateway Panel Module, but may be required for installation:

- **Ground Strap** - A ground strap is required for handling circuit boards. The ground strap is not provided in the packaging of the Media Gateway Panel Module.

## Setting the Address

---

The Media Gateway Panel Module is addressed internally and will not conflict with other installed, addressable modules.

## Panel Module Placement

---

The Media Gateway Panel Module must be installed into Slot F.

To install modules on the FireNET L@titude Fire Alarm Control Panel:

1. Disconnect AC power and standby batteries prior to performing the module installation.
2. Remove the retaining screw and plastic cover.



3. Remove the panel module from the protective packaging using adequate electrostatic protection.
4. Point the conductor side of the panel module toward the backplate.
5. Insert the notched end of the panel module in the metal guide notch of the backplate at an angle, as shown.

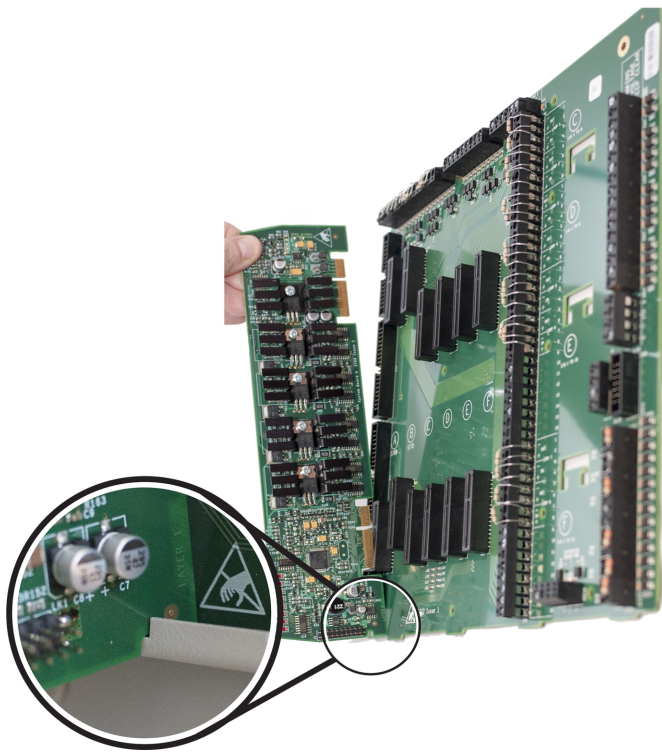

The photo above is an example of panel module placement and may not be representative of the specific module and slot placement described in this guide. Refer to the checklist above for details on placement.

6. Rotate the panel module until all conductors are securely inserted into connectors of the Main Back Board.
7. Replace the cover onto the Main Back Board.
8. Reconnect the batteries and restore AC power.

# Wiring Overview

## Connecting Communications

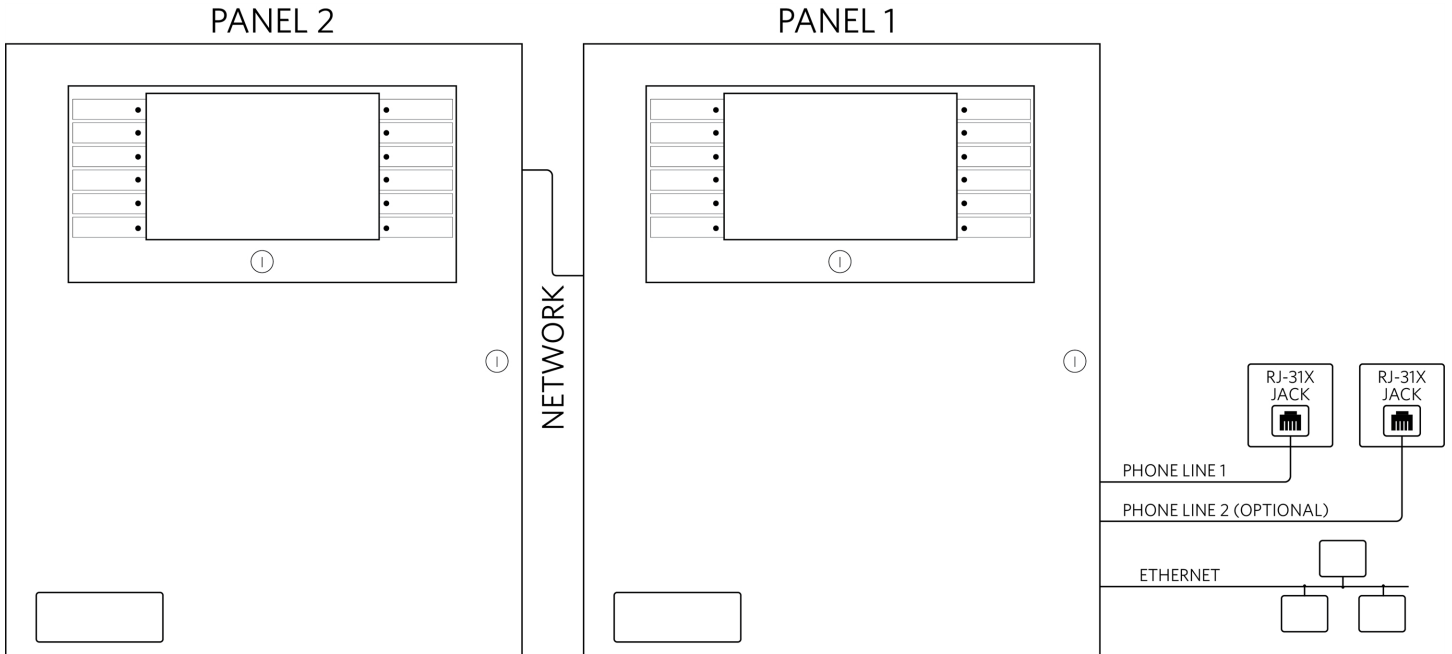

## Phone Line Wiring

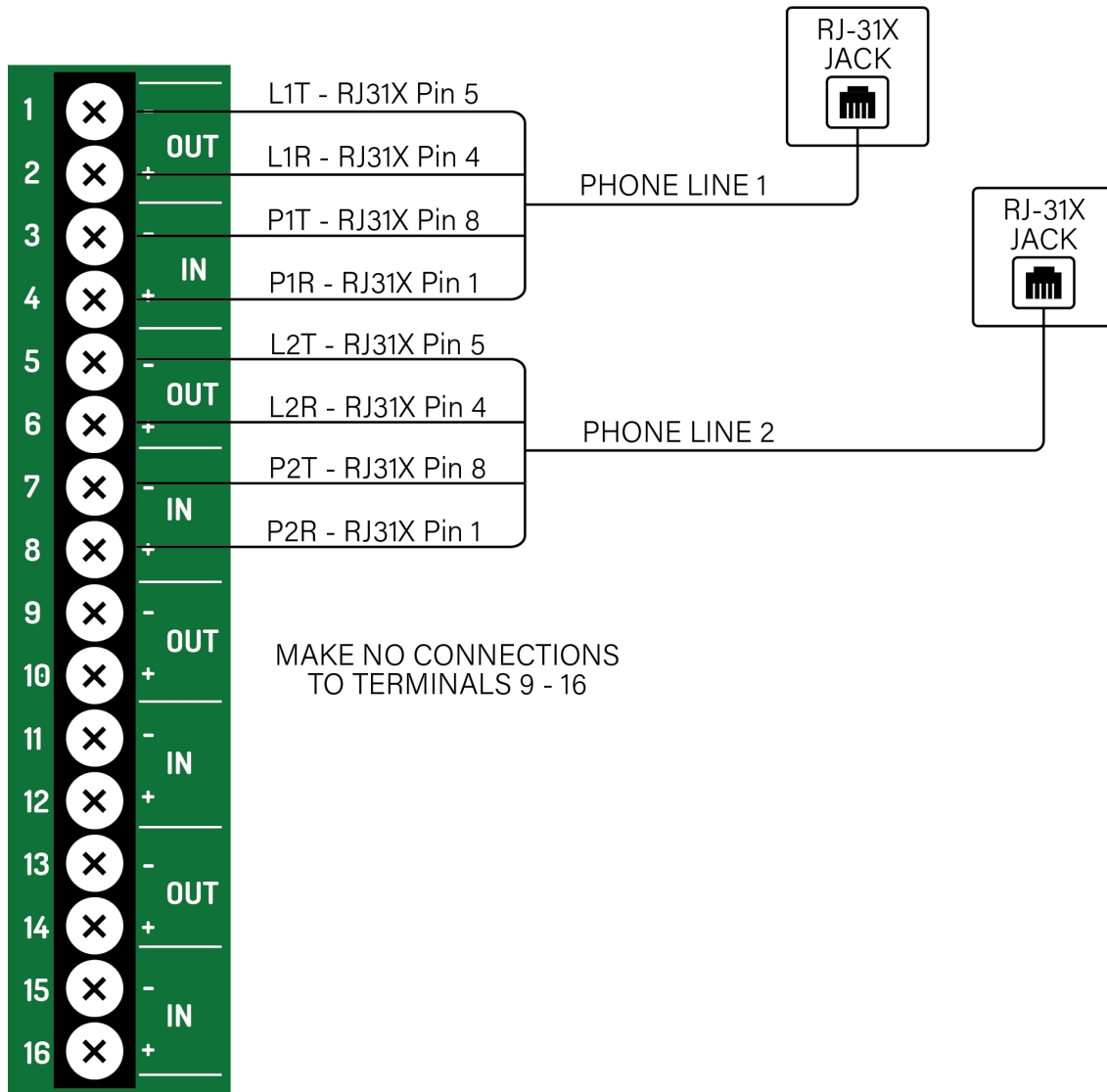

The phone line(s) entering the cabinet must either be separate from all other wiring in the enclosure with a minimum distance of 0.25" or be contained within insulated tubing. The minimum telecommunications wire gauge is 22 AWG.

## Ethernet Cable Routing

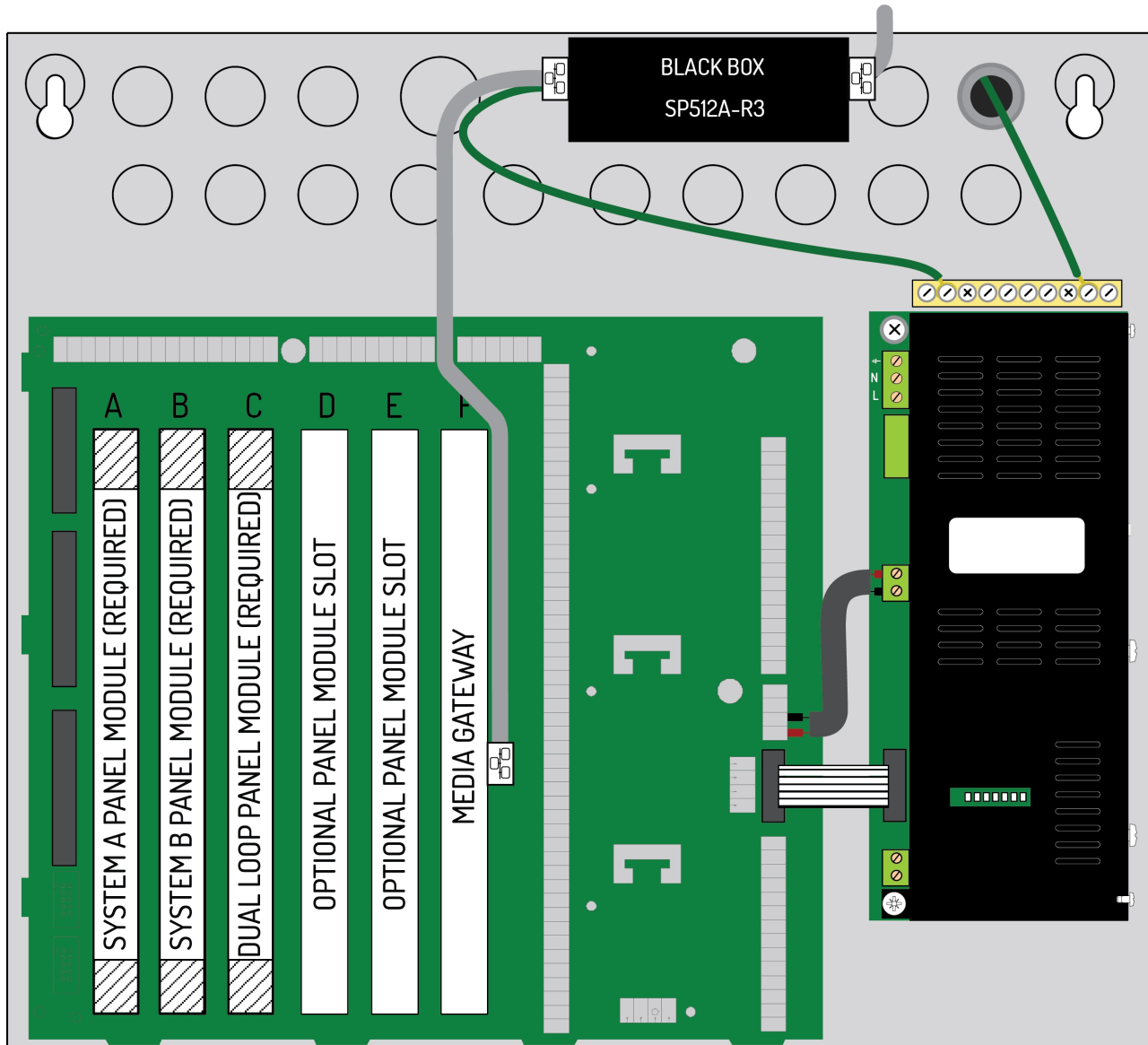

The ethernet cable entering the cabinet must be separate from all other wiring in the enclosure with a minimum distance of 0.25". Phone line connections require surge protection. Install a CAT5e Surge Protector (Black Box SP512A-R3) when wiring the Media Gateway Panel Module as shown.

To accommodate the plastic cover, route ethernet cabling through the space between the screw terminals as shown above.

## Testing the Installation

---

Confirm communication from the panel via the LED status indicators. LED indicators provide functional and diagnostic information as shown below.

LED Indicator	Color	Description
LED3	Yellow	Ethernet - Full Duplex
LED4	Red	Ethernet 100Mbps Speed
LED5	Green	Ethernet Link & Activity
LED6	Yellow	Flashing identifies an error.
LED7	Green	COMM3 - Flickers to indicate processor activity.
LED8	Green	COMM2 - Flashes when Phone Line 2 is in use.
LED9	Green	COMM1 - Flashes when Phone Line 1 is in use.
LED10	Red	Activates when a Sur-Gard FIBRO message is sent.
LED11	Red	Heartbeat - Identifies functional status of the panel module.

### For Off-Premises Signalling

---

After configuring the panel module (refer to [Configuration](#) for more information), send a test signal using each transmission path (with all other paths disconnected during each test) to the monitoring station to confirm proper operation of each path.

For example, when testing Phone Line 1, disconnect Phone Line 2 and Ethernet. Repeat the test for each path.

# CONFIGURATION

The Media Gateway Panel Module can be configured via LE2 or the Panel GUI.

## Configure Media Gateway Settings

Dialer Accounts LAN Virtual Resource MCE Advanced Configuration

**Phone Numbers**

Site Number

MAC Address

**Line Type**

Tone  Pulse  Both

**Line Monitoring**

Line 1  Line 2

**AC Power Fail Report**

Delay minutes

**Number of Rings**

Save Cancel

Media Gateway Configuration via LE2



Media Gateway Configuration via the Panel GUI

1. Select a **Line Type**. This is the method used by the Media Gateway to dial. Options are Tone, Pulse, or Both.

Tone is the preferred in most installations. However, depending on your location, Tone may not be supported. When Both is selected, the Media Gateway first attempts Tone dialing. If that fails, Pulse will be attempted. Both can be selected during troubleshooting, but is not recommended for the final installation.

2. Select the line(s) that should be monitored. Phone line monitoring is optional since the phone lines may not be connected. At least one phone line is required to be connected to meet the requirements of Section 41.2.3 of UL 864 10th Edition.

All phone lines that are in use must be monitored. Phone lines that are not monitored will not be used.

3. Set a time delay before the Media Gateway reports an AC Power Failure. Valid values are 0 - 180 minutes. The delay must be set to between 60 - 180 minutes to meet the requirements of Section 55.2.1 of UL 864 10th Ed.
4. Set the time for a test signal to be sent. The **Time** field is for the time of day in 24-hour format.
5. Set the **Frequency** interval of the test signal . Valid options are 6, 12, 18, or 24 hours. The **Frequency** must be set to 6 hours to meet the requirements of Section 41.3.2.13 of UL 864 10th Ed.
6. Select whether to report by Point (device) or by Zone. Zone reporting sends the same signal for all points in the zone, therefore the central station will not be able to differentiate between different points in the zone. Point reporting provides more specific location information.

When selecting to report by Point, Contact ID may not report points above 99 or loops in excess of 9 accurately. SIA is the preferred transmission protocol.

7. For each account (1-4),
  - Set the **Account Number** that will be used to identify the particular site to which the Media Gateway sends data. The account number must be between 4-6 digits.
  - Set the **Phone Number(s)** of the receiver (monitoring station). An optional second number may be entered. Each number can be up to 30 digits. If a pause is needed, insert a "," character. To wait for a secondary dial tone, insert a "w" character.
  - Select either Dialer or Sur-Gard FIBRO for the **Transport Medium**. Dialer will use the phone line pathways; Sur-Gard FIBRO will use Ethernet.
  - Select Contact ID or SIA for the **Protocol**. This is the signaling method that will be used to transfer data to the receiver (monitoring station).
  - Choose the panel event types that the Media Gateway will transmit to the receiver. This is user-configurable for any given setup. For example, it enables Account 1 to report alarms to one central station and Account 2 to report trouble signals to another station.

Account 2 can be used as a backup to Account 1 (and Account 4 as a backup to Account 3). To set an account as a backup, select **Backup Reporting** for Account 2 (or 4) and de-select all other event types. When a transmission fails using the primary account, the panel will attempt communication using the backup account. This is commonly used to configure reporting via phone line with ethernet backup to meet the requirements of Section 41.3.2.8 of UL 864 10th Edition.

8. Enter a **DSC IP Address**. This is the IP address of the Sur-Gard FIBRO receiver. This should be obtained from your central station.
9. Enter the **Local Port Number**. This is the local port number of the Sur-Gard FIBRO receiver. This should be obtained from your central station.
10. Enter the **Remote Port Number**. This is the remote port number of the Sur-Gard FIBRO receiver. This should be obtained from your central station.

11. Select whether the connection is **Supervised**. When supervision is enabled, the panel monitors the connection to the central station.
12. Enter the **Advanced Encryption Standard (AES) Key**, up to 32 characters.
13. The following fields are common parameters that are a function of the LAN through which the Media Gateway is connected. Contact your network administrator for appropriate settings.
  - DHCP
  - Fixed IP Address
  - Subnet Mask
  - Default Gateway
14. For reporting code modification, contact technical support.

## UL Compliance Limitations

In order for the product to comply with the requirements in the **Standard for Control Units and Accessories for Fire Alarm Systems, UL 864 10th Edition**, certain programming features or options must be limited to specific values or not used at all as indicated below.

Field	Configurable Range	UL Permitted Value / Range
Line Monitoring	On or Off	At least one phone line is required to be connected to meet the requirements of Section 41.2.3 of UL 864 10th Ed.
AC Power Failure Report	0 - 180 minutes	The delay must be set to between 60 - 180 minutes to meet the requirements of Section 55.2.1 of UL 864 10th Ed.
Frequency	6, 12, 18, or 24 hours	The frequency must be set to 6 hours to meet the requirements of Section 41.3.2.13 of UL 864 10th Ed.
Backup Reporting	On or Off	Backup reporting must be On to configure reporting via phone line with ethernet backup to meet the requirements of Section 41.3.2.8 of UL 864 10th Edition.

# SPECIFICATIONS

This appendix provides electrical and environmental specifications for the Media Gateway Panel Module.

## Electrical

Supply Voltage Range	24 V DC
Maximum Current Consumption	114 mA
Quiescent Current	114 mA

## Operating Environment

Dry indoor use only.

Temperature Range	-5°C - 49°C or 23°F - 120°F
Relative Humidity	Up to 95%, non-condensing

## Physical Specifications

Dimensions	9¼" x 2½" or 234.6mm x 62.8mm
------------	-------------------------------

## Compatible Receivers

- Sur-Gard System III (FIBRO and Dialer)
- Silent Knight Model 9500 Desktop Digital Alarm Receiver (Dialer only)
- Silent Knight Model 9800 Digital Alarm Signal Receiver (Dialer only)

# REPORTING FORMAT EXAMPLES

## Alternating Phone Lines

---

This section details known phone call attempt patterns for the Media Gateway.

### Account 1 - Sur-Gard FIBRO

Account 2 - Modem, Backup, Phone # 1, Phone # 2, Line 1, Line 2

1. Account 2, Phone # 1, Line 1
2. Account 2, Phone # 1, Line 1
3. Account 2, Phone # 2, Line 1
4. Account 2, Phone # 1, Line 2
5. Account 2, Phone # 2, Line 2
6. Account 2, Phone # 1, Line 1
7. Account 2, Phone # 2, Line 1
8. Account 2, Phone # 1, Line 2
9. Account 2, Phone # 2, Line 2

If both account types are Modem

Account 1 - Modem, Phone # 1, Phone # 2, Line 1, Line 2

Account 2 - Modem, Backup, Phone # 1, Phone # 2, Line 1, Line 2

- |                                  |                                  |
|----------------------------------|----------------------------------|
| 1. Account 1, Phone # 1, Line 1  | 1. Account 2, Phone # 1, Line 1  |
| 2. Account 1, Phone # 1, Line 1  | 2. Account 2, Phone # 1, Line 1  |
| 3. Account 1, Phone # 2, Line 1  | 3. Account 2, Phone # 2, Line 1  |
| 4. Account 1, Phone # 1, Line 2  | 4. Account 2, Phone # 1, Line 2  |
| 5. Account 1, Phone # 2, Line 2  | 5. Account 2, Phone # 2, Line 2  |
| 6. Account 1, Phone # 1, Line 1  | 6. Account 2, Phone # 1, Line 1  |
| 7. Account 1, Phone # 2, Line 1  | 7. Account 2, Phone # 2, Line 1  |
| 8. Account 1, Phone # 1, Line 2  | 8. Account 2, Phone # 1, Line 2  |
| 9. Account 1, Phone # 2, Line 2  | 9. Account 2, Phone # 2, Line 2  |
| 10. Account 1, Phone # 1, Line 1 | 10. Account 2, Phone # 1, Line 1 |

# INDEX

---

## B

Black Box 14

## C

Cabling 14

Class A 4

## H

Heartbeat 15

## L

Loop Explorer 2 7-8

## M

Main Back Board 8

## N

Network 8, 19

## S

Slot F 8

Standby Batteries 9

## T

Terminals 14