



FireNET L@titude Fire Alarm Control Panel Installation Manual



CONTENTS

Contents	3
Glossary	13
Compliance Information	15
Underwriters Laboratories (UL)	15
NFPA	15
FM Global Technologies LLC (FM APPROVALS)	15
Introduction	16
Technical Support	16
Return Material Authorization (RMA)	16
Warranty Service	17
Advanced Replacements	17
Installation	18
Preparing for Installation	19
Mounting the FireNET L@titude Fire Alarm Control Panel	21
Removing Cabinet Components	21
Replacing Cabinet Components	24
Connecting and Dressing Cabling	24
Connecting 24V and 14 Conductor Wiring	24
Installing Power Supplies	24
The 5.25 Amp Power Supply	24
The 10.25 Amp Power Supply	26
Connecting Standby Batteries	26
Installing Optional Panel Modules	28

DIP Switch Settings	28
Placement	28
Installing the Network Module	31
Network Connections	31
Fiber Optic Networking	32
Connecting Field Wiring	35
Wiring Diagram	36
Class A SLC Loops	37
Class B SLC Loops	38
Class X SLC Loops	39
Notification Appliances	39
Connecting Notification Appliances	40
Connections for NAC Power Output Modes	41
Continuous Constant Power	41
Door Holder	41
Resettable	42
AUX 24V 1 and AUX 24V 2	42
Relay Contacts	43
Network	44
RS-485 I/O	44
Fire Routing Output 1	45
Prog Input	45
Routing I/O Terminals	46
Installing Addressable Devices	47
SLC Detector Spacing	47

SLC Device Detector Sensitivity	47
Detector Calibration / Drift Compensation	47
Addressing an SLC Module	47
Hochiki Protocol	47
Connecting SLC Devices	47
Hochiki Protocol	48
Installing Municipal Boxes	50
Testing the Installation	51
Panel Start-up	51
Loading Configuration	52
Testing the Power Supply	52
Testing the Field Circuits	52
Testing the Panel GUI	53
Panel Tests	53
Lamp & Buzzer Test	53
Display Test	54
System Information	54
Event Log	54
Programming the Panel	56
Loop Explorer 2	56
Troubleshooting	57
Overview	58
Required Modules for Minimum Operation and Basic Function	59
System A Panel Module (S769)	59
System B Panel Module (S770)	60

Dual Loop Panel Module (S758)	61
Notification Appliances	63
Synchronization	63
Configuring NAC Outputs	64
Optional Modules and Assemblies	65
Network Module (S723)	65
Printer (S768)	66
Zone LED Module (S771)	66
16 Channel I/O Interface Card (S560)	67
Use Case Examples	67
Restrictions	68
16 Channel I/O Panel Module (S772)	68
Use Case Examples	69
Restrictions	69
L@titude Network Vision Annunciator (S787)	70
Media Gateway™ Panel Module (S788)	71
8 Channel Relay Panel Module (S791)	71
Use Case Examples	71
8 Channel Conventional Zone Panel Module (S792)	72
4 Channel NAC Panel Module (S793)	72
Batteries	73
Standby Battery Type	73
Fascia	74
LED Status Indicators	76
Panel LEDs	76

Fire In Zone Indicators	76
Main Back Board (S722)	78
NAC and AUX 24V Terminals	80
Terminals	81
Panel Module Slots	82
Field Terminal Assignments	83
Panel Module Slots	84
Board Slot C	84
Board Slot D	84
Board Slot E	85
Board Slot F	85
Extension Board Power Terminals	86
Network, RS-485 I/O, Fire Routing Output 1, and Prog Input	87
Power Supply Terminals	88
0V Terminals	88
Power Supply Trouble Signaling Connector	89
Supervised Input and Output Terminals	89
Extension Board (S786)	90
Extension Board Features	92
Panel Module Slots and Terminals	93
Board Slot G, H, J, K	93
Slot G	93
Slot H	94
Slot J	95
Slot K	96

Other Terminals	96
LCD Main Processor Board (S721)	97
Connectors and Ports	98
Switches, LED Indicators, and Internal Buzzer	99
19 Inch Rack Mount Enclosure	100
Installation	101
Batteries	102
Connecting Field Wiring	103
Power Supply	105
Power Supplies	106
Features	107
DIP Switches	107
10.25 Amp Power Supply	108
Special Application Mode Table	109
Status Indicators	109
Events and Status	111
Fire	111
CO	112
Trouble	112
Supervisory	112
Disablement	113
Other Events	113
Maintenance and Repair	114
Batteries	115
Replacing Battery Leads	115

Replacing Standby Batteries	115
Removing the Standby Batteries	115
Installing the Standby Batteries	115
Fuses	116
Battery Lead Fuse on 5.25A Power Supply	116
Replacing the Power Supply Fuse	116
Removing the Power Supply Fuse	116
Installing the Replacement Power Supply Fuse	117
Replacing Internal Components	118
Appendix A: Specifications	120
Operating Constraints	121
Electrical	122
AC Input Ratings	122
Power Supply	123
Fuses	123
24 VDC Output Ratings	123
Standby Battery Ratings	123
Ground Trouble Indication	123
System Power	124
Standby and Alarm Current	124
5.25 A Power Supply	124
10.25 A Power Supply	124
Battery	125
Rechargeable Standby Battery Circuit	125
Standby Battery Loads	125

Operating Environment	135
Cabinet Housing	136
4 Slot Standard Enclosure	137
8 Slot Standard Enclosure	138
4 Slot Deep Enclosure	139
8 Slot Deep Enclosure	140
19" Rack Mount	141
Appendix B: Equipment List	144
Panel Model Numbers	145
Replacement Parts	147
Accessories	149
Loop Devices	150
Special Application NAC Outputs	153
Amseco Compatible NAC Devices	153
Gentex Compatible NAC Devices	154
System Sensor Compatible NAC Devices	155
Wheelock Compatible NAC Devices	156
Maximum Line Impedance	163
Compatible Devices for Auxiliary 24V	163
Appendix C: Calculations	164
SLC Loop Cabling	165
Example Voltage Drop Condition	165
Voltage-drop of the twin Conductor Cable	165
Voltage at the load	166
14 AWG Cable	166

16 AWG Cable	168
18 AWG Cable	170
NAC Cabling	173
12 AWG Cable	173
14 AWG Cable	174
16 AWG Cable	176
AUX 24V Cabling	178
12 AWG Cable	179
14 AWG Cable	180
16 AWG Cable	182
Determining the Total Load Current	185
Determining the Standby Battery Capacity	186
Battery Rating Equation	186
Amp Hour Rating	187
Supervising Station Requirements for Combination Systems	189
Index	190

GLOSSARY

SYMBOLS



Indicates a ground terminal

A

AHJ

Authority Having Jurisdiction. The government body, organization, office, or individual having the power to enforce and/or interpret laws, codes, and rules.

Ancillary Device

A device connected to a fire alarm system not required by the fire alarm standard, but may be required by other standards, e.g. door holders, smoke control fans, remote LED indicators, remote alarm, or trouble units.

AWG

American Wire Gauge. The standard American designation of wire sizes. Wire size is an inverse relation to gauge numbers that range from 0000 to 40 AWG. Also called Brown and Sharpe or B&S gauge.

C

Class A

A wiring classification of circuits capable of transmitting an alarm signal during a single open or non-simultaneous ground fault on a conductor.

Class B

A wiring classification of circuits NOT capable of transmitting an alarm signal beyond a single open or during a short between conductors.

Class X

A wiring classification capable of transmitting an alarm signal during a single open, short, or non-simultaneous ground fault on a conductor.

D

DIP Switch

A group of two-position electrical contacts mounted in a Dual Inline Package (DIP), typically used to set address or function information.

E

End-Of-Line Device (EOL)

An electronic component physically installed as the furthest device from the control panel; whose presence on the circuit is used to monitor the integrity of the circuit.

N

NAC

Notification Appliance Circuit. A supervised output circuit that connects horns, strobes, speakers, etc. to the control panel.

S

SLC

Signaling Line Circuit. A Signaling Line Circuit (SLC) carries data to and from the field devices for the fire alarm system, and also carries power from the control panel to the devices.

Supervision

Monitoring the integrity of a circuit or device to detect a fault condition that would prevent normal operation.

COMPLIANCE INFORMATION

Underwriters Laboratories (UL)

Fire Alarm Equipment

Hochiki America Corporation

The FireNET L@titude Fire Alarm Control Panel is suitable as follows:

- Types of signaling services are automatic fire alarm and manual fire alarm
- Class A, B, and/or X Signaling Line Circuits
- Class A and/or B for Notification Appliance Circuits
- Protected Premises Unit (PPU) for Local Service, Remote Station Service, Center Station Service, Proprietary Service, Auxiliary Service.

NFPA

Install this product in accordance with NFPA 72, NFPA 70, and NEC 70 and all local codes.

Install SLC detectors with spacing as specified in section NFPA 72. Units employing "multiple detector operation" shall include guidelines for installing of a minimum of two detectors in each protected space and to reduce the detector installation spacing to 0.7 times the linear spacing in accordance with National Fire Alarm Code, NFPA 72.

All field wiring should be installed using fire rated cables according to the NFPA 72. Riser conductors shall be installed in accordance with the survivability from attack by fire requirements in National Fire Alarm Code, NFPA 72, Section 12.3. Riser conductors shall employ either a 2 hour rated cable system, or meet requirements approved by the AHJ.

FM Global Technologies LLC (FM APPROVALS)

Hochiki America Corporation

INTRODUCTION

Technical Support

For technical support, contact Hochiki America at 800.845.6692 or technicalsupport@hochiki.com. Hochiki technical support is available Monday through Friday, 7:00AM to 5:00PM, PST.

Prior to contacting technical support, have the following information available:

- Product part number
- Purchase order or order number
- Product serial number
- Current function of the product
- Expected function of the product
- Installation of the product

Return Material Authorization (RMA)

Contact Technical Support to obtain an RMA for any product to be returned. Returns will not be accepted without an accompanying RMA number. An RMA number is assigned when:

- Tech Support acknowledges a possible product failure.
- A product was damaged during shipping
- An incorrect product was shipped
- An order was placed using an incorrect part number *
- An order was placed using an incorrect part quantity *
- An order is no longer required *

* Restocking fees may apply.

All returned products are tested to confirm operating failures experienced in the field. If the product is found to be functional, contractors must absorb expenses for return shipping, as well as the cost and shipping of the advanced replacement product.

Prominently display the RMA number on all packages sent for return.

Ship all return products to:

Attention: RMA # _____
Hochiki America

7051 Village Park Drive, Suite 100
Buena Park, CA 90621

Warranty Service

Technical Support can replace or repair a defective product when the original purchase is within the warranty period defined in the sales contract. Check your contract for more information, or contact your sales representative about your specific warranty period.

Advanced Replacements

Products that fail to operate in the field can be replaced quickly using the advanced replacement process. The advanced replacement process is available to all contractors who maintain an acceptable line of credit.

Initiate the advanced replacement process by requesting an RMA number from a Tech Support representative. Advanced replacements can be shipped to your location when the product is covered under warranty and when a replacement product is in stock.

- Advanced replacements can be expedited at the request of the contractor. Shipping costs associated with this process are the responsibility of the contractor.
- Products returned using the advanced replacement process must be received within 30 days of the RMA issue date.

INSTALLATION

This section provides instructions for connecting cables, mounting, and testing the FireNET L@titude Fire Alarm Control Panel for installation. The following is a general checklist for the installation of the panel. Detailed instructions are provided for each step.

WARNING! Disconnect AC and battery power before making any field connections. Double-check all termination points before applying power to the panel! Incorrectly terminated wiring may cause permanent damage to the panel.

IMPORTANT! The FireNET L@titude Fire Alarm Control Panel installation must be performed by qualified service personnel. Maintain extreme care when anchoring the cabinet to the premises wall. Electronic components within the panel are vulnerable to physical damage from severe shock and vibration. Remove the cabinet door and fascia for the installation of the panel. Detailed instructions are provided for each step.

	Task
<input type="checkbox"/>	Obtain required mounting hardware, tools, and batteries.
<input type="checkbox"/>	Disconnect ribbon and ground cables.
<input type="checkbox"/>	Open and remove the fascia from the cabinet.
<input type="checkbox"/>	Open and remove the door from the cabinet.
<input type="checkbox"/>	Remove the backplate and any installed batteries from the cabinet.
<input type="checkbox"/>	Anchor the empty cabinet to the premises wall.
<input type="checkbox"/>	Thread the cabling into the cabinet.
<input type="checkbox"/>	Reattach the backplate to the cabinet.
<input type="checkbox"/>	Secure the cabling to the terminals.
<input type="checkbox"/>	Place standby batteries in the base of the cabinet and connect them to the power supply.
<input type="checkbox"/>	Reconnect the ribbon and ground cables.
<input type="checkbox"/>	Reattach the fascia and door.
<input type="checkbox"/>	Apply power to the panel from the AC source.
<input type="checkbox"/>	Program the panel.
<input type="checkbox"/>	Test the installation.

Preparing for Installation

1. Refer to the checklist provided above before beginning the installation process. For detailed information, refer to the appropriate, referenced section in this document.
2. Select a suitable operation environment. The site should be clean, dry, and not subject to shock or vibration. Ensure that the environment is free from wire ends, knockout tabs, and other debris.
3. Familiarize yourself with the panel and components.

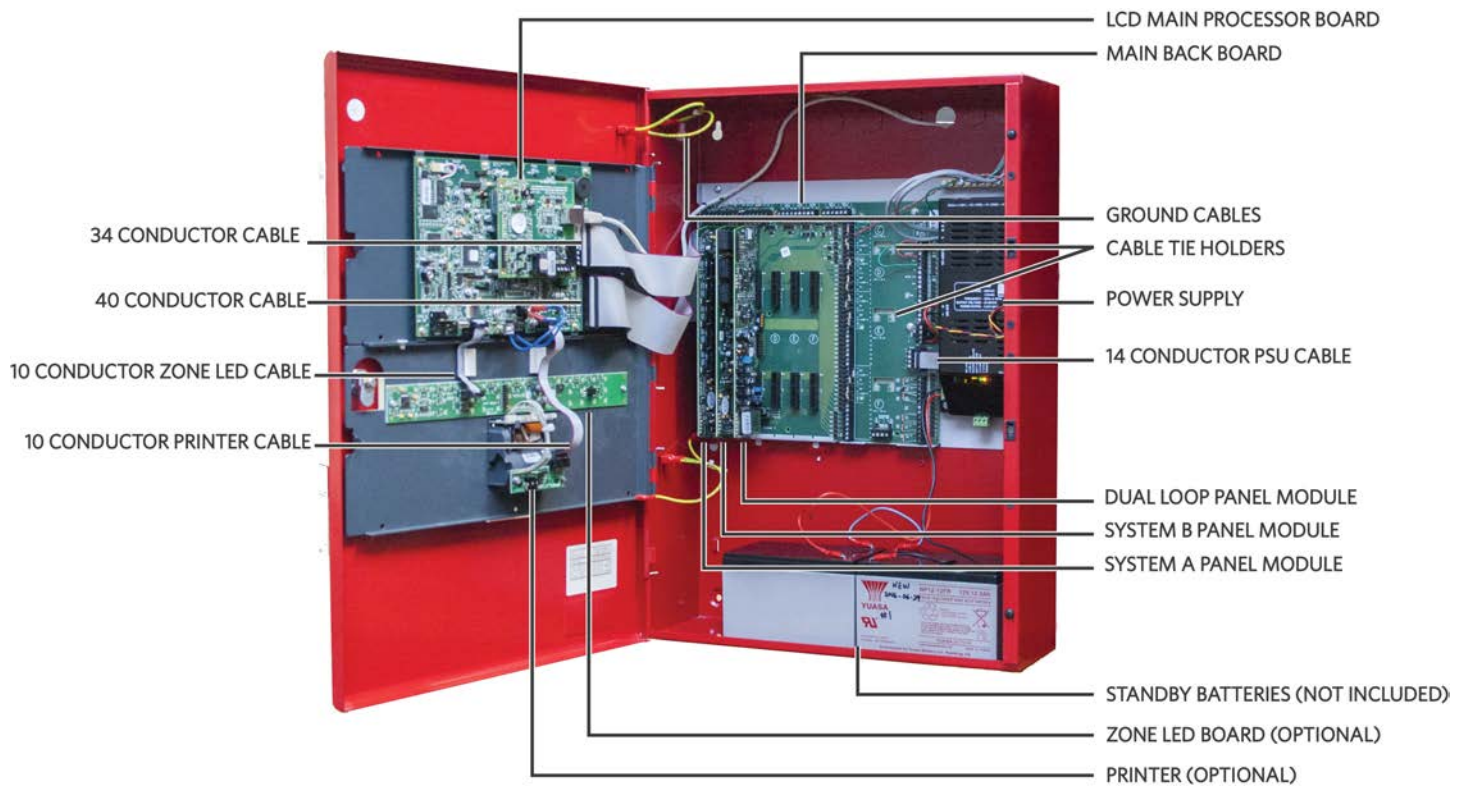

Item	Description
Power Supply	Depending on the model, the FireNET L@titude Fire Alarm Control Panel will have either a 5.25 Amp or 10.25 Amp power supply.
Main Back Board	The Main Back Board contains slots for six circuit boards, and accepts the System A Panel Module, System B Panel Module, Dual Loop Panel Module(s), and various optional panel modules.
LCD Main Processor Board	The LCD Main Processor Board provides operation of the panel GUI.
System A Panel Module	System A Panel Module is required for operation of the fire alarm control panel. All models of the FireNET L@titude Fire Alarm Control Panel contain one System A Panel Module.
System B Panel Module	System B Panel Module is required for operation of the fire alarm control panel. All models of the FireNET L@titude Fire Alarm Control Panel contain one System B Panel Module.

Item	Description
Dual Loop Panel Module	The Dual Loop Panel Module provides two addressable loop functions for the fire alarm control panel. All models of the FireNET L@titude Fire Alarm Control Panel contain at least one Dual Loop Panel Module.
Ground Cable(s)	Ground cabling is green and yellow, insulated wire containing connecting lugs. Ground cabling provides common electrical grounds of the cabinet to the lid, fascia, and backplate.
14 Conductor PSU Cable	The 14 Conductor PSU Signal Cable connects from the power supply to the Main Back Board.
34 Conductor Cable	The 34 Conductor Cable connects the Main Back Board to the LCD Main Processor Board.
40 Conductor Cable	The 40 Conductor Cable connects the Main Back Board to the LCD Main Processor Board.
10 Conductor Zone LED Cable (optional)	The 10 Conductor Zone LED Cable connects from the Zone LED Module to the LCD Main Processor Board.
10 Conductor Zone LED to LED Cable (optional)	The 10 Conductor Zone LED to LED Cable connects from one Zone LED Module to the next Zone LED Module. This cable is required when two or more Zone LED Modules are installed on the fascia.
10 Conductor Printer Cable (optional)	The 10 Conductor Printer Cable connects the printer assembly to the LCD Main Processor Board.

4. The following items are not included with the FireNET L@titude Fire Alarm Control Panel, but may be required for the installation:
- Two 12 VDC VRLA (Valve-Regulated Lead Acid) Standby Batteries - Required
 - Mounting Hardware - Mounting hardware that secures the panel to the wall is not provided. Screws should be either a #10 or #12.
 - A Ground Strap is required for handling circuit boards.

Mounting the FireNET L@titude Fire Alarm Control Panel

IMPORTANT! Electronic components within the panel are vulnerable to damage from electrostatic discharge. Ground straps must be worn by installers before handling circuit boards to prevent damage from electrostatic discharge.

Mount the cabinet box on a flat, dry surface and align it so that it is at eye-level with the center of the panel GUI. Use the cabinet box as a template and mark the position of the mounting holes while ensuring that the wall is flat at the chosen location.

The FireNET L@titude Fire Alarm Control Panel must be mounted in an accessible location. It must not be mounted in another enclosure or near sources of excessive heat. The FireNET L@titude Fire Alarm Control Panel is intended for indoor, dry use only.

Use knockout tabs of the cabinet box to route external cabling into the panel.

IMPORTANT! Drilling additional holes in the cabinet will void the product warranty.

Removing Cabinet Components

Remove the fascia, lid, backplate, and batteries before mounting the cabinet box. The fascia contains the LCD Main Processor Board and, optionally, Zone LED indicators and a printer. The backplate contains the Main Back Board, power supply, and grounding terminals. To remove these components:

1. Disconnect the four ground jumper cables from the cabinet.

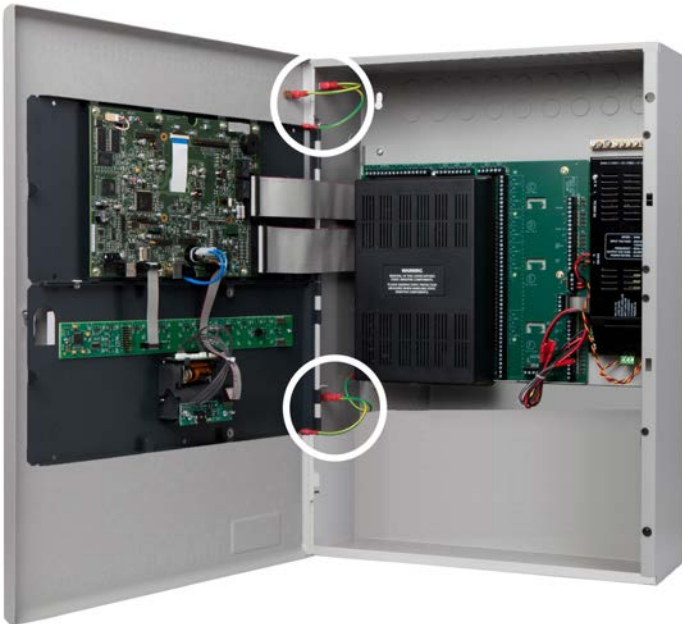

2. Disconnect the ribbon cables from the LCD Main Processor Board, leaving the cable ends connected to the Main Back Board.



3. Remove the hinge pins of the fascia and then remove it from the cabinet box. Return the hinge pins to the hinges of the cabinet box for safekeeping.



4. Remove the hinge pins of the cabinet lid and then remove the cabinet lid from the cabinet box of the fire control panel. Return the two hinge pins to the hinges of the cabinet box for safekeeping.
5. Remove the retaining screws from the backplate, slide the backplate tabs up, and remove the backplate from the cabinet. The empty cabinet box is now prepared for mounting on the premises wall.
6. If the power supply is not mounted to the backplate (as with an extension board), disconnect the power supply and remove it from the cabinet.
7. Mark hole locations on the wall for mounting the empty cabinet.
8. Drill four holes in the premises wall.
9. Anchor the empty cabinet box to the wall using appropriate mounting hardware to secure it.
10. Remove the necessary number of knockout tabs from the cabinet box and feed external cabling into the FireNET L@titude Fire Alarm Control Panel.

Replacing Cabinet Components

1. Replace the backplate and power supply.
2. Replace the door and fascia.
3. Reconnect the cabling.

Connecting and Dressing Cabling

This section describes connections between the power supply and the Main Back Board of the FireNET L@titude Fire Alarm Control Panel. Separate high and low voltage wiring in the enclosure with a minimum gap of 0.25".

Connecting 24V and 14 Conductor Wiring

Refer to [Connecting Field Wiring](#) for specific details about proper wiring. To connect 24V wiring of the power supply to the Main Back Board:

1. Connect the red wire from the positive (+) 24V terminal of the power supply to the positive (+) terminal on the Main Back Board.
2. Connect the black wire from the negative (-) RTN terminal of the power supply to the negative (-) terminal on the Main Back Board.
3. Connect the 14 Conductor Cable from the power supply to the Main Back Board.

Installing Power Supplies

FireNET L@titude Fire Alarm Control Panels can be equipped with either a 5.25 Amp or 10.25 Amp power supply. Set DIP switches on the 5.25 Amp and 10.25 Amp Power Supplies before completing the installation process. Refer to [DIP Switch Settings](#). The power supply settings must be performed to establish the optimal charge current of the standby batteries. These power supplies can be set to operate at inputs of 115 VAC or 230 VAC. For more information about the power supplies and their functions, see Power Supplies.

The 5.25 Amp Power Supply

The 5.25 Amp Power Supply contains a jumper setting for changing from 115 VAC to 230 VAC. Check the jumper setting prior to wiring and operating the 5.25 Amp Power Supply with the FireNET L@titude Fire Alarm Control Panel.

Confirm that the 5.25 Amp Power Supply is set for 230 VAC before operating at 230 VAC. Permanent damage of the power supply will result if the 115 VAC jumper setting exists while operating the power supply at 230 VAC.

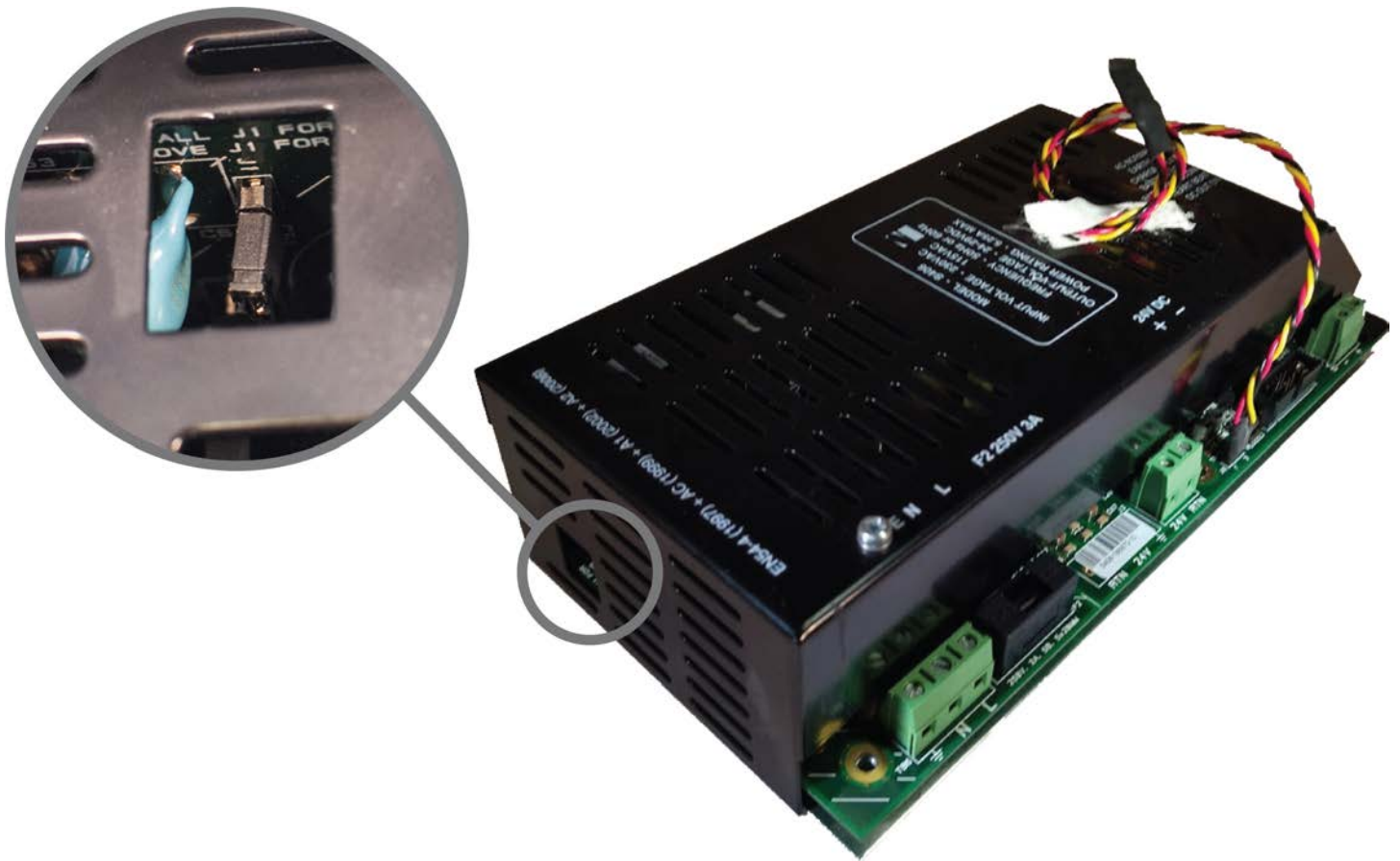

WARNING! Remove jumper J1 before operating the FireNET L@titude Fire Alarm Control Panel at 230 VAC. Failure to remove jumper J1 prior to operating at 230 VAC will cause permanent damage to the 5.25 Amp power supply.

High voltage present on jumper pins. Remove AC power before changing jumper setting.

Voltage	Jumper Required
115	Yes
230	No

Refer to Connecting Field Wiring for specific details about wiring the power supplies. Provide an AC power connection to the terminal block from a 15 Amp branch circuit. The following figure illustrates AC connections of the 5.25 Amp Power Supply:

1. Connect a wire from the ground terminal (\perp) to the grounding block of the cabinet box.
2. Connect a wire from the grounding block of the cabinet box to a ground. Provide this connection in close proximity to the cabinet box.
3. Connect a wire from the neutral terminal (N) to the neutral of the power source.
4. Connect a wire from the line terminal (L) to the line of the power source.

The 10.25 Amp Power Supply

Unlike the 5.25 Amp Power Supply, the 10.25 Amp Power Supply does not require a jumper to switch between 115 VAC and 230 VAC. The 10.25 Amp Power Supply provides an auto-detect feature that automatically compensates for input voltages of 115 VAC or 230 VAC.

Provide an AC power connection to the terminal block from a 15 Amp branch circuit. To connect AC power to the 10.25 Amp Power Supply:

1. Connect a wire from the ground terminal (\perp) to the grounding block of the cabinet box.
2. Connect a wire from the grounding block of the cabinet box to a ground. Provide this connection in close proximity to the cabinet box.
3. Connect a wire from the neutral-terminal (N) to the neutral of the power source.
4. Connect a wire from the line-terminal (L) to the line of the power source.

Connecting Standby Batteries

The FireNET L@titude Fire Alarm Control Panel provides connections for two standby batteries. Refer to Calculations for determining the minimum required battery capacity for the fire alarm system. If the required battery capacity exceeds the space available in the cabinet, an appropriately-sized auxiliary UL listed battery cabinet suitable for fire alarm service will be required. If needed, install that cabinet (wired close-nippled) adjacent to the panel to minimize battery lead length.

WARNING! Battery terminals and leads are not power-limited. Shorts can cause a fire or an explosion. Use extreme caution while connecting standby batteries.

Refer to Connecting Field Wiring for specific details about connecting the standby batteries.

1. Place two 12 VDC, VRLA, rechargeable, standby batteries in the base of the cabinet.
2. Orient terminals of the standby batteries so that the positive (+) terminal of one standby battery is facing the negative (-) terminal of the other.

3. Connect the black wire of the power supply to the negative (-) terminal of Battery 1.
4. Connect the red wire of the power supply to the positive (+) terminal of Battery 2.
5. Connect the jumper wire from the (+) of Battery 1 to the (-) of Battery 2.
6. Route battery leads at least 0.25" from all other cabling.

The series connection described provides the 24 V standby voltage required by the panel. Do not connect the two batteries in parallel. A parallel connection will not provide the 24 V required for operating the panel in a standby condition.

The battery connections can be made while AC power on or off. If AC power is off, the battery connection will not be recognized (and the unit will remain unpowered) until AC is restored. Once AC power is on and the batteries are connected, examine the [LED Status Indicators](#) on the power supply:

- Confirm that the AC NORMAL and DC OUT ON indicators are both illuminated, and the HEARTBEAT indicator is blinking yellow.
- Confirm that BATTERY DISCON is off. If it is on, recheck the battery connections and test or replace the batteries.
- Wait 3 minutes and confirm that no trouble indicators are illuminated.

Using a volt meter, measure the voltage across each battery separately. Typically, the voltage of each battery will measure 12.0 to 14.5 volts depending on the level of charge. Voltages below 12.0 are possible if the battery is severely discharged. Compare the two battery voltages. A difference of more than 1 volt may indicate a problem with the batteries.

Installing Optional Panel Modules

Panel modules are installed at the factory according to customer requirements. In some situations, it may be necessary to install additional panel modules to satisfy site configuration requirements. This section describes procedures for installing and configuring panel modules. Before installing optional panel modules, check and set the DIP switch settings, if applicable.

DIP Switch Settings

Each panel module of the FireNET L@titude Fire Alarm Control Panel must contain a unique setting before being connected to the Main Back Board. The binary setting of the DIP switch sets the specific address for the panel module. The numeric order of the address setting between modules does not impact operation, but each panel module must be assigned a separate / unique address.

The black portion of the DIP switch identifies the switch actuator.

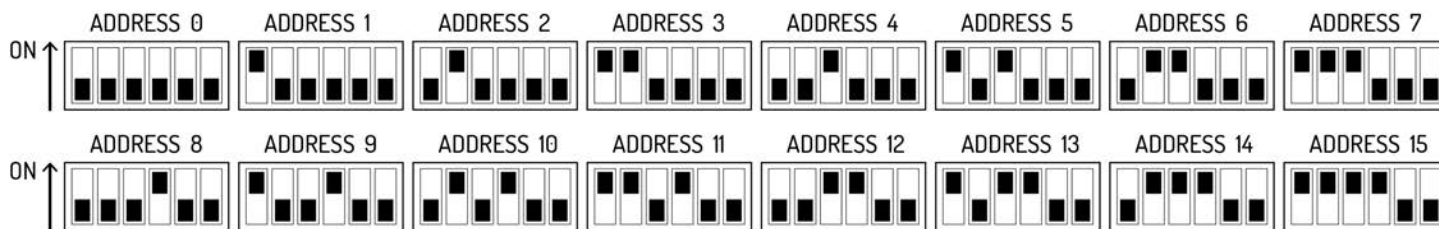

Address 0 is shown above for illustrative purposes only. Address 0 should never be used.

For addresses above 15, switches 5 and 6 will need to be used.

- For address 16-31, switch 5 should be in the ON position. Switch 5 ALONE adds 16 to the address number. For example, for address 20, set the switch position to address 4 shown above and switch 5 in the ON position.
- For address 32-47, switch 6 should be in the ON position. Switch 6 ALONE adds 32 to the address number.
- For address 48-63, switches 5 AND 6 should be in the ON position. Switches 5 and 6 TOGETHER adds 48 to the address number.

Placement

To install modules on the FireNET L@titude Fire Alarm Control Panel:

1. Disconnect AC power and standby batteries prior to performing the module installation.
2. Remove the retaining screw and plastic cover.



- 3. Remove the panel module from the protective packaging using adequate electrostatic protection.
- 4. Point the conductor side of the panel module toward the backplate.
- 5. Insert the notched end of the panel module in the metal guide notch of the backplate at an angle, as shown.

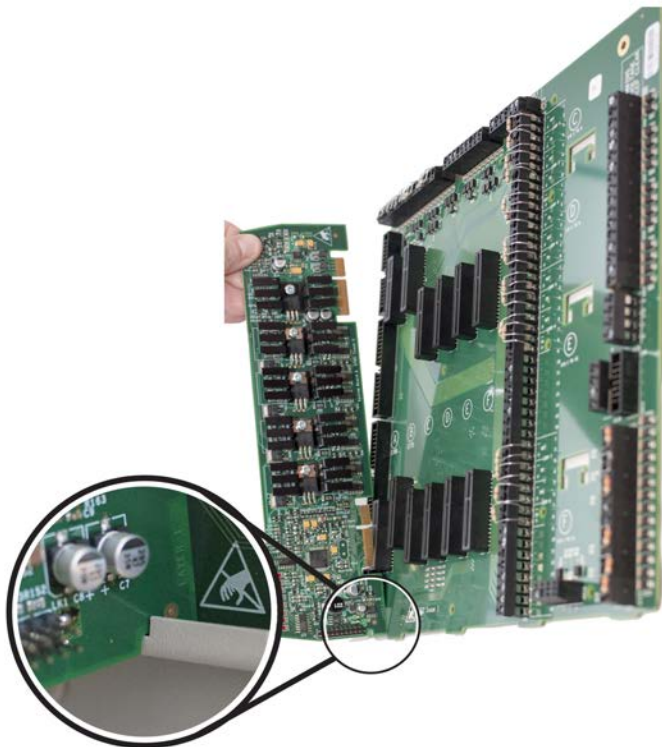

The photo above is an example of panel module placement and may not be representative of the specific module and slot placement described in this guide. Refer to the checklist above for details on placement.

6. Rotate the panel module until all conductors are securely inserted into connectors of the Main Back Board.
7. Replace the cover onto the Main Back Board.
8. Reconnect the batteries and restore AC power.

Installing the Network Module

The Network Module provides enhanced high-speed communication for networking up to 127 fire control panels, (addressed from 1-127). To install the network module of the FireNET L@titude Fire Alarm Control Panel:

1. Switch off AC power and disconnect the battery .
2. Connect the 40 conductor connector of the Network Module to the 40 conductor connector of the LCD Main Processor Board as shown.

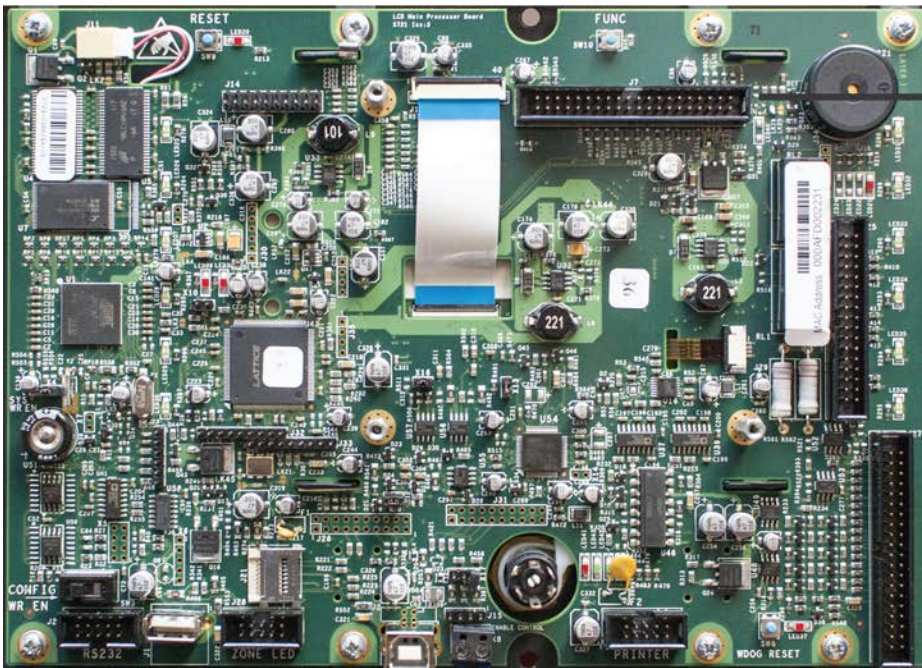

40 CONDUCTOR CONNECTOR FOR CONNECTING THE NETWORK MODULE

3. Secure the Network Module to the LCD Main Processor Board with supplied hardware .
4. Reconnect the battery and restore AC power.

Network Connections

Provide network connections to NETWORK IN and NETWORK OUT terminals of the FireNET L@titude Fire Alarm Control Panel's Main Back Board after installing the Network Module. The following figure illustrates the typical network connections of a 3 panel, Class X network:

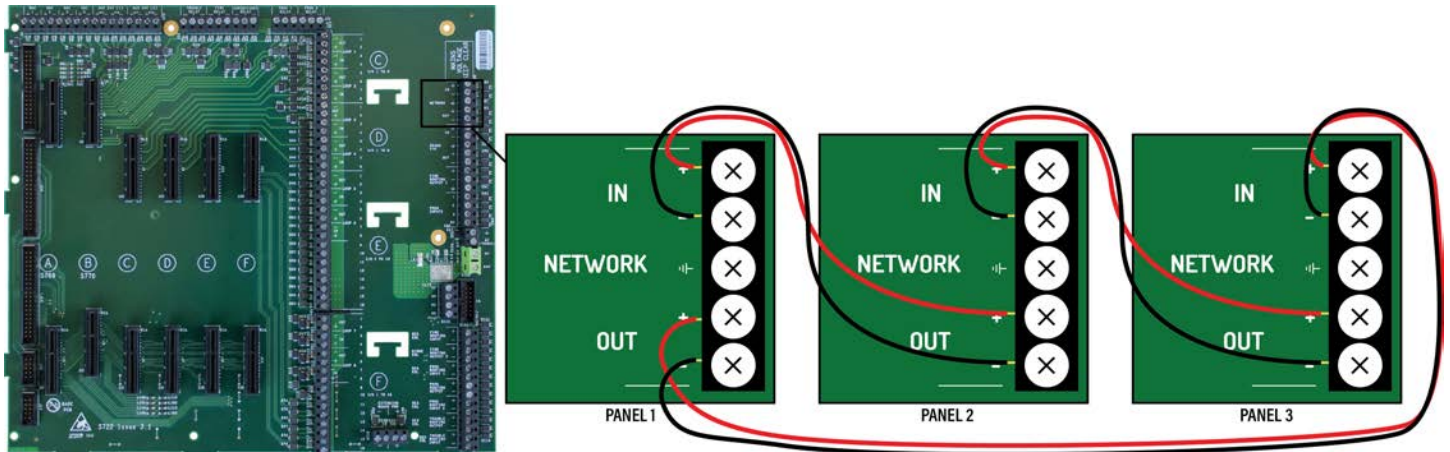

Because network connections are supervised, if a network module is installed and there are no other devices on the network, the IN and OUT network terminals must be connected together to prevent an OPEN CIRCUIT TROUBLE indication.

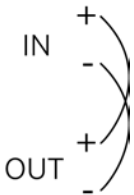

Bridge networking is supported for FireNET and FireNET Plus panels. Advanced features are not available when using bridge networking.

Fiber Optic Networking

When designing or installing a network of panels, any network segment or combination of segments can be connected with fiber optic cable instead of copper wire. Two fiber optic converters are required per segment as shown. Connections between the panel and the converter must be within 20 feet and wired in conduit (or equivalently protected against mechanical injury). Converter DIP Switch settings must be set as shown. Refer to the Equipment List for the model numbers of the fiber converters.

	Single-Mode	Multi-Mode
Fiber Types	9/125 μm, 8.3/125 μm, 7/125 μm, or 10/125 μm	50/125 μm, 62.5/125 μm, or 100/140 μm
Wiring Distance	24.8 miles (40 km)	3.1 miles (5 km)

Serial Connection RS-485-2W		Built-in 120 Ohm Terminator Enable		Fiber Mode Point-to-Point Mode	
SW1	SW2	SW3		SW4	
OFF	ON	ON		OFF	

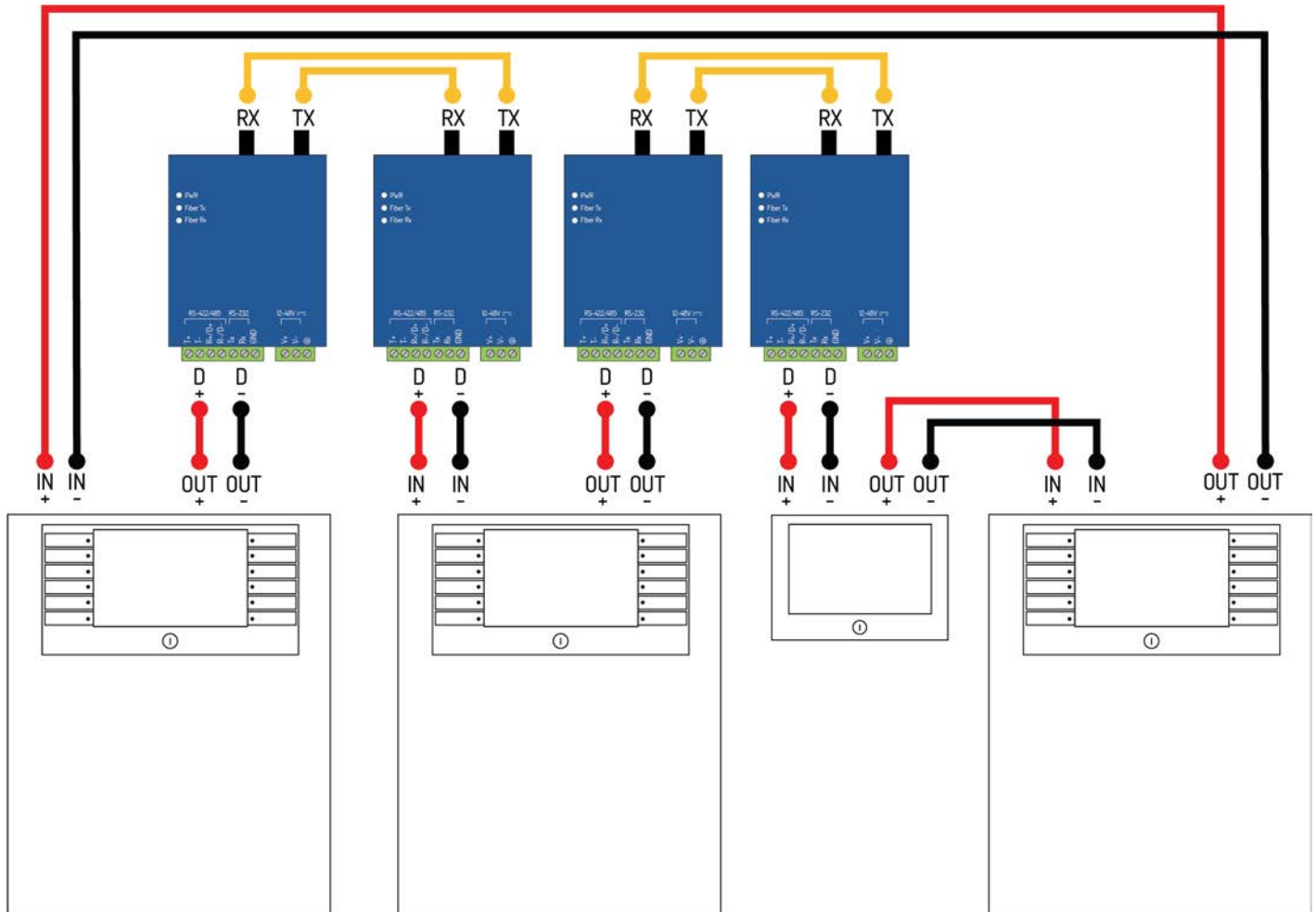

Example Wiring Diagram of a Mixed-Wire (fiber and copper) network

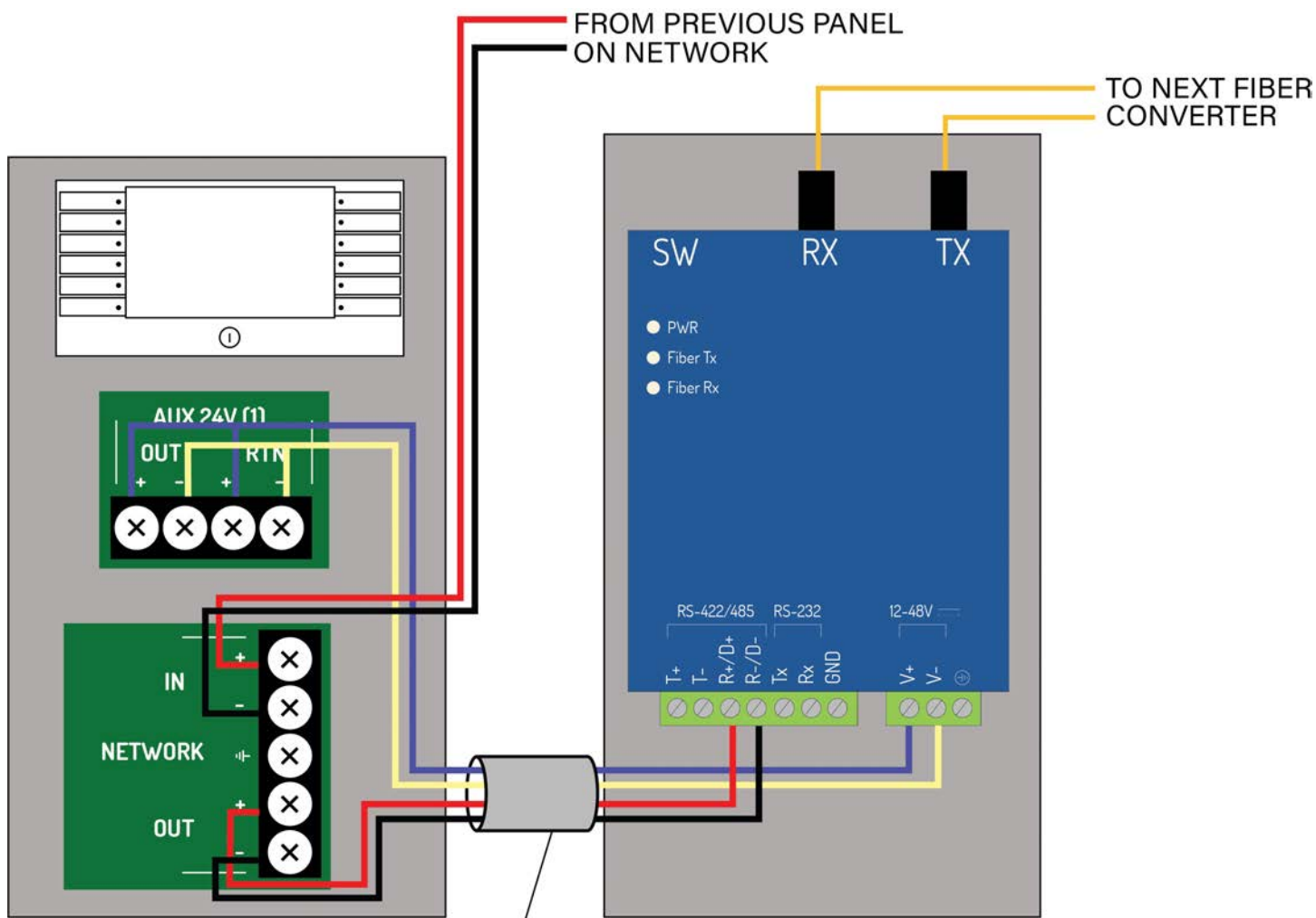

Connections between the panel and the converter must be within 20 feet and wired in conduit (or equivalently protected against mechanical injury).

Detailed Fiber Converter Wiring Diagram

Do not insert more than one conductor per terminal. Use wire nuts or other suitable splice connectors to connect the 24V DC cables to both the AUX 24V OUT and RTN terminals.

Connecting Field Wiring

Power-limited conductors must be installed using Types FPL, FPLR, FPLP, or equivalent cables. When connecting field wiring, separate high and low voltage wiring in the enclosure with a minimum gap of 0.25".

WARNING! Disconnect AC and battery power before making any field connections.

WARNING! Do not route low-voltage cabling through the same conduit as AC lines. AC power lines should be threaded through a dedicated conduit. Refer to the following illustration when connecting any wiring.

Wiring Diagram

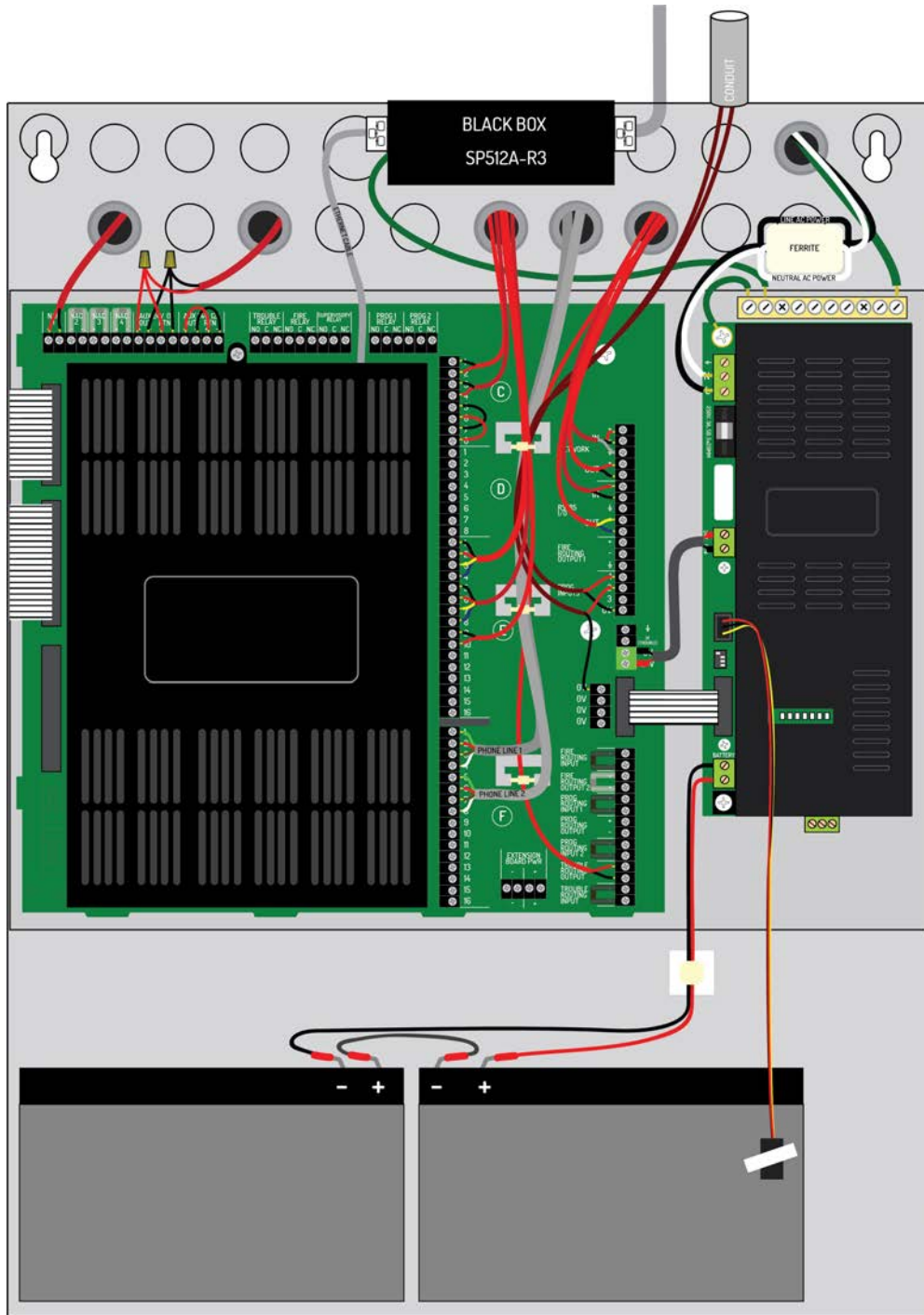

Class A SLC Loops

1. Connect Class A loops to the terminal strip of the FireNET L@titude Fire Alarm Control Panel.
2. When the loop is unused, the loop termination jumpers provided with the panel should be replaced with 14-22 AWG SLC cable.

The FireNET L@titude Fire Alarm Control Panel provides a trouble signal when unused loops are not terminated. All loops are supervised.

Follow NFPA guidelines for placement of isolators with Class A wiring.

CLASS A LOOP CONNECTION CONTAINING SIX ADDRESSABLE SENSORS

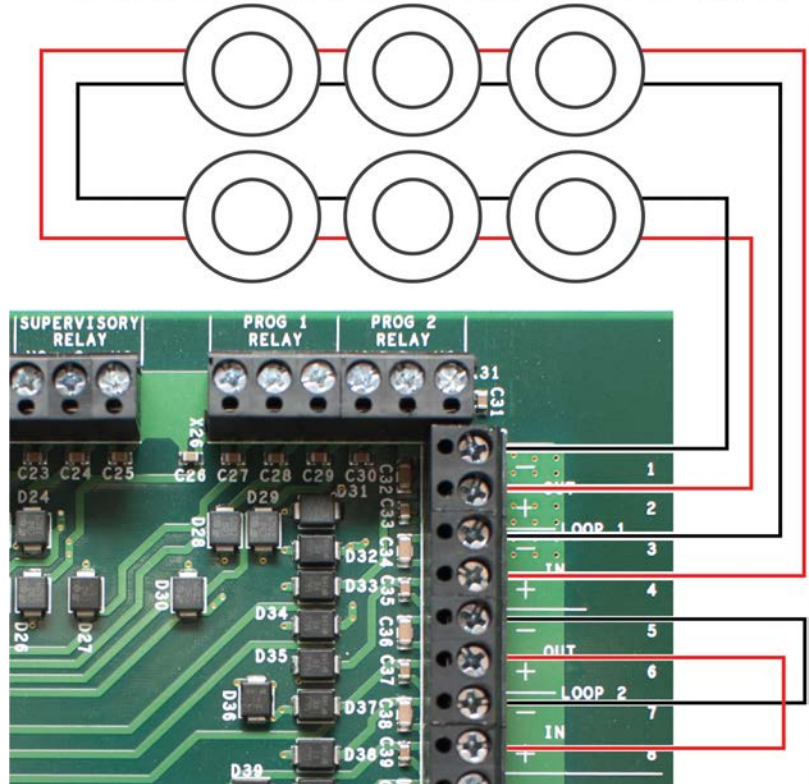

Class B SLC Loops

Class B loops may not be permitted in all regions. Check local codes of practice before using Class B SLC circuit configurations.

1. Connect Class B loops to both the IN and OUT terminals of the terminal strip. Do not insert more than one conductor per terminal. Use wire nuts or other suitable splice connectors to connect the Class B loop cable to both the IN and OUT terminals.
2. When the loop is unused, the loop termination jumpers provided with the panel should be replaced with 14-22 AWG SLC cable.

SLC cabling must be sized according to length and device load to ensure that the voltage-drop of the cable does not result in an inadequate operating voltage on the circuit.

Refer to the FireNET L@titude Fire Alarm Control Panel Installation Manual (MAN-1431HA) for an example of how isolators may be used on a Class B circuit.

CLASS B LOOP CONNECTION
CONTAINING THREE ADDRESSABLE SENSORS

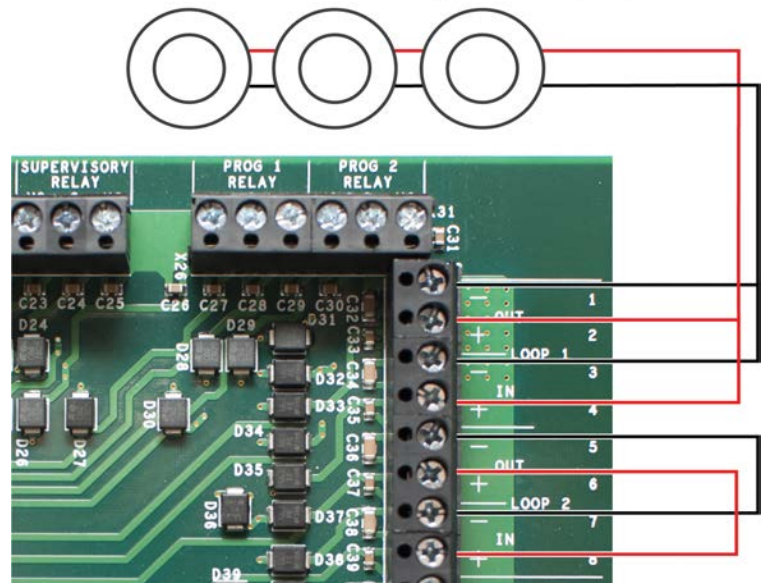

Class X SLC Loops

1. Connect Class X loops to the terminal strip of the FireNET L@titude Fire Alarm Control Panel.
2. When the loop is unused, the loop termination jumpers provided with the panel should be replaced with 14-22 AWG SLC cable.

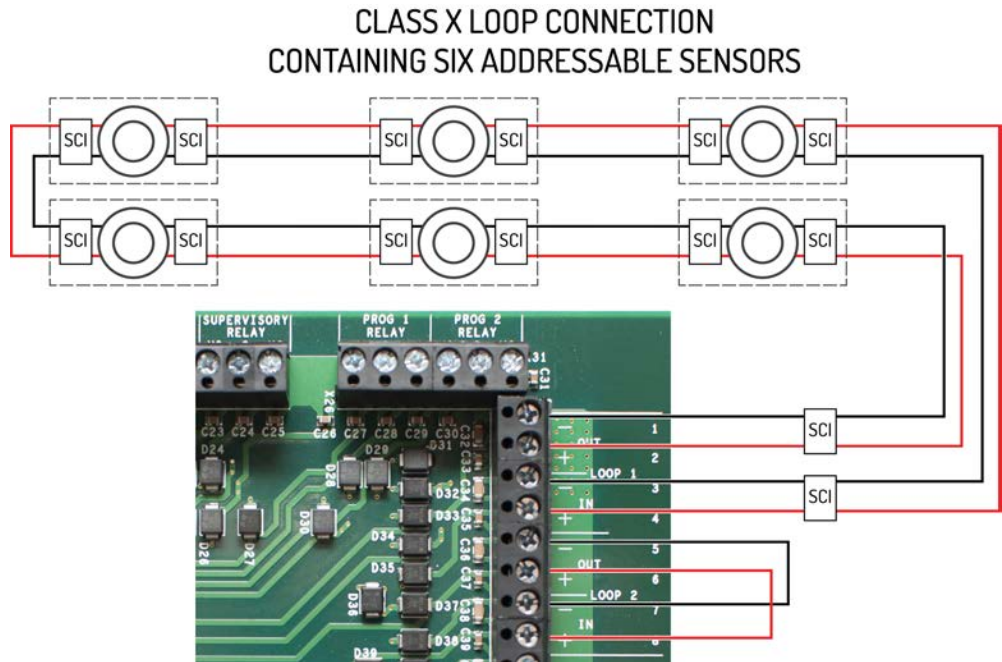

The FireNET L@titude Fire Alarm Control Panel provides a trouble signal when unused loops are not terminated. All loops are supervised. Follow NFPA guidelines for placement of isolators with Class X wiring.

When using Class X wiring, SCI Short Circuit Isolators must be installed before and after each analog addressable device on the SLC loop. Alternatively, analog devices with built-in SCI may be used.

The wiring from the control panel to the first SCI and from the last SCI back to the control panel must be in conduit.

Notification Appliances

Notification appliance circuits can be configured in pairs for Class A operation. Class A operation can be assigned to the first pair of notification appliance circuits (NAC1&2) or the second pair (NAC3&4) or both pairs.

When wiring a pair of NACs for Class A operation, only one of the two End-of-Line diodes is used. Remove the one from the +/- terminals of the first NAC. Leave the other in-place on the terminals of the second NAC.

For Class B operation, the End-of-Line diode must be removed from the NAC terminals and connected across the terminals of the last device on the NAC circuit.

Branching of Class A or Class B notification appliance circuits prevents proper circuit supervision and is not permitted.

Connecting Notification Appliances

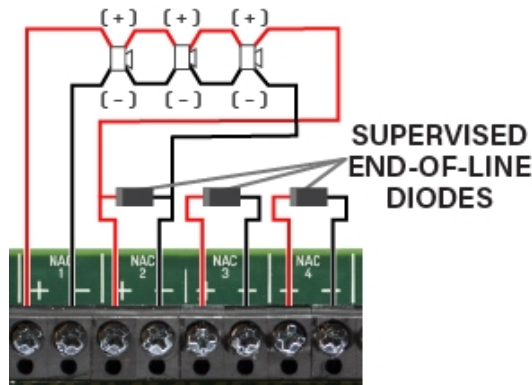

Connection of notification appliances in a Class A configuration.

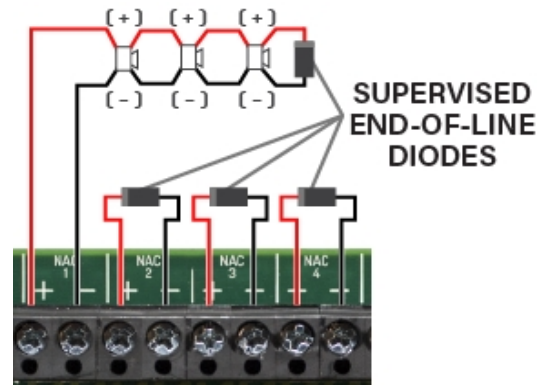

Connection of notification appliances in a Class B configuration.

Do not insert more than one conductor per terminal. Use wire nuts or other suitable splice connectors to connect the end-of-line diode and Class A loop return wire. Cable gauge must be sized according to length and device load to ensure that voltage-drop of the cable does not result in less than the minimum operating voltage of the notification appliances. Different limitations will apply for devices with a higher or lower minimum working voltage. Refer to Specifications for cabling information.

To install notification appliances on the FireNET L@titude Fire Alarm Control Panel:

1. Connect notification appliances and End-Of-Line diodes to the NAC output.
2. Connect End-Of-Line diodes to unused NAC outputs.
3. Maintain the limit for maximum wire length of the circuit.

Notification appliances connected to NAC outputs on a single panel are synchronized. Notification appliances connected to SLC loops on a single panel are synchronized. However, notification appliances on separate panels are not synchronized. Per NFPA 72,

Audible Devices	The installation of one group of synchronized-audible notification appliances shall not be installed in hearing range of another group of synchronized-audible NACs.
------------------------	----------------------------------------------------------------------------------------------------------------------------------------------------------------------

Visual Devices	The installation of one group of synchronized-visual notification appliances shall not be installed in line-of-sight of another group of synchronized-visual notification appliances.
-----------------------	---------------------------------------------------------------------------------------------------------------------------------------------------------------------------------------

Refer to Equipment List for synchronization devices that are UL listed and authorized for use with the FireNET L@titude Fire Alarm Control Panel. Refer to Calculations to determine wire size requirements for your application.

Connections for NAC Power Output Modes

There are 3 NAC power output modes: continuous constant power, door holder, and resettable. NAC power outputs can be wired as 2-wire or 4-wire circuits as shown. When wired using 2-wire configuration, select "Class B" in the configuration menu. When wired using 4-wire configuration, select "Class A" in the configuration menu.

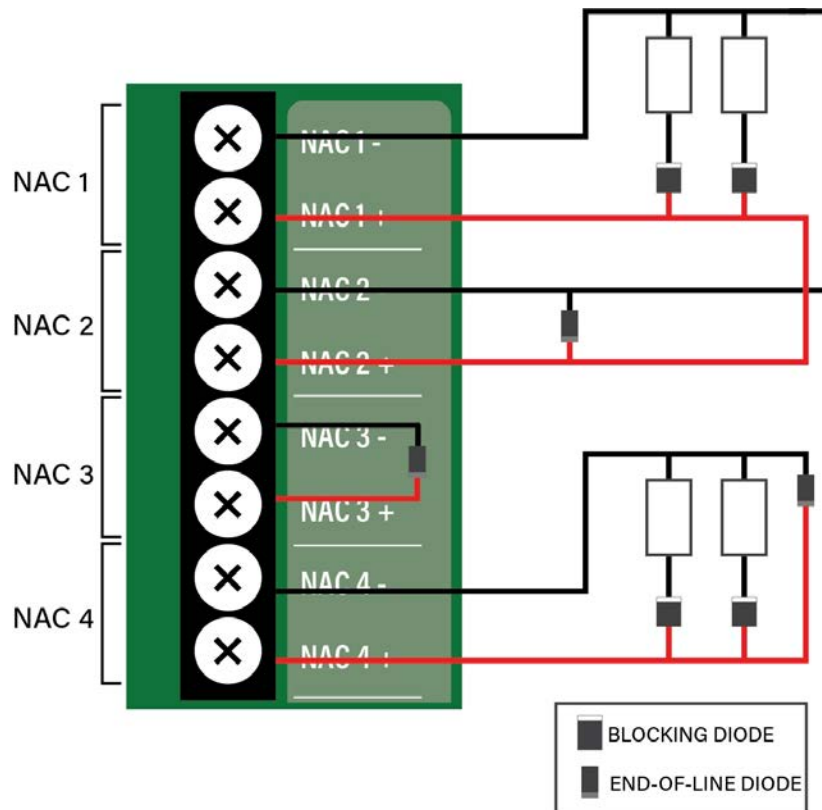

When using a NAC in a power output mode, each device requires a blocking diode (not provided) to be connected in series. These diodes can be any of the following:

- Diodes, Inc., Part No.: 6A1-T
- SMC Diode Solutions, Part No.:6A1TA
- Micro Commercial Co., Part No.: 6A1-TP
- Any equivalent standard silicon diode with parameters of:
 - Radial Lead Diameter: 1.0 mm minimum
 - Peak Reverse Voltage: 40 V minimum
 - Average Forward Rectified Current: 6.0 A minimum

Continuous Constant Power

Regardless of the wiring schema, when the NAC is used in **continuous constant power** mode, it is a special application output with a voltage range of 20.0 - 26.4V. It can be used to power Hochiki ASB and ASB-L sounder bases. When powering these devices, the circuit acts as a Class B pathway. The wiring loss must not exceed 4V. If devices other than those listed are powered by this circuit, the circuit may not meet the Class B supervision requirements.

Door Holder

Regardless of the wiring schema, when configuring for **door holder**, the circuit is a regulated 24V output and meets the requirements for a Class D circuit.

Resettable

When the NAC is used in **resettable** mode, it is a special application output with a voltage range of 20.0 - 26.4V. It can be used to power the following:

- System Sensor i3 series Models: 4W-B, 4WT-B, 4WTA-B, 4WTR-B, 4WTAR-B, 4WITAR-B
- System Sensor i4 Series Models: COSMO-4W, COSMOD4W
- System Sensor End-of-Line Relay: EOLR-1

When powering these devices, the circuit acts as a Class B pathway only when an EOLR-1 is the last device on the circuit and the relay contacts are supervised. The wiring loss must not exceed 8V. Refer to the **System Sensor Installation Instructions** for wiring information.

AUX 24V 1 and AUX 24V 2

The AUX 24V output terminals provide regulated, non-programmable 24V DC for powering ancillary devices such as loop modules, I/O boards, and remote displays. The outputs are fused at 900 mA and include a maximum load rating of 900 mA. Outputs of AUX 24V 1 and AUX 24V 2 are also supervised for circuit trouble conditions.



Wiring gauge on AUX 24V 1 or AUX 24V 2 outputs must be sized as a function of cable length and device load to ensure that voltage-drop of the cable does not result in less than the minimum operating voltage at the ancillary devices.

Connect the ancillary devices to the OUT terminals. The OUT terminals supply 24V power and provide short circuit monitoring.

Connect RTN terminals to the last ancillary device. The RTN terminals provide open circuit monitoring.

If open circuit monitoring is not required, the RTN terminals must be connected to the OUT terminals to prevent reporting of OPEN CIRCUIT TROUBLE.

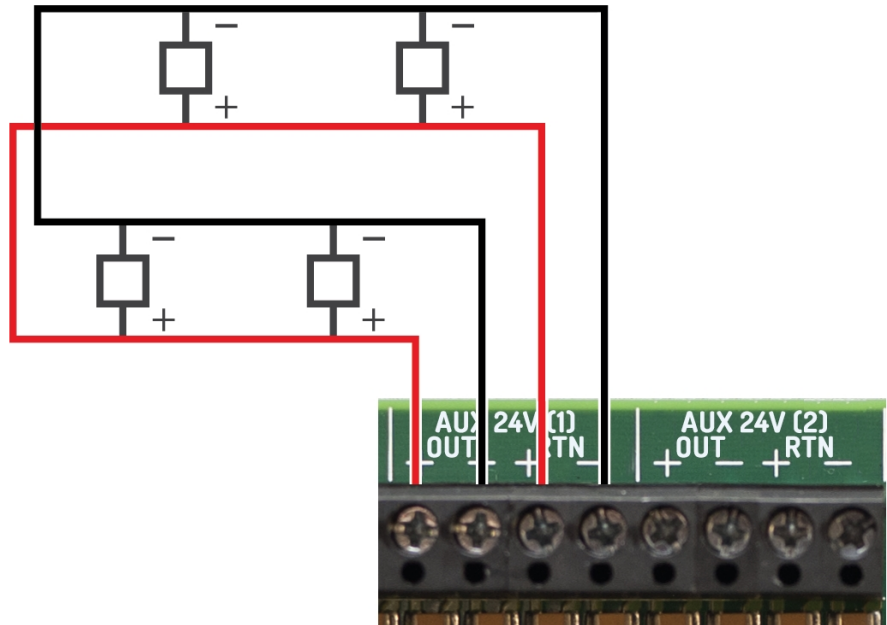

This illustrates a Class B circuit that provides open circuit monitoring.

Relay Contacts

The FireNET L@titude Fire Alarm Control Panel contains five programmable relays that provide volt-free changeover. These relays include:

TROUBLE RELAY	Activates on any trouble and clears when all troubles are clear.
FIRE RELAY	Activates on any fire condition and remains active until all fire conditions are clear.
SUPERV RELAY	Activates on any supervisory condition and remains active until all supervisory conditions are clear.
PROG 1 RELAY	User-definable. Not programmed by default.
PROG 2 RELAY	User-definable. Not programmed by default.

Each relay has three volt-free changeover contacts labeled NO, COM, and NC respectively.

Dry contacts between the NO terminal and the COM terminal are open when the output is inactive, and closed when the output is active.

Dry contacts between the NC terminal and the COM terminal are closed when the output is inactive, and open when the output is active.

Each relay can be configured independently through Loop Explorer 2 or the panel GUI using Access Level 3. Refer to the [Programming the Panel](#) for LE2 information. Refer to Specifications for operating characteristics of these field terminals.

Network

These terminals provide Class X connections for intra-panel and annunciator networking and allow for individual panels to communicate the following data with each other:

1. Trouble, Supervisory signals
2. Alarms: CO, Fire
3. Other events tab information

Data passed can be reported at each panel GUI and trigger panel responses such as the buzzer or fire alarms. Networked panels that go off-line will appear as missing at networked panels. Refer to [Network Connections](#) for wiring information.

RS-485 I/O

These terminals provide data communication between the panel and legacy products, such as the [16 Channel I/O Interface Card](#). Connections are:

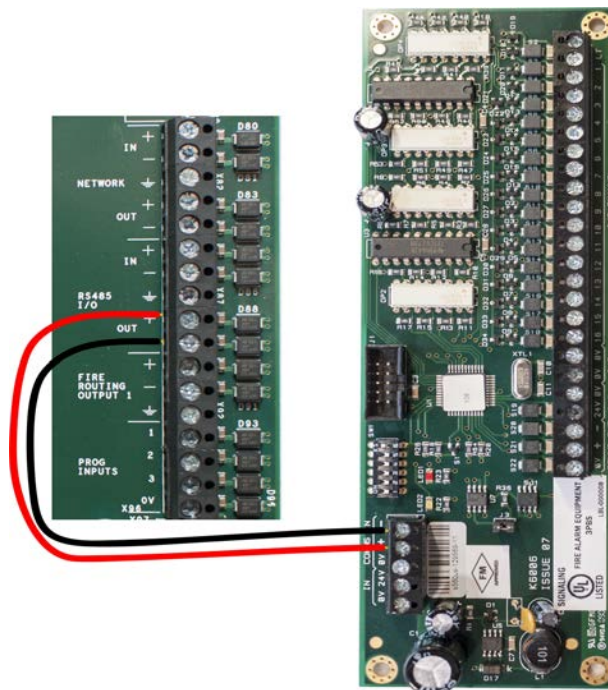

Fire Routing Output 1

Reserved for future use.

Prog Input

There are three programmable Inputs (PROG INPUT) and one 0V terminal. The inputs are non-supervised and are designed to be activated by voltage-free contacts. To activate, connect a PROG INPUT to the 0V terminal. Do not insert more than one conductor per terminal. There are additional [0V terminals](#) if needed.

The default configuration of all three programmable inputs is non-latching, transparent. They must be configured to perform a function. The line impedance of the circuit connection to the Prog Input terminals must be less than 50 ohms. Each programmable input can be separately configured to provide actions, delays, zones, and location messaging using the panel GUI.

Terminal	Designation	Condition
1	P1 - Programmable 1	on / off
2	P2 - Programmable 2	on / off
3	P3 - Programmable 3	on / off
4	0V	0 volts

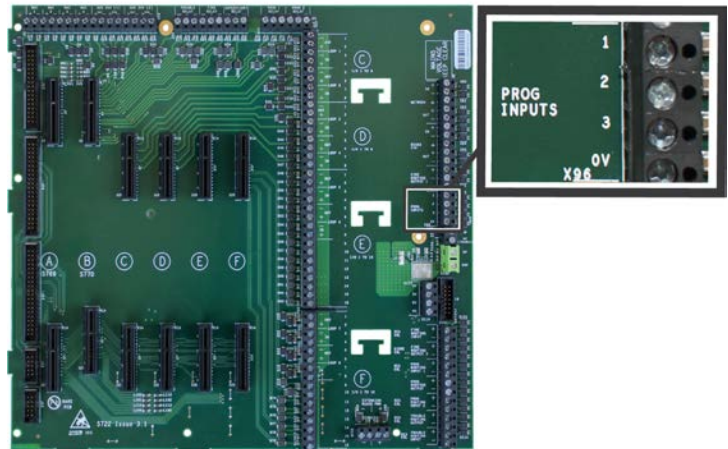

For wiring Programmable Inputs:

- The interconnected equipment must be located in the same room as the FireNET L@titude Fire Alarm Control Panel.
- Wiring must be in conduit (or equivalently protected against mechanical injury) and connections must be made within 20 feet.

Routing I/O Terminals

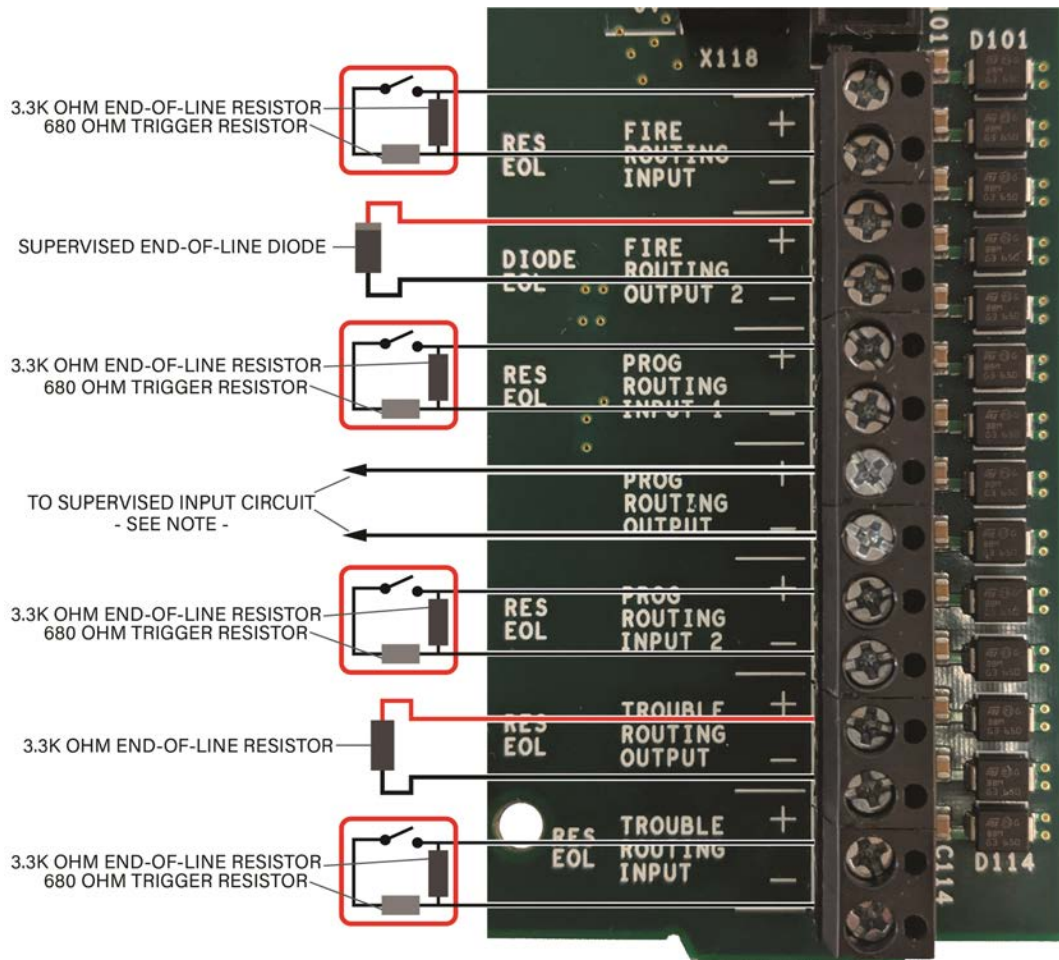

Installing Addressable Devices

This section describes installation requirements and constraints for addressable devices on the FireNET L@titude Fire Alarm Control Panel. The addressable devices described in this section include SLC Devices.

SLC Detector Spacing

Install SLC detectors with spacing as specified in NFPA 72.

SLC Device Detector Sensitivity

SLC device sensitivity is configurable using the panel GUI or LE2. Refer to the [Programming the Panel](#) for LE2 information. Sensitivity levels should be determined and planned in advance.

Detector Calibration / Drift Compensation

Detector calibration automatically occurs once per day. The FireNET L@titude Fire Alarm Control Panel is responsible for drift compensation of individual smoke sensors. It will make automatic sensitivity checks and sensor adjustments once per day.

Addressing an SLC Module

Hochiki Protocol

All SLC modules must have a unique address number that acts as a point of reference for the panel. An SLC module address number can be any number from 1-127. SLC detectors that are paired with compatible SLC sounder bases provide the sounder base with a unique ID of detector address +127.

Addressing an SLC module requires the use of an Analog Device Programmer (not included with the FireNET L@titude Fire Alarm Control Panel). Use the operating instructions when programming each device.

It is not necessary to address sounder bases.

Connecting SLC Devices

Hochiki Protocol

Each SLC device must be connected using S and SC terminals; S to S and SC to SC. Refer to device-specific wiring requirements when connecting each device.

Devices with IN and OUT S and SC terminals should be connected IN to OUT and vice versa.

SC on the device should connect to LOOP (-) on the panel. S on the device should connect to LOOP (+) on the panel.

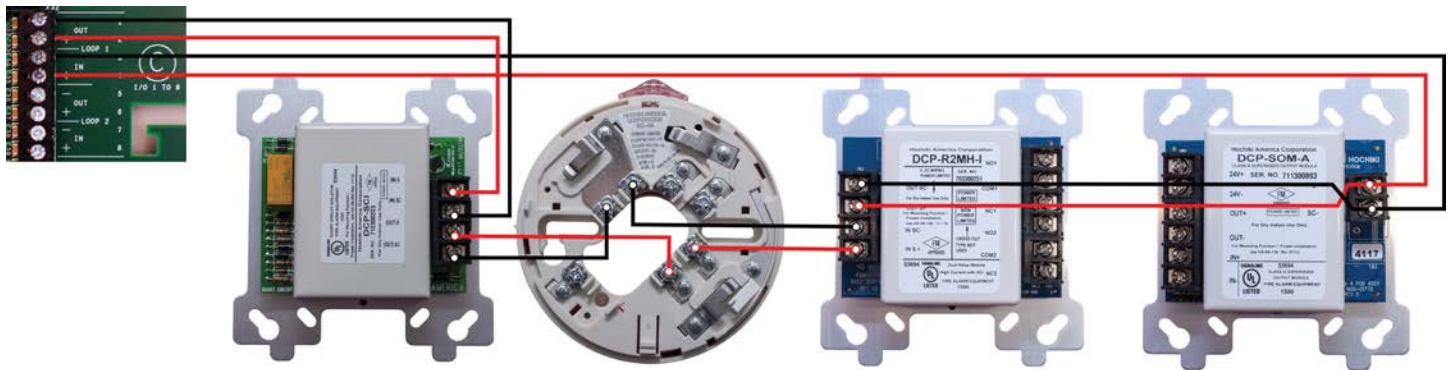

Class A SLC Wiring Example - Hochiki Protocol

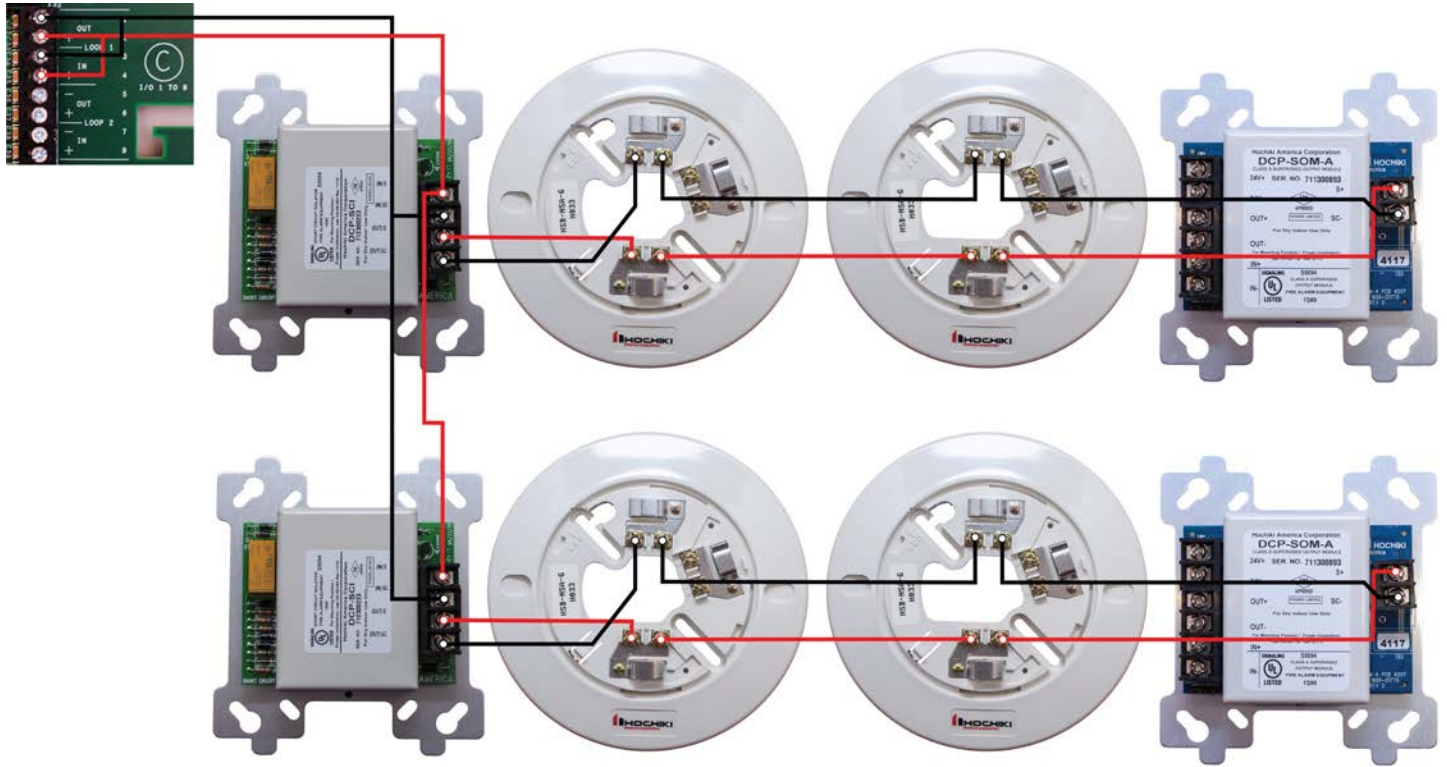

Class B SLC Wiring Example - Hochiki Protocol

SCs should be located at or near the panel.

Installing Municipal Boxes

The figure below illustrates typical municipal box connections of the FireNET L@titude Fire Alarm Control Panel:

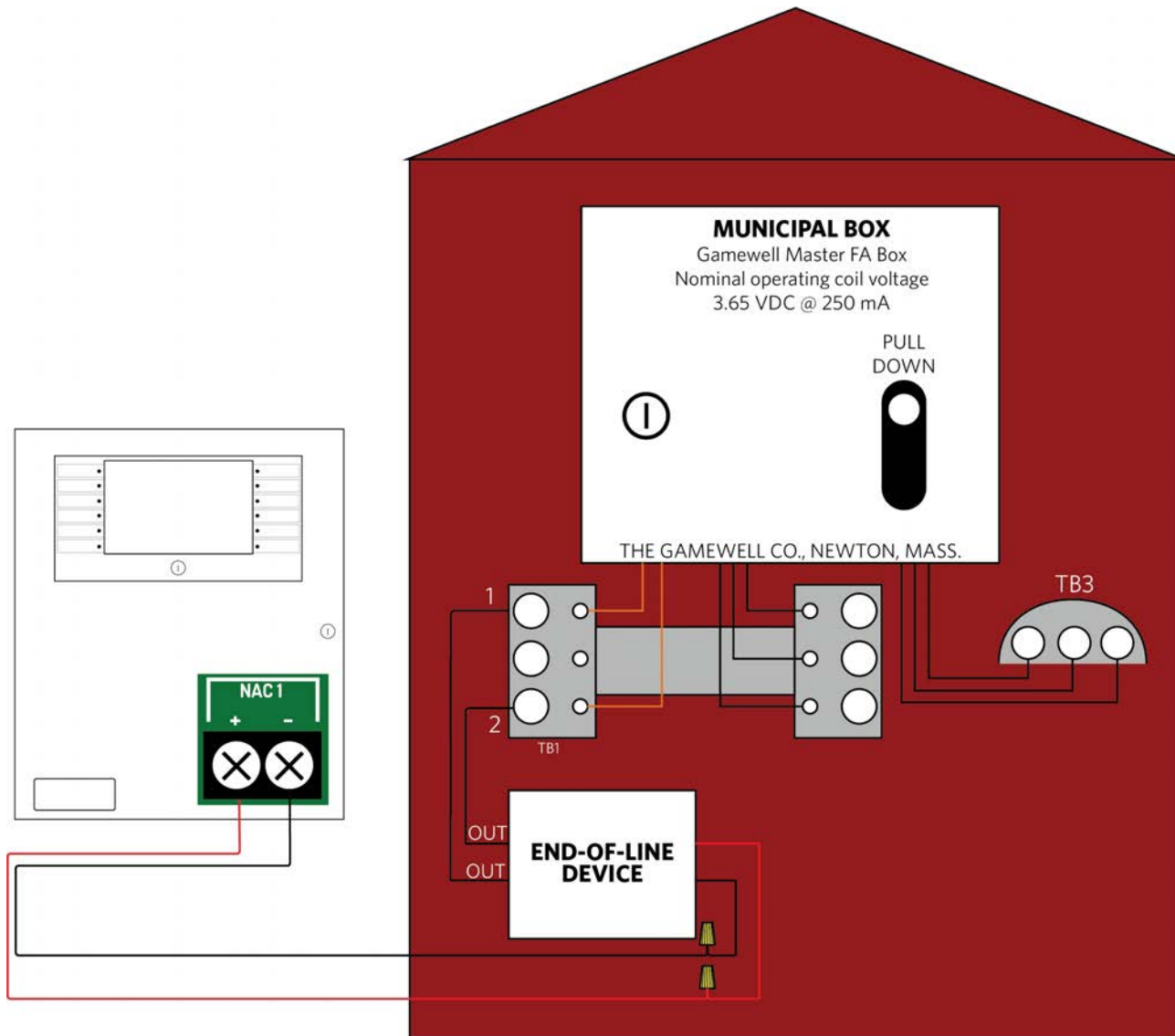

Perform this installation to connect the Gamewell Master F. A. Box for municipal-station notification. Install this product in accordance with NFPA 72, NEC 70, the National Electrical Code and all local codes. The NAC output can provide a non-pulsing, regulated 24 VDC, 2.5A maximum output when a fire condition is reported to the L@titude Panel. The OUT leads of the EOLD (K14070) shall connect directly to the terminal block of the municipal box.

Testing the Installation

Once all field wiring connections are complete, test the power supply, field circuits, and panel GUI to ensure proper operation of the FireNET L@titude Fire Alarm Control Panel.

Panel Start-up

1. Connect the batteries and apply AC power to the FireNET L@titude Fire Alarm Control Panel.
2. Allow the panel to go through its start-up process.
 - Black screen with Bootloader version displayed. (<1 min.)
 - Blank screen. (< 1 min.)
 - Animated loading circle with brief Lamp Test. (< 1 min.)
 - Splash-screen with **Loading Graphics**. (< 1 min.)
3. After **Loading Graphics** clears, press **Controls & Other Events**> **Other Events** to display details of ongoing start-up processes. **Other Events** will always include initialization of the SLC loops, but may include additional items as well, such as **User Logged In** and **Bootloader Update** events.

At this stage, it is common for many trouble events to be reported. The most common is "Unexpected Device". This is a normal part of panel commissioning.

The start-up process is complete when all of the panel's **Other Events** clear.

4. If **Bootloader Update** events were present during the start-up process in step 2, power down the panel and repeat Panel Start-up.

Do not power-down the panel during a Bootloader Update.

- **User Logged In** indicates that a key switch is turned to the Enable position or a user access code has been entered.
- **Bootloader Update** indicates software on panel modules is being updated by the main panel. This typically occurs
 - only when a panel module is changed or the main panel firmware is updated.
- If the panel is part of a network, some status events may reflect the status of other network nodes.

Loading Configuration

1. Load (or import) the appropriate configuration from Loop Explorer 2. After the import, the panel will begin device initialization.

The node address must be set on the panel before importing a configuration from LE2.

2. Press **Controls & Other Events > Other Events** to display details of the ongoing device initialization process.
3. Once initialization is complete, address any outstanding troubles that may be reported.
4. Confirm that the **Fire System Normal** condition is displayed.

Testing the Power Supply

Perform the following tests to confirm operation of the power supply:

1. Apply AC and battery power to the FireNET L@titude Fire Alarm Control Panel.
2. Check that the AC Normal LED is illuminated on the power supply.
3. Check that the Heartbeat LED is flashing on the power supply.
4. Remove AC power and ensure that the standby batteries are powering the fire control panel. The AC Normal LED on the power supply switches off after 30 seconds to indicate the loss of power.
5. Reapply AC power to the FireNET L@titude Fire Alarm Control Panel.
6. Disconnect the red wire from the Standby Battery terminal. The Battery Disconnect LED on the Power Supply illuminates and the fire control panel continues to operate.
7. Reconnect the red wire from the Standby Battery terminal.

Check connections and test voltages at the primary and secondary of the power supply if the panel does not operate as described above.

Testing the Field Circuits

Perform the following field circuit tests to confirm proper connections of the loops, NACs, inputs, and outputs:

1. Connect external devices to field terminal loops, NACs, inputs, and outputs.
2. Confirm that correct connections exist between the batteries and the power supply.
3. Apply AC power to the FireNET L@titude Fire Alarm Control Panel.
4. Perform the **Learn Panel** function on the panel GUI. Buzzer activation occurs when performing the **Learn Panel** function.

Buzzer activation during the **Autolearn Panel** function is part of configuration process. Once Autolearn is complete, the panel will initialize loop devices with the default settings.

5. Once device initialization is complete, address any outstanding troubles that may be reported.
6. Confirm that the **Fire System Normal** condition is displayed following the booting cycle.

A “comms time-out” trouble occurs following the booting sequence when the FireNET L@titude Fire Alarm Control Panel includes a network card. Reset the panel in Access Level 2 of the menu to obtain the **Fire System Normal** condition when this trouble condition occurs.

7. Test and verify that all inputs and outputs operate as intended and in accordance with NFPA 72 guidelines.

Testing the Panel GUI

Perform the following tests to confirm proper operation of the buzzer, panel GUI, indicator lamps, and the fire control panel system.

The **Fire System Normal** screen displays when the FireNET L@titude Fire Alarm Control Panel is operating properly and indicates that the installation was successful. Determine that the **Fire System Normal** condition is visible on the panel GUI before initiating the **Panel Tests**. **Fire System Normal** condition is displayed following the booting cycle and occurs when trouble conditions are not reported.



Panel Tests

Panel Tests are provided through the **No User Group** of the panel GUI. **No User Group** contains a limited set of operations and does not require password authorization to initiate. The **No User Group** menu is immediately available for operation following the booting cycle.

Lamp & Buzzer Test

This test confirms operation of the indicator lamps and the buzzer. To perform the **Lamp & Buzzer Test**:

1. Press the panel GUI during the Fire System Normal condition.
2. Press **Panel Tests** and then **Lamp & Buzzer Test**. The internal buzzer of the fire control panel sounds and all indicator lamps light for 5 seconds. Contact Technical Support if fascia lamps do not light.

Display Test

Perform the **Display Test** to confirm operation of the panel GUI.

1. Press the panel GUI during the Fire System Normal condition.
2. Press **Panel Tests** and then **Display Test**. A confirmation window will appear.

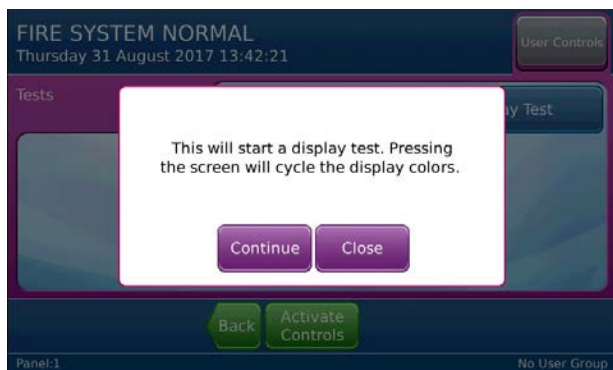

3. Press **Continue** to test the display. The panel GUI cycles through a series of blank raster colors.

System Information

The **System Information** window includes details such as Software Version, File manager, LED Controller, I/O Board Controller, Configuration Manager, and the Event Log. View the System Information to determine the operating status of the FireNET L@titude Fire Alarm Control Panel. To view system information on the FireNET L@titude Fire Alarm Control Panel:

1. Press the panel GUI during the Fire System Normal condition.
2. Press **System Information**. Press **More** to display subsequent System Information windows.

Event Log

View the Event Log to determine the status of initiating devices, signaling line circuits, and notification appliances. To view the Event Log of the FireNET L@titude Fire Alarm Control Panel:

1. Press the panel GUI during the Fire System Normal condition.
2. Press **View Event Log** on the User Controls window.

3. Press **More Details** to display additional information about the posted event message.

Programming the Panel

The FireNET L@titude Fire Alarm Control Panel can be configured in the following ways:

- Panel GUI using access level 3
- Loop Explorer 2 via computer (USB Type B) or USB flash drive (USB Type A).

Most features can be programmed using the panel GUI. However, some advanced features can only be programmed using the Loop Explorer 2 utility.

Loop Explorer 2

Many of the FireNET L@titude Fire Alarm Control Panel features and settings can be configured using the program Loop Explorer 2. Licenses can be obtained through your sales representative. The following features are configurable.

- SLC configuration, including SLC Detector sensitivity, SLC device input action, and SLC device delay.
- Zone settings (Alarm Verification, Pre-Signal, Positive Alarm Sequence)
- Network settings
- Common or Zonal Mode setting
- Panel Module settings
- Panel NACs
- Ring Mode options
- Maintenance date keeping
- Unique device labels (i.e., ALK-V can be renamed “APT 101 Bedroom 1”)
- Unique panel labels (i.e., Node 1 can be renamed “Building 10”)

Troubleshooting

For troubleshooting information, refer to the [VES Network](#) website.

OVERVIEW

The FireNET L@titude Fire Alarm Control Panel provides connections for addressable devices in 2 to 16 loop model configurations. All model configurations support SLC loads up to 400 mA per loop. Networked models can support over 200,000 addressable devices and 65,000 programmable inputs and outputs. A 16 loop model of the panel can support up to 2032 addressable points and 512 additional programmable inputs and outputs.

This manual describes 2 to 16 loop models of the FireNET L@titude Fire Alarm Control Panel. In order for the product to comply with the requirements in the **Standard for Control Units and Accessories for Fire Alarm Systems, UL 864 10th Edition**, certain programming features or options must be limited to specific values or not used at all as indicated below. Refer to Equipment List for the specific models described in this table.

Program Feature or Option	Configurable Range	Range Permitted in UL 864
AC Fail Delay	0 - 1800 minutes in GUI 0 - 99 minutes in LE2	60 - 180 minutes
5.25A Power Supply DIP Switches SW1 / SW2	OFF / OFF OFF / ON ON / OFF ON / ON	ON / ON OFF / OFF
10.25A Power Supply DIP Switches SW1 / SW2	OFF / OFF OFF / ON ON / OFF ON / ON	OFF / ON
Enable / Disable Buzzer	Enable / Disable <i>Not settable in LE2</i>	Enable
Enable / Disable Ground Trouble	Enable / Disable <i>Not settable in LE2</i>	Enable
Set Buzzer Silence Access Level	1 or 2	2
First and Second Global Delay	0 - 10 minutes	0 minutes
Duct Detector Relay Delay	0 - 10 minutes	0 minutes
Contact Module Delay (All models)	0 - 180 seconds	0 seconds
Dual Relay Module Delay	0 - 10 minutes	0 minutes
Resound Alarm in Same Zone	Yes / No	This must be set to YES to comply with UL requirements, with limited exceptions as defined in UL 864, Section 46.3.2.
Alarm Verification	0-55 seconds	30-55 seconds
Pre-Signal	Enable / Disable	Enable / Disable
Positive Alarm Sequence (PAS)	Enable / Disable	Enable / Disable NOTE! PAS can be enabled and disabled in the User Access Level 2 menu.

Required Modules for Minimum Operation and Basic Function

Modules can be added, configured, and replaced without altering field wiring connections. This modularity allows each FireNET L@titude Fire Alarm Control Panel to be customized for a specific operation. Required modules for minimum operation of an addressable FireNET L@titude Fire Alarm Control Panel include:

- System A Panel Module
- System B Panel Module
- Dual Loop Panel Module

Minimum operation describes the FireNET L@titude Fire Alarm Control Panel as an operating fire control panel. All modules are field replaceable.

System A Panel Module (S769)

System A Panel Module provides essential functions on the FireNET L@titude Fire Alarm Control Panel. These functions include:

Functions	Description
NAC 1 and NAC 2	Class A or two Class B. Default Class B.
NAC 3 and NAC 4	Class A or two Class B. Default Class B.
PSU monitor	Battery disconnected, power failure, battery low, PSU ground trouble, charger trouble.
Power fail input	A connection of <2K to 0V will indicate a power fail
Ground trouble	A connection of 30K or less between a back board terminal (except volt-free terminals) and the ground will be indicated by a trouble.

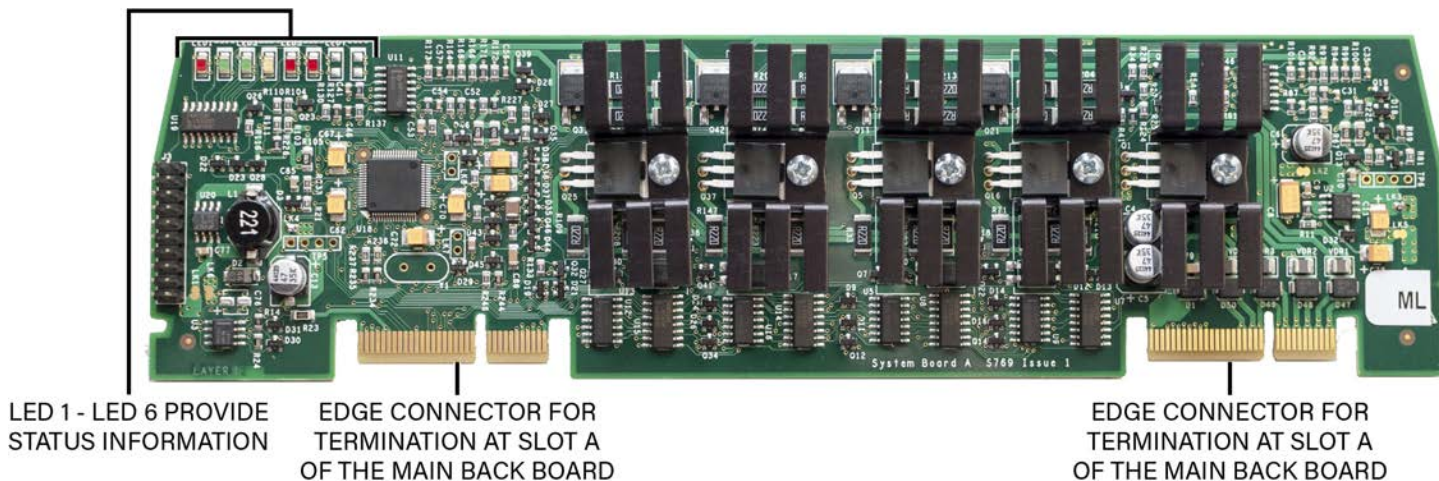

System A Panel Module fits into slot A of the Back Board and contains power supply monitoring, trouble monitoring, and four NAC circuits.

LED Label	Name	Color	Description
LED 1	Heartbeat	Red	Identifies functional status of System A Panel Module.
LED 2	Rx Comms	Green	A blinking green light indicates that the module is receiving data.
LED 3	Tx Comms	Green	A blinking green light indicates that the module is transmitting data.
LED 4	Trouble	Yellow	A flashing yellow identifies an error condition.
LED 5	Input Active LED	Red	Indicates that an input is active.
LED 6	Output Active LED	Red	Indicates that an output is active.

System B Panel Module (S770)

System B Panel Module monitors and controls essential input and output functions on the FireNET L@titude Fire Alarm Control Panel. The System B Panel Module includes the following input and output functions:

Input and Output Functions	Description
AUX 24 Output 1	24V DC output
AUX 24 Output 2	24V DC output
Fire Routing Output 2	0V output in standby, switches to 24V when activated, requires End-of-Line (EOL) diode
Fire Routing Input	Supervised input, requires 3.3K Ohm EOL resistor
Trouble Routing Output	24V output in standby, switches to 0V when activated, requires 3.3K Ohm EOL resistor
Trouble Routing Input	Supervised input, requires 3.3K Ohm EOL resistor
Prog Routing Output	Volt-free output measures 3.3K Ohms in standby, switches to 680 Ohms when activated
Prog Routing Input 1	Supervised input, requires 3.3K Ohm EOL resistor
Prog Routing Input 2	Supervised input, requires 3.3K Ohm EOL resistor
Fire Relay	Volt-free contact rated at 30V DC, 1A, Resistive
Trouble Relay	Volt-free contact rated at 30V DC, 1A, Resistive
Superv Relay	Volt-free contact rated at 30V DC, 1A, Resistive
Programmable Relay 1	Volt-free contact rated at 30V DC, 1A, Resistive
Programmable Relay 2	Volt-free contact rated at 30V DC, 1A, Resistive

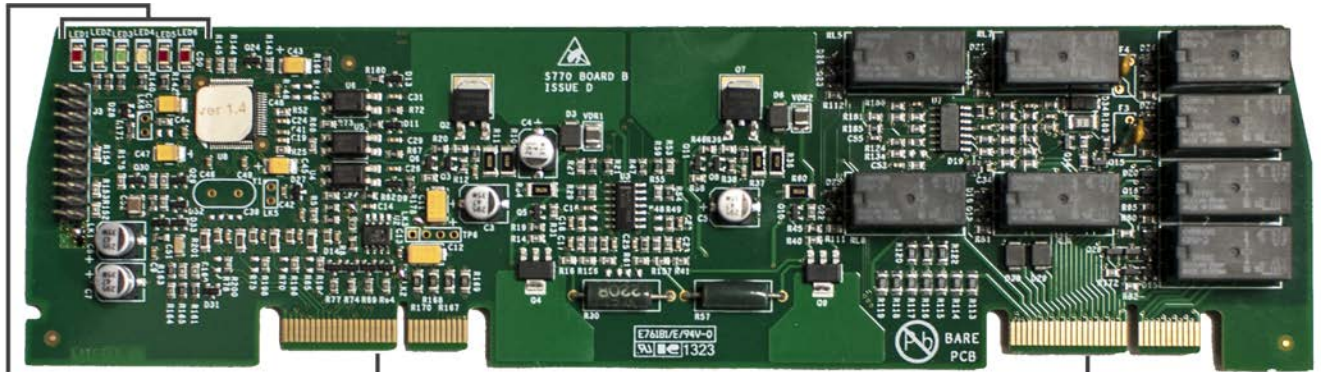

LED 1 - LED 6 PROVIDE STATUS INFORMATION

EDGE CONNECTOR FOR TERMINATION AT SLOT B OF THE MAIN BACK BOARD

EDGE CONNECTOR FOR TERMINATION AT SLOT B OF THE MAIN BACK BOARD

The System B Panel Module fits into slot B of the Main Back Board and controls the fire, trouble, and programmable relays, auxiliary 24 volt, fire routing, trouble routing, and programmable inputs and outputs. This figure illustrates System B Panel Module of the FireNET L@titude Fire Alarm Control Panel.

LED Label	Name	Color	Description
LED 1	Heartbeat	Red	Identifies functional status of System B Panel Module.
LED 2	Rx Comms	Green	A blinking green light indicates that the module is receiving data.
LED 3	Tx Comms	Green	A blinking green light indicates that the module is transmitting data.
LED 4	Trouble	Yellow	A blinking yellow light indicates that an error condition.
LED 5	Input Active LED	Red	Indicates that an input is active.
LED 6	Output Active LED	Red	Indicates that an output is active.

Dual Loop Panel Module (S758)

The Dual Loop Panel Module monitors loop device status and provides status to the panel processor. It holds device configurations and operates in a standalone manner when catastrophic failures occur. The Dual Loop Panel Module can be connected in any available slot (C-K) on the Main Back Board to provide this operating function.

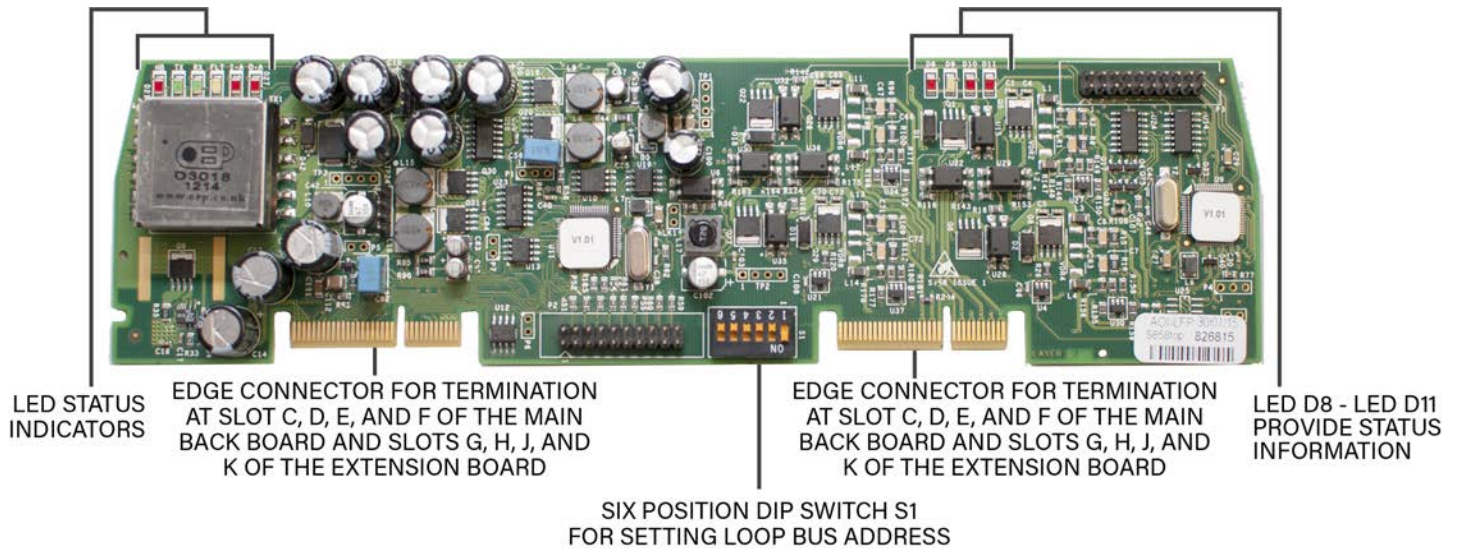

LED Label	Name	Color	Description
LED 1	Heartbeat	Red	Identifies functional status of Dual Loop Panel Module .
LED 2	Rx Comms	Green	A blinking green light indicates that the module is receiving data.
LED 3	Tx Comms	Green	A blinking green light indicates that the module is transmitting data.
LED 4	Trouble	Yellow	A blinking yellow light indicates that an error condition.
LED 5	Input Active LED	Red	Factory diagnostic / Reserved for future use.
LED 6	Output Active LED	Red	Factory diagnostic / Reserved for future use.
LED D8	Heartbeat for Processor 2	Red	A blinking red light flashes red to identify functional status of Processor 2.
LED D9	Trouble status for Processor 2	Yellow	A blinking yellow light flashes to identify the trouble status of Processor 2.
LED D10	Loop 1 State	Red	Factory diagnostic / Reserved for future use.
LED D11	Loop 2 State	Red	Factory diagnostic / Reserved for future use.

Notification Appliances

Notification Appliances operate with the FireNET L@titude Fire Alarm Control Panel in a special application or regulated mode. The panel supports the simultaneous operation of regulated and special application outputs between NACs.

The FireNET L@titude Fire Alarm Control Panel does not support the simultaneous operation of regulated and special application outputs on the same NAC channel.

The panel supports special application outputs when operating:

- Gentex NAC devices
- System Sensor NAC devices
- Wheelock NAC devices
- Amseco NAC devices

Synchronization modules are not required and should not be used on special application outputs.

Synchronization

NAC synchronization can be performed across all NAC channels of an individual panel. NAC synchronization cannot be performed across multiple panels.

The FireNET L@titude Fire Alarm Control Panel provides internal device synchronization between the outputs of NACs when operating NAC devices from Gentex, Amseco, System Sensor, or Wheelock without the use of an external synchronization module. External synchronization modules must not be used on the NAC outputs when operating in the synchronization mode.

While most systems only use one device manufacturer, the L@titude panel can synchronize strobe devices from any two manufacturers simultaneously. Devices from different manufacturers cannot be combined on the same channel. Audible synchronization across manufacturers can only be accomplished between Gentex and System Sensor.

The maximum number of strobes that can be synchronized for each brand is

- Amseco $2.37A / 88mA = 27$ appliances
- Gentex $2.5A / 78mA = 32$ appliances
- System Sensor $1.32A / 66mA = 20$ appliances
- Wheelock $2.5A / 60mA = 41$ appliances

Configuring NAC Outputs

Settings are provided in the panel GUI and Loop Explorer 2 for controlling the NAC outputs of the FireNET L@titude Fire Alarm Control Panel. Selections are available in these utilities for providing outputs with synchronization or various forms of constant power. Settings are also provided to allow the Alarm Silence button to operate on the front panel in various modes.

Review the settings described below to configure each NAC output for operation.

Output Options	General Alarm and Emergency are selected as default conditions. Alternative output options for this field include Auxiliary Output, Pre-Alarm Output, Supervisory Alarm, and Trouble. Do not select the General Alarm option if the NAC channel is to be controlled by cause-and-effect programming.
Strobe	Strobe Output is not selected for operation as a default condition. Selecting this field allows the user to define which synchronization protocol to be used.
NAC AUX 24V DC	When the Strobe option above is not selected, Off is selected as the default operating condition. Options for this output are continuous constant power, door holder, and resettable. <ul style="list-style-type: none"> • Continuous constant power provides a voltage output comparable to AUX 24V. • Door holder outputs lose power during fire alarm conditions and/or during AC power loss. • Resettable causes power loss that lasts 4-5 seconds each time the panel is reset.
Alarm Silence	Each NAC is configurable in reaction to the Alarm Silence button on the front panel. Edit properties of the NAC channel in Loop Explorer 2. Select the box for Silencing if NAC silencing is required on this channel. If Internal Synchronization Protocols are in use, an option is also available to Silence the strobe. Failure to check the Strobe Silence box will cause horns to be silenced with continued operation of the strobe.

For more details, refer to [NAC Output Specifications](#).

Optional Modules and Assemblies

Optional modules of the FireNET L@titude Fire Alarm Control Panel are available for zone alarm indications and networking. Modules providing these functions include the:

- [Network Module](#)
- [Dual Loop Panel Module](#)
- [Printer](#)
- [Zone LED Module](#)
- [16 Channel I/O Interface Card](#)
- [16 Channel I/O Panel Module](#)
- [L@titude Network Vision Annunciator](#)
- [Media Gateway™ Panel Module](#)
- [8 Channel Relay Panel Module](#)
- [8 Channel Conventional Zone Panel Module](#)
- [4 Channel NAC Panel Module](#)

Network Module (S723)

The L@titude Network Module (S723) provides supervised, enhanced high-speed communication for networking up to a maximum of 127 fire control panels. The network provided by this module can support combinations of FireNET L@titude Fire Alarm Control Panels and L@titude Vision Annunciators .

FireNET L@titude Fire Alarm Control Panels can receive events from other panels in the network. The Class X networking used in conjunction with the Network Module provides tolerance against open and short circuit trouble conditions.

The L@titude Network Module can be configured to operate in a "bridge mode", which enables the FireNET L@titude Fire Alarm Control Panel to operate on a network with FireNET and FireNET Plus panels. The FireNET and FireNET Plus network can support up to 64 fire control panels, and has other limitations, such as more limited text-field lengths, zones, C&E relationships, etc.

For more information about the L@titude Network Module , refer to the **L@titude Network Module Information Guide (MAN-1436HA)**.



Printer (S768)

The L@titude Printer is an optional feature for printing fire system events as they occur. The printer is located on the fascia, below the Zone LEDs (if present). It is a thermal printer and never requires replacement ink. Printing is performed on heat-sensitive paper rolls. A trouble message is reported when the paper runs out. The printer includes a front loading feature for replacing paper rolls. Refer to Equipment List for the part number and description of the paper roll replacement.

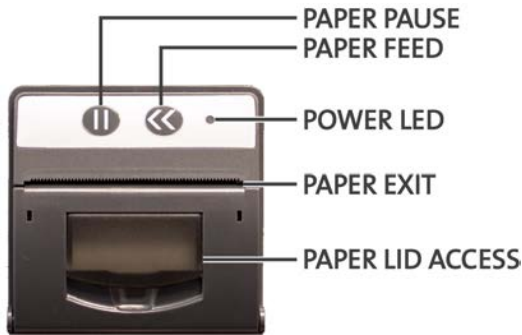

To load paper rolls in the printer:

1. Lift the latch on the face of the printer to access the paper chamber.
2. Load the paper in the paper chamber with the paper edge exiting from the top and with the shiny-side facing the top of the fire control panel.
3. When the LED indicator is on and the printer is not in standby, you can press the << button on the face of the printer to test feed the paper.

When using a printer with a FireNET L@titude Fire Alarm Control Panel fitted with a Plex-Door, the paper may adhere to the door because of the static generated when removing the protective film. To combat this, wipe the surface of the door with a slightly damp, soapy cloth before the first use.

Zone LED Module (S771)

The Zone LED module contains 48 LEDs and is connected to the LCD Main Processor Board of the FireNET L@titude Fire Alarm Control Panel. A maximum of three Zone LED modules can be connected to provide the fascia with 144 Zone LED indicators. The following figure illustrates the component-side of the Zone LED Module:

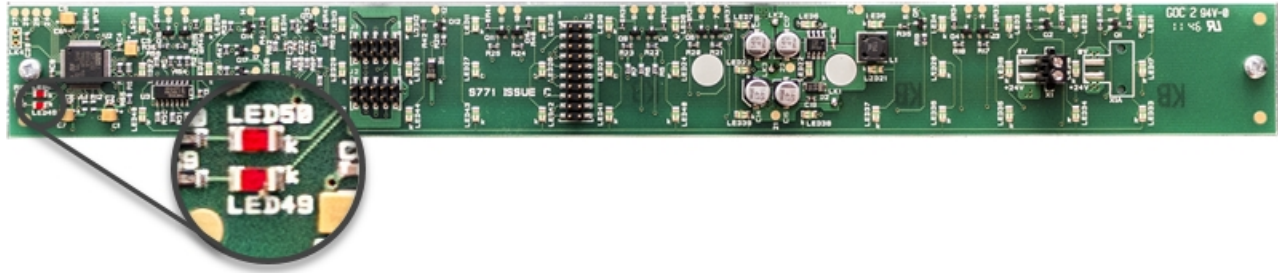

The component side of the Zone LED module is visible when the cabinet door is open. Zone LED indicators are not present on the component-side of the Zone LED module. The opposite side of the image shown contains Zone LED indicators.

LED Number	Description
LED 49	Flashes red to identify receiving data.
LED 50	Flashes red to identify functional status of the Zone LED module.

16 Channel I/O Interface Card (S560)

The 16 Channel I/O Interface enhances the versatility of the alarm system by providing additional input and output capabilities to the FireNET L@titude Fire Alarm Control Panel. Inputs and outputs can be selected for up to 16 individual channels. All inputs and outputs are configured in the same way as devices connected to addressable loops of the panel. The 16 Channel I/O Interface can be configured to contribute or act upon cause and effect logic.

Use Case Examples

The 16 Channel I/O Interface can be used to interface the L@titude panel to a NAC extender or Voice Evacuation system, by providing

- inputs to the L@titude panel for dry contact closures such as General Trouble, AC Power Trouble, or Battery Trouble from these devices.
- outputs from the panel to control various NAC or Voice Evacuation outputs.

The 16 Channel I/O Interface can be used to interface the L@titude panel to a secondary panel or releasing panel, by providing

- inputs to the L@titude panel for dry contact closures such as Fire, Supervisory, and Trouble from these panels, and various stages of release from the releasing panel.
- outputs from the panel to activate NAC outputs on these panels.

Restrictions

Inputs are intended for use as control signals from other life safety equipment. Inputs of this device are not supervised, and therefore cannot be used directly as initiating circuits for life safety applications within a UL listed system. Outputs are intended for use as control signals to other life safety equipment. Outputs of this device are not supervised, and cannot be directly connected to notification or releasing-type appliances in a UL listed system.

In a UL listed system, the 16 Channel I/O Interface:

- must be housed in a separately-listed enclosure.
- must be located in the same room as the L@titude panel.
- must be located in the same room as the equipment being interfaced.
- must be wired in conduit (or equivalently protected against mechanical injury) and within 20 feet of equipment being interfaced.
- must not be used to control the release of extinguishants.

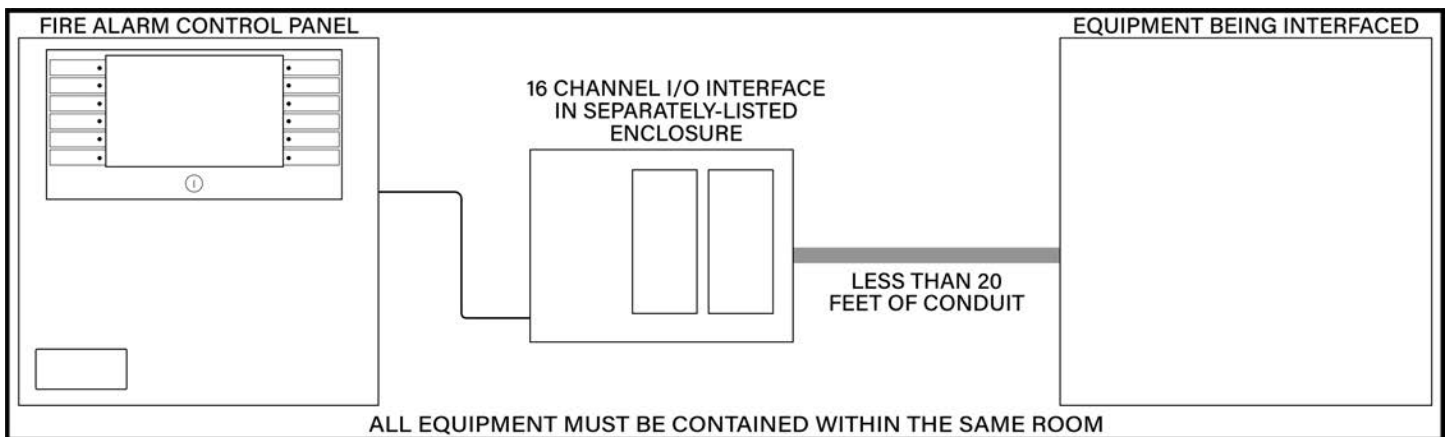

For more information about the 16 Channel I/O Interface, refer to the 16 Channel I/O Interface Information Guide (MAN-1438HA).

16 Channel I/O Panel Module (S772)

The 16 Channel I/O Interface enhances the versatility of the alarm system by providing additional input and output capabilities to the FireNET L@titude Fire Alarm Control Panel. Inputs and outputs can be selected for up to 16 individual channels. All inputs and outputs are configured in the same way as devices connected to addressable loops of the panel. The 16 Channel I/O Interface can be configured to contribute or act upon cause and effect logic.

Use Case Examples

The 16 Channel I/O Interface can be used to interface the L@titude panel to a NAC extender or Voice Evacuation system, by providing

- inputs to the L@titude panel for dry contact closures such as General Trouble, AC Power Trouble, or Battery Trouble from these devices.
- outputs from the panel to control various NAC or Voice Evacuation outputs.

The 16 Channel I/O Interface can be used to interface the L@titude panel to a secondary panel or releasing panel, by providing

- inputs to the L@titude panel for dry contact closures such as Fire, Supervisory, and Trouble from these panels, and various stages of release from the releasing panel.
- outputs from the panel to activate NAC outputs on these panels.

Restrictions

Inputs are intended for use as control signals from other life safety equipment. Inputs of this device are not supervised, and therefore cannot be used directly as initiating circuits for life safety applications within a UL listed system. Outputs are intended for use as control signals to other life safety equipment. Outputs of this device are not supervised, and cannot be directly connected to notification or releasing-type appliances in a UL listed system.

In a UL listed system, the 16 Channel I/O Panel Module:

- must be wired in conduit (or equivalently protected against mechanical injury) and within 20 feet of equipment being interfaced.
- must not be used to control the release of extinguishants.

For more information about the 16 Channel I/O Panel Module, refer to the 16 Channel I/O Panel Module Information Guide (MAN-1420HA).

L@titude Network Vision Annunciator (S787)



L@titude Network Vision Annunciator

LFC00NC-10 (Red), LFC00NC-40 (Gray), LFC00NC-60 (Black)

The L@titude Network Vision Annunciator is a display and control unit which duplicates the indications and primary controls of FireNET L@titude Fire Alarm Control Panels connected to the same network. The Annunciator connects via the network interface, and any number of repeaters can be connected up to the maximum number of nodes allowed by the network.

L@titude Network Vision Annunciators can be configured to replicate fire control panel functionality or to operate as simple, display-only devices for applications where access to fire alarm controls are inappropriate. The Annunciator can be configured to display events from any combination of nodes on the network.

For more information about the L@titude Network Vision Annunciator , refer to the **L@titude Network Vision Annunciator Information Guide (MAN-1434HA)**.

Media Gateway™ Panel Module (S788)

The Media Gateway™ is a communication panel module for the FireNET L@titude Fire Alarm Control Panel. It provides connectivity to a remote monitoring center via Sur-Gard Fibro or dial-up. SIA is the recommended format for usage, but Contact ID is also supported. Transmission can be made through one or two telephone lines, and/or IP through Ethernet. Standard reporting codes have been pre-defined, although the user may customize these codes through the Loop Explorer 2 programming application.

For more information about the Media Gateway Panel Module, refer to the **Media Gateway Panel Module Information Guide (MAN-1439HA)**.

8 Channel Relay Panel Module (S791)

The 8 Channel Relay Panel Module has 8 voltage-free, unsupervised SPST Normally-Open relay contacts, each of which can be individually programmed. All outputs are configurable in the same way as devices connected to the loops and all may be acted upon by cause and effect logic.

Use Case Examples

The 8 Channel Relay Panel Module are typically used in applications which require more than the four standard relay outputs, such as signaling to other systems or plant control.

This module can be used to interface the L@titude panel to a NAC extender or Voice Evacuation system, by providing

- outputs from the panel to control various NAC or Voice Evacuation outputs.

This module can be used to interface the L@titude panel to a secondary panel or releasing panel, by providing

- outputs from the panel to activate NAC outputs on these panels.

For more information about the 8 Channel Relay Panel Module, refer to the **8 Channel Relay Panel Module Information Guide (MAN-1440HA)**.

8 Channel Conventional Zone Panel Module (S792)

The 8 Channel Conventional Zone Panel Module has 8 supervised detection circuits (Class B). If Class A circuits are needed, they can be made from Class B circuit pairs (1 & 2, 3 & 4, 5 & 6, 7 & 8). Each circuit, regardless of class, can support up to 20 conventional detectors and approved devices. Individual circuits may be configured for trigger resistor or short circuit activation. These circuits may be used for any of the standard input actions and can be configured to contribute to cause and effect logic.

For more information about the 8 Channel Conventional Zone Panel Module, refer to the **8 Channel Conventional Zone Panel Module Information Guide (MAN-1441HA)**.

4 Channel NAC Panel Module (S793)

The 4 Channel NAC panel modules are typically used in applications that require more than the standard panel NAC outputs. Each of these modules adds 4 additional supervised NAC outputs, each of which can be individually programmed.

These modules may be mixed with 16 Channel I/O modules, 8 Channel Conventional Zone modules, or 8 Channel Relay modules to provide a very flexible system of I/O to satisfy almost any requirement. All inputs and outputs are configurable in the same way as devices connected to the loops and all may contribute to, or be acted upon, by cause and effect logic.

For more information about the 4 Channel NAC Panel Module, refer to the **4 Channel NAC Panel Module Information Guide (MAN-1442HA)**.

Batteries

Batteries are used as a secondary power source for the FireNET L@titude Fire Alarm Control Panel, in the event that the primary power source (AC) fails.

Required standby battery capacity is dependent on the required standby period and load of the FireNET L@titude Fire Alarm Control Panel system. Determine the current consumption of the fire alarm system for alarm and standby conditions. Use these maximum current values to determine the minimum required battery capacity of the fire alarm system.

Perform the installation only after calculations have been completed and a suitable battery capacity determined. Refer to Calculations or Loop Explorer 2 to determine the minimum required standby battery capacity of the system.

Standby Battery Type

The FireNET L@titude Fire Alarm Control Panel is a 24 volt system designed to use Valve Regulated Lead Acid (VRLA) batteries as a secondary (backup) power source. VRLA batteries are not commonly available in 24V, so two 12V batteries are typically used, wired in series.

FASCIA

This section describes the features (standard and optional) of the FireNET L@titude Fire Alarm Control Panel that are located on the fascia.

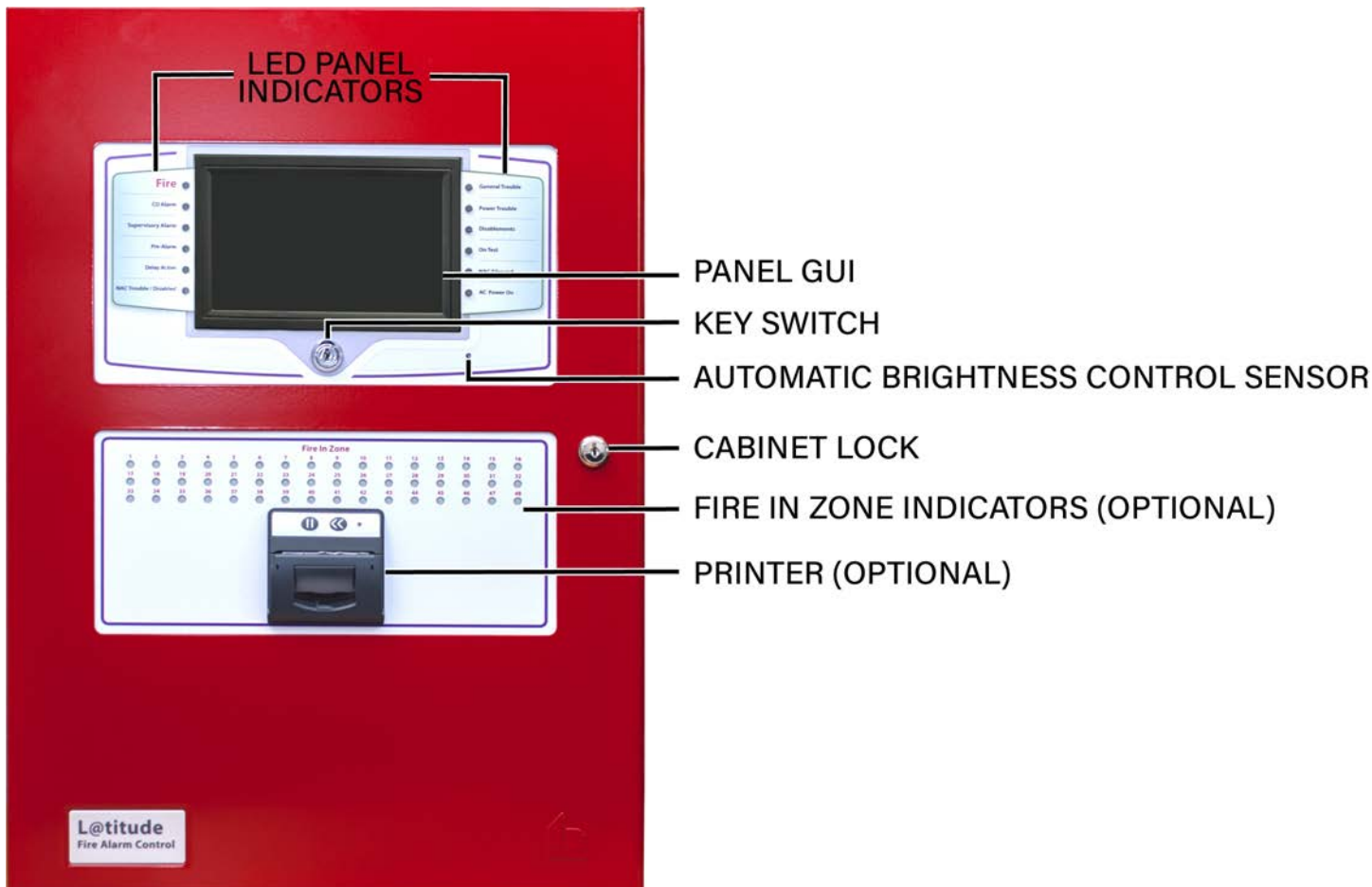













LED Panel Indicators	Refer to LED Status Indicators below for details.
Panel GUI	The 7 inch, full-color, high-resolution panel GUI provides a resistive touchscreen that allows operation when users are wearing gloves.
Key Switch	The key switch on the FireNET L@titude Fire Alarm Control Panel provides level 2 access to the panel, which allows the user to silence alarms and reset the system. These functions can also be accessed by using a 6-digit access level 2 code.
Cabinet Lock	This provides access to panel electronics. Some models of the FireNET L@titude Fire Alarm Control Panel place all user controls behind glass. In these models, the cabinet lock provides access to all controls, including access level 2 controls.
Fire In Zone Indicators (Optional)	Refer to Fire In Zone Indicators below for details.

Printer (Optional) The L@titude Printer is an optional feature located on the lower portion of the fascia. It is a thermal printer that never requires replacement ink and uses thermal paper rolls accessible from the fascia.

LED Status Indicators

Panel LEDs

For complete information about each event type, refer to Events and Status.

Fire 	A fire alarm or fire drill condition exists.
CO Alarm 	A CO alarm condition exists.
Supervisory Alarm 	A supervisory condition exists.
Pre-Alarm 	A pre-alarm condition exists.
Delay Active 	Output(s) are delayed from activating.
NAC Trouble / Disabled 	A trouble exists on one of the NACs OR Connections at this location are faulty or disabled.
 General Trouble	A General Trouble condition exists. Other LEDs may be illuminated that identify the nature of the trouble.
 Power Trouble	A power-related trouble condition exists.
 Disabling	One or more devices are intentionally disabled.
 On Test	Some or all of the fire system is in a test mode.
 NAC Silenced	The NAC silence feature is activated.
 AC Power On	AC power is on. In the FIRE SYSTEM NORMAL status, this LED is illuminated and all other LEDs are off.

Fire In Zone Indicators

Fire In Zone indicators are an optional feature provided on the fascia of the FireNET L@titude Fire Alarm Control Panel in single, double, or triple bank configurations. The following figure illustrates a single bank of 48 Fire In Zone indicators:



Single bank configurations contain 48 Fire In Zone indicators. Two bank configurations contain 96 Fire In Zone indicators, and three bank configurations contain 144 Fire In Zone indicators.

MAIN BACK BOARD (S722)

The Main Back Board of the FireNET L@titude Fire Alarm Control Panel provides slots for required and optional panel modules, as well as for field wiring and power supply terminations.

Minimum functions of the FireNET L@titude Fire Alarm Control Panel are provided when Slot A of the Main Back Board contains System A Panel Module, Slot B contains System B Panel Module, and Slots C, D, E, or F contain a Dual Loop Panel Module. Two addressable loops are provided by the Dual Loop Panel Module in this configuration. The following figure illustrates the Main Back Board and the Power Supply of the cabinet box:

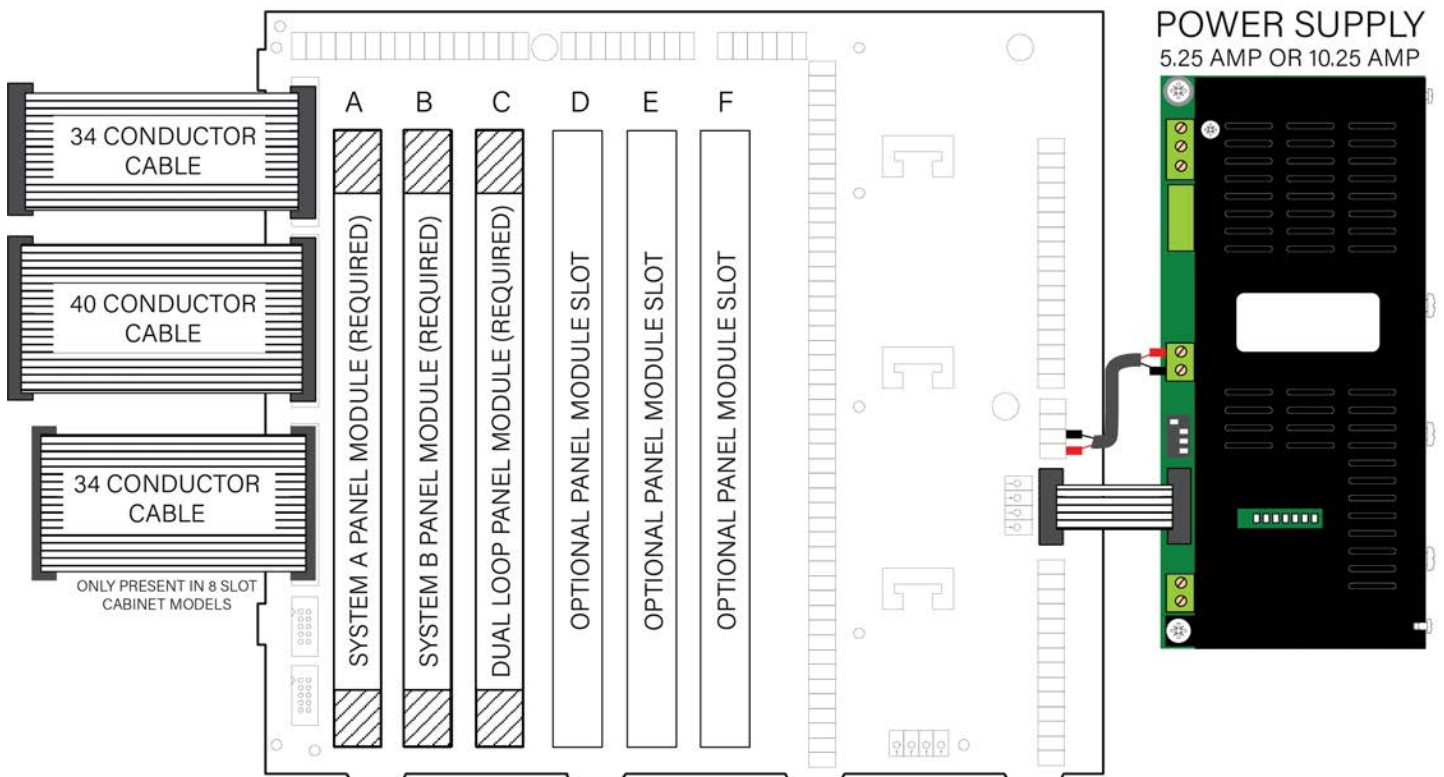

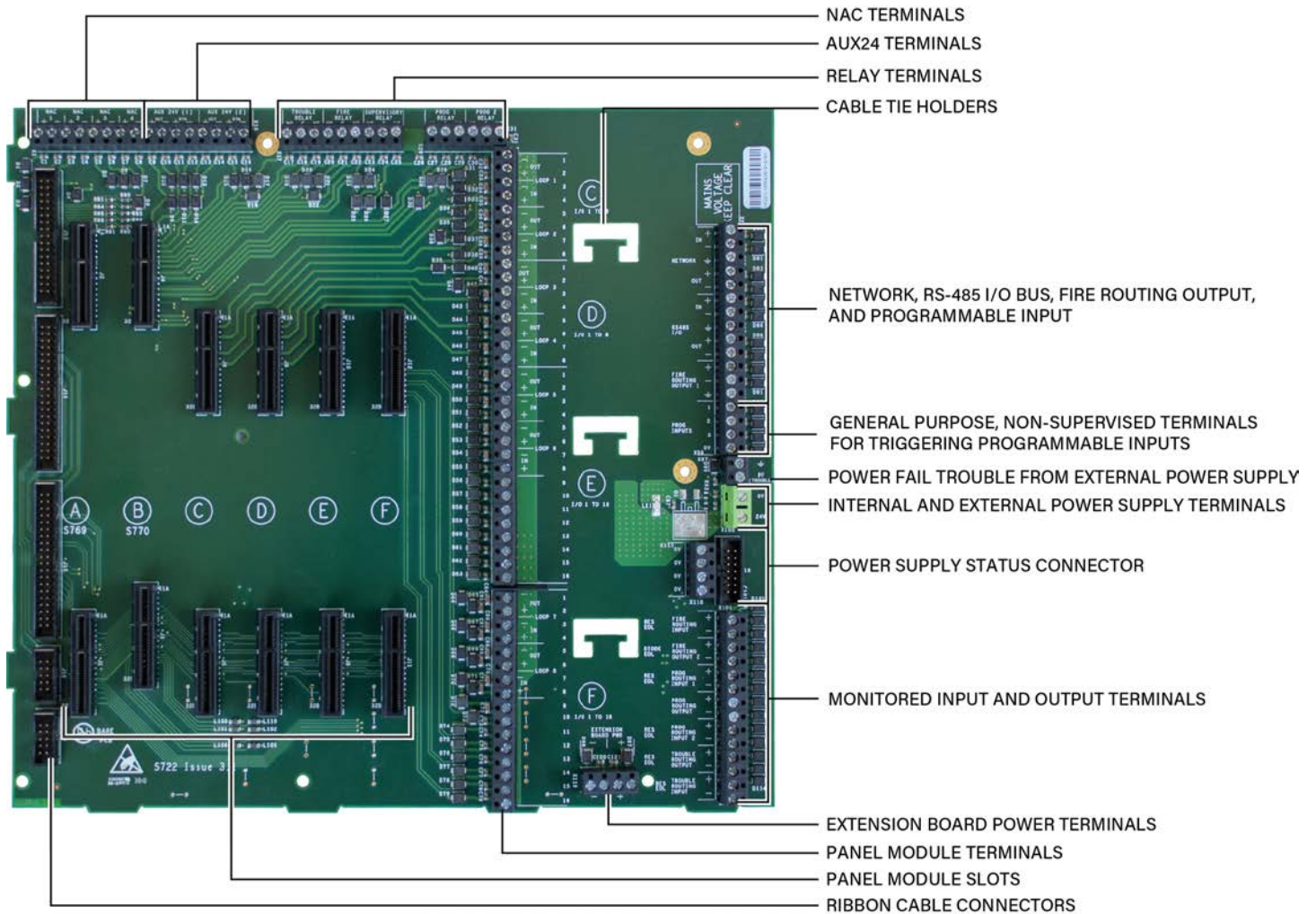

The Main Back Board contains connector slots A through F. Operation of the FireNET L@titude Fire Alarm Control Panel requires that one Dual Loop Panel Module is connected in slots C, D, E, or F to meet minimum operating requirements.

The Dual Loop Panel Module can be connected in slots C, D, E, or F of the Main Back Board. Slot C of the Main Back Board is the factory location for the Dual Loop Panel Module connection.

NAC and AUX 24V Terminals

NAC terminals 1 to 4 provide 24 VDC @ 2.5 A. In the default state, these circuits can be connected as four Class B supervised outputs. However, they can be configured as two Class A or two Class B and one Class A output. Power limited circuits should be routed separately from non-power limited circuits. The following figure illustrates the NAC and AUX 24V terminals of the Main Back Board:

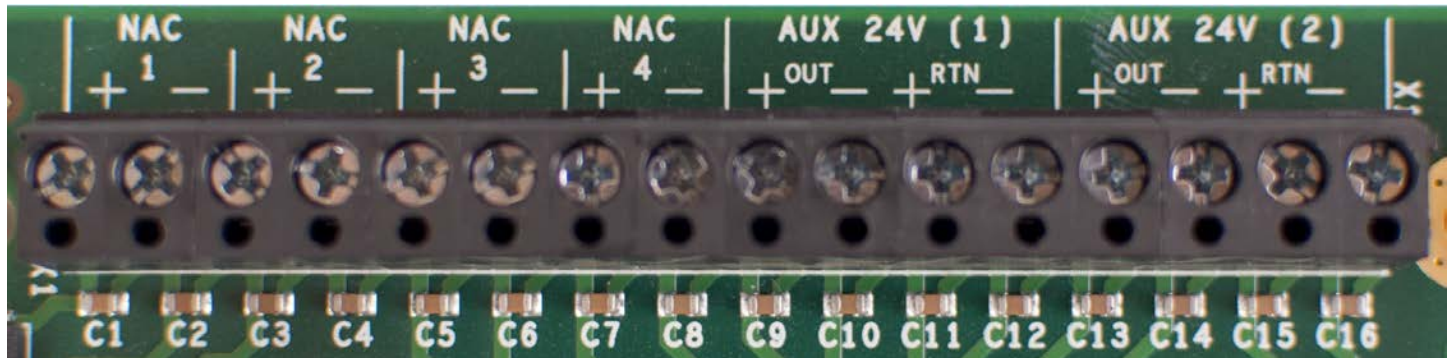

Field Terminals	Designation	Supervision	Power Limited
(+) and (-)	NAC 1	using EOL diode	Yes
(+) and (-)	NAC 2	using EOL diode	Yes
(+) and (-)	NAC 3	using EOL diode	Yes
(+) and (-)	NAC 4	using EOL diode	Yes
OUT (+) and (-) RTN (+) and (-)	AUX 24V (1)	Supervision by connecting the end of the cable back to the RTN	Yes
OUT (+) and (-) RTN (+) and (-)	AUX 24V (2)	Supervision by connecting the end of the cable back to the RTN	Yes

Terminals

The default designation is as shown below, however all 5 relays are user-configurable.

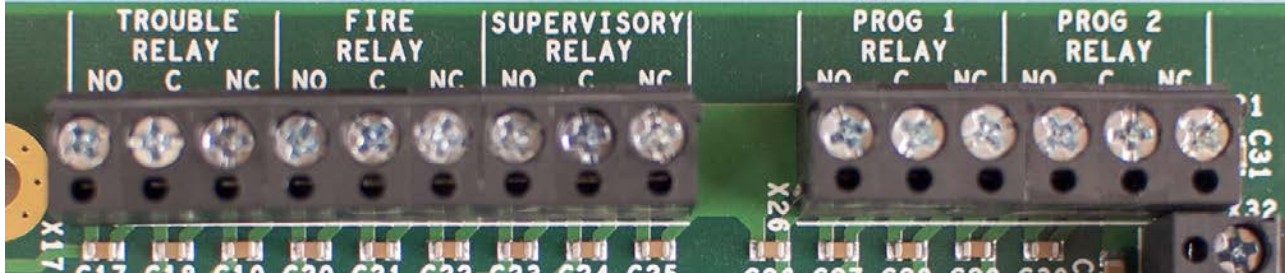

Field Terminals	Default Operation	Default Setting
NO, C, and NC	TROUBLE RELAY	Trouble
NO, C, and NC	FIRE RELAY	Fire
NO, C, and NC	SUPERV RELAY	Supervisory
NO, C, and NC	PROG 1 RELAY	Transparent
NO, C, and NC	PROG 2 RELAY	Transparent

Panel Module Slots

The following figure illustrates the Panel Module Slots of the Main Back Board:

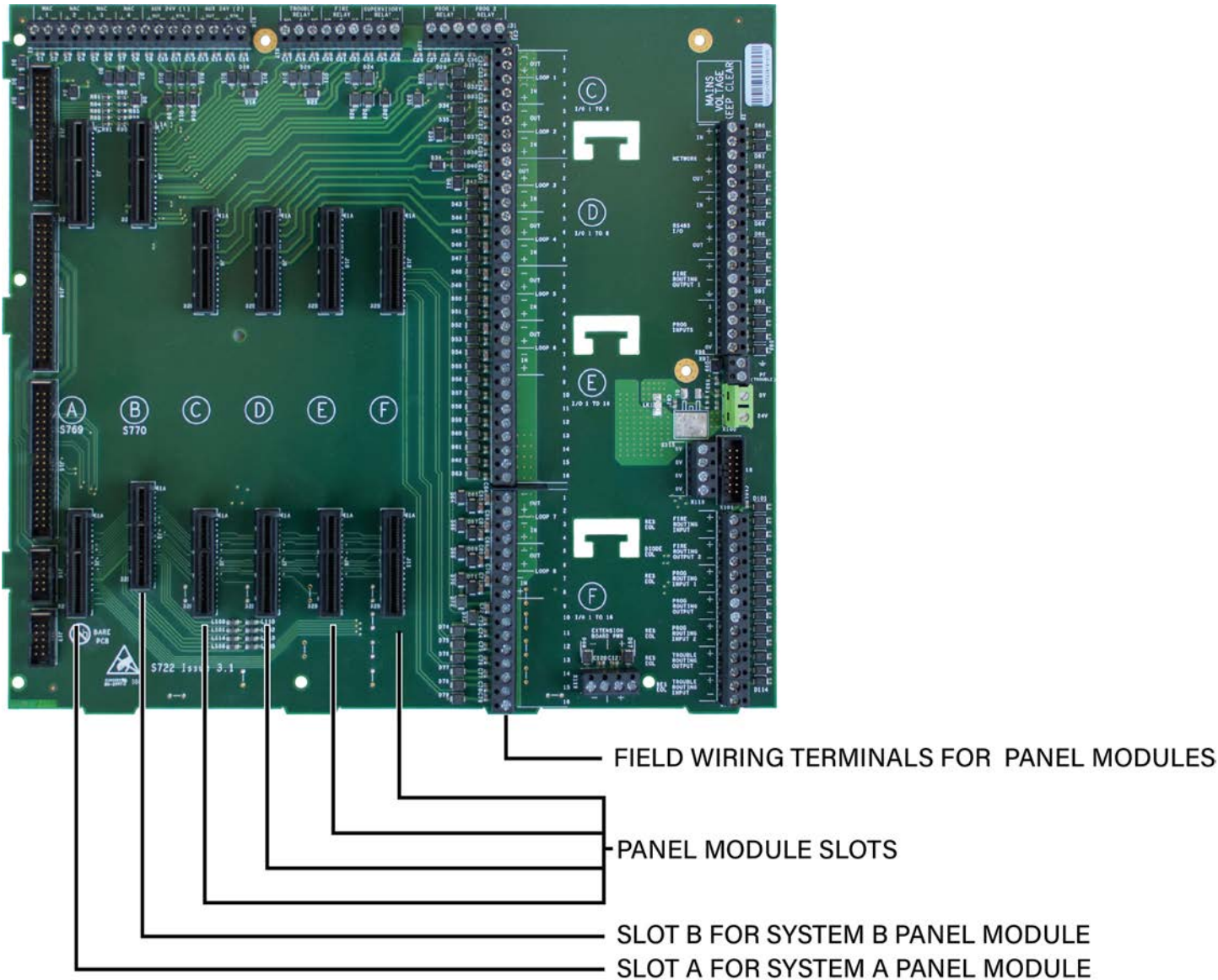

Field Terminal Assignments

Panel module slot positions on the Main Back Board correspond to specific field terminal locations on the Main Back Board.

Slot	Field Terminal Location
C	Addressable Loops 1 and 2 or 4 Channel NAC
D	Addressable Loops 3 and 4 or 4 Channel NAC
E	Addressable Loops 5 and 6 or 4 Channel NAC, 16 Channel I/O, 8 Channel Relay, or 8 Channel Conventional Zone.
F	Addressable Loops 7 and 8 or 4 Channel NAC, 16 Channel I/O, 8 Channel Relay, 8 Channel Conventional Zone, or Media Gateway

Slots A and B do not contain corresponding lettering on field terminals of the Main Back Board. These slots are dedicated system boards that operate primary functions. System A Panel Module must connect to slot position A on the Main Back Board and System B Panel Module must connect to slot position B on the Main Back Board.

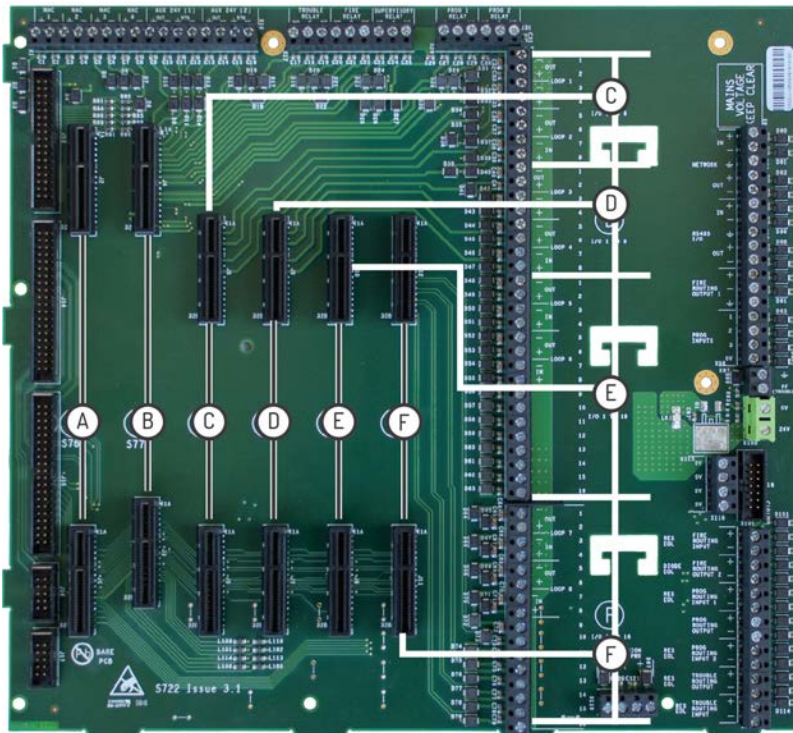

Panel Module Slots

Board Slot C

The following figure illustrates the Board Slot C terminals of loops 1 and 2:

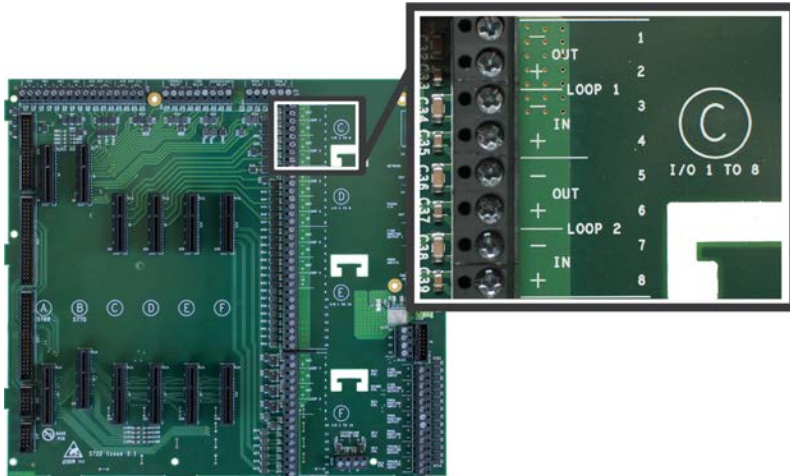

Field Terminals	Board Location	Possible Panel Modules	Function
1-8	Slot C	Dual Loop Panel Module (pre-installed)	Loop 1 and Loop 2

Board Slot D

The following figure illustrates the Board Slot D terminals of loops 3 and 4:

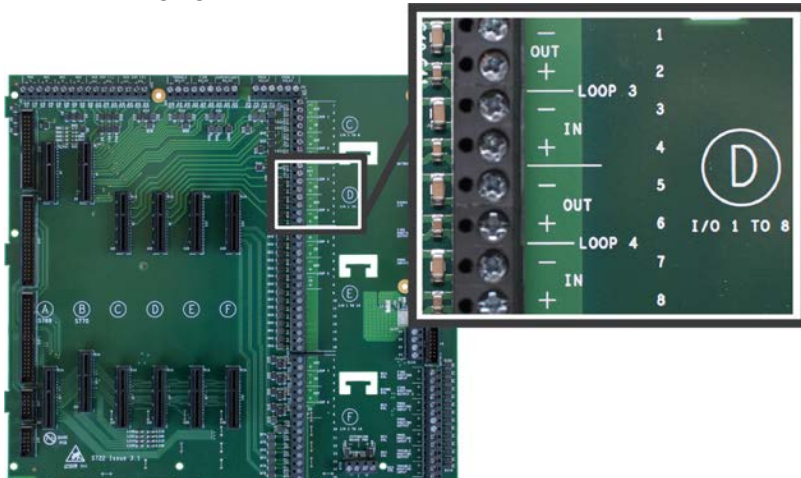

Field Terminals	Board Location	Possible Panel Modules	Function
1-8	Slot D	Dual Loop Panel Module	SLC In / Out
1-8	Slot D	4 Channel NAC Panel	NAC Outputs

Field Terminals	Board Location	Possible Panel Modules	Function
-----------------	----------------	------------------------	----------

Module

Board Slot E

The following figure illustrates the Board Slot E terminals of loops 5 and 6:

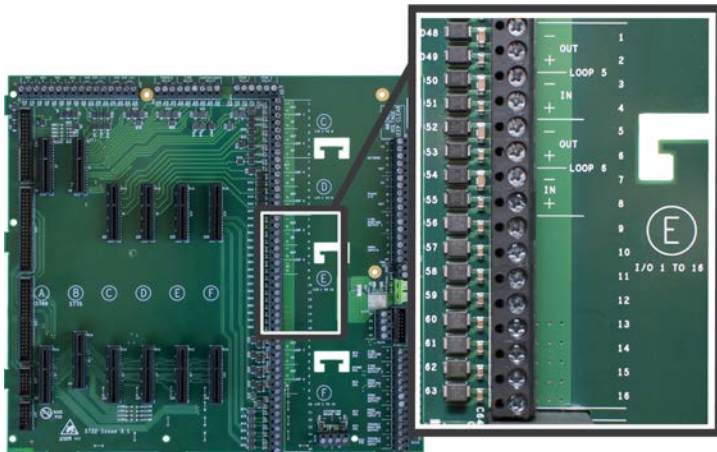

Field Terminals	Board Location	Possible Panel Modules	No. of Circuits	Function
1-8 (9-16 not used)	Slot E	Dual Loop Panel Module	2	SLC In / Out
1-8 (9-16 not used)	Slot E	4 Channel NAC Panel Module	4	NAC Outputs
1-16	Slot E	8 Channel Relay Panel Module	8	Form A Dry Contacts
1-16	Slot E	8 Channel Conventional Zone Panel Module	8	Two-wire Initiating Device Circuits (IDC)
1-16	Slot E	16 Channel I/O Panel Module	16	Input / Output Circuits

Board Slot F

The following figure illustrates the Board Slot F terminals of Loops 7 and 8:

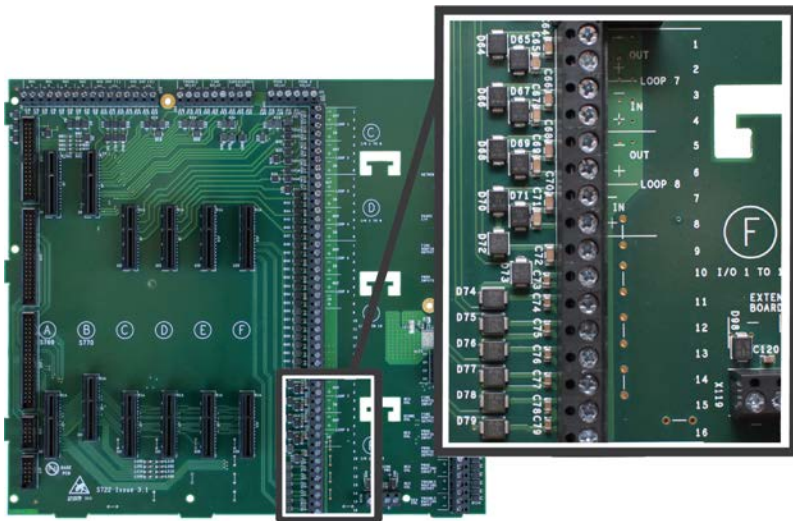

If you have, or plan to obtain, a Media Gateway Panel Module, it must be installed into Board Slot F.

Field Terminals	Board Location	Possible Panel Modules	No. of Circuits	Function
1-8 (9-16 not used)	Slot F	Dual Loop Panel Module	2	SLC In / Out
1-8 (9-16 not used)	Slot F	4 Channel NAC Panel Module	4	NAC Outputs
1-16	Slot F	8 Channel Relay Panel Module	8	Form A Dry Contacts
1-16	Slot F	8 Channel Conventional Zone Panel Module	8	Two-wire Initiating Device Circuits (IDC)
1-16	Slot F	16 Channel I/O Panel Module	16	Input / Output Circuits
1-16	Slot F	Media Gateway Panel Module	N/A	External Communication

Extension Board Power Terminals

This figure illustrates Extension Board Power Terminals of the Main Back Board. These terminals are non-power limited.

Field Terminals	Description
(-)	Two terminals for providing 0 VDC return-power (-).
(+)	Two terminals for providing 24 VDC power (+).

These terminals are used for factory wiring purposes only.

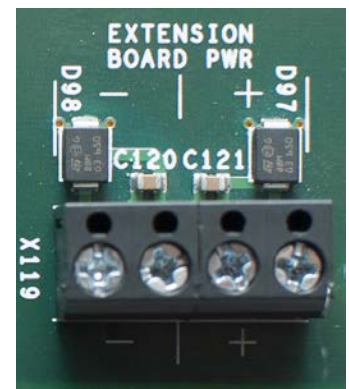

Network, RS-485 I/O, Fire Routing Output 1, and Prog Input

The following figure illustrates Network, RS-485 I/O, Fire Routing Output 1, and Prog Input of the Main Back Board:

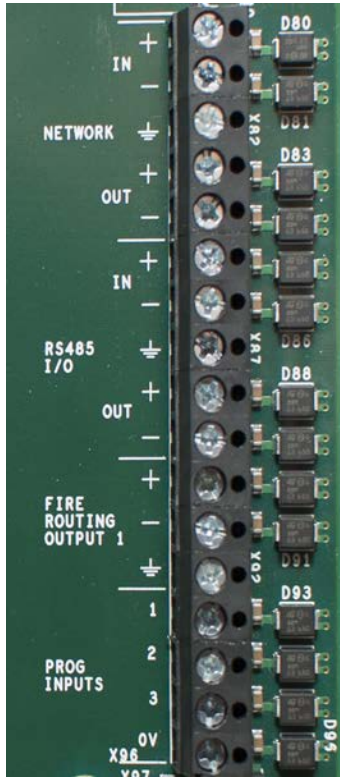

Field Terminals	Description
NETWORK	Provides Class X connections for intra-panel and annunciator networking.
RS-485 I/O	Provides ancillary RS-485 connections for external modules.
FIRE ROUTING OUTPUT 1	Not used. Reserved for future use.
PROG INPUTS	Provides three programmable inputs that operate on active low thresholds.

Power Supply Terminals

Power Supply Terminals of the Main Back Board are used for factory wiring purposes only.

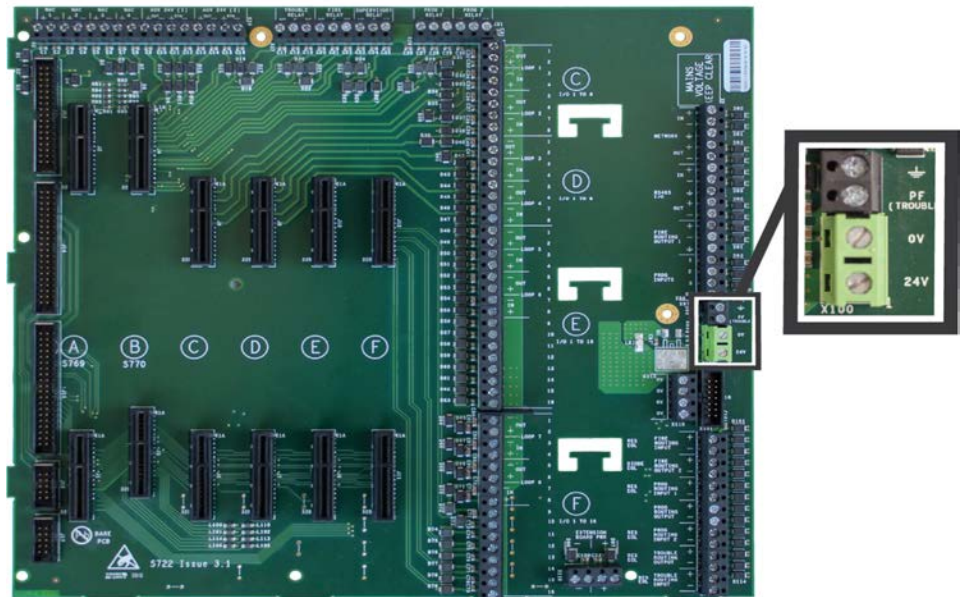

Field Terminals	Description	Power Limited
	Ground terminal connection	N/A
TRBL	Power trouble input. Active when connected to negative terminal (-).	Yes
(-)	Negative terminal connection from the 24V DC power supply	Non-power limited
(+)	Positive terminal connection from the 24V DC power supply	Non-power limited

0V Terminals

This figure illustrates 0V terminals of the Main Back Board. These terminals provide general purpose 0V and are non-power limited.

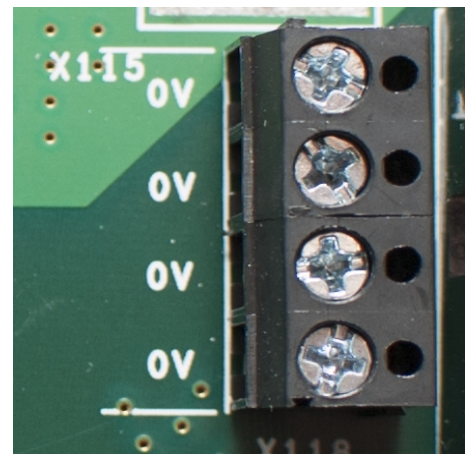

Power Supply Trouble Signaling Connector

The following figure illustrates the Power Supply Trouble Signaling Connector of the Main Back Board. This terminal provides power and trouble signaling from the power supply.

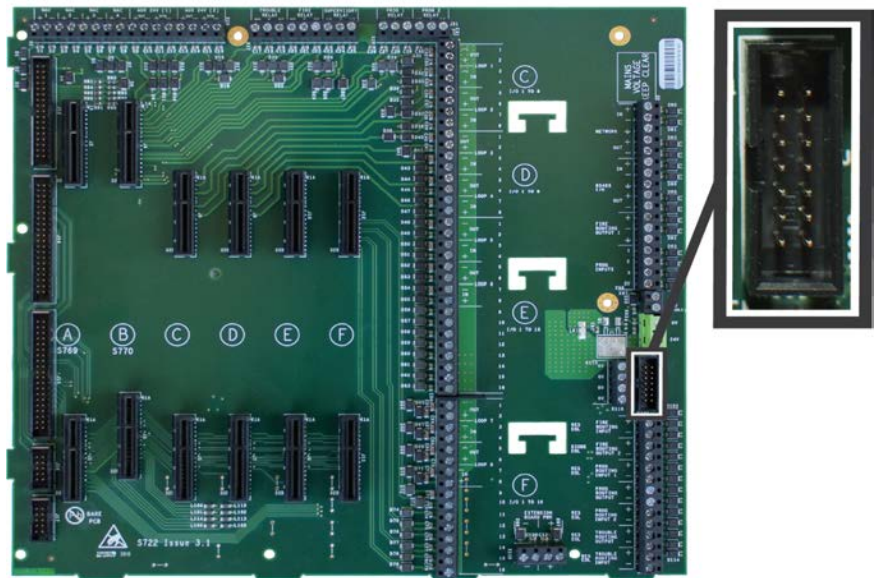

Supervised Input and Output Terminals

Fire and Trouble routing outputs provide supervised, 24V DC voltage with reversing outputs. Refer to [Main Back Board Specifications](#) for detailed information about these terminals.

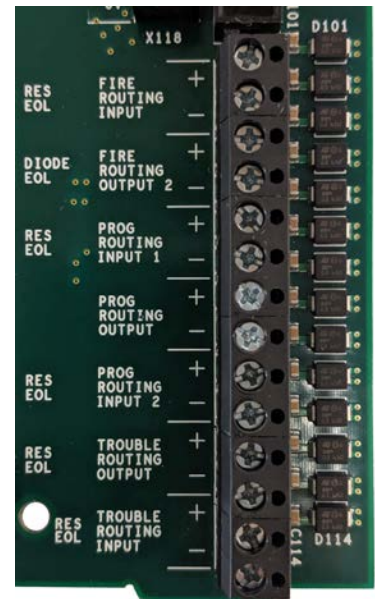

EXTENSION BOARD (S786)

Eight slot cabinet models include an extension board. This provides connections for 4 additional modules to be used with the FireNET L@titude Fire Alarm Control Panel. In this type of configuration, the extension board is installed to the right of the Main Back Board on the backplate.

WARNING! Separate high and low voltage wiring in the enclosure with a minimum gap of 0.25". AC power lines should be routed through a dedicated conduit.

Refer to the following illustration when wiring the Extension Board.

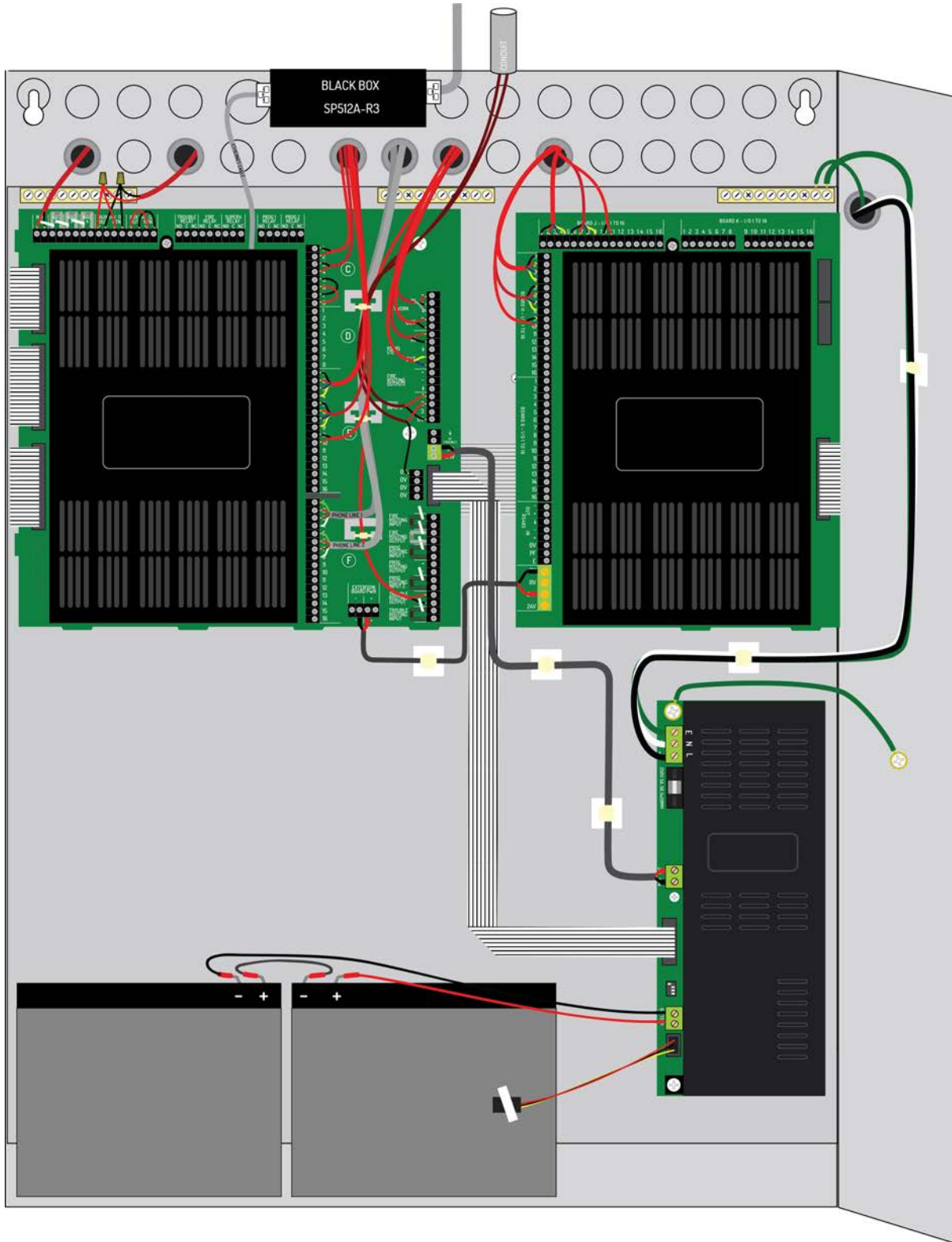

Extension Board Features

The following figure illustrates the Extension Board features:

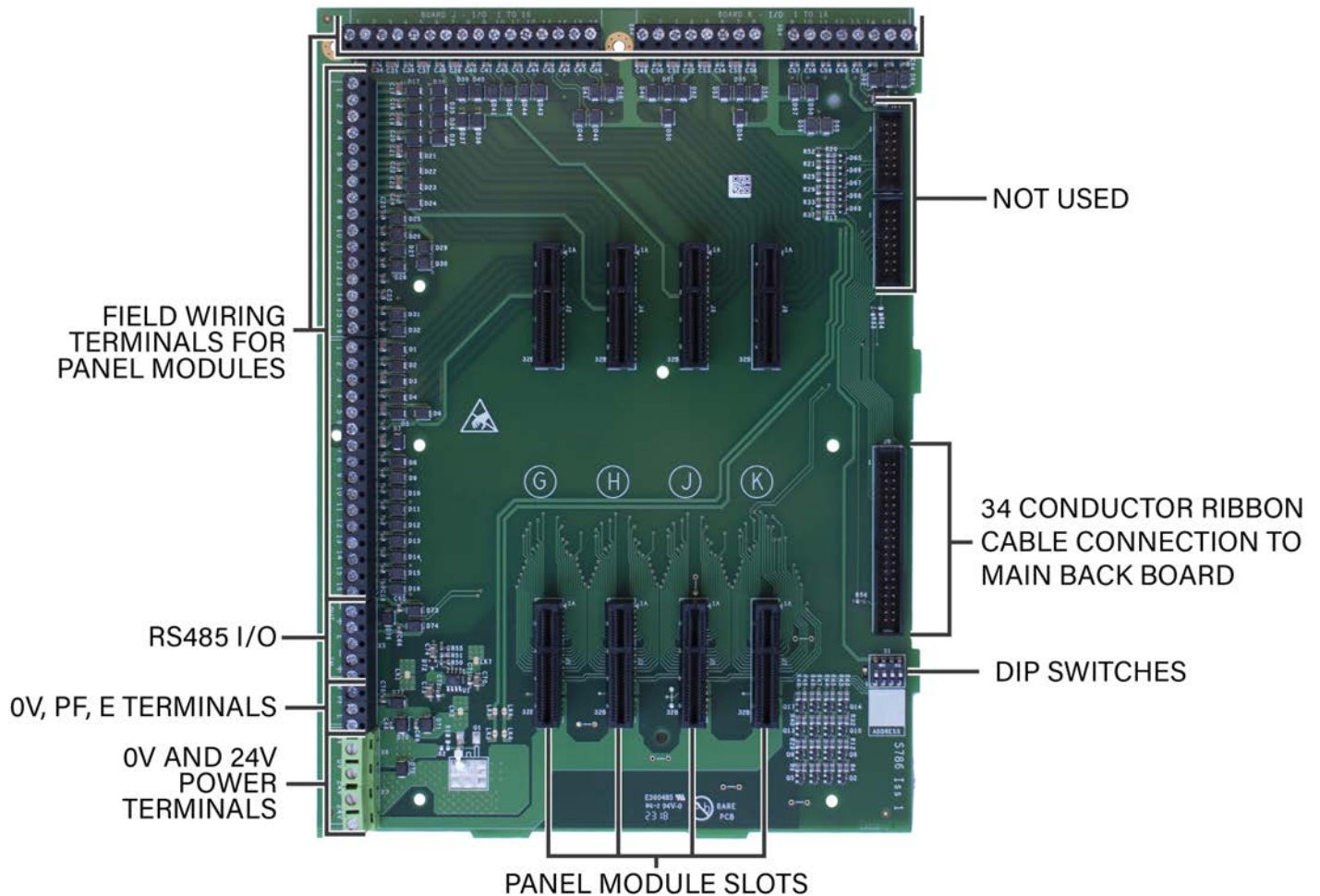

The extension board is connected to the Main Back Board through the Extension Board Power Terminals and a 34 Conductor ribbon cable. The DIP switches should be set as shown.

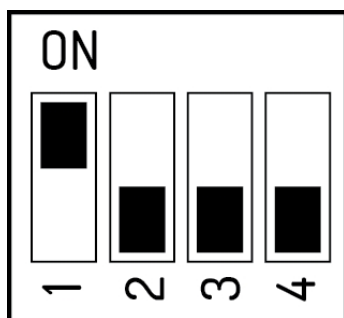

Panel Module Slots and Terminals

Panel module slots and field terminals of the FireNET L@titude Fire Alarm Control Panel contain corresponding lettering to identify position on the Extension Board. Slots G, H, J, and K correspond to terminals G, H, J, and K of the Extension Board.

Board Slot G, H, J, K

Field Terminals	Board Location	Possible Panel Modules	No. of Circuits	Function
1-8 (9-16 not used)	Slot G, H, J, K	Dual Loop Panel Module	2	SLC In / Out
1-8 (9-16 not used)	Slot G, H, J, K	4 Channel NAC Panel Module	4	NAC Outputs
1-16	Slot G, H, J, K	8 Channel Relay Panel Module	8	Form A Dry Contacts
1-16	Slot G, H, J, K	8 Channel Conventional Zone Panel Module	8	Two-wire Initiating Device Circuits (IDC)
1-16	Slot G, H, J, K	16 Channel I/O Panel Module	16	Input / Output Circuits

Slot G

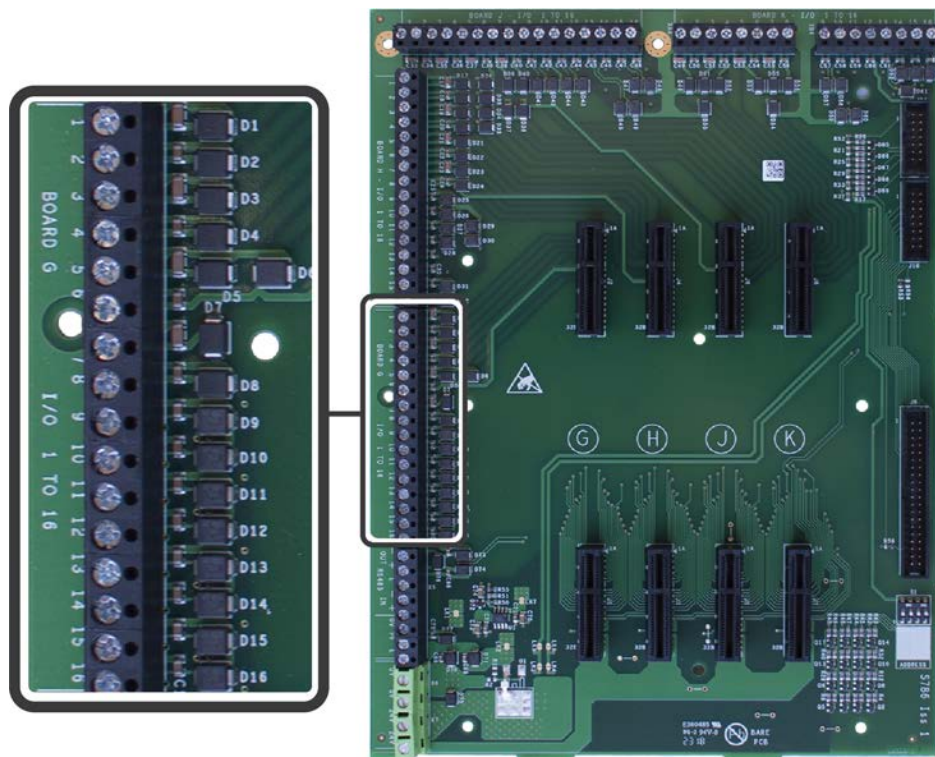

Slot H

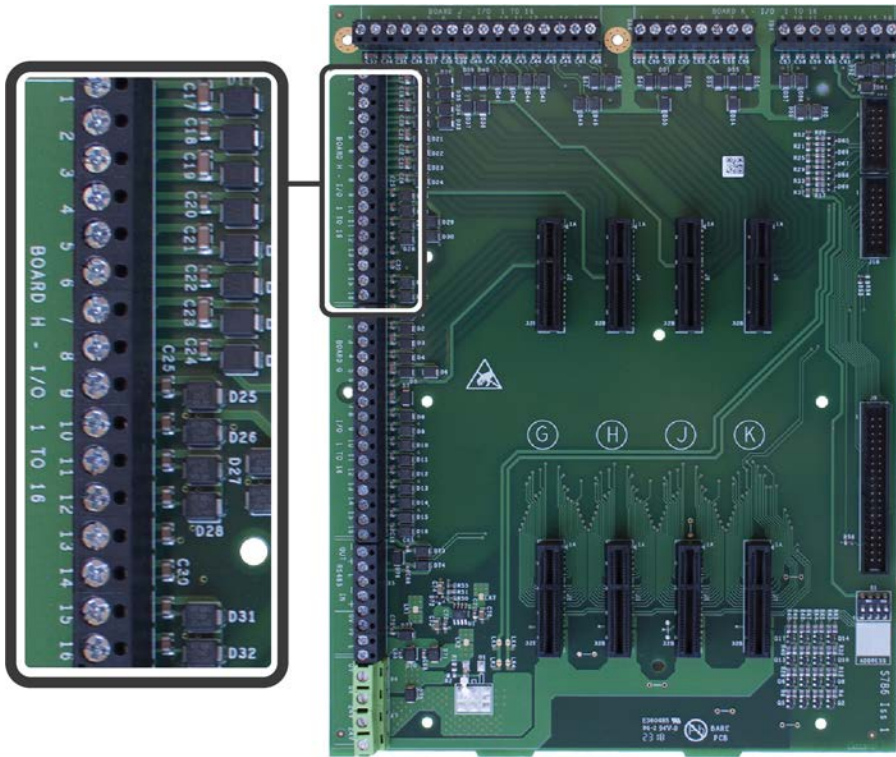

Slot J

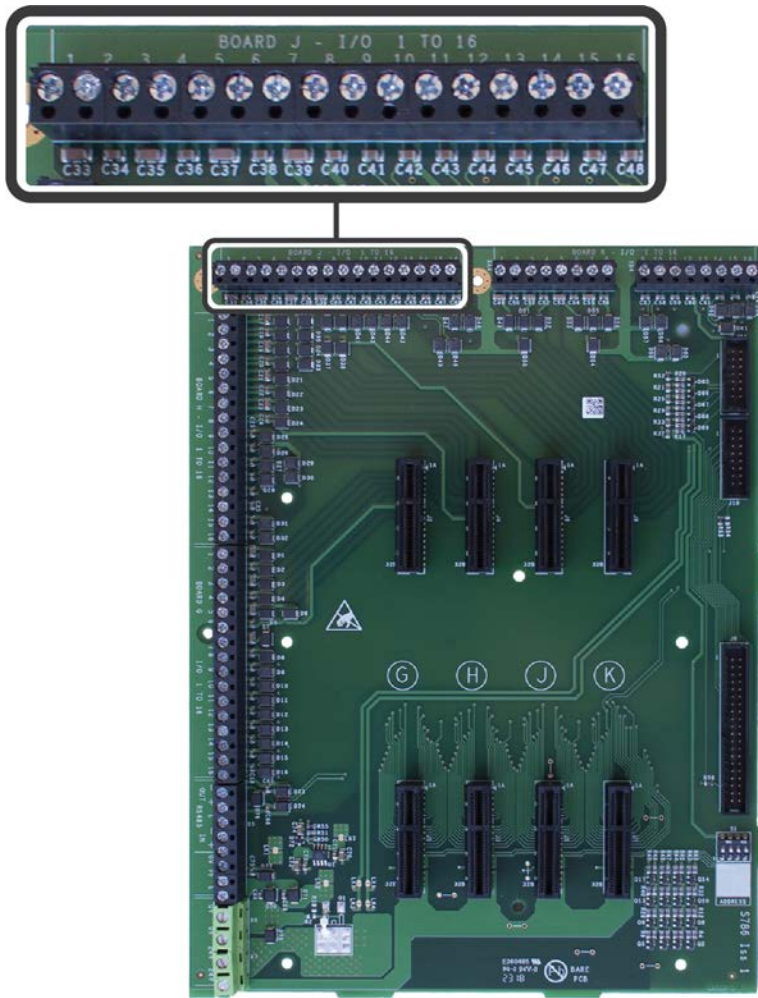

Slot K

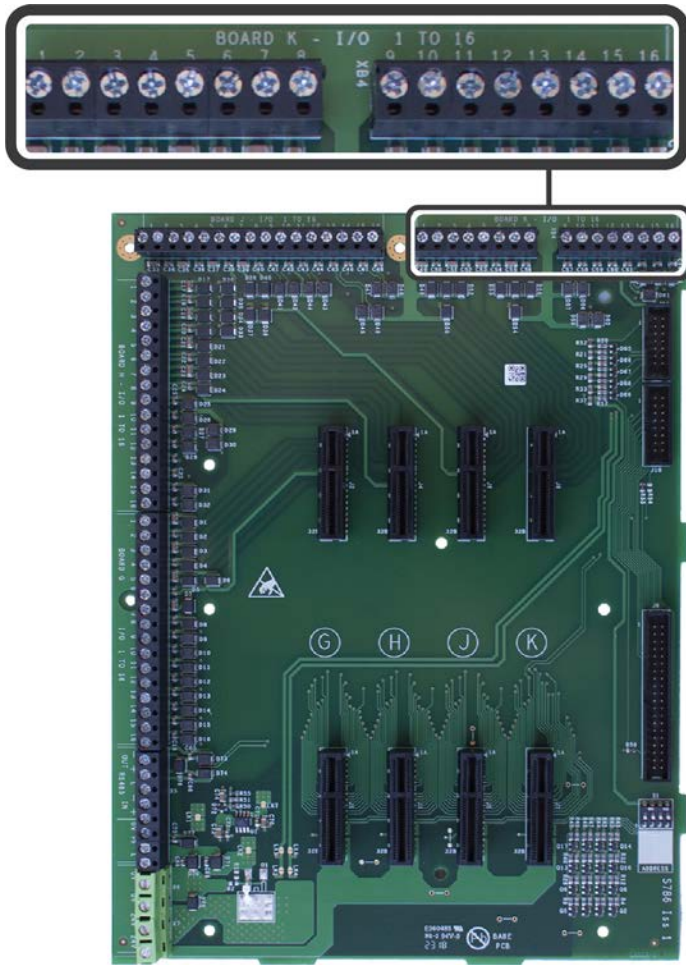

Other Terminals

Location	Field Wiring Terminals	Function
RS-485 I/O	N/A	Not currently used. For future use.
0V, PF, E	N/A	Not currently used. For future use.
24V and 0V Power Terminals	N/A	Used to power the board through a connection to the Main Back Board.

LCD MAIN PROCESSOR BOARD (S721)

The LCD Main Processor Board provides the touch display, central processing, and memory for the FireNET L@titude Fire Alarm Control Panel. The LCD Main Processor Board mounts to the fascia of the FireNET L@titude Fire Alarm Control Panel and includes hardware features such as connectors, ports, switches, LED indicators, and the internal buzzer.

The LCD Main Processor Board, optional Zone LED module(s), and optional L@titude Printer are mounted on the fascia of the FireNET L@titude Fire Alarm Control Panel. The LCD Main Processor Board can operate a maximum of three Zone LED modules. One Zone LED module provides 48 LED indicators, two provides 96 LED indicators, and three Zone LED modules provide 144 LED indicators.

Zone LED modules connect to the LCD Main Processor Board through a 10 conductor cable. Subsequent Zone LED modules are connected in sequence through additional 10 conductor cables.

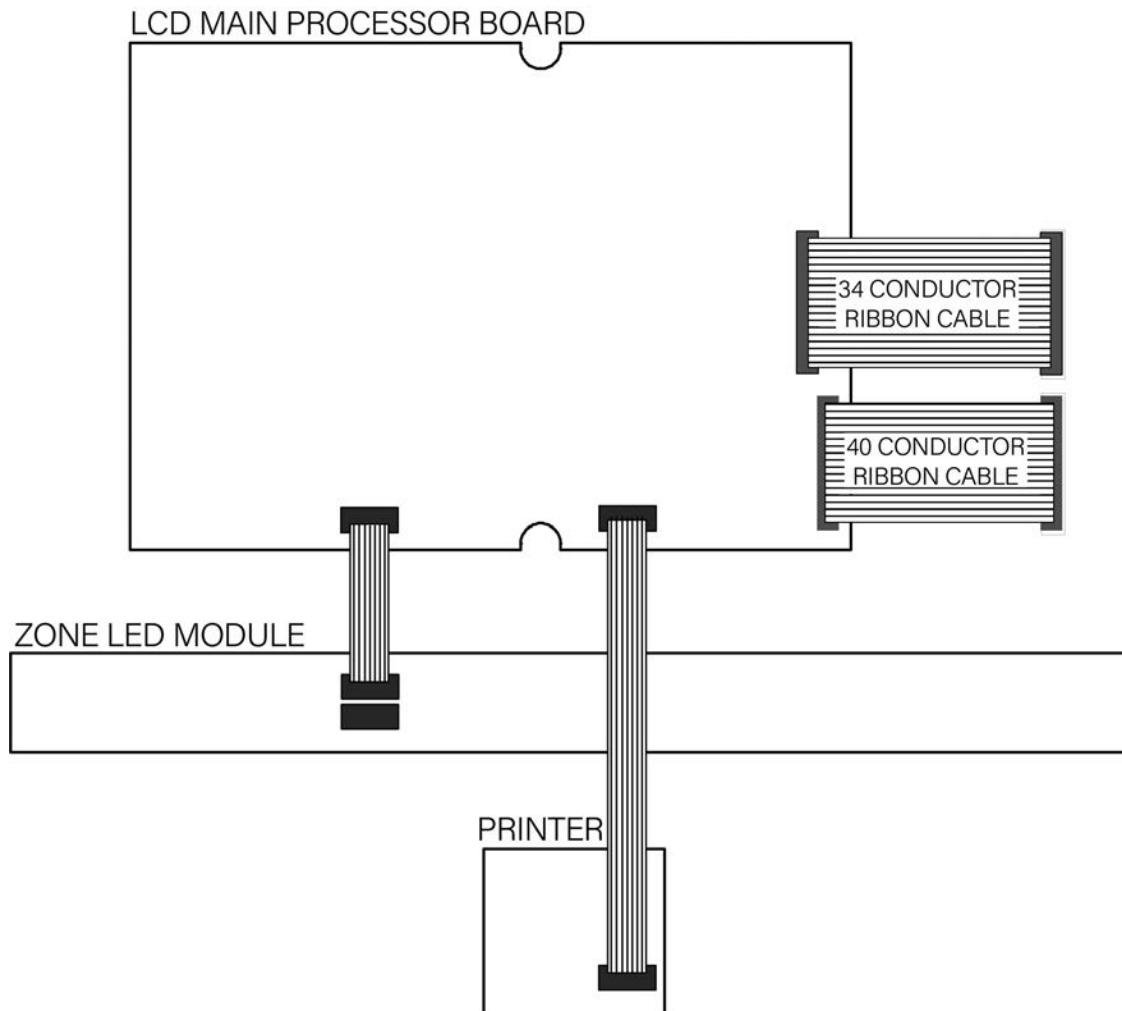

Connectors and Ports

The following figure illustrates connectors and ports of the LCD Main Processor Board:

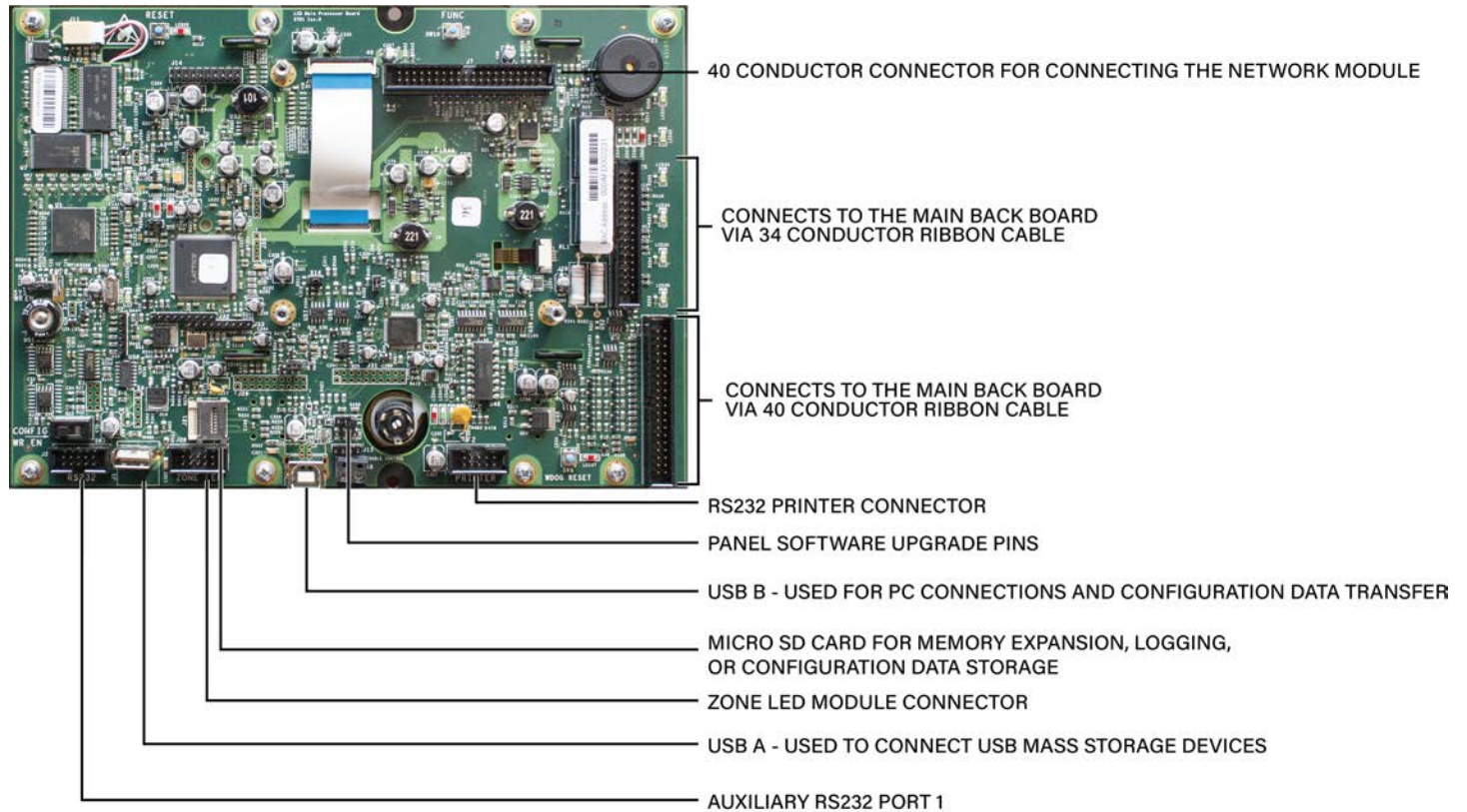

Switches, LED Indicators, and Internal Buzzer

The following figure illustrates switches, LED indicators, and the internal buzzer of the LCD Main Processor Board:

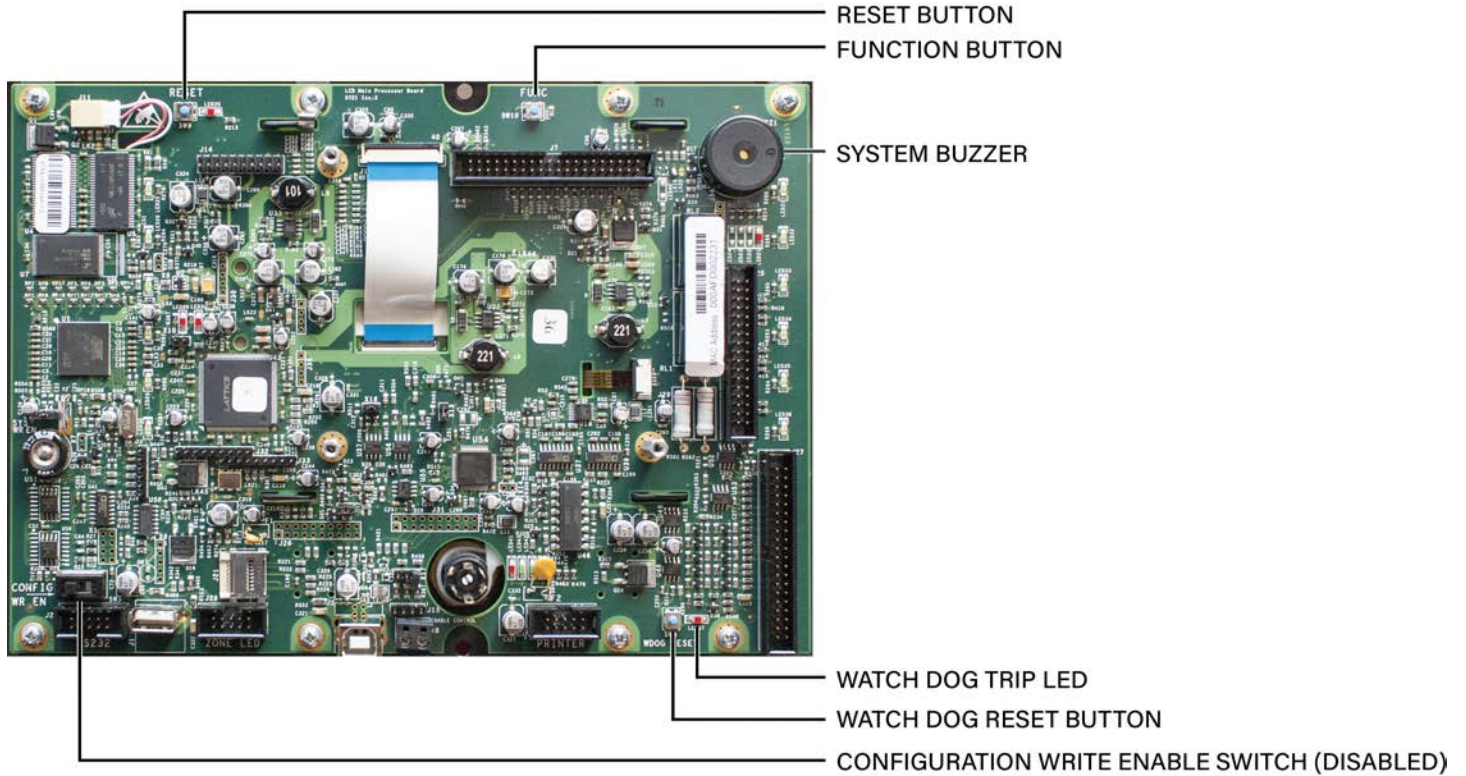

19 INCH RACK MOUNT ENCLOSURE

The 19" Rack Mount Enclosure provides the same functionality as the other L@titude cabinets, but is made to fit in a server rack cabinet. It provides slots for required and optional panel modules, as well as for field wiring and power supply terminations. However, it requires a separately-purchased external battery cabinet.



Installation

This section provides instructions for connecting cables, mounting, and testing the 19" Rack Mount Enclosure. The following is a general checklist for the installation of the enclosure.

WARNING! Ensure AC mains is turned off and battery power is disconnected at the source before making any field connections. Double-check all termination points before applying power! Incorrectly terminated wiring may cause permanent damage.

IMPORTANT! The 19" Rack Mount Enclosure installation must be performed by qualified service personnel. Exercise care when fastening the cabinet to the rack. Electronic components within the enclosure are vulnerable to physical damage from severe shock and vibration.

	Task
<input type="checkbox"/>	Obtain required mounting hardware, tools, batteries, and external battery cabinet.
<input type="checkbox"/>	Open and remove the hinged door from the FACP Rack Mount Enclosure.
<input type="checkbox"/>	Following the manufacturer's instructions, configure the (separately-purchased) battery cabinet for 24V operation.
<input type="checkbox"/>	Install the battery cabinet.
<input type="checkbox"/>	Install the FACP cabinet in the 19" rack in close proximity to the battery cabinet.
<input type="checkbox"/>	Route field wiring to the FACP. Dress it in a manner to ensure proper separation of low-voltage wiring, telecommunications wiring (if any), and AC power wiring.
<input type="checkbox"/>	Secure the cabling to the terminals.
<input type="checkbox"/>	Connect the battery leads of the FACP power supply to the appropriate connections of the battery cabinet.
<input type="checkbox"/>	Reattach the hinged door.
<input type="checkbox"/>	Apply power to the panel from the AC source and install batteries.
<input type="checkbox"/>	Program the panel.
<input type="checkbox"/>	Test the installation.

Batteries

Refer to Calculations for determining the minimum required battery capacity for the fire alarm system.

WARNING! Battery terminals and leads are not power-limited. Shorts can cause a fire or an explosion. Use extreme caution while connecting standby batteries. To ensure the battery is not short-circuited, do not connect the batteries until all wiring of the battery cabinet and power supply is complete. The final wiring connection must be made at the terminal of the battery.

An appropriately-sized auxiliary UL listed battery cabinet suitable for fire alarm service will be required. When using a rack mount battery cabinet, it is recommended to mount it directly below the FACP. Configure the battery cabinet to provide 24VDC with a capacity meeting or exceeding the minimum required. Refer to the documentation of the selected battery cabinet for specific wiring and installation instructions.

Connect the 24V output of the battery cabinet to the BATTERY connections on the FACP Power Supply module. The cable connecting the power supply and battery must be a jacketed cable with a VW-1 flame rating. The cable between the power supply and the battery cabinet should be kept as short as possible. It must be no longer than 5 feet if using 12 AWG wire or 3 feet if using 14 AWG wire.

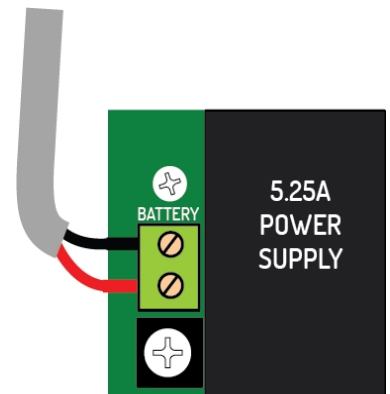

NOTE The most commonly available wire that meets these requirements is heavy duty outdoor extension cords of type SJ, which would need to be modified to suit the application.

Connecting Field Wiring

Power-limited conductors must be installed using Types FPL, FPLR, FPLP, or equivalent cables.

Separate high and low voltage wiring in the enclosure with a minimum gap of 0.25". Do not route low-voltage cabling through the non-power-limited area. The non-power-limited wiring area is shown below behind the yellow diagonal lines.

To maintain positioning of the ferrite, secure the AC and neutral lines exiting the ferrite to the ground wire with a wire tie as shown.

WARNING! To avoid injury and damage to the equipment, ensure AC mains is turned off and battery power is disconnected at the source before making any field connections. Double-check all termination points before applying power! Incorrectly terminated wiring may cause permanent damage.

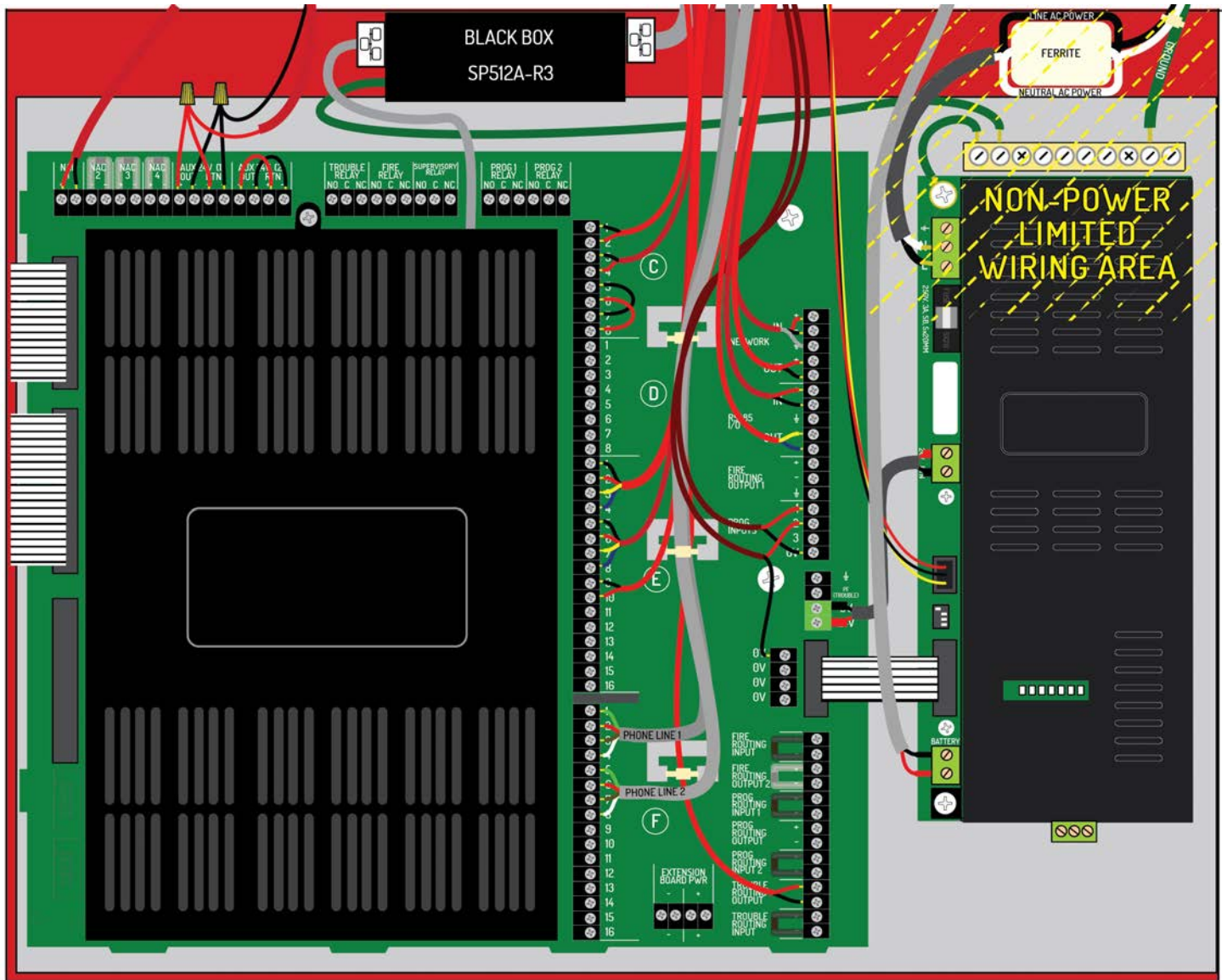

Power Supply

The 19" Rack Mount Enclosure is only available with the 5.25 Amp power supply.

POWER SUPPLIES

Models of the FireNET L@titude Fire Alarm Control Panel can include the 5.25 Amp or the 10.25 Amp power supply. 5.25 Amp power supplies are capable of charging batteries with capacities ranging from 7 to 60 Ah. 10.25 Amp power supplies are capable of charging batteries with capacities ranging from 12 to 100 Ah. Both power supplies provide an output voltage of 24V and accept input voltages of 115 VAC or 230 VAC .

A jumper connection for the 5.25 Amp power supply is set at the factory according to input voltage requirements of the customer, either 115 VAC or 230 VAC.

The 10.25 Amp power supply does not provide a jumper connection to select between input voltages. This power supply includes a universal input feature that automatically compensates for input voltages between 95V and 250V AC.

Features

Features of the power supplies include:

Features	Description
Deep Discharge Prevention	Prevents deep-discharge of the standby batteries by disconnecting the load when the standby battery-voltage drops below 19 +/- 1V DC. A deep-discharge can cause permanent damage to standby batteries. Preventing this condition allows standby batteries to recharge for continued operation after extended power outages.
Battery Backup	Provides battery power to the load when the AC input of the power supply falls below the rated level. The voltage at the load remains within the specified range during these switching-transitions.
Battery Boost	Boosts standby battery voltage to maintain a constant 22 VDC when the voltage drops below the 22 VDC level.
Short-Circuit Protection	Provides a shut down on the load side of the power supply when the load-current exceeds the maximum level.
Automatic Retry	Restores output to the load when operating conditions return to nominal levels. This feature restores voltage levels at the load following conditions such as over-current and AC restore.
Battery Impedance	Provides a trouble warning when the impedance of the battery reaches a level that could prevent proper system operation.
Battery Supervision	Battery presence and low battery voltage supervision
Ground Trouble Detection	Ground Trouble Detection
General Trouble Relay	All troubles are reported over the common trouble contacts.

DIP Switches

DIP switches are located on the edge of the power supply.

This figure illustrates the location of DIP switches on the 5.25 Amp Power Supply.



The tables below describe DIP switch settings 1 through 4 of the 5.25 Amp Power Supply. For UL compliance, DIP switches should be set to the defaults, as shown.

SW1&2 together define the Battery Load Test (also known as Battery Impedance Test)

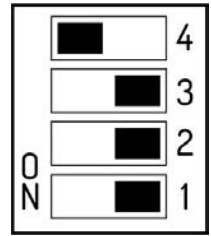

Switch 1	Switch 2	Description
Off (DEFAULT)	Off (DEFAULT)	Recommended for standard operation. Load test the battery every 59 minutes. Measured voltage drop > 900mV fails the test.
Off	On	NOT USED. Load test the battery every 59 minutes. Measured voltage drop > 1100mV fails the test.
On	Off	Disable trouble reporting of disconnected standby batteries. Load test the battery every minute. Measured voltage drop > 900mV fails the test. This setting also masks BATTERY_MISSING troubles.
On	On	Disable trouble reporting of standby battery impedance. No load test performed.

SW3 is not used on the 5.25 Amp Power Supply and should be set to OFF. SW4 defines Battery Manufacturer.

Switch 4	Description
On (DEFAULT)	Sets standby batteries for the Powersonic manufacturer.
Off	Sets standby batteries for the Yuasa manufacturer.

Other manufacturer batteries can be used. Consult the manufacturer's datasheet for proper settings.

10.25 Amp Power Supply

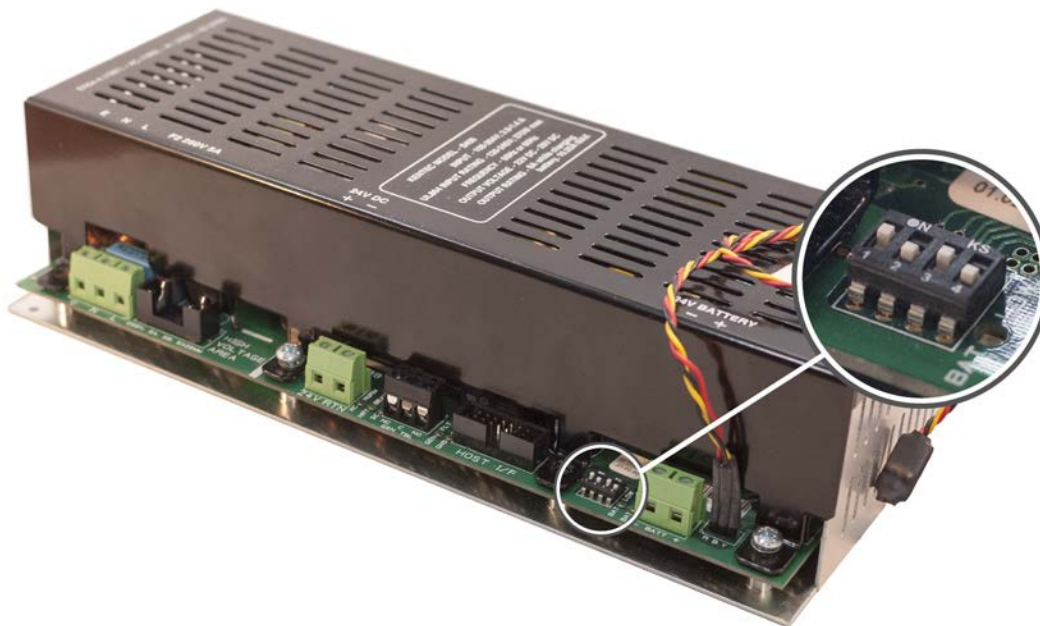

The tables below describes DIP switch settings 1 through 4 of the 10.25 Amp Power Supply.

For UL compliance, DIP Switches 1 and 2 must be set to the default, as shown.

Switch 1: Operating Mode	
On	Special Application Mode
Off (DEFAULT)	Recommended for standard operation.
Switch 2: Ground Trouble Detection	
On (DEFAULT)	Static: Setting required for interfacing to legacy products. Ground is pulled to a static voltage between 24V and RTN (1/2 of 24V-OUT).
Off	Dynamic: Ground is pulled to a dynamic voltage, varying from 6-18V over a 6 second period.
Switch 3: Battery Size	
On	Sets standby battery capacity \leq 18 Ah.
Off	Sets standby battery capacity $>$ 18 Ah.
Switch 4: Battery Manufacturer	
On	Sets standby batteries for the Powersonic manufacturer.
Off	Sets standby batteries for the Yuasa manufacturer.

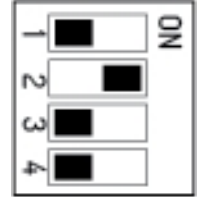

- Disabling Battery Indication - Set DIP switch 1 to the ON position, DIP switch 3 to the ON position and DIP switch 4 to the OFF position to disable the "BATTERY DISCONNECTED" warning indication.
- Disabling the Impedance Test - Set DIP switch 1 to the ON position and DIP switch 3 to the OFF position to disable the battery impedance test and trouble reporting.

Special Application Mode Table

SW1	SW2	SW3	SW4	Battery Mfr.	Battery Size	Ground Trouble Detection	Impedance Test Intervals	Battery Missing Trouble
ON	ON	ON	ON	RESERVED FOR FUTURE USE				
ON	ON	OFF	ON	PowerSonic	$>$ 18 Ah	Static	Disabled	Reported
ON	ON	ON	OFF	Yuasa	$<$ 18 Ah	Static	1 min	Masked
ON	ON	OFF	OFF	Yuasa	$>$ 18 Ah	Static	Disabled	Reported

Light shading of the table indicates "production" or "demo" use.
 Dark shading of the table indicates a "normal, but impedance test disabled" use.

Status Indicators

LED Indicator	Condition
AC NORMAL	The AC power is connected.
EARTH FLT	The 24V DC supply is connected to the ground.
CHARGER FAULT w/ abnormal	An internal fault has been detected in the power supply module. The HEARTBEAT

LED Indicator	Condition
HEARTBEAT	indicator blinks different patterns to indicate the fault. 1-1 AC Power is on and 24V output is not in regulation. 1-2 The battery voltage is too high. 1-3 The battery charge current is too high. 1-4 The battery charge current is low while the charger output current control is MAXed.
BATTERY LOW (no CHARGER FAULT)	The unit is operating from battery and the battery voltage is below 21 V OR The unit is operating from AC power and the battery voltage is below 24 V.
BATTERY LOW and CHARGER FAULT	The battery impedance exceeds the acceptable limit. Install new batteries.
BATTERY DISCON	Standby batteries are disconnected.
HEARTBEAT	The power supply is functioning.
DC OUT ON	The 24V DC supply is supplying power to the load.

EVENTS AND STATUS

This section describes events and the status of the panel GUI while operating the FireNET L@titude Fire Alarm Control Panel. The following events are described:

- Fire
- CO
- Trouble
- Supervisory
- Disablement
- Other Events

These event types correspond to the tabs displayed at the top of the Panel GUI. The event tabs will numerically indicate active events on the panel; the event type with the highest active event priority will automatically be displayed. Any event type can be accessed by pressing the associated tab.

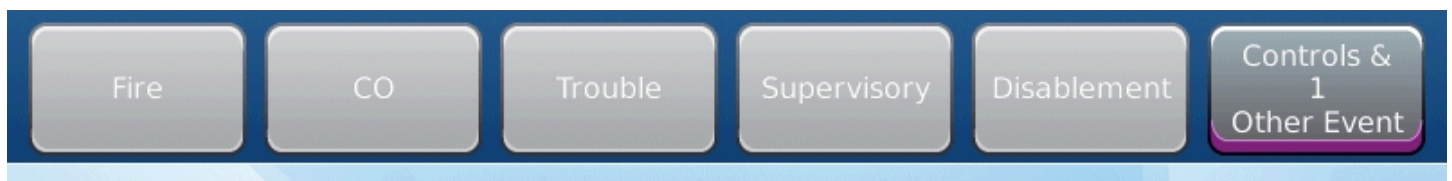

Fire

In the event of a fire,

- the **Fire** indicator on the front of the panel flashes red
- the applicable indicator on the Zone LED Board flashes (if connected)
- the panel GUI displays details about the **Fire** event
- fire warning notification appliances activate as programmed
- panel outputs programmed to operate in the event of a fire, such as the Fire Relay and the Fire Routing Output 2, will activate
- the panel buzzer activates

With Access Level 2 or higher, the following functions are available:

- **Silence Alarms:** Press **Activate Controls**> **Silence Alarms** to silence notifications. The notifications can be reactivated by pressing the **Re-Sound Alarm** button.
- **Buzzer Silence:** Press **Buzzer Silence** to silence the panel buzzer.
- **Reset System:** Press **Reset System**.

CO

In the event of a CO Alarm, the following things happen:

- the **CO Alarm** indicator on the front of the panel illuminates yellow
- the applicable indicator on the Zone LED Board flashes (if connected)
- the panel GUI displays details about the **CO Alarm**
- CO warning notification appliances activate as programmed
- the panel buzzer activates

With Access Level 2 or higher, the following functions are available:

- **Silence Alarms:** Press **Activate Controls> Silence Alarms** to silence notification appliances. They can be reactivated by pressing the **Re-Sound Alarm** button.
- **Buzzer Silence:** Press **Buzzer Silence** to silence the panel buzzer.
- **Reset System:** Press **Reset System**.

Trouble

If there is a trouble on the system, the following things will happen:

- the **General Trouble** indicator on the front of the panel flashes yellow

There may be other trouble LED indications which identify the nature of the trouble.

- panel outputs programmed to operate in the event of a trouble, such as the Trouble Relay and Trouble Routing outputs, will activate
- the panel GUI displays details about the **Trouble**
- the panel buzzer activates

Troubles will typically reset automatically once the condition has cleared. With Access Level 2 or higher, the following functions are available:

- **Silence Alarms:** Press **Activate Controls> Silence Alarms** to silence notification appliances. They can be reactivated by pressing the **Re-Sound Alarm** button.
- **Buzzer Silence:** Press **Buzzer Silence** to silence the panel buzzer.
- **Reset System:** Press **Reset System**.

Supervisory

If there is a Supervisory Alarm on the system:

- the **Supervisory Alarm** indicator on the front of the panel illuminates yellow
- panel outputs programmed to operate in the case of a Supervisory event, such as the Supervisory Relay, will activate
- the panel buzzer activates
- the panel GUI displays details about the **Supervisory Alarm**

Supervisory Alarms will typically reset automatically once the condition has cleared (device may be programmed latching or non-latching). With Access Level 2 or higher, the following functions are available:

- **Silence Alarms:** Press **Activate Controls**> **Silence Alarms** to silence notification appliances. They can be reactivated by pressing the **Re-Sound Alarm** button.
- **Buzzer Silence:** Press **Buzzer Silence** to silence the panel buzzer.
- **Reset System:** Press **Reset System**.

Disablement

If there is a Disablement on the system:

- the **Disablements** indicator on the front of the panel illuminates yellow
- the panel buzzer activates
- the panel GUI displays details about the **Disablement**

If one or more disablements are active, the panel generates a trouble. Refer to the [Trouble](#) section above. Disablements will reset automatically once the device or zone has been re-enabled. With Access Level 2 or higher, the following functions are available:

- **Silence Alarms:** Press **Activate Controls**> **Silence Alarms** to silence notification appliances. They can be reactivated by pressing the **Re-Sound Alarm** button.
- **Buzzer Silence:** Press **Buzzer Silence** to silence the panel buzzer.
- **Reset System:** Press **Reset System**.

Other Events

Other event statuses are displayed in the **Controls & Other Events** tab.

MAINTENANCE AND REPAIR

This section provides procedures to maintain and repair the FireNET L@titude Fire Alarm Control Panel over the operating life of the product. Refer to Equipment List for component part numbers described in this section.

IMPORTANT! The FireNET L@titude Fire Alarm Control Panel maintenance and repair must be performed by qualified service personnel.

Batteries

Load test the batteries and inspect their connections to the power supply as part of annual system maintenance.

WARNING! Battery terminals and leads are not power-limited. Shorts can cause a fire or an explosion. Use extreme caution while connecting standby batteries.

Replacing Battery Leads

When replacing leads, disconnect them from the battery before disconnecting them from the power supply.

Replacing Standby Batteries

Typical battery life is 5 years. Specify replacement batteries that are Valve Regulated Lead Acid (VRLA) types.

Removing the Standby Batteries

To remove the existing standby batteries:

1. Disconnect the jumper between Battery 1 and Battery 2.
2. Disconnect the black lead from the negative terminal of Battery 1.
3. Disconnect the red lead from the positive terminal of Battery 2.
4. Remove Battery 1 and Battery 2 from the bottom of the FireNET L@titude Fire Alarm Control Panel cabinet.
5. Recycle Battery 1 and Battery 2 according to the manufacturer procedures provided in the battery packaging.

Installing the Standby Batteries

Refer to Connecting Standby Batteries for information describing the standby battery installation process.

Fuses

The FireNET L@titude Fire Alarm Control Panel contains fuses to protect it against overloads. During the life of the product it may be necessary to replace one or both of the fuses. Replace fuses only after addressing the cause which resulted in the fuse failure.

Battery Lead Fuse on 5.25A Power Supply

Failure of the battery lead fuse will result in a **Battery Missing** trouble. Verify that the fuse is the problem by disconnecting the fused-lead from the battery, and measuring the resistance of the lead from end-to-end with an ohm meter. The resistance should measure less than 1 ohm. If it measures higher, replace the fuse with a UL listed slow blow fuse. After replacing the fuse, measure the resistance again. If it still measures higher than 1 ohm, replace the lead. Refer to the [Equipment List](#) for fuse part numbers.

Once the replacement is complete, reconnect the lead to the battery terminal and verify the **Battery Missing** trouble has cleared.

Refer to Equipment List for parts supporting the assembly and connection of the fuse.

Replacing the Power Supply Fuse

Failure of the power supply fuse will result in a **Power Failed** trouble. Verify that the internal fuse is the problem by checking that the proper AC voltage is present across the L & N terminals on the AC-in terminal block of the power supply.

WARNING! This is high voltage area. An electrical shock hazard exists. Use extreme care.

If the terminals have proper AC voltage and the green AC NORM indicator on the power supply is not lit, disconnect AC power at the source and replace the fuse.

Replace the power supply fuse by removing it from the fuse housing contained on the circuit board of the power supply. Install the replacement fuse in the fuse housing and then test the power supply to determine that it operates. The following figure illustrates the fuse of the power supply:

Removing the Power Supply Fuse

1. Turn off the AC power feed to the fire control panel. It is not necessary to disconnect the batteries.

WARNING! This is a high voltage circuit area. An electrical shock hazard exists in this area when the fire control panel is operating. Do not remove the fuse while powering the fire control panel. Remove AC power at the source before attempting to remove the fuse of the power supply.

2. Locate the housing containing the fuse.
3. Remove the upper-half of the fuse housing with long nose pliers.
4. Remove the fuse from the upper-half of the fuse housing.

Installing the Replacement Power Supply Fuse

WARNING! This is a high voltage circuit area. An electrical shock hazard exists in this area when the fire control panel is operating. Do not replace the fuse while powering the fire control panel. Remove AC power at the source before attempting to replace the fuse of the power supply.

1. Insert and center the replacement fuse in the upper housing.

For the 5.25A power supply, use only a UL listed 250V, 3A, slow blow, 5x20mm fuse.

For the 10.25A power supply, use only a UL listed 250V, 5A, slow blow, 5x20mm fuse.

2. Press the upper housing on the lower housing until the halves snap together. The following figure illustrates the closed fuse housing:

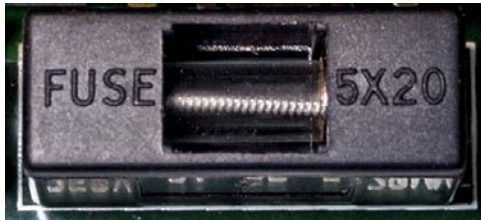

3. Restore AC power.
4. Monitor the AC NORMAL and DC OUT ON LED indicators on the power supply of the FireNET L@titude Fire Alarm Control Panel to determine that trouble conditions are not reported following fuse replacement.

Replacing Internal Components

It may be necessary to remove and replace internal components during the operating life of the panel. The fascia contains the LCD Main Processor Board, optional Zone LED module, and optional printer. The backplate contains the Main Back Board, the power supply, and grounding terminals. Refer to Removing Cabinet Components for instructions on removing and replacing internal components. Ensure that AC power is off before replacing internal components.

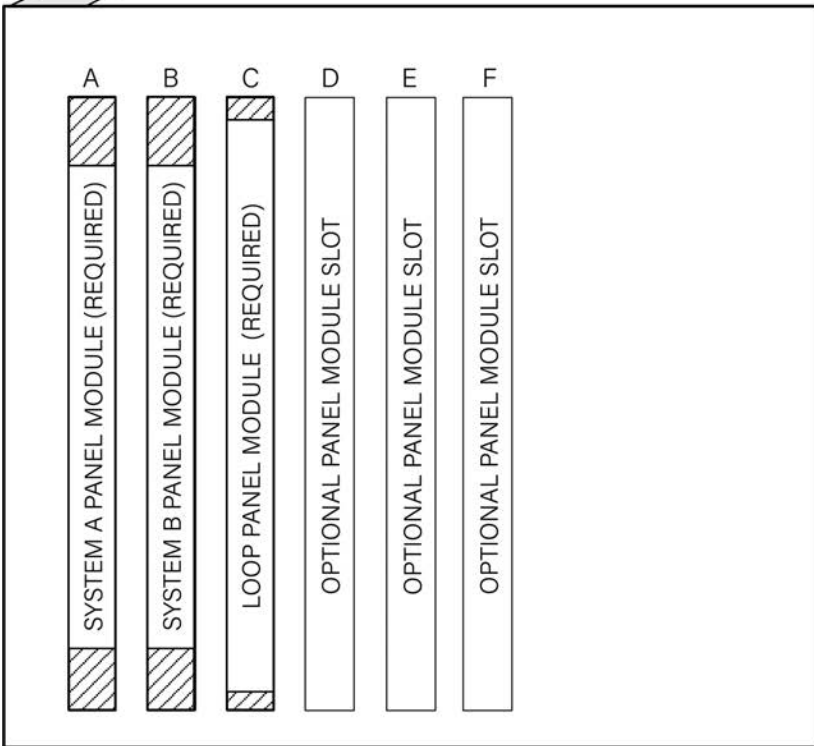
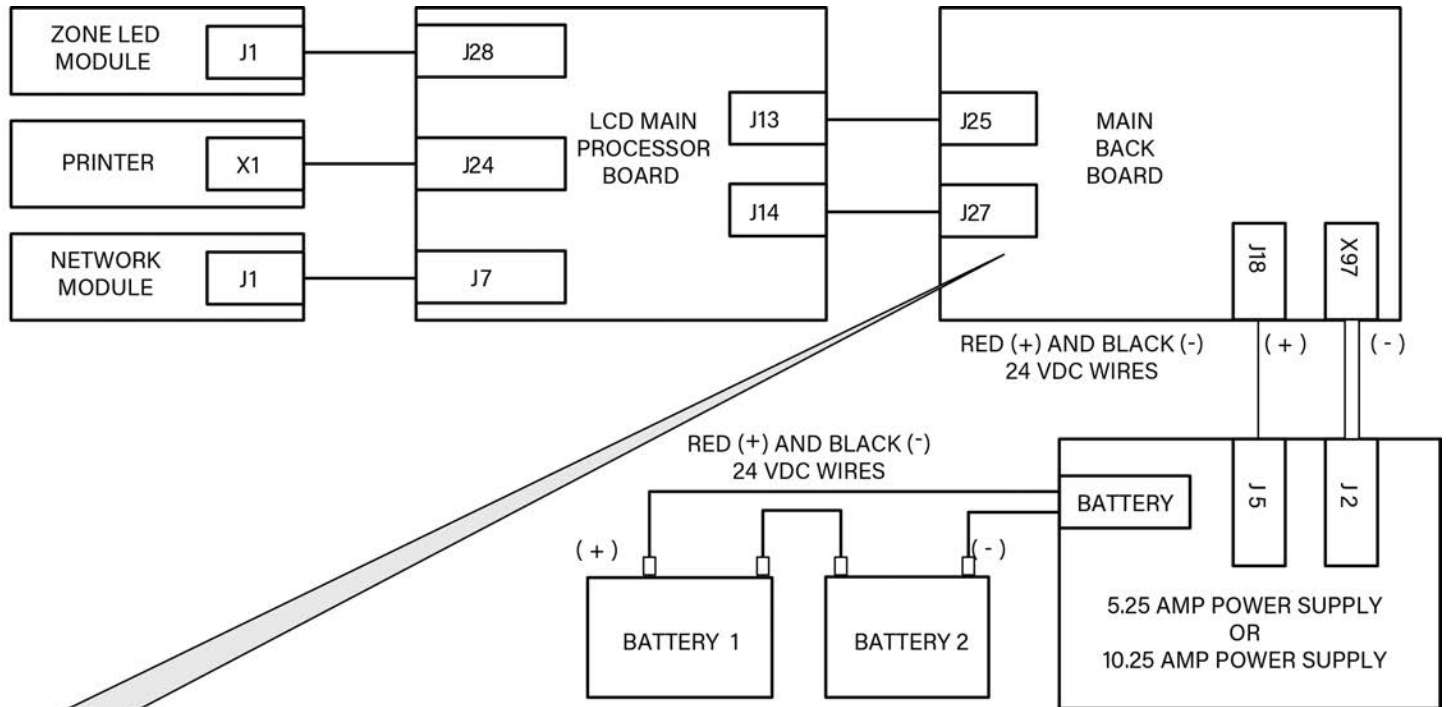

APPENDIX A: SPECIFICATIONS

This appendix provides electrical and environmental specifications for the FireNET L@titude Fire Alarm Control Panel. Current levels provided in the tables of this appendix are maximum ratings unless otherwise indicated.

Operating Constraints

Installation of the FireNET L@titude Fire Alarm Control Panel must include the operating constraints of the system to maintain continuous signal monitoring and reporting. Operating constraints are based on the current-driving capability of the panel while maintaining external loading caused by devices and cabling.

External loading must be selected within the limits of the FireNET L@titude Fire Alarm Control Panel to provide continuous operation. External loading is caused by individual or multiple combinations of Signaling Line Circuits, Notification Appliance Circuits, and Initiating Devices. It is also caused by the size and length of cabling connections. Refer to Calculations to determine the appropriate size and length of cabling.

Electrical

AC Input Ratings

Terminal	Description	Power Supply	Power
L	AC line	5.25 A	1.83 Amps Max @ 115 V, 50/60 Hz 0.915 Amps Max @ 230 V, 50/60 Hz
		10.25 A	2.5 Amps Max @ 115 V, 50/60 Hz 1.25 Amps Max @ 230 V, 50/60 Hz
N	AC neutral		
	Ground		

AC line and AC neutral terminals are supervised for open and short circuits, provided standby batteries are functional.

Power Supply

Fuses

Power Supply	Description
5.25 A	AC Input, 3 A, 250 VAC, slow blow, 5 x 20 mm
10.25 A	AC Input, 5 A, 250 VAC, slow blow, 5 x 20 mm

24 VDC Output Ratings

Designation	Description
Output voltage	22V DC minimum, 26.4V DC maximum
Ripple Voltage	1 V Maximum
Maximum Standby Current	Rated maximum output current which can be supplied continuously in normal standby.
S406 5.25A Power Supply	1.9 A
S408 10.25A Power Supply	3.4 A
Maximum Alarm Current	Rated maximum output current which can be supplied in alarm.
S406 5.25A Power Supply	4 A
S408 10.25A Power Supply	8 A

Standby Battery Ratings

Designation	Description
AH max	Maximum battery capacity in amp hours for 5.25 A and 10.25 A Power Supplies
5.25 A	60 AH maximum
10.25 A	100 AH maximum
Ri max	Maximum series resistance in battery charging circuit before a trouble is indicated.
5.25 A	1 Ohm
10.25 A	0.4 Ohm

Ground Trouble Indication

A ground trouble indication occurs on the FireNET L@titude Fire Alarm Control Panel when 15K Ohms or less exists between the ground and either DC RTN or +24 VDC of the power supply.

System Power

When AC power is present, the system operates entirely from AC power (primary). During an AC power failure, the entire system load is transferred to the standby batteries (secondary).

Standby and Alarm Current

Standby and Alarm Currents of the FireNET L@titude Fire Alarm Control Panel with two loops are provided below. Two loop operation includes System A Panel Module, System B Panel Module, and the Dual Loop Panel Module. Two loop operation represents the minimum board configuration of the FireNET L@titude Fire Alarm Control Panel. The data excludes all external loads. Primary loads assume a fully charged battery.

5.25 A Power Supply

Standby Load (mA)	Alarm Load (mA)	Description
244 mA @ 115 VAC	272 mA @ 115 VAC	Line current for standby and alarm when battery charge current is less than 30 mA.
162 mA @ 230 VAC	177 mA @ 230 VAC	Line current for standby and alarm when battery charge current is less than 30 mA.
560 mA @ 24 VDC	650 mA @ 24 VDC	Battery current for standby and alarm when AC power failure condition is present.

10.25 A Power Supply

Standby (mA)	Alarm (mA)	Description
220 mA @ 115 VAC	234 mA @ 115 VAC	Line current for standby and alarm when battery charge current is less than 30 mA.
176 mA @ 230 VAC	181 mA @ 230 VAC	Line current for standby and alarm when battery charge current is less than 30 mA.
550 mA @ 24 VDC	620 mA @ 24 VDC	Battery current for standby and alarm when AC power failure condition is present.

The data provided above for standby and alarm current includes loads of a two loop fire control panel alone and excludes current loads from external devices or equipment.

Battery

Rechargeable Standby Battery Circuit

Designation	Description
Standby Battery Type	Two 12 VDC, rechargeable, valve-regulated, lead-acid batteries wired in series
Charger Type	Temperature compensated, current limited float charger
Low Battery Disconnect Voltage	19 V (+/- 1 volt)
Standby Battery Capacity	Installation-dependent. Refer to Determining the Standby Battery Capacity to determine the amp hour rating of the standby batteries.
Standby Battery Charge Voltage	27.6 V nominal, temperature-compensated and current-limited
Charge Current	Maximum charging current of standby batteries.
5.25 Amp Power Supply	1.25 A
10.25 Amp Power Supply	2.25 A

Standby Battery Loads

Standby battery loads are generated by measuring the series battery current of the power supply following a power failure condition. Standby and alarm current of the FireNET L@titude Fire Alarm Control Panel can include all or part of the following loads:

Loads	Standby Current	Alarm Current
5.25 A Power Supply	78 mA	78 mA
10.25 A Power Supply	80 mA	80 mA
Dual Loop Panel Module	115 mA	115 mA
NAC Outputs	0 mA (per output)	2500 mA (per output)
FireNET L@titude Fire Alarm Control Panel *	350 mA max	450 mA max
	335 mA typical	435 mA typical
Zone LED Module	5 mA	5 mA + 3 mA per LED
L@titude Network Module	80 mA	80 mA
L@titude Printer	0 mA	1500 mA (only during printing)
* LCD Main Processor Board, Main Back Board, System A Panel Module, System B Panel Module		

Cabling

Specify cabling that meets or exceeds NFPA 72 and UL 864 guidelines.

Cable Maximum Parameters for Network

Property	Ratings
Resistance	100 Ω total for both conductors
Core to Core Capacitance	300 nF
Core to Screen Capacitance	450 nF
Inductance Per Core	600 μ H

RS-485 Serial Data and Terminal Capacity

Property	Description
Serial Data Connection	up to 3900 feet of 18/2 FPLR
Maximum Terminal Capacity	14 AWG
Cable Maximum Parameters	25 Ω per conductor, 600 μ H per conductor, 300 nF

SLC Loop Ratings

The following ratings represent Hochiki DCP Protocol SLC loops of the FireNET L@titude Fire Alarm Control Panel.

Connection	Rating
LOOP (- OUT), (+ OUT)	36 V DC @ 400 mA
LOOP (- IN), (+ IN)	36 V DC @ 400 mA

Maximum Cable Capacitance: 1 μ F

Maximum Wiring Voltage Loss: 6.4 V

Refer to [SLC Loop Cabling](#) for maximum allowable cable length calculations.

Main Back Board

NAC Outputs

NAC Outputs	Terminal
NAC 1	(+), (-)
NAC 2	(+), (-)
NAC 3	(+), (-)
NAC 4	(+), (-)

NAC 1 and 2 can be configured to provide one Class A circuit (NAC 1&NAC 2) or two Class B circuits (NAC 1 and NAC 2).

NAC 3 and 4 can be configured to provide one Class A circuit (NAC 3&NAC 4) or two Class B circuits (NAC 3 and NAC 4).

Each NAC *circuit*, whether Class A or Class B, has the following ratings:

AUX Power Output Range	Channels configured to power non-NAC devices are rated special application 20V - 26.4V at 2A max, power-limited. Refer to NAC Power Output Modes for compatible devices.
Quiescent Current Consumption	30 mA
Maximum Current Consumption	50 mA (exclude current draw on outputs)
Current per NAC Output	2.5A per channel, power-limited
Fuse (Electronic)	Average Current Limit: 1 to 2.5A, programmable Peak Current Limit: 3.0 A, fixed per channel
Supervision	Reverse-polarity
End-of-Line Device	Diode (S2029)
Short Circuit Threshold	130 Ohms +/- 20%
Maximum Line Impedance	4V loss (load-dependent)

Regulated NAC Outputs

NAC outputs operate in a regulated mode when conforming to specific levels of continuous or pulsed DC. NAC outputs meet requirements for regulated levels when the output current does not exceed the constraints described below.

Regulated Non-Pulsing Output Current	Currents cannot exceed 2.5A from any single NAC output: Combined currents of all four NAC outputs cannot exceed 5A
--------------------------------------	----------------------------------------------------------------------------------------------------------------------------------

	System must not exceed maximum power supply output rating.
Regulated Pulsing Output Current	<p>5.25A Power Supply - Regulated pulsing DC output = Max 500mA total across all NACs</p> <p>10.25A Power Supply - Regulated pulsing DC output = Max 600mA from any NAC output, Max 2.4 A per Board</p> <p>System must not exceed maximum power supply output rating.</p>

Refer to Specifications for operating NAC outputs in the regulated mode.

Special Application NAC Outputs

NAC outputs can operate in a special application mode. NACs configured for special application have specific loading limitations, as detailed below.

Manufacturer	Maximum No. of Devices per Channel	Maximum Current Draw per Channel	Power Supply	Maximum Current Draw Across All NACs ¹
Amseco	27	2.4A	S406 5.25A	2.5A
			S408 10.25A	5A
Gentex	32	2.5A	S406 5.25A	2.5A
			S408 10.25A	5A
System Sensor	20	1.32A	S406 5.25A	2.1A
			S408 10.25A	5A
Wheelock	41	2.5A	S406 5.25A	2.5A
			S408 10.25A	5A

¹ When System Sensor is used in combination with any other manufacturer, the 2.1A limit applies across all NACs.

Refer to Specifications for operating NAC outputs in the special application mode.

AUX 24V

Terminal	Rating
AUX 24V (1) OUT (+) and (-)	Regulated 24 VDC @ 900 mA
AUX 24V (1) RTN (+) and (-)	Supervision only. Not an output.
AUX 24V (2) OUT (+) and (-)	Regulated 24 VDC @ 900 mA
AUX 24V (2) RTN (+) and (-)	Supervision only. Not an output.

Relay Ratings

Terminals	Connection	Ratings
(NO), (C), and (NC)	TROUBLE RELAY	<ul style="list-style-type: none"> Volt-free, Form C contacts 30V DC @ 1 A maximum, Resistive Programmable ACTIVE during complete power loss Not supervised
(NO), (C), and (NC)	FIRE RELAY SUPERV RELAY PROG 1 RELAY PROG 2 RELAY	<ul style="list-style-type: none"> Volt-free, Form C contacts 30V DC @ 1 A maximum, Resistive Programmable INACTIVE during complete power loss Not supervised

Network (RS-485)

Terminal	Rating
	Ground for cable shield (if applicable)
(+), (-) IN	Data 3.3 V, current-limited
(+), (-) OUT	Data 3.3 V, current-limited

RS-485 I/O

Terminal	Rating
	Ground for cable shield (if applicable)
(+), (-) IN	Reserved for future use.
(+), (-) OUT	Data 3.3 V, current-limited

The RS-485 I/O utilizes standard RS-485 signaling in multi-drop mode with 120 Ohm terminations.

Fire Routing Output 1

Reserved for future use.

Prog Inputs

Terminals	Rating
1, 2, 3	Supervision: None Open Circuit Voltage: 24 VDC Activation: Short to 0V terminal (< 100 ohms) Activation current: 3.3 mA typical

Fire Routing Input

Supervised input to receive confirmation signal from fire routing equipment. Reprogrammable for any input event type.

Terminals	Rating
(+), (-)	Supervision: Class B Open Circuit Voltage: 10V End-of-Line device: 3.3K Ohm resistor (S2063) Activation device: 680 Ohm resistor

Fire Routing Output 2

Reprogrammable for any output event type.

Terminals	Rating
(+), (-)	Regulated 24V DC @ 60 mA Fuse: Self-resetting Supervision: Reverse-polarity DC End-of-line device: Diode (S2029)

Prog Routing Input 1

Programmable for any input event type.

Terminals	Rating
(+), (-)	Supervision: Class B Open Circuit Voltage: 10V End-of-Line device: 3.3K Ohm resistor (S2063) Activation device: 680 Ohm resistor

Prog Routing Output

Terminals	Rating
(+), (-)	24V max. Impedance between (+) and (-) terminals measures 3.3K ohms when inactive. Impedance between (+) and (-) terminals measures 680 ohms when active.

Prog Routing Input 2

Programmable for any input event type.

Terminals	Rating
(+), (-)	Supervision: Class B Open Circuit Voltage: 10V End-of-Line device: 3.3K Ohm resistor (S2063) Activation device: 680 Ohm resistor

Trouble Routing Output

Reprogrammable for any output event type.

Terminals	Rating
(+), (-)	Regulated 24V DC @ 60 mA Fuse: Self-resetting Supervision: Load > 5 mA End-of-line device: 3.3K ohms if load < 5 mA

Trouble Routing Input

Reprogrammable for any input event type.

Terminals	Rating
(+), (-)	Supervision: Class B Open Circuit Voltage: 10V End-of-Line device: 3.3K Ohm resistor (S2063) Activation device: 680 Ohm resistor

System Information

Property	Description
Software Zones	2000 zone capacity
Software Groups	5000 group capacity
Event Log	10,000 event capacity, 1 second resolution. Filterable and printable.
Cause and Effects	5000

Mechanical

Fascia Components

Property	Description
Display	Full color 800 x 480 LCD with resistive touch screen and automatic backlight dimming
L@titude Printer	40 column, front loading thermal (optional)
Zone LED Indicators	Up to 3 banks of 48 (144) (optional)

Operating Environment

Dry indoor use only.

Temperature Range	23°F (-5°C) - 120°F (49°C)
Relative Humidity	Up to 95%, non-condensing

Cabinet Housing

Housing	Description
Dimensions	4 Slot Standard Cabinet - 420mm (W) x 590mm (H) x 153mm (D), approximately 16.5in (W) x 23.2in (H) x 6in (D)
	8 Slot Standard Cabinet - 540mm (W) x 720mm (H) x 160mm (D), approximately 21.3in (W) x 28.3in (H) x 6.3in (D)
	4 Slot Deep Cabinet - 420mm (W) x 590mm (H) x 203mm (D), approximately 16.5in (W) x 23.2in (H) x 8in (D)
	8 Slot Deep Cabinet - 540mm (W) x 720mm (H) x 212mm (D), approximately 21.3in (W) x 28.3in (H) x 8.3in (D)
Construction	Standard and Deep Cabinet Models
	These models include: <ul style="list-style-type: none"> • Mild sheet steel enclosure, 16 SWG • Removable equipment chassis • All epoxy powder coated • Knockouts top and back, one on each side • Hinged lid with single locks • Hinged bridge plates containing fascia indications • Optional printer
Finish	Epoxy powder coated
Color	Lid & Box - Red or Gray
	Control Plate - RAL7016
Cable Entry	Standard and Deep Cabinet Models - 28 knockouts top, 19 knockouts back, 1 knockout each side
Mounting	Minimum size #12, Maximum size #14. 40mm (1.5in.) length
Battery Capacity	2 to 8 Loop (4 slot) enclosure: Standard Cabinet - Up to 28 Ah (Power Sonic PS-12280) Deep Cabinet - Up to 40 Ah (Power Sonic PS-12400)
	2 to 16 Loop (8 slot) enclosure: Standard Cabinet - Up to 28 Ah (Power Sonic PS-12280) Deep Cabinet - Up to 40 Ah (Power Sonic PS-12400)

The following figures illustrate the FireNET L@titude Fire Alarm Control Panel cabinet housing options. All cabinets can be ordered with an optional second aperture to accommodate a printer or Fire In Zone LED indicators.

4 Slot Standard Enclosure

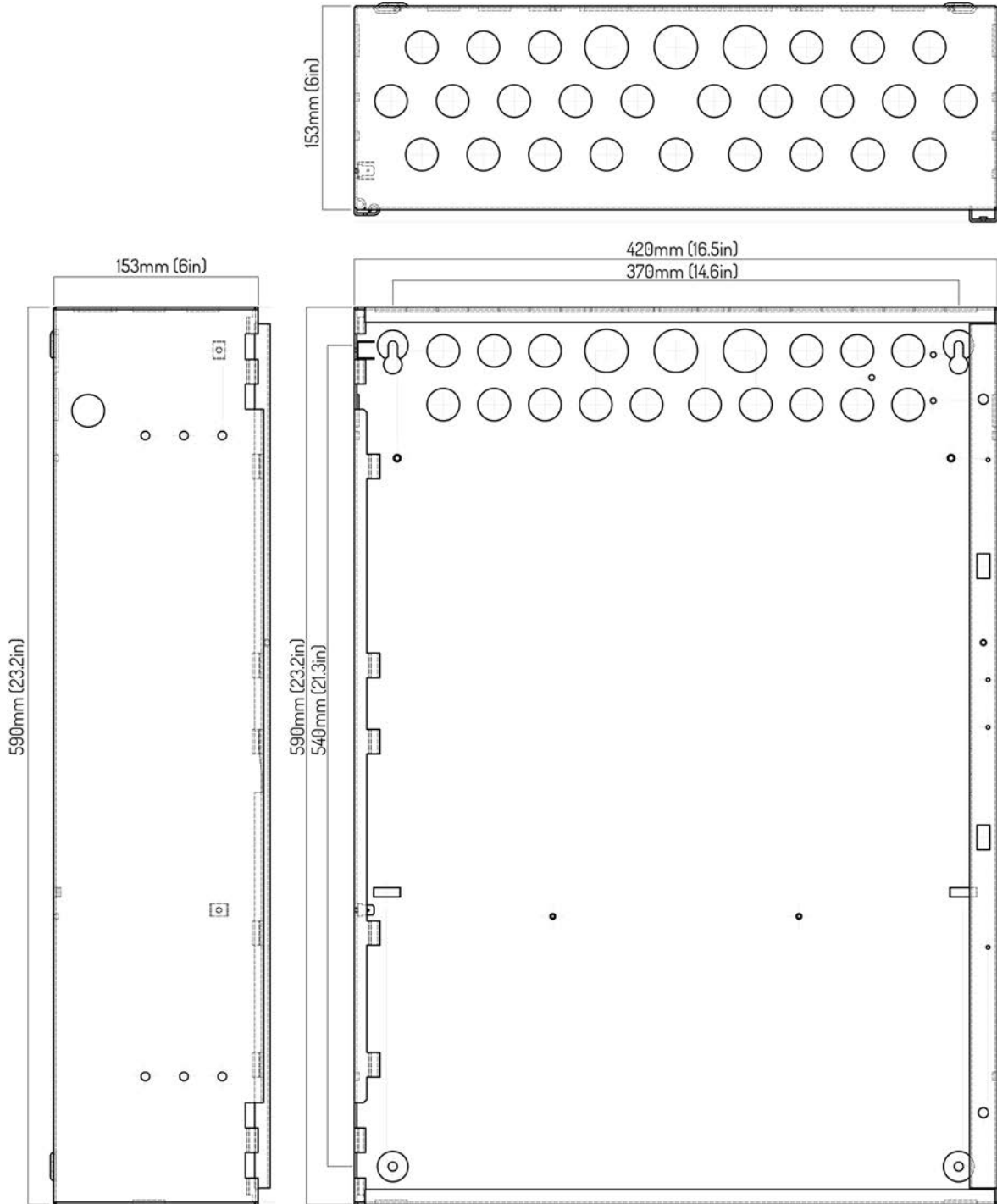

8 Slot Standard Enclosure

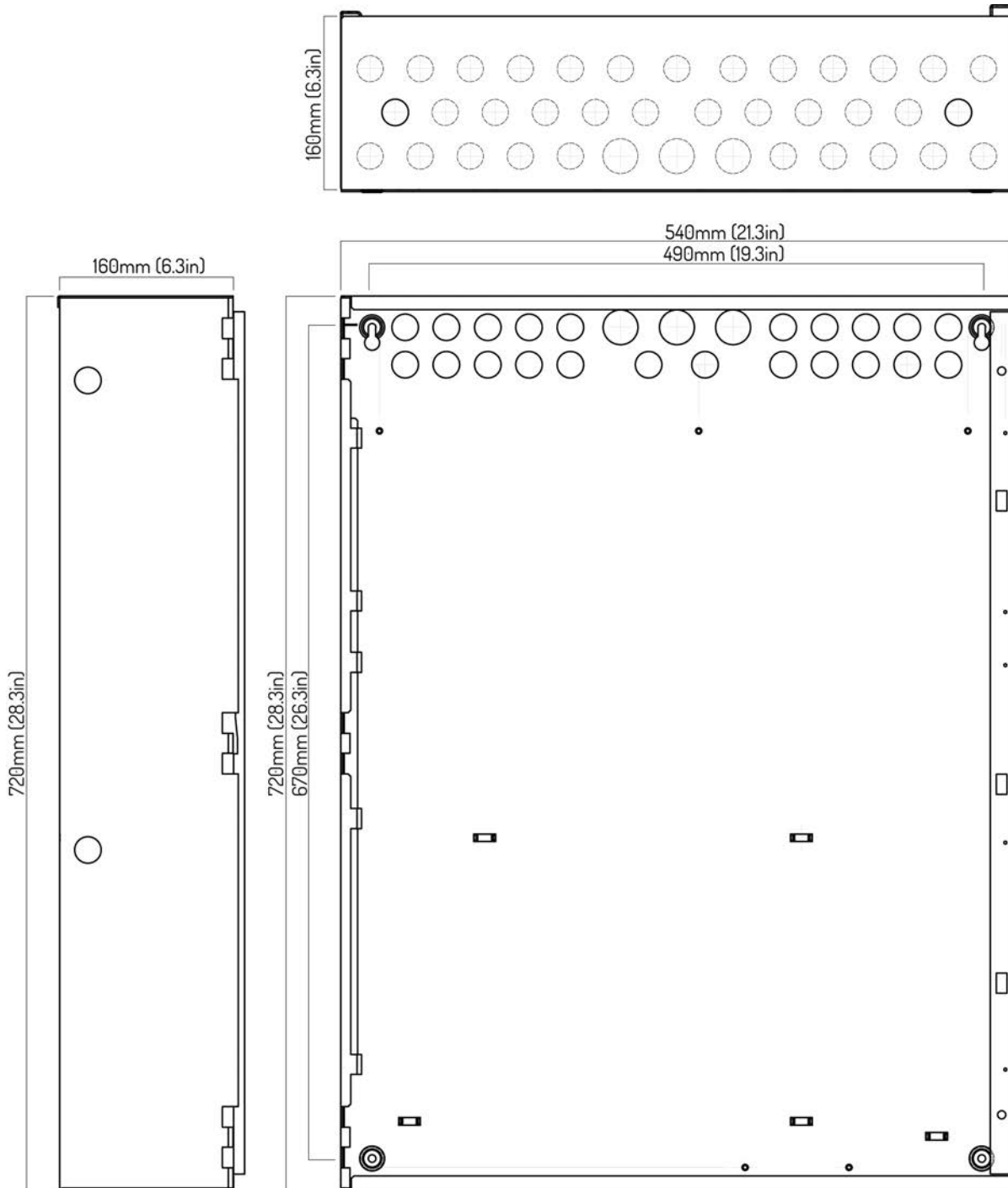

4 Slot Deep Enclosure

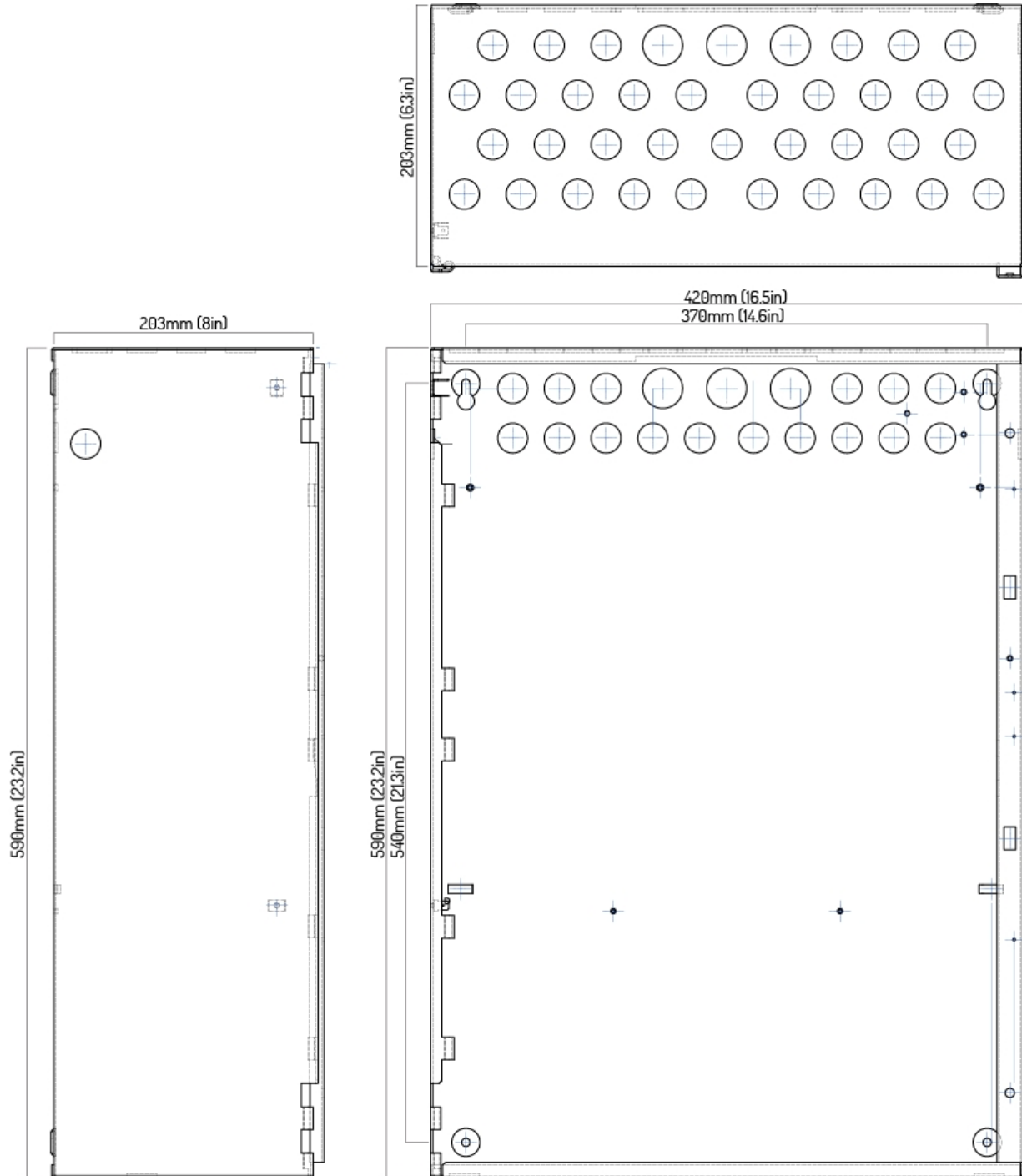

8 Slot Deep Enclosure

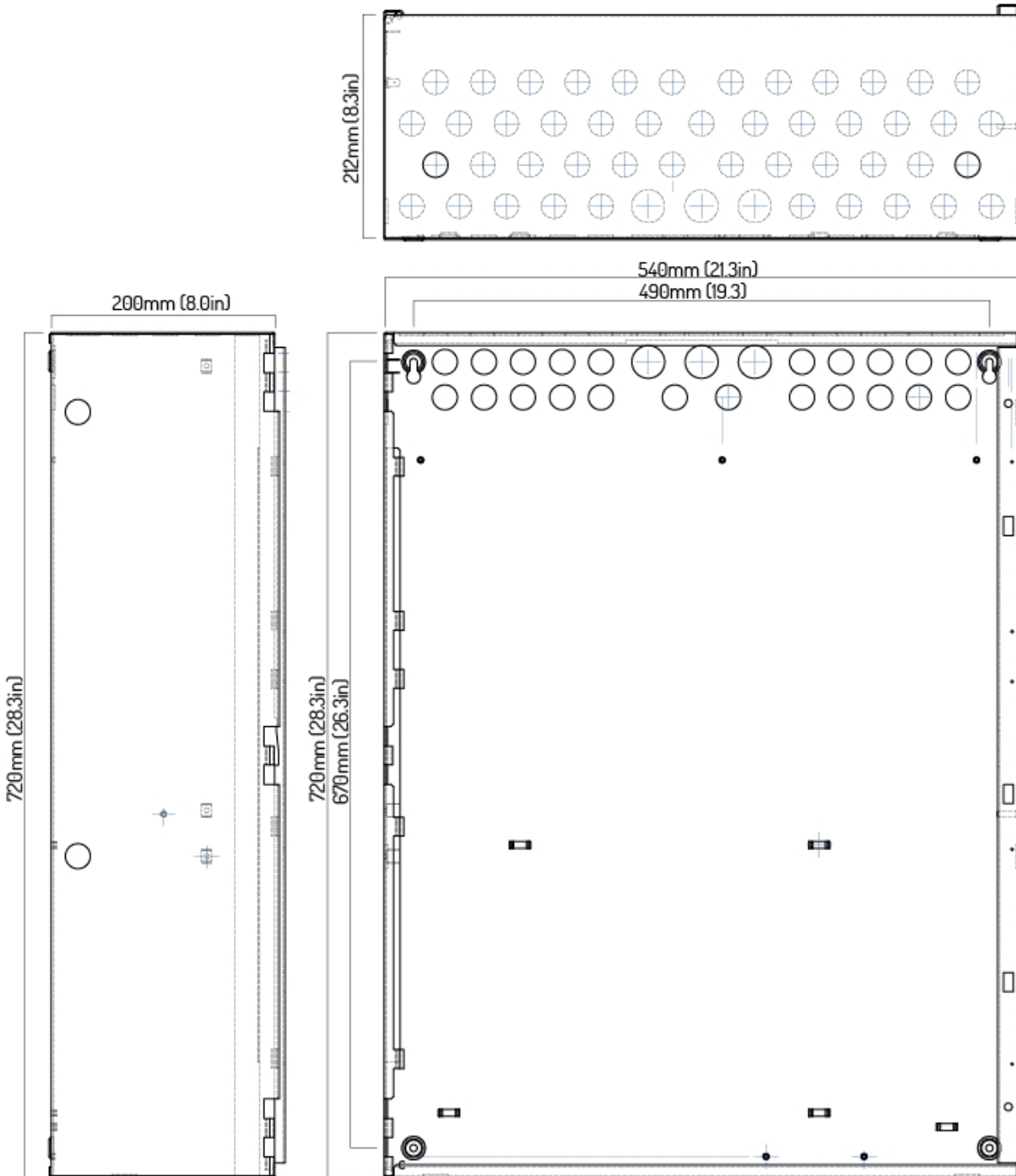

19" Rack Mount

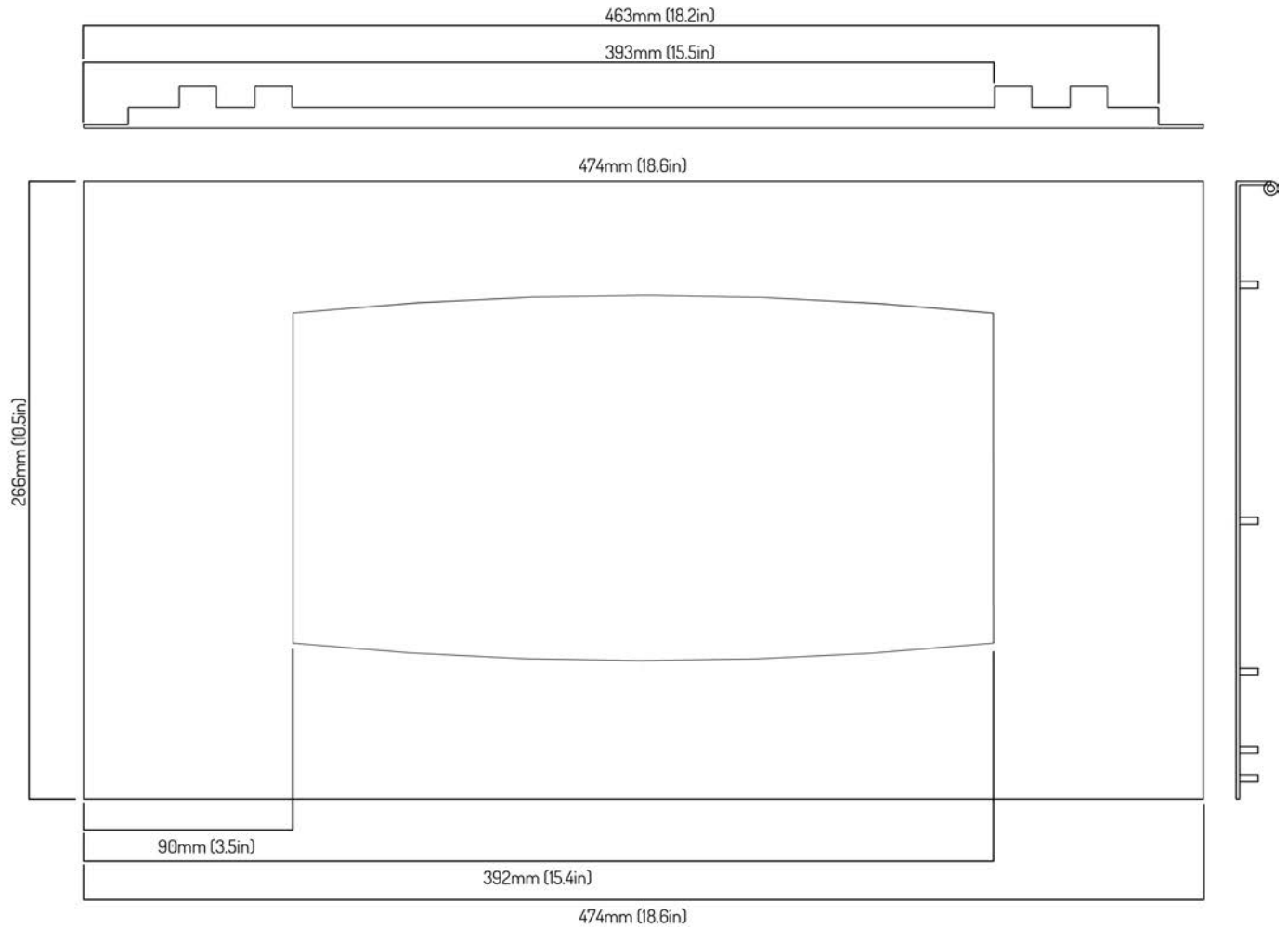

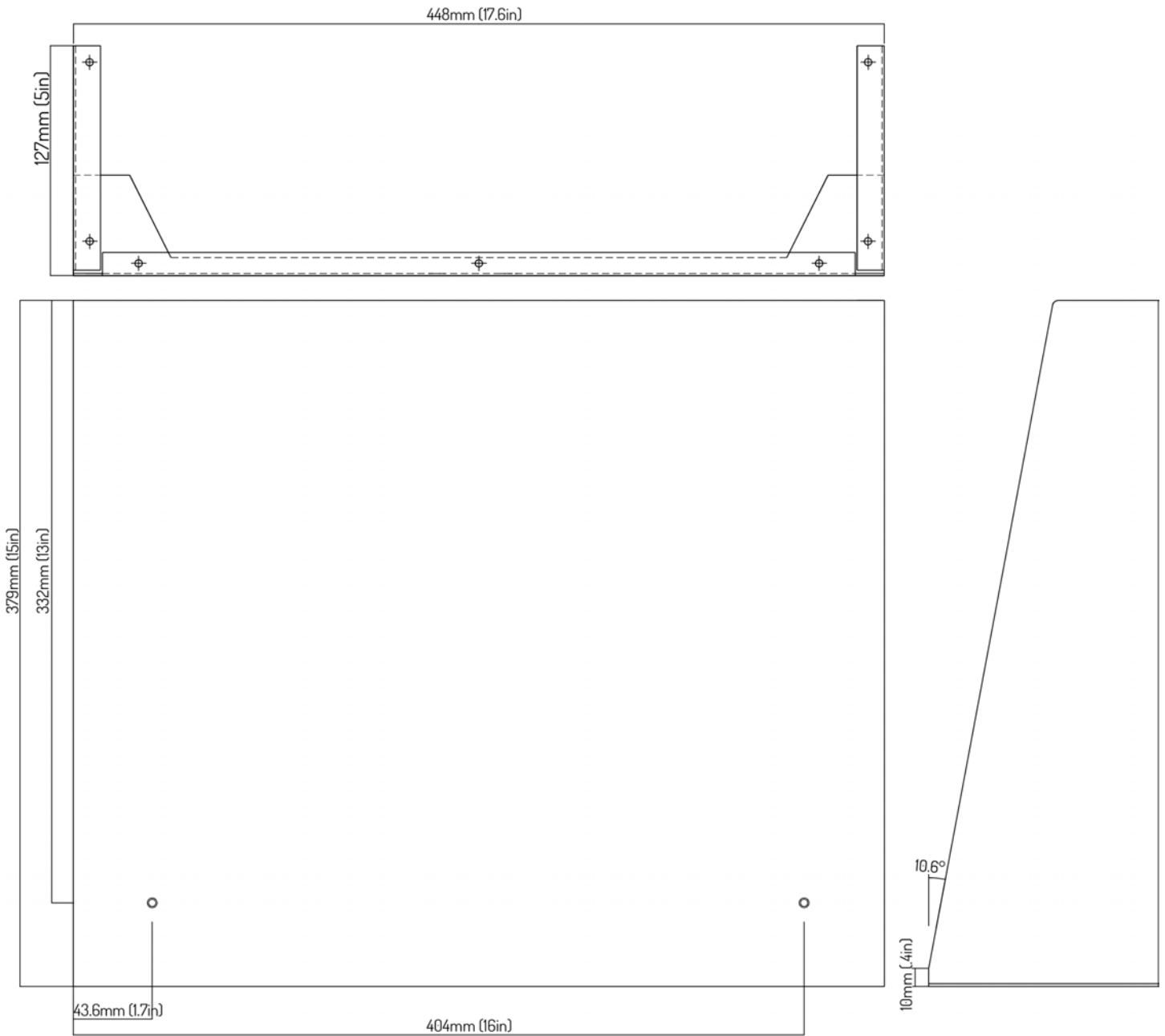

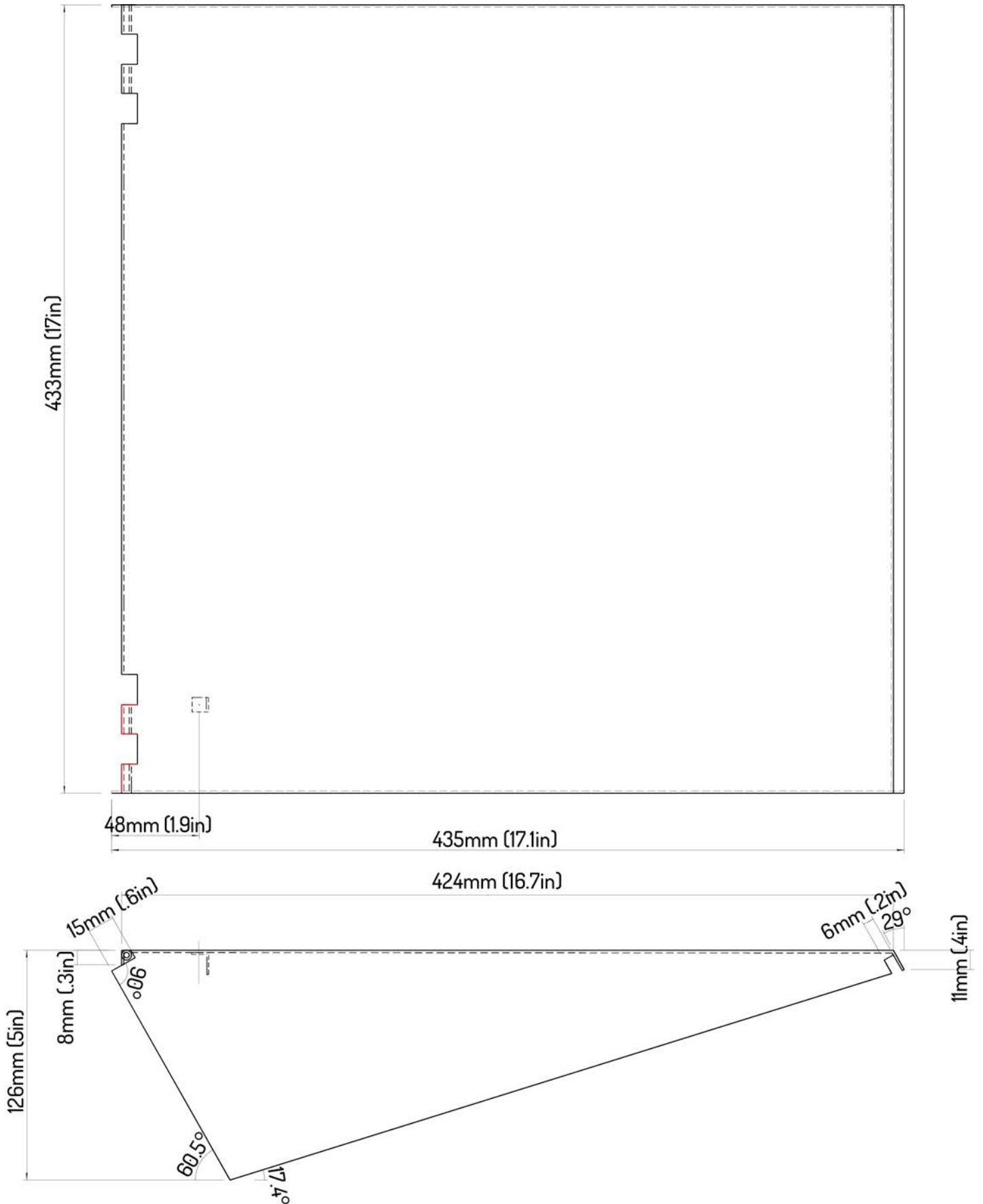

APPENDIX B: EQUIPMENT LIST

Panel Model Numbers

The following is a sample illustrating how to build a model number for the FireNET L@titude Fire Alarm Control Panel

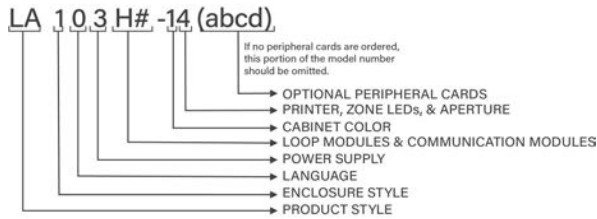

Option Ranges		
Panel Options	Valid Entries	Description
Product Style	LA	FireNET L@titude Fire Alarm Control Panel
	LF	FireNET L@titude Vision Annunciator
Enclosure Style	1	4 Slot Standard Enclosure
	2	4 Slot Standard Plex-Door Enclosure
	3	4 Slot Deep Enclosure
	4	4 Slot Deep Plex-Door Enclosure
	6	4 Slot 19" Rack Mount Enclosure
	7	8 Slot Standard Enclosure - 16 Loop
	8	8 Slot Standard Plex-Door Enclosure - 16 Loop
	9	8 Slot Deep Enclosure - 16 Loop
	A	8 Slot Deep Plex-Door Enclosure - 16 Loop
Language	C	Annunciator
	0	English
	1	Portuguese
	2	Spanish
	3	Taiwanese
Power Supply	0	None
	1	5.25 A 115V
	2	5.25 A 230V
Loop Modules & Communication Modules	3	10.25 A (auto-voltage sensing)
	00	Not Fitted
	NC	Network Module only (Network Vision Annunciator)
	H#	2-Loop Panel Module, Hochiki Protocol
	I#	2-Loop Panel Module, Hochiki Protocol, and Media Gateway™
J#	2-Loop Panel Module, Hochiki Protocol, and Network Module	
K#	2-Loop Panel Module, Hochiki Protocol, Network Module, and Media Gateway™	

Option Ranges		
Panel Options	Valid Entries	Description
Cabinet Color	1	Red (RAL3002)
	4	Gray (BS 00 A 0S)
	6	Black (RAL9005)
Printer, Zone LEDs & Aperture	0	No Printer / No Zone LEDs
	1	No Printer / No Zone LEDs, Blank 2nd Aperture
	3	Printer / No Zone LEDs
	4	Printer / 48 Zone LEDs
	5	No Printer / 48 Zone LEDs
	6	No Printer / 96 Zone LEDs
	7	No Printer / 144 Zone LEDs
Optional Peripheral Cards	a	16 Channel I/O Panel Module (S772)
	b	8 Channel Relay Panel Module (S791)
	c	8 Channel Conventional Zone Module (S792)
	d	4 Channel NAC Module (S793)

Replacement Parts

The following replacement parts are provided for the FireNET L@titude Fire Alarm Control Panel. All part quantities are “one” unless otherwise indicated in parentheses.

Models	Description
MAN-1431	FireNET L@titude Fire Alarm Control Panel - Installation Manual
S406	5.25 Amp Power Supply, 115 VAC / 230 VAC *
S408	10.25 Amp Power Supply, 115 VAC / 230 VAC *
S721	LCD Main Processor Board
S722	Main Back Board
S723	L@titude Network Module
S752	Power Supply Accessory Kit
S758	Dual Loop Panel Module
S768	L@titude Printer
S769	System A Panel Module
S770	System B Panel Module
S771	Zone LED Module
S787	L@titude Vision Unit
KB3472	Thermal Paper Rolls, 58 mm wide
SR1016	40 Conductor IDC Cable
SR1017	34 Conductor IDC Cable
SR1023	10 Conductor IDC Zone LED Cable
SR1020	14 Conductor IDC PSU Signal Cable
SR1024	10 Conductor IDC Zone LED to LED Cable
SR1018	10 Conductor IDC Printer Cable
SKW91BLACK	PSU Power 0V Cable
SKW91RED	PSU Power 24V Cable
S2028-6	Resistor Kit (6) 10K Ohm, EOL
S2028	Resistor 10K, EOL
S2063-4	Resistor Kit (4) 3.3 K Ohm, EOL
S2063	Resistor 3.3 K Ohm, EOL
S2029	EOL Diode
S007	Panel Key Lock Set
B3532	Panel Cabinet Lock
B1828	Key Switch
M117	Hinge Pins (Long)

Models	Description
M118	Hinge Pins (Short)
B3744	Panel Grounding Block
K14070	End of Line Device for Municipal Box
K1514-00	Battery Lead Set with fuse holder and 10A 3AG fuse for 5.25A power supply

* Power Supplies are required components of the FireNET L@titude Fire Alarm Control Panel.

Accessories

Model Number	Devices
SP512A-R3	CAT5e Surge Protector, manufactured by Black Box
VF1155-00	Multi-mode Fiber Converter TCF-142M-ST
VF1156-00	Multi-mode Fiber Converter TCF-142M-SC
VF1157-00	Single-mode Fiber Converter TCF-142S-ST
VF1158-00	Single-mode Fiber Converter TCF-142S-SC

Loop Devices

The following Hochiki-Protocol loop devices and accessories are authorized for use with the FireNET L@titude Fire Alarm Control panel:

VES Models	Hochiki Models	Loop Device Description
VF2008-00	ACA-V	Multi-Criteria Detector Smoke/Heat
VF2012-00	ACC-V	Multi-Criteria Detector Smoke/Heat
VF2014-00	ACD-V	Multi-Criteria Detector - Smoke/Heat/CO
VF2001-00	AIE-EA	Smoke Detector - Ionization
VF2004-00	ALG-DH	Smoke Detector - Photoelectric for use with DH-98-A/DH-98-AR
	ALN-DH	Smoke Detector - Photoelectric for use with DH-100-A
VF2002-00	ALG-V	Smoke Detector - Photoelectric
VF2005-00	ALK-V	Smoke Detector - Photoelectric
VF2011-00	ALN-V	Smoke Detector - Photoelectric
	ALO-V	Smoke Detector - Photoelectric**
VF3031-10	AMS	Addressable Manual Pull Station - Single-Action, Hex Key
VF3032-10	AMS-KL	Addressable Manual Pull Station - Single-Action w/ Cat 30 Key
VF3029-10	AMS-KL-LP	Addressable Manual Pull Station - Dual-Action w/ Cat 30 Key
VF3030-10	AMS-LP	Addressable Manual Pull Station - Dual-Action, Hex Key
VF7008-00	ASB	Sounder Base - Aux Power *
VF7005-00	ASBL	Sounder Base - Low Frequency, Aux Power *
	ASB7	Sounder base - Aux Power, 7th Edition
	ASBL7	Low Frequency Sounder base - Aux Power, 7th Edition
VF2003-00	ATG-EA	Heat Detector - Fixed Temp
VF2010-00	ATJ-EA	Heat Detector - Fixed Temp, Rate of Rise
VF6011-00	CZM	Conventional Zone Module
	DH-100-A	Duct Smoke Detector - ALN
VF5013-00	DH-99-A	Duct Smoke Detector - ALK
VF5014-00	DH-99-AR	Duct Smoke Detector - ALK, Relays
VF5001-00	DH-98-A	Duct Smoke Detector - ALG
VF5002-00	DH-98-AR	Duct Smoke Detector - ALG, Relays
VF6007-00	DIMM	Dual Contact Module - 4" Cover Plate
VF6020-00	FRCMA	Contact Module - Class A
VF6021-00	FRCMA-I	Contact Module - Class A, Short Circuit Isolator
VF6022-00	FRCMA-P	Contact Module - Class A, Pigtails
VF6023-00	FRCMA-PI	Contact Module - Class A, Pigtails & Short Circuit Isolator
VF6002-00	FRCME-4	Contact Module - 4" Cover Plate

VES Models	Hochiki Models	Loop Device Description
VF6024-00	FRCME-M	Contact Module - Terminals, Miniature
VF6022-00	FRCME-P	Contact Module - Pigtailed
VF6001-00	FRCME-S	Contact Module - Terminals
VF7002-00	HSB-NSA-6	Detector Base 6"
	HSB-NSA-67	Detector Base 6" - 7th Edition
VF5023-00	MS-KA/R	Remote Test Station for Duct Detectors - Alarm LED w/ Reset Key Switch
VF5020-00	MS-RA	Remote Test Station for Duct Detectors - Alarm LED
VF5021-00	MS-RA/R	Remote Test Station for Duct Detectors - Alarm LED w/ Reset Button
VF6005-00	R2M	Dual Relay Module - 1A @ 30 VDC / 0.5A @ 120 VAC
VF6054-00	R2MH	Dual Relay Module - 8A @ 30 VDC / 4.8A @ 250 VAC
VF6055-00	R2MH-I	Dual Relay Module - 8A @ 30 VDC / 4.8A @ 250 VAC, Isolator
VF6052-00	R2ML	Dual Relay Module - 2A @ 30 VDC / 0.5A @ 120 VAC
VF6053-00	R2ML-I	Dual Relay Module - 2A @ 30 VDC / 0.5A @ 120 VAC, Isolator
VF6003-00	SCI	Short Circuit Isolator Module
VF7003-00	SCI-B4	Short Circuit Isolator Base 4"
VF7004-00	SCI-B6	Short Circuit Isolator Base 6"
	SCI-B47	Short Circuit Isolator Base 4" - 7th Edition
	SCI-B67	Short Circuit Isolator Base 6" - 7th Edition
VF3001-00	SG-32BK2-VG-B	Addressable Pull Station - Single-Action
VF3002-00	SG-32BK1-VG-B	Addressable Pull Station - Dual-Action
VF6004-00	SOM	Supervised Output Module
VF6040-00	SOM-A	Supervised Output Module - Class A
VF6041-00	SOM-AI	Supervised Output Module - Class A, Short Circuit Isolator
VF6043-00	SOM-R	Supervised Output Module Release w/ Disable Keyswitch
VF7001-00	YBN-NSA-4	Detector Base 4"
	YBN-NSA-47	Detector Base 4" - 7th Edition
VF9000-00	TCH-B100	Handheld Programmer

* Sounder bases in different zones should not be powered from the same power circuit. Refer to UL864, 10th edition, sections 56.1.7, 56.3.3, and 56.4.2 – 56.4.4.

** ALO-V is not compatible with 6th Edition bases.

The following Silent Knight Protocol loop devices and accessories are authorized for use with the FireNET L@titude Fire Alarm Control panel:

VES Models	Silent Knight Models	Loop Device Description
	SD505-AIS	Smoke Detector - Ionization
	SD505-APS	Smoke Detector - Photoelectric
	SD505-PHOTO	Smoke Detector - Photoelectric
	SD505-AHS	Heat Detector
	SD505-HEAT	Heat Detector
	SD505-6AB	Detector Base 6"
	SD505-4AB	Detector Base 4"
	SD505-DUCT	Duct Detector
	SD505-DUCTR	Duct Detector w/Relay
	SD505-DTS-K	Remote Test Switch

Special Application NAC Outputs

Amseco Compatible NAC Devices

The following series of Amseco NAC devices are compatible for use on the special application outputs of NACs when these outputs are configured for Amseco synchronization protocol.

Name of Series	Environment	Model	Description	Mount
Select-A-Strobe/Chime	Indoor	CM24C	Chime	Ceiling
Select-A-Strobe/Chime	Indoor	SCM24C	Chime Strobe	Ceiling
Select-A-Horn	Indoor/Outdoor	H-1224	Horn	Wall
Select-A-Strobe/Horn	Indoor	SH-1224	Horn Strobe	Wall
Select-A-Strobe/Horn	Outdoor	SH-1224WP	Horn Strobe	Wall
Select-A-Strobe/Horn	Indoor	SH24C-177	Horn Strobe	Wall/Ceiling
Select-A-Strobe/Horn	Indoor	SH24C-3075110	Horn Strobe	Wall/Ceiling
Speaker/Strobe Square	Indoor/Outdoor	SSS-2	Speaker Strobe	Wall
Speaker/Strobe Square	Indoor/Outdoor	SSS-8	Speaker Strobe	Wall
Speaker/Strobe Round	Indoor/Outdoor	SSR-2	Speaker Strobe	Wall/Ceiling
Speaker/Strobe Round	Indoor/Outdoor	SSR-8	Speaker Strobe	Wall/Ceiling
Speaker/Strobe Round	Indoor	SSC-2	Speaker Strobe	Wall/Ceiling
Speaker/Strobe Round	Indoor	SSC-8	Speaker Strobe	Wall/Ceiling
Select-A-Strobe	Indoor	SL-1224	Strobe	Wall
Select-A-Strobe	Indoor/Outdoor	SL-1224-WP	Strobe	Wall
Select-A-Strobe	Indoor	SL24C-3075110	Strobe	Wall/Ceiling
Select-A-Strobe	Indoor	SL24C-177	Strobe	Wall/Ceiling
Bell/Select-A-Strobe	Indoor	SB24	Bell Strobe	Wall/Ceiling
Select-A-Strobe/Chime	Indoor	SCM24W-153075	Chime Strobe	Wall
Select-A-Strobe/Chime	Indoor	SCM24W-75110	Chime Strobe	Wall
Select-A-Horn	Indoor	H24W	Horn	Wall/Ceiling
Select-A-Strobe/Horn	Indoor	SH24W-1530	Horn Strobe	Wall
Select-A-Strobe/Horn	Indoor	SH24W-75110	Horn Strobe	Wall
Indoor/Outdoor Horn/Strobe	Indoor/Outdoor	SHB24-75	Horn Strobe	Wall
Speaker/Strobe	Indoor	SSC25-177	Speaker Strobe	Wall/Ceiling
Select-A-Strobe/Speaker	Indoor	SSC25-3075110	Speaker Strobe	Wall/Ceiling
Speaker/Strobe	Indoor	SSC70-177	Speaker Strobe	Wall/Ceiling
Select-A-Strobe/Speaker	Indoor	SSC70-3075110	Speaker Strobe	Wall/Ceiling
Select-A-Strobe/Speaker	Indoor	SFH45-153075	Speaker Strobe	Wall/Ceiling

Name of Series	Environment	Model	Description	Mount
Select-A-Strobe/Speaker	Indoor	SFH47-75110	Speaker Strobe	Wall/Ceiling
Select-A-Strobe	Indoor	SL24W-1530	Strobe	Wall
Select-A-Strobe	Indoor	SL24W-75110	Strobe	Wall
Indoor/Outdoor Strobe	Indoor/Outdoor	SLB24-75	Strobe	Wall
Select-A-Strobe	Indoor/Outdoor	SB24	Strobe	Wall/Ceiling
Select-A-Strobe/Horn	Indoor	SH24W-153075	Horn Strobe	Wall
Select-A-Strobe	Indoor	SL24W-153075	Strobe	Wall
Select-A-Strobe	Indoor	ASH-2475110R	Horn Strobe	Wall
Select-A-Strobe	Indoor	RSB24-153075	Strobe	Wall/Ceiling
Select-A-Strobe	Indoor	RSD24-153075	Strobe	Wall/Ceiling
Select-A-Strobe	Indoor	RSD24-75110	Strobe	Wall/Ceiling
Select-A-Strobe	Indoor	SA24 SERIES	Strobe	Wall
Select-A-Strobe	Indoor	SAD24-153075	Strobe	Wall/Ceiling
Select-A-Strobe	Indoor	SAD24-75110	Strobe	Wall

Gentex Compatible NAC Devices

The following series of Gentex NAC devices are compatible for use on the special application outputs of NACs when these outputs are configured for Gentex synchronization protocol.

Model	Description
GCC24	Indoor Horn Strobe, Ceiling
GCC24CR	Horn/Strobe, Ceiling Red Multi-Candela (GCC)
GCC24CW	Horn/Strobe, Ceiling White Multi-Candela (GCC)
GCS24	Indoor Strobe, Ceiling
GCS24CR	Strobe, Ceiling Red Multi-Candela (GCS)
GCS24CW	Strobe, Ceiling White Multi-Candela (GCS)
GEC3-24	Indoor Horn Strobe, Wall
GEC3-24WR	Horn/Strobe, Wall Red Multi-Candela (GEC3)
GEC3-24WW	Horn/Strobe, Wall White Multi-Candela (GEC3)
GEC24	Indoor Horn Strobe, Wall
GEH24	Indoor / Outdoor Horn
GES3-24	Indoor Strobe, Wall
GES3-24WR	Strobe, Wall Red Multi-Candela (GES3)
GES3-24WW	Strobe, Wall White Multi-Candela (GES3)
GES24	Indoor Strobe, Wall
GX93	Indoor Mini Horn, Wall

Model	Description
SSPK24CLP	Indoor Speaker Strobe, Ceiling
SSPK24WLP	Indoor Speaker Strobe, Wall
WGEC24-75WR	Weatherproof Horn/Strobe (Gentex) Red
WGEC24	Outdoor Horn Strobe, Wall
WGES24	Outdoor Strobe, Wall
WSSPK24-15/75	Outdoor Speaker Strobe, Wall

Gentex model numbers preceded by 'H' are Hochiki multiple-listed versions.

System Sensor Compatible NAC Devices

The following series of System Sensor NAC devices are compatible for use on the special application outputs of NACs when these outputs are configured for System Sensor synchronization protocol.

Name of Series	Environment	Model	Series Description	Mount
SpectrAlert Advance	Indoor	SPS	Speaker Strobe	Wall
SpectrAlert Advance	Indoor	SPSC	Speaker Strobe	Ceiling
SpectrAlert Advance	Outdoor	SPS (K)	Speaker Strobe	Wall
SpectrAlert Advance	Outdoor	SPSC (K)	Speaker Strobe	Ceiling
SpectrAlert Advance	Indoor	P2	Horn Strobe, 2-Wire	Wall
SpectrAlert Advance	Indoor	P4	Horn Strobe, 4-Wire	Wall
SpectrAlert Advance	Indoor	S	Strobe	Wall
SpectrAlert Advance	Indoor	PC2	Horn Strobe, 2-Wire	Ceiling
SpectrAlert Advance	Indoor	PC4	Horn Strobe, 4-Wire	Ceiling
SpectrAlert Advance	Indoor	SC	Strobe	Ceiling
SpectrAlert Advance	Indoor	H	Horn	Wall/Ceiling
SpectrAlert Advance	Outdoor	P2 (K)	Horn Strobe, 2-Wire	Wall
SpectrAlert Advance	Outdoor	P4 (K)	Horn Strobe, 4-Wire	Wall
SpectrAlert Advance	Outdoor	S (K)	Strobe	Wall
SpectrAlert Advance	Outdoor	PC2 (K)	Horn Strobe, 2-Wire	Ceiling
SpectrAlert Advance	Outdoor	PC4 (K)	Horn Strobe, 4-Wire	Ceiling
SpectrAlert Advance	Outdoor	SC (K)	Strobe	Ceiling
SpectrAlert Advance	Outdoor	H (K)	Horn	Wall/Ceiling
SpectrAlert Advance	Indoor	CH	Chime	Wall/Ceiling
SpectrAlert Advance	Indoor	CHS	Chime Strobe	Wall
SpectrAlert	Indoor	CH24MC	Chime Strobe	Wall
SpectrAlert	Indoor	CH1224	Chime	Wall/Ceiling
SpectrAlert	Indoor	SP2x1224MC	Speaker Strobe	Wall

Name of Series	Environment	Model	Series Description	Mount
SpectrAlert	Indoor	SP3x1224MC	Speaker Strobe	Wall
SpectrAlert	Outdoor	SP2R1224MCK	Speaker Strobe	Wall
SpectrAlert		S1224MC	Strobe	Wall
SpectrAlert		P1224MC	Horn Strobe, 4-Wire	Wall
SpectrAlert		H12/24	Horn	Wall/Ceiling

Wheelock Compatible NAC Devices

The following series of Wheelock NAC devices are compatible for use on the outputs of NACs when these outputs are configured for Wheelock synchronization protocol.

Model Number Series	Description
AH-24-R	Horn, Red (AH)
AH-24-W	Horn, White (AH)
AH-24WP-R	Weatherproof Horn, Red (AH)
AH-12, AH-24	Audible
AHWP	Audible - outdoor
AMT-241575	Mutilating Strobe (NYC) - 1575 cd, Wall
AMT-241575, AMT-24MCW	Mutilating Strobe - 1575cd or 15,30,75,110 cd, Wall
AMT-241575W-FR	Audible Multitone /Strobe Red 15/75cd
AMT-2475W-FR	Audible Multitone /Strobe Red 75cd
AMT-12/24-R	Audible Multitone Addressable Red
AMT-12/24-W	Audible Multitone Addressable White
AMT-12/24	Mutilating - 3 inputs
AMT-12/24 Audible Only	Mutilating Audible only
AS-241575W-FR	Audible Strobe Wall Mounted Red 15/75cd
AS-241575W-FW	Audible Strobe Wall Mounted White 15/75cd
AS-241575W-FW	Audible/Strobe Wall Mounted White 15/75cd
AS-121575, AS-241575	Audible Strobe - 1575 cd, Wall
AS-24MCC	Audible Strobe - 15,30,75,95 cd, Ceiling
AS-24MCC-FR	Horn/Strobe, Ceiling, Multi-Candela, Red (AS)
AS-24MCC-FW	Horn/Strobe, Ceiling, Multi-Candela, White (AS)
AS-24MCCH	Audible Strobe - 115,177 cd, Ceiling
AS-24MCCH-FR	Horn/Strobe, Ceiling, 115/177, Red (AS)
AS-24MCCH-FW	Horn/Strobe, Ceiling, 115/177, Red (AS)
AS-24MCW	Audible Strobe - 15,30,75,110 cd, Wall
AS-24MCW-FR	Horn/Strobe, Wall, Multi-Candela, Red (AS)

Model Number Series	Description
AS-24MCW-FW	Horn/Strobe, Wall, Multi-Candela, White (AS)
AS-24MCWH	Audible Strobe - 135,185 cd, Wall
AS-24MCWH-FR	Horn/Strobe, Wall, 135/185, Red (AS)
AS-24MCWH-FW	Horn/Strobe, Wall, 135/185, White (AS)
ASWP-2475	Audible Strobe - 180 cd, weatherproof
ASWP-2475W-FR	Weatherproof Horn/Strobe, Red (AS)
CH90-24-W	Chime Round, White
CH90-24MCC	Chime - 15,30,75,95 cd, Ceiling
CH90-24MCC-FR	Chime/Strobe, Ceiling, Multi-Candela, Red (CH)
CH90-24MCC-FW	Chime/Strobe, Ceiling, Multi-Candela, White (CH)
CH90-24MCCH-FW	Chime/Strobe White Round 15/30/75/95 cd
CH90-2475C-FW	Chime/Strobe Round White 75cd
CH90-24100C-FW	Chime/Strobe Round White 100cd
CH90-MCCH	Chime - 115,177 cd, Ceiling
CH70-241575-FR	Chime/Strobe Square Red 15/75cd
CH70-24-R	Chime Square, Red
CH70-24-W	Chime Square, White
CH70-24MCW	Chime - 15,30,75,110 cd, Wall
CH70-24MCW-FR	Chime/Strobe, Wall, Multi-Candela, Red (CH)
CH70-24MCWH-FR	Chime/Strobe Red Wall 135/185 cd
CH70-24MCWH-FW	Chime/Strobe White Wall 135/185 cd
CH70-241575	Chime - 1575 cd, Wall
CH70-241575W-FW	Chime/Strobe Square White 15/75cd
CH70-MCWH	Chime - 135,185 cd, Wall
CH70, CH90	Chime
CJ70-24MCW-FW	Chime/Strobe, Wall, Multi-Candela, White (CH)
E90-24MCC	Speaker Strobe - 15,30,75,95 cd, Ceiling
E90-24MCC-FR	Speaker/Strobe Round 2 watt Multi-Candela 15/30/75/110 Red
E90-24MCCH	Speaker Strobe - 115,177 cd, Ceiling
E90-24MCCh-FW	Speaker/Strobe Ceiling White 115/177 cd
E90-254MCC-FW	Speaker/Strobe Round 2 watt Multi-Candela 15/30/75/110
E70-24MCW	Speaker Strobe - 15,30,75,110 cd, Wall
E70-24MCW-FR	Speaker/Strobe, Wall, Multi-Candela, Red (E Series)
E70-24MCW-FW	Speaker/Strobe, Wall, Multi-Candela, White (E Series)
E70-24MCWH	Speaker Strobe - 135,185 cd, Wall
E70-24MCWH-FR	Speaker/Strobe, Wall, 135/185, Red (E Series)

Model Number Series	Description
E70-24MCWH-FW	Speaker/Strobe, Wall, 135/185, White (E Series)
E70-241575	Speaker Strobe - 1575 cd, Wall
E70-241575W-FR	Speaker/Strobe Square 2 watt Red 15/75cd
E70-241575W-FW	Speaker/Strobe Square 2 watt White 15/75cd
E60-24MCC	Speaker Strobe 15,30,75,95 cd, Ceiling
E60-24MCC-FW	Speaker/Strobe Ceiling Mount 2 Watt Multi-Candela White
E60-24MCCH-FR	Speaker/Strobe Ceiling Mount 2 Watt High Multi-Candela Red
E60-24MCCH-FW	Speaker/Strobe Ceiling Mount 2 Watt High Multi-Candela White
E60-MCC-FR	Speaker/Strobe Ceiling Mount 2 Watt Multi-Candela Red
E60-MCCH	Speaker Strobe 115/177 cd, Ceiling
E50-24MCW-FR	Speaker/Strobe Wall Mount 2 Watt Multi-Candela Red
E50-24MCW-FW	Speaker/Strobe Wall Mount 2 Watt Multi-Candela White
E50-24MCWH-FR	Speaker/Strobe Wall Mount 2 Watt High Multi-Candela Red
E50-24MCWH-FW	Speaker/Strobe Sq. 2 Watt Multi-Candela White 135/185
E50-241575W	Speaker Strobe-Wall
E50-241575W-FR	Speaker/Strobe Square 2 Watt Red 15/75cd
E50-241575W-FW	Speaker/Strobe Square 2 Watt White 15/75cd
E50-MCW	Speaker Strobe - 15,30,75,110 cd, Wall
E50-MCWH	Speaker Strobe - 135,185 cd, Wall
E70A, E70B, E90A, E90B	Speaker Strobe - amber or blue lens
ET-1080-IS-24-V	Speaker/Strobe Vandal Proof 8 watt Flush White 75cd
ET-1080-LS-24-V	Speaker/Strobe Vandal-Proof 8 Watt Flush White 15cd
ET-1080-LS-24-V	Speaker/Strobe Vandal-Proof 8 Watt Flush Red 15cd
ET-1080-LSM-24-	Speaker/Strobe Vandal Proof 8 Watt Flush White 15/75cd
ET-1080-LSM-24-	Speaker/Strobe Vandal-Proof 8 Watt Flush Red 15/75cd
ET-1080-MS-24-V	Speaker/Strobe Vandal Proof 8 Watt Flush White 30cd
ET-1080-MS-24-V	Speaker/Strobe Vandal Proof 8 Watt Flush Red 30cd
ET-1080-SLM-24-	Speaker/Strobe Vandal Proof 8 watt Flush White 15/75cd
ET-1080-SLM-24-	Speaker/Strobe Vandal Proof 8 watt Flush Red 15/75cd
ET-108-IS-24-VF	Speaker/Strobe Vandal Proof 8 watt Flush Red 75cd
ET90-24MCC	Speaker Strobe - 15, 30, 75, 95 cd, Ceiling
ET90-24MCC-FW	Speaker/Strobe, Ceiling, Multi-Candela, Red (ET Series)
ET90-24MCCH	Speaker Strobe - 115, 177 cd, Ceiling
ET90-24MCCH-FW	Speaker/Strobe White Ceiling 8 Watt 115/177 cd
ET90-24150C-FW	Speaker/Strobe Round 8 Watt White 150cd
ET90-24177C-FW	Speaker/Strobe Round 8 watt White 177cd

Model Number Series	Description
ET80-24MCW	Speaker Strobe - Vandal resist, 15, 30, 75, 110 cd, Wall
ET80-24MCWH	Speaker Strobe - Vandal resist, 135, 185 cd, Wall
ET70-24MCW	Speaker Strobe - 15, 30, 75, 110 cd, Wall
ET70-24MCW-FR	Speaker/Strobe, Wall, Multi-Candela, Red (ET Series)
ET70-24MCW-FW	Speaker/Strobe, Wall, Multi-Candela, White (ET Series)
ET70-24MCWH	Speaker Strobe - 135, 185 cd, Wall
ET70-24MCWH-FR	Speaker/Strobe Wall Red 135/185 cd
ET70-24MCWH-FW	Speaker/Strobe Wall White 135/185 cd
ET70-241575	Speaker Strobe - 1575 cd, Wall
ET70-241575W-FW	Speaker/Strobe Square 8 watt White 15/75cd
ET7-241575W-FR	Speaker/Strobe Square 8 watt Red 15/75cd
ET70WP-2475	Speaker Strobe - Weatherproof
ET70WP-2475W-FR	Weatherproof Speaker Strobe, Wall
HNR	Exceder Horn - Red / Wall Mount
HNRC	Exceder Horn - Red / Ceiling Mount
HNW	Exceder Horn - White / Wall Mount
HNWC	Exceder Horn - White / Ceiling Mount
HNx	Audible, Wall
HNxC	Audible, Ceiling
HS-24	Audible
HS4-24MCW	Audible Strobe - 15, 30, 75, 110 cd, Wall
HS4-24MCW-FR	Horn/Strobe 4-Wire, Multi-Candela, Red (NS)
HS4-24MCW-FW	Horn/Strobe 4-Wire, Multi-Candela, White (NS)
HS4-24MCWH	Audible Strobe - 135, 185 cd, Wall
HS4-24MCWH-FR	Horn/Strobe Wall 4 Wire Red 135/185 cd
HS4-24MCWH-FW	Horn/Strobe Wall 4 Wire White 135/185 cd
HS4-241575	Audible Strobe - 15, 75 cd, Wall
HSR	Exceder Multi-Candela Horn / Strobe Red Wall Mount
HSRC	Exceder Multi-Candela Horn / Strobe Ceiling Mount Red
HSW	Exceder Multi-Candela Horn / Strobe White Wall Mount
HSWC	Exceder Multi-Candela Horn / Strobe Ceiling Mount White
HSx	Audible Strobe - 15, 15/75, 30, 75, 95, 110, 135, 185 cd, Wall
HSxC	Audible Strobe - 15, 30, 60, 75, 95, 115, 150, 177 cd, Ceiling
MIZ-24S	Mini Horn - Continuous, code-3, sync
MIZ-24S-R	Mini Horn, Red
MIZ-24S-W	Mini Horn, White

Model Number Series	Description
MT	Multi-tone
MT-241575W-FR	Audible Multitone Strobe Flush Red 15/75cd
MT-121575, MT-241575, MT-24MCW	Multi-tone Strobe - 1575 cd or 15,30,75,110 cd, Wall
MT-2475W-FR	Audible Multitone Strobe Flush Red 75cd
MT-12/24-R	Multi-Tone Flush Red
MT-12/24-W	Multi-Tone Flush White
MTWP-2475	Multi-tone Strobe - Weatherproof
MTWP-2475W-FR	Audible Multitone Strobe Weatherproof Red 75cd
MTWP B or A	Multi-tone Strobe - Weatherproof - Blue or Amber Lens
NH	Audible
NH-12/24-R	Horn, Red (NH)
NH-12/24-W	Horn, White (NH)
NS-241575W-FR	Horn/Strobe Wall Mount Flush Red 15/75cd
NS-241575W-FW	Horn/Strobe Wall Mount Flush White 15/75cd
NS-121575, NS-241575	Audible Strobe - 1575 cd, Wall
NS-24MCC	Audible Strobe - 15, 30, 75, 95 cd, Ceiling
NS-24MCCH	Audible Strobe - 115, 177 cd, Ceiling
NS-24MCCH-FR	Horn/Strobe, Ceiling, Round, 115/177cd, Red
NS-24MCW	Audible Strobe - 15, 30, 75, 110 cd, Wall
NS-24MCW-FR	Horn/Strobe, Multi-Candela, Red (NS)
NS-24MCW-FW	Horn/Strobe, Multi-Candela, White (NS)
PS-24-8MC	NAC Extender, 8 Amp, 4 Output, Red
RSS-241575, RSSP-241575	Strobe - 1575 cd, Wall
RSS-241575W-FR	Strobe Wall Mount Red 15/75 cd
RSS-241575W-FW	Strobe Wall Mount White 15/75cd
RSS-121575	Strobe - 1575 cd, Wall
RSS-35288C-FW	Strobe Ceiling Mount White 177cd
RSS-24185W-FR	Strobe Wall Mount Red 185cd
RSS-24177CR-FW	Strobe Ceiling Mount Round White 177cd
RSS-24177W-FR	Strobe Wall Mount Red 177 cd
RSS-24150C-FW	Strobe Ceiling Mount White 150cd
RSS-24150CR-FW	Strobe Ceiling Mount Round White 150cd
RSS-24150W-FR	Strobe Wall Mount Red 150cd
RSS-24100CR-FR	Strobe Ceiling Mount Round Red 100cd
RSS-24100CR-FW	Strobe Ceiling Mount Round White 100cd
RSS-2475CR-FR	Strobe Ceiling Mount Round Red 75cd

Model Number Series	Description
RSS-2475CR-FW	Strobe Ceiling Mount Round White 75cd
RSS-2430CR-FR	Strobe Ceiling Mount Round Red 30cd
RSS-2430CR-FW	Strobe Ceiling Mount Round White 30cd
RSS-2415CR-FR	Strobe Ceiling Mount Round Red 15cd
RSS-2415CR-FW	Strobe Ceiling Mount Round White 15cd
RSS-24MCC-FR	Strobe Ceiling Multi-Candela, Red (RSS)
RSS-24MCC-FW	Strobe Ceiling Multi-Candela, White (RSS)
RSS-24MCC, RSS-24MCCR	Strobe - 15, 30, 75, 95 cd, Ceiling (Round or Square)
RSS-24MCCH-FR	Strobe Ceiling, 115/177cd, Red (RSS)
RSS-24MCCH-FW	Strobe Ceiling, 115/177cd, White (RSS)
RSS-24MCCH, RSS-24MCCHR	Strobe - 115, 177 cd, Ceiling (Round or Square)
RSS-24MCCHR-FR	Strobe Red Multi Ceiling Round 115/177 cd
RSS-24MCCHR-FW	Strobe White Multi Ceiling Round 115/177 cd
RSS-24MCCR-FR	Strobe Ceiling Multi-Candela, Round, Red (RSS)
RSS-24MCCR-FW	Strobe Ceiling Multi-Candela, Round, White (RSS)
RSS-24MCW-FR	Strobe Wall Multi-Candela Red (RSS)
RSS-24MCW-FW	Strobe Wall Multi-Candela White (RSS)
RSS-24MCW, RSSP-24MCW	Strobe - 15, 30, 75, 110 cd, Wall
RSS-24MCWH-FR	Strobe, Wall, 135/185cd, Red (RSS)
RSS-24MCWH-FW	Strobe, Wall, 135/185cd, White (RSS)
RSS-24MCWH, RSSP-24MCWH	Strobe - 135, 185 cd, Wall
RSSP-241575W-FR	Strobe Wall Mount Retrofit Plate Red 15/75cd
RSSP-24185W-FR	Strobe Wall Mount Retrofit Plate Red 185cd
RSSP-24177W-FR	Strobe Wall Mount Retrofit Plate Red 177cd
RSSP-24150W-FR	Strobe Wall Mount Retrofit Plate Red 150cd
RSSP-24MCW-FR	Strobe Retro Multi-Candela, Red
RSSP-24MCW-FW	Strobe Retro Multi-Candela, White
RSSP-24MCWH-FR	Strobe Wall Mount Red Multi cd 135/185
RSSWP-2475W-FR	Strobe Wall Weatherproof, 75cd, Red
S8, S8-24MCC, S8-24MCCH	Speaker or Speaker Strobe - 8-inch, Ceiling
SA-S90-24MCC	Speaker Strobe - Amplified, 15, 30, 75, 95 cd, Ceiling
SA-S70-24MCW	Speaker Strobe - amplified, 15,30,75,115 cd, Wall
STH-4R24MCCH110	Cluster Speaker with three strobes
STH MCCH	Cluster Speakers - with 115/177 cd strobe
STH w/opt strobe	Cluster Speakers - with optional DC-MAX strobe
STR	Exceder Multi-Candela Strobe Wall Mount Red

Model Number Series	Description
STRC	Exceder Multi-Candela Strobe Ceiling Mount Red
STW	Exceder Multi-Candela Strobe Wall Mount White
STWC	Exceder Multi-Candela Strobe Ceiling Mount White
STx	Strobe - 15, 15/75, 30, 75, 95, 110, 135, 185 cd, Wall
STxC	Strobe - 15, 30, 60, 75, 95, 115, 150, 177 cd, Ceiling

Wheelock model numbers preceded by 'H' are Hochiki multiple-listed versions.

Riser conductors shall be installed in accordance with the survivability from attack by fire requirements in National Fire Alarm Code, NFPA 72, Sections 6.8.6.3, and 6.9.4. Riser conductors shall employ either a 2 hour rated cable system, or meet requirements approved by the AHJ, or installation of the Supervised Output Module using NFPA Style 7 configuration.

Maximum Line Impedance

Refer to Calculations to determine the maximum line impedance for your NAC application.

Compatible Devices for Auxiliary 24V

Model	Description
S787	L@titude Network Vision Annunciator
S560	16 Channel I/O Interface Module

Power connections of the remote display and annunciators must be terminated at the 24V terminals of the 24V OUT or AUX 24V on the FireNET L@titude Fire Alarm Control Panel.

APPENDIX C: CALCULATIONS

Current loading of the FireNET L@titude Fire Alarm Control Panel is limited to the capacity of the power supplies. Installers must determine the loading placed on these power supplies by adding the sum of device loads to the no load alarm current of the FireNET L@titude Fire Alarm Control Panel. The result obtained from this calculation must be below the operating current of the power supply.

The 5.25 Amp Power Supply operates the fire control panel and external loads with 5.25 Amps and reserves 1.25 Amps for charging the standby batteries.

The 10.25 Amp Power Supply operates the fire control panel and external loads with 10.25 Amps and reserves 2.25 Amps for charging the standby batteries.

Current limits are provided in Specifications for outputs of the FireNET L@titude Fire Alarm Control Panel. Total device currents must be below limits provided for all outputs of the fire control panel.

The calculation of total current loading must include the sum of device loads on the circuit outputs of the FireNET L@titude Fire Alarm Control Panel. Circuits to be included in this calculation for total current loading are:

- SLC Loops
- NAC Outputs
- 24V OUT
- AUX 24V
- Peripheral Interface Modules
- Network Module
- Panel Standby and Alarm Currents

The current limits provided in Specifications are maximums for individual outputs of the fire control panel. These output-levels are not intended to be summed together to determine the total current available from the FireNET L@titude Fire Alarm Control Panel. Refer to these levels only when determining the limit of device-loading on each output circuit.

SLC Loop Cabling

The FireNET L@titude Fire Alarm Control Panel requires that SLC Loops include wire gauge and lengths specified in tables of this section.

The maximum allowable voltage drop of 6.4 V is necessary on the SLC loop to maintain the minimum device operating voltage of 17 V. The worst case voltage drop occurs when the load is located at the farthest point from the terminals of the fire control panel.

Example Voltage Drop Condition

The following example demonstrates the impact of cable size and length on output circuits. A twin-wire of 16 AWG cabling is connected to SLC loop 1. The length of the 16 AWG cable is 1000 ft (305 m) and the device-load on the loop is 400 mA. The device-load of 400 mA is determined from manufacturer data sheets. The following figure illustrates the example SLC voltage drop condition of 16 AWG cable:

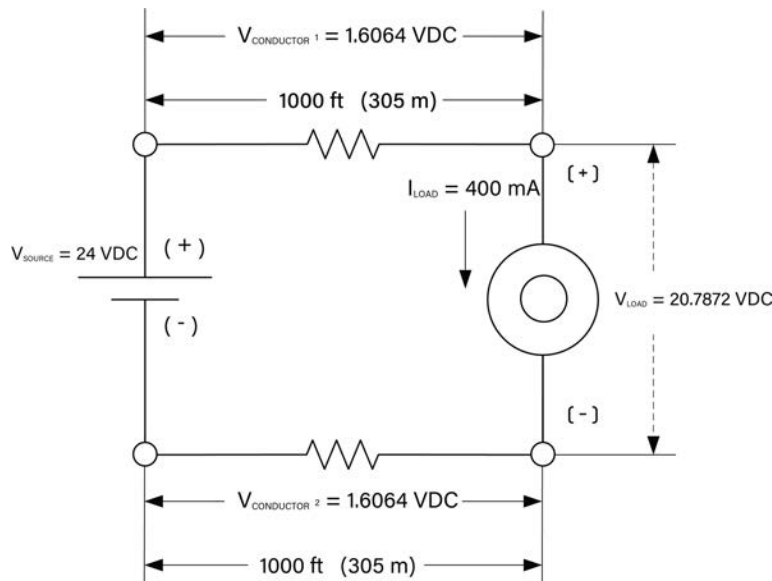

A voltage-drop of 1.6064V DC is determined from the table of 16 AWG cable for a single wire length of 1000 ft (305 m) and a load of 400 mA. The resistance of one wire of the 16 AWG cable is 4.016 Ω at 1000 ft.

Voltage-drop of the twin Conductor Cable

$$(V_{\text{conductor } 1} + V_{\text{conductor } 2}) = (1.6064\text{V DC} + 1.6064\text{V DC}) = 3.2128\text{V DC}$$

Voltage at the load

$$V_{load} = V_{source} - (V_{conductor 1} + V_{conductor 2}) = 24V DC - (1.6064V DC + 1.6064V DC) = 20.7872V DC$$

A voltage of 20.7872 VDC is available to operate the device at this circuit location.

Shading of the SLC tables identify cable length and load combinations that are not permitted for SLC loop devices. Light shading represents cable lengths that are not permitted when SLC circuits contain five or more isolators. Dark shading represents cable lengths that are not permitted without the connection of isolators in the SLC circuit.

Twin cables are connected to SLC loop terminals of the FireNET L@titude Fire Alarm Control Panel. Data provided in SLC tables of this section represent resistance and voltage from a single cable-conductor. Resistance and voltage levels obtained from these tables must include the secondary conductor of the twin cable during the evaluation process. SLC tables are provided for the following recommended wire gauges:

- 14 AWG 2.525 Ohms / 1000 ft
- 16 AWG 4.016 Ohms / 1000 ft
- 18 AWG 6.385 Ohms / 1000 ft

14 AWG Cable

Length in feet	Resistance Ω	Voltage Drop per Conductor				
		@ 0.1 A	@ 0.2 A	@ 0.3 A	@ 0.4 A	@ 0.5 A
100	0.2525	0.02525	0.0505	0.07575	0.101	0.12625
200	0.505	0.0505	0.101	0.1515	0.202	0.2525
300	0.7575	0.07575	0.1515	0.22725	0.303	0.37875
400	1.01	0.101	0.202	0.303	0.404	0.505
500	1.2625	0.12625	0.2525	0.37875	0.505	0.63125
600	1.515	0.1515	0.303	0.4545	0.606	0.7575
700	1.7675	0.17675	0.3535	0.53025	0.707	0.88375
800	2.02	0.202	0.404	0.606	0.808	1.01
900	2.2725	0.22725	0.4545	0.68175	0.909	1.13625
1000	2.525	0.2525	0.505	0.7575	1.01	1.2625
1100	2.7775	0.27775	0.5555	0.83325	1.111	1.38875
1200	3.03	0.303	0.606	0.909	1.212	1.515
1300	3.2825	0.32825	0.6565	0.98475	1.313	1.64125
1400	3.535	0.3535	0.707	1.0605	1.414	1.7675

Length in feet	Resistance Ω	Voltage Drop per Conductor				
		@ 0.1 A	@ 0.2 A	@ 0.3 A	@ 0.4 A	@ 0.5 A
1500	3.7875	0.37875	0.7575	1.13625	1.515	1.89375
1600	4.04	0.404	0.808	1.212	1.616	2.02
1700	4.2925	0.42925	0.8585	1.28775	1.717	2.14625
1800	4.545	0.4545	0.909	1.3635	1.818	2.2725
1900	4.7975	0.47975	0.9595	1.43925	1.919	2.39875
2000	5.05	0.505	1.01	1.515	2.02	2.525
2100	5.3025	0.53025	1.0605	1.59075	2.121	2.65125
2200	5.555	0.5555	1.111	1.6665	2.222	2.7775
2300	5.8075	0.58075	1.1615	1.74225	2.323	2.90375
2400	6.06	0.606	1.212	1.818	2.424	3.03
2500	6.3125	0.63125	1.2625	1.89375	2.525	3.15625
2600	6.565	0.6565	1.313	1.9695	2.626	3.2825
2700	6.8175	0.68175	1.3635	2.04525	2.727	3.40875
2800	7.07	0.707	1.414	2.121	2.828	3.535
2900	7.3225	0.73225	1.4645	2.19675	2.929	3.66125
3000	7.575	0.7575	1.515	2.2725	3.03	3.7875
3100	7.8275	0.78275	1.5655	2.34825	3.131	3.91375
3200	8.08	0.808	1.616	2.424	3.232	4.04
3300	8.3325	0.83325	1.6665	2.49975	3.333	4.16625
3400	8.585	0.8585	1.717	2.5755	3.434	4.2925
3500	8.8375	0.88375	1.7675	2.65125	3.535	4.41875
3600	9.09	0.909	1.818	2.727	3.636	4.545
3700	9.3425	0.93425	1.8685	2.80275	3.737	4.67125
3800	9.595	0.9595	1.919	2.8785	3.838	4.7975
3900	9.8475	0.98475	1.9695	2.95425	3.939	4.92375
4000	10.1	1.01	2.02	3.03	4.04	5.05
4100	10.3525	1.03525	2.0705	3.10575	4.141	5.17625
4200	10.605	1.0605	2.121	3.1815	4.242	5.3025
4300	10.8575	1.08575	2.1715	3.25725	4.343	5.42875
4400	11.11	1.111	2.222	3.333	4.444	5.555
4500	11.3625	1.13625	2.2725	3.40875	4.545	5.68125
4600	11.615	1.1615	2.323	3.4845	4.646	5.8075
4700	11.8675	1.18675	2.3735	3.56025	4.747	5.93375

Length in feet	Resistance Ω	Voltage Drop per Conductor				
		@ 0.1 A	@ 0.2 A	@ 0.3 A	@ 0.4 A	@ 0.5 A
4800	12.12	1.212	2.424	3.636	4.848	6.06
4900	12.3725	1.23725	2.4745	3.71175	4.949	6.18625
5000	12.625	1.2625	2.525	3.7875	5.05	6.3125
5100	12.8775	1.28775	2.5755	3.86325	5.151	6.43875
5200	13.13	1.313	2.626	3.939	42	6.565
5300	13.3825	1.33825	2.6765	4.01475	5.353	6.69125
5400	13.635	1.3635	2.727	4.0905	5.454	6.8175
5500	13.8875	1.38875	2.7775	4.16625	5.555	6.94375
5600	14.14	1.414	2.828	4.242	5.656	7.07
5700	14.3925	1.43925	2.8785	4.31775	5.757	7.19625
5800	14.645	1.4645	2.929	4.3935	5.858	7.3225
5900	14.8975	1.48975	2.9795	4.46925	5.959	7.44875
6000	15.15	1.515	3.03	4.545	6.06	7.575
6100	15.4025	1.54025	3.0805	4.62075	6.161	7.70125
6200	15.655	1.5655	3.131	4.6965	6.262	7.8275
6300	15.9075	1.59075	3.1815	4.77225	6.363	7.95375
6400	16.16	1.616	3.232	4.848	6.464	8.08
6500	16.4125	1.64125	3.2825	4.92375	6.565	8.20625
6600	16.665	1.6665	3.333	4.9995	6.666	8.3325

16 AWG Cable

Length in feet	Resistance Ω	Voltage Drop per Conductor				
		@ 0.1 A	@ 0.2 A	@ 0.3 A	@ 0.4 A	@ 0.5 A
100	0.4016	0.04016	0.08032	0.12048	0.16064	0.2008
200	0.8032	0.08032	0.16064	0.24096	0.32128	0.4016
300	1.2048	0.12048	0.24096	0.36144	0.48192	0.6024
400	1.6064	0.16064	0.32128	0.48192	0.64256	0.8032
500	2.008	0.2008	0.4016	0.6024	0.8032	1.004
600	2.4096	0.24096	0.48192	0.72288	0.96384	1.2048
700	2.8112	0.28112	0.56224	0.84336	1.12448	1.4056
800	3.2128	0.32128	0.64256	0.96384	1.28512	1.6064
900	3.6144	0.36144	0.72288	1.08432	1.44576	1.8072

Length in feet	Resistance Ω	Voltage Drop per Conductor				
		@ 0.1 A	@ 0.2 A	@ 0.3 A	@ 0.4 A	@ 0.5 A
1000	4.016	0.4016	0.8032	1.2048	1.6064	2.008
1100	4.4176	0.44176	0.88352	1.32528	1.76704	2.2088
1200	4.8192	0.48192	0.96384	1.44576	1.92768	2.4096
1300	5.2208	0.52208	1.04416	1.56624	2.08832	2.6104
1400	5.6224	0.56224	1.12448	1.68672	2.24896	2.8112
1500	6.024	0.6024	1.2048	1.8072	2.4096	3.012
1600	6.4256	0.64256	1.28512	1.92768	2.57024	3.2128
1700	6.8272	0.68272	1.36544	2.04816	2.73088	3.4136
1800	7.2288	0.72288	1.44576	2.16864	2.89152	3.6144
1900	7.6304	0.76304	1.52608	2.28912	3.05216	3.8152
2000	8.032	0.8032	1.6064	2.4096	3.2128	4.016
2100	8.4336	0.84336	1.68672	2.53008	3.37344	4.2168
2200	8.8352	0.88352	1.76704	2.65056	3.53408	4.4176
2300	9.2368	0.92368	1.84736	2.77104	3.69472	4.6184
2400	9.6384	0.96384	1.92768	2.89152	3.85536	4.8192
2500	10.04	1.004	2.008	3.012	4.016	5.02
2600	10.4416	1.04416	2.08832	3.13248	4.17664	5.2208
2700	10.8432	1.08432	2.16864	3.25296	4.33728	5.4216
2800	11.2448	1.12448	2.24896	3.37344	4.49792	5.6224
2900	11.6464	1.16464	2.32928	3.49392	4.65856	5.8232
3000	12.048	1.2048	2.4096	3.6144	4.8192	6.024
3100	12.4496	1.24496	2.48992	3.73488	4.97984	6.2248
3200	12.8512	1.28512	2.57024	3.85536	5.14048	6.4256
3300	13.2528	1.32528	2.65056	3.97584	5.30112	6.6264
3400	13.6544	1.36544	2.73088	4.09632	5.46176	6.8272
3500	14.056	1.4056	2.8112	4.2168	5.6224	7.028
3600	14.4576	1.44576	2.89152	4.33728	5.78304	7.2288
3700	14.8592	1.48592	2.97184	4.45776	5.94368	7.4296
3800	15.2608	1.52608	3.05216	4.57824	6.10432	7.6304
3900	15.6624	1.56624	3.13248	4.69872	6.26496	7.8312
4000	16.064	1.6064	3.2128	4.8192	6.4256	8.032
4100	16.4656	1.64656	3.29312	4.93968	6.58624	8.2328
4200	16.8672	1.68672	3.37344	5.06016	6.74688	8.4336

Length in feet	Resistance Ω	Voltage Drop per Conductor				
		@ 0.1 A	@ 0.2 A	@ 0.3 A	@ 0.4 A	@ 0.5 A
4300	17.2688	1.72688	3.45376	5.18064	6.90752	8.6344
4400	17.6704	1.76704	3.53408	5.30112	7.06816	8.8352
4500	18.072	1.8072	3.6144	5.4216	7.2288	9.036
4600	18.4736	1.84736	3.69472	5.54208	7.38944	9.2368
4700	18.8752	1.88752	3.77504	5.66256	7.55008	9.4376
4800	19.2768	1.92768	3.85536	5.78304	7.71072	9.6384
4900	19.6784	1.96784	3.93568	5.90352	7.87136	9.8392
5000	20.08	2.008	4.016	6.024	8.032	10.04
5100	20.4816	2.04816	4.09632	6.14448	8.19264	10.2408
5200	20.8832	2.08832	4.17664	6.26496	8.35328	10.4416
5300	21.2848	2.12848	4.25696	6.38544	8.51392	10.6424
5400	21.6864	2.16864	4.33728	6.50592	8.67456	10.8432
5500	22.088	2.2088	4.4176	6.6264	8.8352	11.044
5600	22.4896	2.24896	4.49792	6.74688	8.99584	11.2448
5700	22.8912	2.28912	4.57824	6.86736	9.15648	11.4456
5800	23.2928	2.32928	4.65856	6.98784	9.31712	11.6464
5900	23.6944	2.36944	4.73888	7.10832	9.47776	11.8472
6000	24.096	2.4096	4.8192	7.2288	9.6384	12.048
6100	24.4976	2.44976	4.89952	7.34928	9.79904	12.2488
6200	24.8992	2.48992	4.97984	7.46976	9.95968	12.4496
6300	25.3008	2.53008	5.06016	7.59024	10.12032	12.6504
6400	25.7024	2.57024	5.14048	7.71072	10.28096	12.8512
6500	26.104	2.6104	5.2208	7.8312	10.4416	13.052
6600	26.5056	2.65056	5.30112	7.95168	10.60224	13.2528

18 AWG Cable

Length in feet	Resistance Ω	Voltage Drop per Conductor				
		@ 0.1 A	@ 0.2 A	@ 0.3 A	@ 0.4 A	@ 0.5 A
100	0.6385	0.06385	0.1277	0.19155	0.2554	0.31925
200	1.277	0.1277	0.2554	0.3831	0.5108	0.6385
300	1.9155	0.19155	0.3831	0.57465	0.7662	0.95775
400	2.554	0.2554	0.5108	0.7662	1.0216	1.277
500	3.1925	0.31925	0.6385	0.95775	1.277	1.59625

Length in feet	Resistance Ω	Voltage Drop per Conductor				
		@ 0.1 A	@ 0.2 A	@ 0.3 A	@ 0.4 A	@ 0.5 A
600	3.831	0.3831	0.7662	1.1493	1.5324	1.9155
700	4.4695	0.44695	0.8939	1.34085	1.7878	2.23475
800	5.108	0.5108	1.0216	1.5324	2.0432	2.554
900	5.7465	0.57465	1.1493	1.72395	2.2986	2.87325
1000	6.385	0.6385	1.277	1.9155	2.554	3.1925
1100	7.0235	0.70235	1.4047	2.10705	2.8094	3.51175
1200	7.662	0.7662	1.5324	2.2986	3.0648	3.831
1300	8.3005	0.83005	1.6601	2.49015	3.3202	4.15025
1400	8.939	0.8939	1.7878	2.6817	3.5756	4.4695
1500	9.5775	0.95775	1.9155	2.87325	3.831	4.78875
1600	10.216	1.0216	2.0432	3.0648	4.0864	5.108
1700	10.8545	1.08545	2.1709	3.25635	4.3418	5.42725
1800	11.493	1.1493	2.2986	3.4479	4.5972	5.7465
1900	12.1315	1.21315	2.4263	3.63945	4.8526	6.06575
2000	12.77	1.277	2.554	3.831	5.108	6.385
2100	13.4085	1.34085	2.6817	4.02255	5.3634	6.70425
2200	14.047	1.4047	2.8094	4.2141	5.6188	7.0235
2300	14.6855	1.46855	2.9371	4.40565	5.8742	7.34275
2400	15.324	1.5324	3.0648	4.5972	6.1296	7.662
2500	15.9625	1.59625	3.1925	4.78875	6.385	7.98125
2600	16.601	1.6601	3.3202	4.9803	6.6404	8.3005
2700	17.2395	1.72395	3.4479	5.17185	6.8958	8.61975
2800	17.878	1.7878	3.5756	5.3634	7.1512	8.939
2900	18.5165	1.85165	3.7033	5.55495	7.4066	9.25825
3000	19.155	1.9155	3.831	5.7465	7.662	9.5775
3100	19.7935	1.97935	3.9587	5.93805	7.9174	9.89675
3200	20.432	2.0432	4.0864	6.1296	8.1728	10.216
3300	21.0705	2.10705	4.2141	6.32115	8.4282	10.53525
3400	21.709	2.1709	4.3418	6.5127	8.6836	10.8545
3500	22.3475	2.23475	4.4695	6.70425	8.939	11.17375
3600	22.986	2.2986	4.5972	6.8958	9.1944	11.493
3700	23.6245	2.36245	4.7249	7.08735	9.4498	11.81225
3800	24.263	2.4263	4.8526	7.2789	9.7052	12.1315

Length in feet	Resistance Ω	Voltage Drop per Conductor				
		@ 0.1 A	@ 0.2 A	@ 0.3 A	@ 0.4 A	@ 0.5 A
3900	24.9015	2.49015	4.9803	7.47045	9.9606	12.45075
4000	25.54	2.554	5.108	7.662	10.216	12.77
4100	26.1785	2.61785	5.2357	7.85355	10.4714	13.08925
4200	26.817	2.6817	5.3634	8.0451	10.7268	13.4085
4300	27.4555	2.74555	5.4911	8.23665	10.9822	13.72775
4400	28.094	2.8094	5.6188	8.4282	11.2376	14.047
4500	28.7325	2.87325	5.7465	8.61975	11.493	14.36625
4600	29.371	2.9371	5.8742	8.8113	11.7484	14.6855
4700	30.0095	3.00095	6.0019	9.00285	12.0038	15.00475
4800	30.648	3.0648	6.1296	9.1944	12.2592	15.324
4900	31.2865	3.12865	6.2573	9.38595	12.5146	15.64325
5000	31.925	3.1925	6.385	9.5775	12.77	15.9625
5100	32.5635	3.25635	6.5127	9.76905	13.0254	16.28175
5200	33.202	3.3202	6.6404	9.9606	13.2808	16.601
5300	33.8405	3.38405	6.7681	10.15215	13.5362	16.92025
5400	34.479	3.4479	6.8958	10.3437	13.7916	17.2395
5500	35.1175	3.51175	7.0235	10.53525	14.047	17.55875
5600	35.756	3.5756	7.1512	10.7268	14.3024	17.878
5700	36.3945	3.63945	7.2789	10.91835	14.5578	18.19725
5800	37.033	3.7033	7.4066	11.1099	14.8132	18.5165
5900	37.6715	3.76715	7.5343	11.30145	15.0686	18.83575
6000	38.31	3.831	7.662	11.493	15.324	19.155
6100	38.9485	3.89485	7.7897	11.68455	15.5794	19.47425
6200	39.587	3.9587	7.9174	11.8761	15.8348	19.7935
6300	40.2255	4.02255	8.0451	12.06765	16.0902	20.11275
6400	40.864	4.0864	8.1728	12.2592	16.3456	20.432
6500	41.5025	4.15025	8.3005	12.45075	16.601	20.75125
6600	42.141	4.2141	8.4282	12.6423	16.8564	21.0705

NAC Cabling

The FireNET L@titude Fire Alarm Control Panel requires that NAC circuits include wire gauge and lengths specified in tables of this section. Shading of the tables identify cable length and load combinations that are not permitted for NAC devices.

Twin cables are connected to NAC terminals of the FireNET L@titude Fire Alarm Control Panel. Data provided in the tables of this section represent resistance and voltage from a single cable-conductor. Resistance and voltage levels obtained from these tables must include the secondary conductor of the twin cable during the evaluation process.

Cable length values in the tables represent worst case conditions with the total load at the farthest point from terminals of the fire control panel. Voltage drops are represented with a depleted battery of 20.4V. Minimum output voltage is 20V. maximum allowable voltage drop is 4V to ensure a minimum of 16V at the device.

Tables are provided for the following recommended wire gauges:

12 AWG	1.588 Ohms / 1000 ft
14 AWG	2.525 Ohms / 1000 ft
16 AWG	4.016 Ohms / 1000 ft

12 AWG Cable

Length (in feet)	Resistance Ω	Voltage Drop per Conductor									
		@ 0.25 A	@ 0.5 A	@ 0.75 A	@ 1.0 A	@ 1.25 A	@ 1.50 A	@ 1.75 A	@ 2.00 A	@ 2.25 A	@ 2.50 A
25	0.0397	0.00992	0.01985	0.02977	0.0397	0.049625	0.05955	0.069475	0.0794	0.089325	0.09925
50	0.07964	0.01991	0.03982	0.05973	0.07964	0.09955	0.11946	0.13937	0.15928	0.17919	0.1991
100	0.15944	0.03986	0.07972	0.11958	0.15944	0.1993	0.23916	0.27902	0.31888	0.35874	0.3986
150	0.23924	0.05981	0.11962	0.17943	0.23924	0.29905	0.35886	0.41867	0.47848	0.53829	0.5981
200	0.31904	0.07976	0.15952	0.23928	0.31904	0.3988	0.47856	0.55832	0.63808	0.71784	0.7976
250	0.39884	0.09971	0.19942	0.29913	0.39884	0.49855	0.59826	0.69797	0.79768	0.89739	0.9971
300	0.47864	0.11966	0.23932	0.35898	0.47864	0.5983	0.71796	0.83762	0.95728	1.07694	1.1966
350	0.55844	0.13961	0.27922	0.41883	0.55844	0.69805	0.83766	0.97727	1.11688	1.25649	1.3961
400	0.63824	0.15956	0.31912	0.47868	0.63824	0.7978	0.95736	1.11692	1.27648	1.43604	1.5956
450	0.71804	0.17951	0.35902	0.53853	0.71804	0.89755	1.07706	1.25657	1.43608	1.61559	1.7951
500	0.79784	0.19946	0.39892	0.59838	0.79784	0.9973	1.19676	1.39622	1.59568	1.79514	1.9946

Length (in feet)	Resistance Ω	Voltage Drop per Conductor									
		@ 0.25 A	@ 0.5 A	@ 0.75 A	@ 1.0 A	@ 1.25 A	@ 1.50 A	@ 1.75 A	@ 2.00 A	@ 2.25 A	@ 2.50 A
550	0.87764	0.21941	0.43882	0.65823	0.87764	1.09705	1.31646	1.53587	1.75528	1.97469	2.1941
600	0.95744	0.23936	0.47872	0.71808	0.95744	1.1968	1.43616	1.67552	1.91488	2.15424	2.3936
650	1.03724	0.25931	0.51862	0.77793	1.03724	1.29655	1.55586	1.81517	2.07448	2.33379	2.5931
700	1.11704	0.27926	0.55852	0.83778	1.11704	1.3963	1.67556	1.95482	2.23408	2.51334	2.7926
750	1.19684	0.29921	0.59842	0.89763	1.19684	1.49605	1.79526	2.09447	2.39368	2.69289	2.9921
800	1.27664	0.31916	0.63832	0.95748	1.27664	1.5958	1.91496	2.23412	2.55328	2.87244	3.1916
850	1.35644	0.33911	0.67822	1.01733	1.35644	1.69555	2.03466	2.37377	2.71288	3.05199	3.3911
900	1.43624	0.35906	0.71812	1.07718	1.43624	1.7953	2.15436	2.51342	2.87248	3.23154	3.5906
950	1.51604	0.37901	0.75802	1.13703	1.51604	1.89505	2.27406	2.65307	3.03208	3.41109	3.7901
1000	1.59584	0.39896	0.79792	1.19688	1.59584	1.9948	2.39376	2.79272	3.19168	3.59064	3.9896
1050	1.67564	0.41891	0.83782	1.25673	1.67564	2.09455	2.51346	2.93237	3.35128	3.77019	4.1891
1100	1.75544	0.43886	0.87772	1.31658	1.75544	2.1943	2.63316	3.07202	3.51088	3.94974	4.3886
1150	1.83524	0.45881	0.91762	1.37643	1.83524	2.29405	2.75286	3.21167	3.67048	4.12929	4.5881
1200	1.91504	0.47876	0.95752	1.43628	1.91504	2.3938	2.87256	3.35132	3.83008	4.30884	4.7876
1250	1.99484	0.49871	0.99742	1.49613	1.99484	2.49355	2.99226	3.49097	3.98968	4.48839	4.9871
1300	2.07464	0.51866	1.03732	1.55598	2.07464	2.5933	3.11196	3.63062	4.14928	4.66794	5.1866
1350	2.15444	0.53861	1.07722	1.61583	2.15444	2.69305	3.23166	3.77027	4.30888	4.84749	5.3861
1400	2.23424	0.55856	1.11712	1.67568	2.23424	2.7928	3.35136	3.90992	4.46848	5.02704	5.5856
1450	2.31404	0.57851	1.15702	1.73553	2.31404	2.89255	3.47106	4.04957	4.62808	5.20659	5.7851
1500	2.39384	0.59846	1.19692	1.79538	2.39384	2.9923	3.59076	4.18922	4.78768	5.38614	5.9846
1550	2.47364	0.61841	1.23682	1.85523	2.47364	3.09205	3.71046	4.32887	4.94728	5.56569	6.1841
1600	2.55344	0.63836	1.27672	1.91508	2.55344	3.1918	3.83016	4.46852	5.10688	5.74524	6.3836
1650	2.63324	0.65831	1.31662	1.97493	2.63324	3.29155	3.94986	4.60817	5.26648	5.92479	6.5831

14 AWG Cable

Length (in feet)	Resistance Ω	Voltage Drop per Conductor									
		@ 0.25 A	@ 0.5 A	@ 0.75 A	@ 1.0 A	@ 1.25 A	@ 1.50 A	@ 1.75 A	@ 2.00 A	@ 2.25 A	@ 2.50 A
25	0.063125	0.01578125	0.0315625	0.04734375	0.063125	0.07890625	0.0946875	0.11046875	0.12625	0.14203125	0.1578125
50	0.12625	0.0315625	0.063125	0.0946875	0.12625	0.1578125	0.189375	0.2209375	0.2525	0.2840625	0.315665
100	0.2525	0.063125	0.12625	0.189375	0.2525	0.315625	0.37875	0.441875	0.505	0.568125	0.63134
150	0.37875	0.0946875	0.189375	0.2840625	0.37875	0.4734375	0.568125	0.6628125	0.7575	0.8521875	0.947015

Length (in feet)	Resistance Ω	Voltage Drop per Conductor									
		@ 0.25 A	@ 0.5 A	@ 0.75 A	@ 1.0 A	@ 1.25 A	@ 1.50 A	@ 1.75 A	@ 2.00 A	@ 2.25 A	@ 2.50 A
200	0.505	0.12625	0.2525	0.37875	0.505	0.63125	0.7575	0.88375	1.01	1.13625	1.26269
250	0.63125	0.1578125	0.315625	0.4734375	0.63125	0.7890625	0.946875	1.1046875	1.2625	1.4203125	1.578365
300	0.7575	0.189375	0.37875	0.568125	0.7575	0.946875	1.13625	1.325625	1.515	1.704375	1.89404
350	0.88375	0.2209375	0.441875	0.6628125	0.88375	1.1046875	1.325625	1.5465625	1.7675	1.9884375	2.209715
400	1.01	0.2525	0.505	0.7575	1.01	1.2625	1.515	1.7675	2.02	2.2725	2.52539
450	1.13625	0.2840625	0.568125	0.8521875	1.13625	1.4203125	1.704375	1.9884375	2.2725	2.5565625	2.841065
500	1.2625	0.315625	0.63125	0.946875	1.2625	1.578125	1.89375	2.209375	2.525	2.840625	3.15674
550	1.38875	0.3471875	0.694375	1.0415625	1.38875	1.7359375	2.083125	2.4303125	2.7775	3.1246875	3.472415
600	1.515	0.37875	0.7575	1.13625	1.515	1.89375	2.2725	2.65125	3.03	3.40875	3.78809
650	1.64125	0.4103125	0.820625	1.2309375	1.64125	2.0515625	2.461875	2.8721875	3.2825	3.6928125	4.103765
700	1.7675	0.441875	0.88375	1.325625	1.7675	2.209375	2.65125	3.093125	3.535	3.976875	4.41944
750	1.89375	0.4734375	0.946875	1.4203125	1.89375	2.3671875	2.840625	3.3140625	3.7875	4.2609375	4.735115
800	2.02	0.505	1.01	1.515	2.02	2.525	3.03	3.535	4.04	4.545	5.05079
850	2.14625	0.5365625	1.073125	1.6096875	2.14625	2.6828125	3.219375	3.7559375	4.2925	4.8290625	5.366465
900	2.2725	0.568125	1.13625	1.704375	2.2725	2.840625	3.40875	3.976875	4.545	5.113125	5.68214
950	2.39875	0.5996875	1.199375	1.7990625	2.39875	2.9984375	3.598125	4.1978125	4.7975	5.3971875	5.997815
1000	2.525	0.63125	1.2625	1.89375	2.525	3.15625	3.7875	4.41875	5.05	5.68125	6.31349
1050	2.65125	0.6628125	1.325625	1.9884375	2.65125	3.3140625	3.976875	4.6396875	5.3025	5.9653125	6.629165
1100	2.7775	0.694375	1.38875	2.083125	2.7775	3.471875	4.16625	4.860625	5.555	6.249375	6.94484
1150	2.90375	0.7259375	1.451875	2.1778125	2.90375	3.6296875	4.355625	5.0815625	5.8075	6.5334375	7.260515
1200	3.03	0.7575	1.515	2.2725	3.03	3.7875	4.545	5.3025	6.06	6.8175	7.57619
1250	3.15625	0.7890625	1.578125	2.3671875	3.15625	3.9453125	4.734375	5.5234375	6.3125	7.1015625	7.891865
1300	3.2825	0.820625	1.64125	2.461875	3.2825	4.103125	4.92375	5.744375	6.565	7.385625	8.20754
1350	3.40875	0.8521875	1.704375	2.5565625	3.40875	4.2609375	5.113125	5.9653125	6.8175	7.6696875	8.523215
1400	3.535	0.88375	1.7675	2.65125	3.535	4.41875	5.3025	6.18625	7.07	7.95375	8.83889
1450	3.66125	0.9153125	1.830625	2.7459375	3.66125	4.5765625	5.491875	6.4071875	7.3225	8.2378125	9.154565
1500	3.7875	0.946875	1.89375	2.840625	3.7875	4.734375	5.68125	6.628125	7.575	8.521875	9.47024
1550	3.91375	0.9784375	1.956875	2.9353125	3.91375	4.8921875	5.870625	6.8490625	7.8275	8.8059375	9.785915
1600	4.04	1.01	2.02	3.03	4.04	5.05	6.06	7.07	8.08	9.09	10.10159
1650	4.16625	1.0415625	2.083125	3.1246875	4.16625	5.2078125	6.249375	7.2909375	8.3325	9.3740625	10.417265

16 AWG Cable

Length (in feet)	Resistance Ω	Voltage Drop per Conductor									
		@ 0.25 A	@ 0.5 A	@ 0.75 A	@ 1.0 A	@ 1.25 A	@ 1.50 A	@ 1.75 A	@ 2.00 A	@ 2.25 A	@ 2.50 A
25	0.1004	0.0251	0.0502	0.0753	0.1004	0.1255	0.1506	0.1757	0.2008	0.2259	0.251
50	0.2008	0.0502	0.1004	0.1506	0.2008	0.251	0.3012	0.3514	0.4016	0.4518	0.502
100	0.4016	0.1004	0.2008	0.3012	0.4016	0.502	0.6024	0.7028	0.8032	0.9036	1.004
150	0.6024	0.1506	0.3012	0.4518	0.6024	0.753	0.9036	1.0542	1.2048	1.3554	1.506
200	0.8032	0.2008	0.4016	0.6024	0.8032	1.004	1.2048	1.4056	1.6064	1.8072	2.008
250	1.004	0.251	0.502	0.753	1.004	1.255	1.506	1.757	2.008	2.259	2.51
300	1.2048	0.3012	0.6024	0.9036	1.2048	1.506	1.8072	2.1084	2.4096	2.7108	3.012
350	1.4056	0.3514	0.7028	1.0542	1.4056	1.757	2.1084	2.4598	2.8112	3.1626	3.514
400	1.6064	0.4016	0.8032	1.2048	1.6064	2.008	2.4096	2.8112	3.2128	3.6144	4.016
450	1.8072	0.4518	0.9036	1.3554	1.8072	2.259	2.7108	3.1626	3.6144	4.0662	4.518
500	2.008	0.502	1.004	1.506	2.008	2.51	3.012	3.514	4.016	4.518	5.02
550	2.2088	0.5522	1.1044	1.6566	2.2088	2.761	3.3132	3.8654	4.4176	4.9698	5.522
600	2.4096	0.6024	1.2048	1.8072	2.4096	3.012	3.6144	4.2168	4.8192	5.4216	6.024
650	2.6104	0.6526	1.3052	1.9578	2.6104	3.263	3.9156	4.5682	5.2208	5.8734	6.526
700	2.8112	0.7028	1.4056	2.1084	2.8112	3.514	4.2168	4.9196	5.6224	6.3252	7.028
750	3.012	0.753	1.506	2.259	3.012	3.765	4.518	5.271	6.024	6.777	7.53
800	3.2128	0.8032	1.6064	2.4096	3.2128	4.016	4.8192	5.6224	6.4256	7.2288	8.032
850	3.4136	0.8534	1.7068	2.5602	3.4136	4.267	5.1204	5.9738	6.8272	7.6806	8.534
900	3.6144	0.9036	1.8072	2.7108	3.6144	4.518	5.4216	6.3252	7.2288	8.1324	9.036
950	3.8152	0.9538	1.9076	2.8614	3.8152	4.769	5.7228	6.6766	7.6304	8.5842	9.538
1000	4.016	1.004	2.008	3.012	4.016	5.02	6.024	7.028	8.032	9.036	10.04
1050	4.2168	1.0542	2.1084	3.1626	4.2168	5.271	6.3252	7.3794	8.4336	9.4878	10.542
1100	4.4176	1.1044	2.2088	3.3132	4.4176	5.522	6.6264	7.7308	8.8352	9.9396	11.044
1150	4.6184	1.1546	2.3092	3.4638	4.6184	5.773	6.9276	8.0822	9.2368	10.3914	11.546
1200	4.8192	1.2048	2.4096	3.6144	4.8192	6.024	7.2288	8.4336	9.6384	10.8432	12.048
1250	5.02	1.255	2.51	3.765	5.02	6.275	7.53	8.785	10.04	11.295	12.55
1300	5.2208	1.3052	2.6104	3.9156	5.2208	6.526	7.8312	9.1364	10.4416	11.7468	13.052
1350	5.4216	1.3554	2.7108	4.0662	5.4216	6.777	8.1324	9.4878	10.8432	12.1986	13.554
1400	5.6224	1.4056	2.8112	4.2168	5.6224	7.028	8.4336	9.8392	11.2448	12.6504	14.056
1450	5.8232	1.4558	2.9116	4.3674	5.8232	7.279	8.7348	10.1906	11.6464	13.1022	14.558
1500	6.024	1.506	3.012	4.518	6.024	7.53	9.036	10.542	12.048	13.554	15.06

Length (in feet)	Resistance Ω	Voltage Drop per Conductor									
		@ 0.25 A	@ 0.5 A	@ 0.75 A	@ 1.0 A	@ 1.25 A	@ 1.50 A	@ 1.75 A	@ 2.00 A	@ 2.25 A	@ 2.50 A
1550	6.2248	1.5562	3.1124	4.6686	6.2248	7.781	9.3372	10.8934	12.4496	14.0058	15.562
1600	6.4256	1.6064	3.2128	4.8192	6.4256	8.032	9.6384	11.2448	12.8512	14.4576	16.064
1650	6.6264	1.6566	3.3132	4.9698	6.6264	8.283	9.9396	11.5962	13.2528	14.9094	16.566

AUX 24V Cabling

The FireNET L@titude Fire Alarm Control Panel requires that AUX 24V circuits include wire gauge and lengths specified in tables of this section.

Twin cables are connected to AUX 24V terminals of the FireNET L@titude Fire Alarm Control Panel. Data provided in AUX 24V tables of this section represent resistance and voltage from a single cable-conductor. Resistance and voltage levels obtained from these tables must include the secondary conductor of the twin cable during the evaluation process.

Cable length values in the tables represent worst case conditions with the total load at the farthest point from terminals of the fire control panel.

AUX 24V tables are provided for the following recommended wire gauges:

12 AWG	1.588 Ohms / 1000 ft
14 AWG	2.525 Ohms / 1000 ft
16 AWG	4.016 Ohms / 1000 ft

12 AWG Cable

Length (in feet)	Resistance Ω	Voltage Drop per Conductor			
		@ 0.1 A	@ 0.2 A	@ 0.3 A	@ 0.4 A
100	0.15944	0.015944	0.031888	0.047832	0.063776
200	0.31904	0.031952	0.063808	0.095712	0.127616
300	0.47864	0.04796	0.095728	0.143592	0.191456
400	0.63824	0.063968	0.127648	0.191472	0.255296
500	0.79784	0.079976	0.159568	0.239352	0.319136
600	0.95744	0.095984	0.191488	0.287232	0.382976
700	1.11704	0.111992	0.223408	0.335112	0.446816
800	1.27664	0.128	0.255328	0.382992	0.510656
900	1.43624	0.144008	0.287248	0.430872	0.574496
1000	1.59584	0.160016	0.319168	0.478752	0.638336
1100	1.75544	0.176024	0.351088	0.526632	0.702176
1200	1.91504	0.192032	0.383008	0.574512	0.766016
1300	2.07464	0.20804	0.414928	0.622392	0.829856

Length (in feet)	Resistance Ω	Voltage Drop per Conductor			
		@ 0.1 A	@ 0.2 A	@ 0.3 A	@ 0.4 A
1400	2.23424	0.224048	0.446848	0.670272	0.893696
1500	2.39384	0.240056	0.478768	0.718152	0.957536
1600	2.55344	0.256064	0.510688	0.766032	1.021376
1700	2.71304	0.272072	0.542608	0.813912	1.085216
1800	2.87264	0.28808	0.574528	0.861792	1.149056
1900	3.03224	0.304088	0.606448	0.909672	1.212896
2000	3.19184	0.320096	0.638368	0.957552	1.276736
2100	3.35144	0.336104	0.670288	1.005432	1.340576
2200	3.51104	0.352112	0.702208	1.053312	1.404416
2300	3.67064	0.36812	0.734128	1.101192	1.468256
2400	3.83024	0.384128	0.766048	1.149072	1.532096
2500	3.98984	0.400136	0.797968	1.196952	1.595936
2600	4.14944	0.416144	0.829888	1.244832	1.659776
2700	4.30904	0.432152	0.861808	1.292712	1.723616
2800	4.46864	0.44816	0.893728	1.340592	1.787456
2900	4.62824	0.464168	0.925648	1.388472	1.851296
3000	4.78784	0.480176	0.957568	1.436352	1.915136
3100	4.94744	0.496184	0.989488	1.484232	1.978976
3200	5.10704	0.512192	1.021408	1.532112	2.042816
3300	5.26664	0.5282	1.053328	1.579992	2.106656
3400	5.42624	0.544208	1.085248	1.627872	2.170496
3500	5.58584	0.560216	1.117168	1.675752	2.234336
3600	5.74544	0.576224	1.149088	1.723632	2.298176
3700	5.90504	0.592232	1.181008	1.771512	2.362016
3800	6.06464	0.60824	1.212928	1.819392	2.425856
3900	6.22424	0.624248	1.244848	1.867272	2.489696
4000	6.38384	0.640256	1.276768	1.915152	2.553536
4100	6.54344	0.656264	1.308688	1.963032	2.617376
4200	6.70304	0.672272	1.340608	2.010912	2.681216
4300	6.86264	0.68828	1.372528	2.058792	2.745056
4400	7.02224	0.704288	1.404448	2.106672	2.808896
4500	7.18184	0.720296	1.436368	2.154552	2.872736
4600	7.34144	0.736304	1.468288	2.202432	2.936576

Length (in feet)	Resistance Ω	Voltage Drop per Conductor			
		@ 0.1 A	@ 0.2 A	@ 0.3 A	@ 0.4 A
4700	7.50104	0.752312	1.500208	2.250312	3.000416
4800	7.66064	0.76832	1.532128	2.298192	3.064256
4900	7.82024	0.784328	1.564048	2.346072	3.128096
5000	7.97984	0.800336	1.595968	2.393952	3.191936
5100	8.13944	0.816344	1.627888	2.441832	3.255776
5200	8.29904	0.832352	1.659808	2.489712	3.319616
5300	8.45864	0.84836	1.691728	2.537592	3.383456
5400	8.61824	0.864368	1.723648	2.585472	3.447296
5500	8.77784	0.880376	1.755568	2.633352	3.511136
5600	8.93744	0.896384	1.787488	2.681232	3.574976
5700	9.09704	0.912392	1.819408	2.729112	3.638816
5800	9.25664	0.9284	1.851328	2.776992	3.702656
5900	9.41624	0.944408	1.883248	2.824872	3.766496
6000	9.57584	0.960416	1.915168	2.872752	3.830336
6100	9.73544	0.976424	1.947088	2.920632	3.894176
6200	9.89504	0.992432	1.979008	2.968512	3.958016
6300	10.05464	1.00844	2.010928	3.016392	4.021856
6400	10.21424	1.024448	2.042848	3.064272	4.085696
6500	10.37384	1.040456	2.074768	3.112152	4.149536
6600	10.53344	1.056464	2.106688	3.160032	4.213376

14 AWG Cable

Length (in feet)	Resistance Ω	Voltage Drop per Conductor			
		@ 0.1 A	@ 0.2 A	@ 0.3 A	@ 0.4 A
100	0.2525	0.02525	0.0505	0.07575	0.101
200	0.505	0.0505	0.101	0.1515	0.202
300	0.7575	0.07575	0.1515	0.22725	0.303
400	1.01	0.101	0.202	0.303	0.404
500	1.2625	0.12625	0.2525	0.37875	0.505
600	1.515	0.1515	0.303	0.4545	0.606
700	1.7675	0.17675	0.3535	0.53025	0.707
800	2.02	0.202	0.404	0.606	0.808

Length (in feet)	Resistance Ω	Voltage Drop per Conductor			
		@ 0.1 A	@ 0.2 A	@ 0.3 A	@ 0.4 A
900	2.2725	0.22725	0.4545	0.68175	0.909
1000	2.525	0.2525	0.505	0.7575	1.01
1100	2.7775	0.27775	0.5555	0.83325	1.111
1200	3.03	0.303	0.606	0.909	1.212
1300	3.2825	0.32825	0.6565	0.98475	1.313
1400	3.535	0.3535	0.707	1.0605	1.414
1500	3.7875	0.37875	0.7575	1.13625	1.515
1600	4.04	0.404	0.808	1.212	1.616
1700	4.2925	0.42925	0.8585	1.28775	1.717
1800	4.545	0.4545	0.909	1.3635	1.818
1900	4.7975	0.47975	0.9595	1.43925	1.919
2000	5.05	0.505	1.01	1.515	2.02
2100	5.3025	0.53025	1.0605	1.59075	2.121
2200	5.555	0.5555	1.111	1.6665	2.222
2300	5.8075	0.58075	1.1615	1.74225	2.323
2400	6.06	0.606	1.212	1.818	2.424
2500	6.3125	0.63125	1.2625	1.89375	2.525
2600	6.565	0.6565	1.313	1.9695	2.626
2700	6.8175	0.68175	1.3635	2.04525	2.727
2800	7.07	0.707	1.414	2.121	2.828
2900	7.3225	0.73225	1.4645	2.19675	2.929
3000	7.575	0.7575	1.515	2.2725	3.03
3100	7.8275	0.78275	1.5655	2.34825	3.131
3200	8.08	0.808	1.616	2.424	3.232
3300	8.3325	0.83325	1.6665	2.49975	3.333
3400	8.585	0.8585	1.717	2.5755	3.434
3500	8.8375	0.88375	1.7675	2.65125	3.535
3600	9.09	0.909	1.818	2.727	3.636
3700	9.3425	0.93425	1.8685	2.80275	3.737
3800	9.595	0.9595	1.919	2.8785	3.838
3900	9.8475	0.98475	1.9695	2.95425	3.939
4000	10.1	1.01	2.02	3.03	4.04
4100	10.3525	1.03525	2.0705	3.10575	4.141

Length (in feet)	Resistance Ω	Voltage Drop per Conductor			
		@ 0.1 A	@ 0.2 A	@ 0.3 A	@ 0.4 A
4200	10.605	1.0605	2.121	3.1815	4.242
4300	10.8575	1.08575	2.1715	3.25725	4.343
4400	11.11	1.111	2.222	3.333	4.444
4500	11.3625	1.13625	2.2725	3.40875	4.545
4600	11.615	1.1615	2.323	3.4845	4.646
4700	11.8675	1.18675	2.3735	3.56025	4.747
4800	12.12	1.212	2.424	3.636	4.848
4900	12.3725	1.23725	2.4745	3.71175	4.949
5000	12.625	1.2625	2.525	3.7875	5.05
5100	12.8775	1.28775	2.5755	3.86325	5.151
5200	13.13	1.313	2.626	3.939	42
5300	13.3825	1.33825	2.6765	4.01475	5.353
5400	13.635	1.3635	2.727	4.0905	5.454
5500	13.8875	1.38875	2.7775	4.16625	5.555
5600	14.14	1.414	2.828	4.242	5.656
5700	14.3925	1.43925	2.8785	4.31775	5.757
5800	14.645	1.4645	2.929	4.3935	5.858
5900	14.8975	1.48975	2.9795	4.46925	5.959
6000	15.15	1.515	3.03	4.545	6.06
6100	15.4025	1.54025	3.0805	4.62075	6.161
6200	15.655	1.5655	3.131	4.6965	6.262
6300	15.9075	1.59075	3.1815	4.77225	6.363
6400	16.16	1.616	3.232	4.848	6.464
6500	16.4125	1.64125	3.2825	4.92375	6.565
6600	16.665	1.6665	3.333	4.9995	6.666

16 AWG Cable

Length (in feet)	Resistance Ω	Voltage Drop per Conductor			
		@ 0.1 A	@ 0.2 A	@ 0.3 A	@ 0.4 A
100	0.4016	0.04016	0.08032	0.12048	0.16064
200	0.8032	0.08032	0.16064	0.24096	0.32128
300	1.2048	0.12048	0.24096	0.36144	0.48192

Length (in feet)	Resistance Ω	Voltage Drop per Conductor			
		@ 0.1 A	@ 0.2 A	@ 0.3 A	@ 0.4 A
400	1.6064	0.16064	0.32128	0.48192	0.64256
500	2.008	0.2008	0.4016	0.6024	0.8032
600	2.4096	0.24096	0.48192	0.72288	0.96384
700	2.8112	0.28112	0.56224	0.84336	1.12448
800	3.2128	0.32128	0.64256	0.96384	1.28512
900	3.6144	0.36144	0.72288	1.08432	1.44576
1000	4.016	0.4016	0.8032	1.2048	1.6064
1100	4.4176	0.44176	0.88352	1.32528	1.76704
1200	4.8192	0.48192	0.96384	1.44576	1.92768
1300	5.2208	0.52208	1.04416	1.56624	2.08832
1400	5.6224	0.56224	1.12448	1.68672	2.24896
1500	6.024	0.6024	1.2048	1.8072	2.4096
1600	6.4256	0.64256	1.28512	1.92768	2.57024
1700	6.8272	0.68272	1.36544	2.04816	2.73088
1800	7.2288	0.72288	1.44576	2.16864	2.89152
1900	7.6304	0.76304	1.52608	2.28912	3.05216
2000	8.032	0.8032	1.6064	2.4096	3.2128
2100	8.4336	0.84336	1.68672	2.53008	3.37344
2200	8.8352	0.88352	1.76704	2.65056	3.53408
2300	9.2368	0.92368	1.84736	2.77104	3.69472
2400	9.6384	0.96384	1.92768	2.89152	3.85536
2500	10.04	1.004	2.008	3.012	4.016
2600	10.4416	1.04416	2.08832	3.13248	4.17664
2700	10.8432	1.08432	2.16864	3.25296	4.33728
2800	11.2448	1.12448	2.24896	3.37344	4.49792
2900	11.6464	1.16464	2.32928	3.49392	4.65856
3000	12.048	1.2048	2.4096	3.6144	4.8192
3100	12.4496	1.24496	2.48992	3.73488	4.97984
3200	12.8512	1.28512	2.57024	3.85536	5.14048
3300	13.2528	1.32528	2.65056	3.97584	5.30112
3400	13.6544	1.36544	2.73088	4.09632	5.46176
3500	14.056	1.4056	2.8112	4.2168	5.6224
3600	14.4576	1.44576	2.89152	4.33728	5.78304

Length (in feet)	Resistance Ω	Voltage Drop per Conductor			
		@ 0.1 A	@ 0.2 A	@ 0.3 A	@ 0.4 A
3700	14.8592	1.48592	2.97184	4.45776	5.94368
3800	15.2608	1.52608	3.05216	4.57824	6.10432
3900	15.6624	1.56624	3.13248	4.69872	6.26496
4000	16.064	1.6064	3.2128	4.8192	6.4256
4100	16.4656	1.64656	3.29312	4.93968	6.58624
4200	16.8672	1.68672	3.37344	5.06016	6.74688
4300	17.2688	1.72688	3.45376	5.18064	6.90752
4400	17.6704	1.76704	3.53408	5.30112	7.06816
4500	18.072	1.8072	3.6144	5.4216	7.2288
4600	18.4736	1.84736	3.69472	5.54208	7.38944
4700	18.8752	1.88752	3.77504	5.66256	7.55008
4800	19.2768	1.92768	3.85536	5.78304	7.71072
4900	19.6784	1.96784	3.93568	5.90352	7.87136
5000	20.08	2.008	4.016	6.024	8.032
5100	20.4816	2.04816	4.09632	6.14448	8.19264
5200	20.8832	2.08832	4.17664	6.26496	8.35328
5300	21.2848	2.12848	4.25696	6.38544	8.51392
5400	21.6864	2.16864	4.33728	6.50592	8.67456
5500	22.088	2.2088	4.4176	6.6264	8.8352
5600	22.4896	2.24896	4.49792	6.74688	8.99584
5700	22.8912	2.28912	4.57824	6.86736	9.15648
5800	23.2928	2.32928	4.65856	6.98784	9.31712
5900	23.6944	2.36944	4.73888	7.10832	9.47776
6000	24.096	2.4096	4.8192	7.2288	9.6384
6100	24.4976	2.44976	4.89952	7.34928	9.79904
6200	24.8992	2.48992	4.97984	7.46976	9.95968
6300	25.3008	2.53008	5.06016	7.59024	10.12032
6400	25.7024	2.57024	5.14048	7.71072	10.28096
6500	26.104	2.6104	5.2208	7.8312	10.4416
6600	26.5056	2.65056	5.30112	7.95168	10.60224

Determining the Total Load Current

The following example demonstrates the process for determining the total load current of the FireNET L@titude Fire Alarm Control Panel:

1. Identify the current draw of each device on the circuit connection.
2. Add the device currents together in each circuit connection.
3. Compare the sum of the device currents with the current limit of each circuit connection to verify that the summed level is below the current limit value.
4. Add the device load currents together that were obtained for each of the circuit connections:

Circuit Connection	Maximum Current Limit	Example Load Current
SLC Loop 1	400 mA	150 mA
SLC Loop 2	400 mA	50 mA
AUX 24V	900 mA	0
NAC 1	2.5 A	750 mA continuous DC
NAC 2	2.5 A	925 mA continuous DC
Total Device Load		1.875 A

5. Add the **Total Device Load** to the no-load alarm current to obtain the **Total Load Current**.
6. Total Device Load + FireNET L@titude Fire Alarm Control Panel No-Load = Total Load Current

$$1.875 + 200 \text{ mA} = 2.075 \text{ A}$$

$$\text{Total Load Current} = 2.075 \text{ A}$$

7. Verify that the current level is below 4 Amps: $2.075 \text{ A} < 4 \text{ A}$
8. This example demonstrates that device loading does not exceed the 4 Amp capacity of the power supply.

1.25 A of the 5.25 A power supply is reserved for battery charging.

Refer to Specifications for the maximum current limits provided in the example calculation above.

Determining the Standby Battery Capacity

This section provides guidelines for determining the standby battery rating. For power supply applications that do not include fire alarm equipment, alarm current is the dynamic current present during operation of the power supply. Standby current is the static current present when the power supply is not operating an alarm.

Battery Rating Equation

The equation below describes the method for determining the amp hour rating of the standby batteries:

$$\text{Battery Rating} = (\text{Battery De-Rating Factor}) \times [(\text{Standby amp hours}) + (\text{Alarm amp hours})]$$

OR

$$\text{Battery Rating} = (\text{Battery De-Rating Factor}) \times [(\text{24 hours} \times \text{Standby-Current}) + (\text{5 Minutes} \times \text{Alarm Current})]$$

where the battery de-rating factor = 1.2 and 5 minutes = 5 / 60 minutes = 1/12 = .0833 hours

To determine the amp hour rating of standby batteries:

1. Record the standby current of the power supply.
2. Record the standby current of the fire control panel. This current includes the LCD Main Processor Board, the Main Back Board, System A Panel Module, and System B Panel Module. It does not include current of the power supply and circuit boards in Slots C through F.
3. Record the standby current of circuit boards populating Slots C through F.
4. Record the standby current of SLC, NAC, and auxiliary devices.
5. Total standby currents.
6. Record the alarm current of the power supply.
7. Record the alarm current of the fire control panel. This current includes the LCD Main Processor Board, the Main Back Board, System A Panel Module, and System B Panel Module. It does not include current of the power supply and circuit boards in slots C through F.
8. Record the alarm current of circuit boards populating slots C through F of the panel.
9. Record the alarm current of SLC, NAC, and auxiliary devices.
10. Total alarm currents.
11. Multiply the total standby current with the standby-time of 24, 48, or 72 hours to provide the result in amp hours.
12. Multiply the total alarm current with the alarm time 5 or 15 minutes to provide the result in amp hours.
13. Combine the sum of amp hours for total standby and alarm.
14. Determine the minimum required amp hour capacity of the standby battery by multiplying the combined Amp hours with the 1.2 de-rating factor.

15. Select a battery with a capacity rating equal or greater than the minimum required amp hour capacity determined from this calculation.

Amp Hour Rating

Complete the worksheet below to tabulate the total current load and to determine the minimum required amp hour rating of the standby batteries. Select a corresponding standby battery based on these calculations:

	Category	Instruction	Standby Current	Alarm Current
1	Power Supply Standby Current	Current of the power supply with AC input failure.	80 mA	
2	Fire Control Panel Standby Current	Current of the fire control panel with AC input failure.	Amps	
3	Panel Module Standby Current	Current from panel modules in slots C through F with Standby and AC input failure.	Amps	
4	External Device Standby Current	Current of SLC, NAC, and auxiliary devices with Standby and AC input failure.	Amps	
5	Total Standby Current	Total all standby currents.	Amps	
6	Power Supply Alarm Current	Current of the power supply with Alarm and AC input failure.		80 mA
7	Fire Control Panel Alarm Current	Current of the fire control panel with Alarm and AC input failure.		Amps
8	Panel Module Alarm Current	Current from panel modules in slots C through F with Alarm and AC input failure.		Amps
9	External Device Alarm Current	Current of SLC, NAC, and auxiliary devices with Alarm and AC input failure.		Amps
10	Total Alarm Current	Total all alarm currents.		Amps
11	Standby Amp Hours	Multiply total standby current with 24, 48, or 72 hours to provide the result in amp hours.	Amp Hours	
12	Alarm Amp hours	Multiply total alarm current with 5 or 15 minutes to provide the result in Amp hours: 5 minutes = .0833 hours 15 minutes = .25 hours		Amp Hours
13	Sum Standby and Alarm Amp Hours	Combine the sum of amp hours for total standby and alarm.	Amp Hours	
14	Standby Battery Amp Hour	Multiply the combined amp hours with the de-rating factor	Amp	

	Category	Instruction	Standby Current	Alarm Current
	Capacity	of 1.2	Hours	

Supervising Station Requirements for Combination Systems

Due to system constraints, the use of a supervising station is required when the L@titude panel is used for providing Carbon Monoxide detection.

INDEX

0

0V 45, 59, 88, 96

1

10.25 19, 106, 122, 145, 164

14 AWG 102, 126, 166

16 AWG 165

18 AWG 166

2

24V 24, 60, 80, 96, 101, 106, 130, 147,

164

5

5.25 19, 105-106, 122, 145, 164

A

AC Normal 27, 109, 117

AUX 24V 34, 64, 80, 130, 163-164

B

Battery Discon 27

Battery Low 59, 110

Black Box 149

Buzzer 44, 58, 97, 111

C

Cabling 18, 101, 121, 165

Class A 15, 37, 59, 80, 128, 150

Class B 38, 59, 80, 128

Class X 31, 65, 87

Communication Modules 145

Current Limits 164

D

DC Out On 27, 110

Display Test 54

Dual Loop 19, 59, 78, 93, 124, 147

E

EOLR 42

Event Log 54, 134

F

Fascia 18, 66, 74, 97, 118, 135

Fire In Zone 74

Fire Relay 43, 60, 81, 111, 131

Fire Routing Input 60, 132

Fire Routing Output 1 45, 87, 131

Fire Routing Output 2 60, 111, 132

Fuse 148

G

General Trouble 67, 107, 112

H

Heartbeat 27, 60, 109

	I	Prog Routing Output 46, 60, 133
IDC 85, 93, 147		S
	J	SLC 15, 37, 58, 84, 93, 127, 164
J1 25		Slot C 79
	K	Slot D 84
Keyswitch 151		Slot E 85
	L	Slot F 85
Lamp & Buzzer Test 53		Standby Batteries 18, 102, 107, 115, 122, 164
LCD Main Processor Board 19, 66, 97, 118, 147, 187		Standby Battery 26, 73, 107, 115, 125, 186
Load Current 185		Superv Relay 43, 60, 81, 131
Loop Explorer 2 44, 64		T
	M	Terminals 18, 59, 80, 101, 115, 122, 150, 165
Main Back Board 19, 61, 78, 90, 118, 125, 147, 185		Trouble 27, 58, 81, 107, 111, 116, 123
	N	Trouble Relay 43, 81, 107, 112, 131
NAC 59, 80, 93, 125, 146, 164		Trouble Routing Input 133
Network 31, 87, 125, 145, 164		Trouble Routing Output 60, 133
	P	Z
Panel Tests 53		Zone LED 20, 65, 97, 111, 118, 125
Printer 20, 65, 75, 97, 118, 125, 146		
Prog Inputs 132		
Prog Routing Input 1 60, 132 Prog		
Routing Input 2 60, 133		