



Radar Fall Detection Sensor

VS373

User Guide



Safety Precautions

Milesight will not shoulder responsibility for any loss or damage resulting from not following the instructions of this operating guide.

- ❖ The device must not be disassembled or remodeled in any way.
- ❖ To avoid risk of fire and electric shock, do keep the product away from rain and moisture before installation.
- ❖ Do not place the device where the temperature is below/above the operating range.
- ❖ **Do not touch the device directly to avoid the scalds when the device is running.**
- ❖ The device must never be subjected to shocks or impacts.
- ❖ Make sure the device is firmly fixed when installing.
- ❖ Do not expose the device to where laser beam equipment is used.
- ❖ Use a soft, dry cloth to clean the device.
- ❖ **The device is intended only as an auxiliary tool and cannot fully replace manual monitoring or personal companionship.** For details please refer to [Disclaimer and Important Information](#).

Declaration of Conformity

VS373 is in conformity with the essential requirements and other relevant provisions of the CE, FCC, and RoHS.

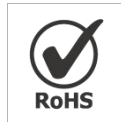

Copyright © 2011-2025 Milesight. All rights reserved.

All information in this guide is protected by copyright law. Whereby, no organization or individual shall copy or reproduce the whole or part of this user guide by any means without written authorization from Xiamen Milesight IoT Co., Ltd.

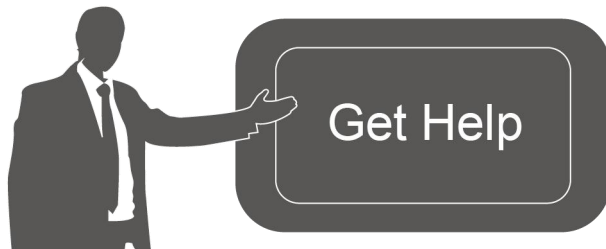

For assistance, please contact

Milesight technical support:

Email: iot.support@milesight.com

Support Portal: support.milesight-iot.com

Tel: 86-592-5085280

Fax: 86-592-5023065

Address: Building C09, Software Park
Phase III, Xiamen 361024,
China

Revision History

Date	Doc Version	Description
Jan. 22, 2025	V1.0	Initial version

Contents

1. Product Introduction	5
1.1 Overview	5
1.2 Key Features	5
2. Hardware Introduction	6
2.1 Packing List	6
2.2 Hardware Overview	6
2.3 DO Wiring	7
2.4 Button and LED Descriptions	7
2.5 Dimensions (mm)	7
3. Power Supply	8
4. Access the Sensor	9
5. Installation Instruction	10
5.1 Scenario Recommendation	10
5.2 Installation Location	10
5.3 Installation Steps	11
5.4 Factors Affecting Accuracy	13
6. Operation Guide	13
6.1 Rule	13
6.1.1 General Settings	14
6.1.2 Sub Regions	19
6.1.3 Information	21
6.2 Communication	22
6.2.1 LoRa	22
6.2.2 Milesight D2D Settings	25
6.2.3 WLAN	27
6.3 System	28
6.3.1 Device	28
6.3.2 User	29
6.3.3 Maintenance	30
7. Communication Protocol	31
7.1 Basic Information	31
7.2 Sensor Data	32
7.3 Downlink Commands	34
7.4 Historical Data Enquiry	38

1. Product Introduction

1.1 Overview

VS373 is a Radar Fall Detection Sensor that adopts a Millimeter Wave Radar to capture falling. It provides non-contact person detection through point cloud data and realizes fall alarms. With a fall detection accuracy rate of up to 99%, it ensures the safety of users.

As a Milesight D2D controller & agent, the VS373 seamlessly communicates with other Milesight D2D devices, establishing more connections and paving the way for smoother operations. It can also be linked with an alarm switch to notify the relevant personnel to take emergency measures.

With easy configuration and wireless detection, VS373 can be integrated with the Milesight LoRaWAN® gateway and Milesight Development Platform, enabling remote and visual management of all sensor data.

VS373 can be used in living rooms, bathrooms, bedrooms, kitchens, hospital wards, care homes, and other spaces where falls may occur.

1.2 Key Features

- Equipped with Millimeter Wave Radar, it can overcome the adverse effects of light and water mist, which make it able to penetrate some obstacles
- Equipped with a millimeter-wave MIMO array antenna (24 Transmitters & 22 Receivers), it can provide higher precision and reliability
- Support continuous 24-hour detection and management capabilities, it does not rely on visible light and can operate stably both day and night
- Support fall detection with a 99% fall capture rate and less than 1% false alarm rate
- Support add sub regions for independent occupancy detection
- Support in-bed detection, leaving the bed within the scheduled time will trigger an alarm
- 100% privacy protection, no images will be captured
- Support on-site alarms with a buzzer and LED indicator and provide backend reporting of alarm information, enabling timely notification of any emergency
- Support Milesight D2D protocol to enable ultra-low latency and direct control without gateways
- Support management via Milesight Development Platform

2. Hardware Introduction

2.1 Packing List

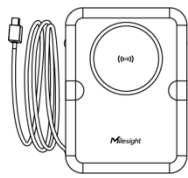

1 × VS373 Device

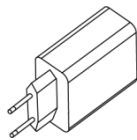

1 × Type-C Power Adapter

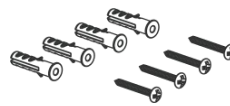

4 × Ceiling Mounting Kits

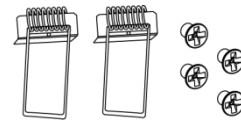

2 × Spring Clips



2 × Silicone Plugs



1 × DO Wiring



1 × Quick Guide



1 × Warranty Card

⚠ If any of the above items is missing or damaged, please contact your sales representative.

2.2 Hardware Overview

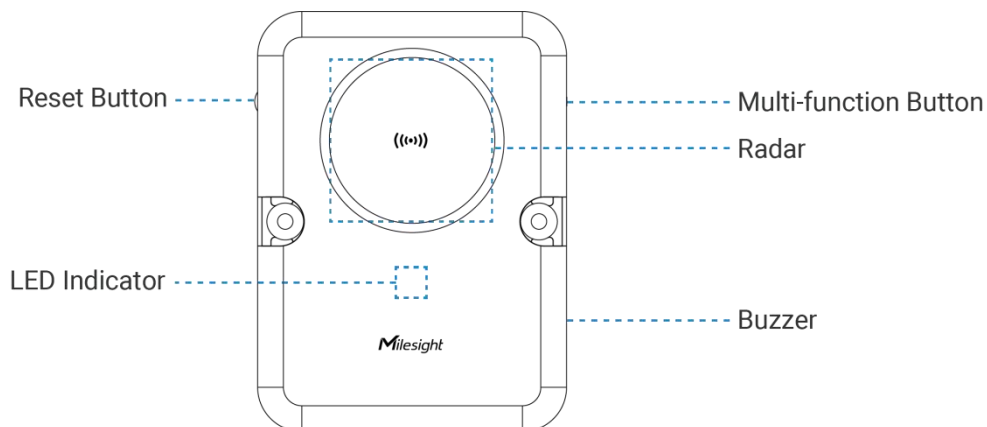

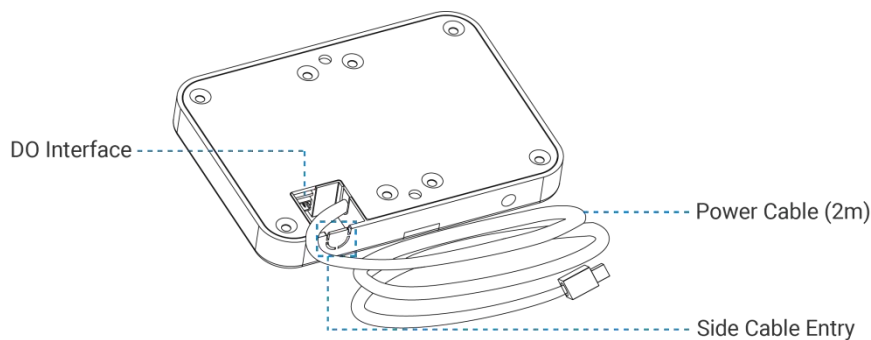

2.3 DO Wiring

When the fall alarm is confirmed, the DO will trigger a high level (connected) until the alarm is released.

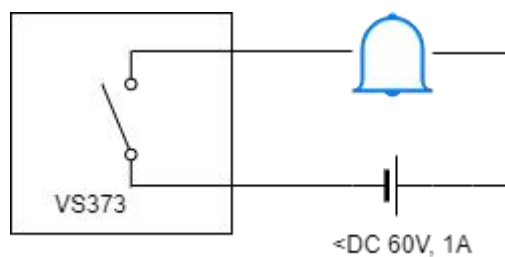

2.4 Button and LED Descriptions

Note: it is necessary to remove the silicone plug from the reset button before pressing it.

Function	Action & Description	LED Indication
Turn On/Off Wi-Fi	Short press the Multi-function button once	Wi-Fi On: Light on
		Wi-Fi Off: Blink Slowly
Turn On Radar	Radar Initializing	Blink Quickly
Reset to Factory Default	Press and hold the reset button for 10 seconds	Blink Quickly
Fall Alarm	Fall event occurred	Blink Quickly
Stop Alarm	Press and hold the reset button for 6~9 seconds	Light On or Blink Slowly
Device Abnormality	Radar anomaly; WiFi anomaly	Light On

2.5 Dimensions (mm)

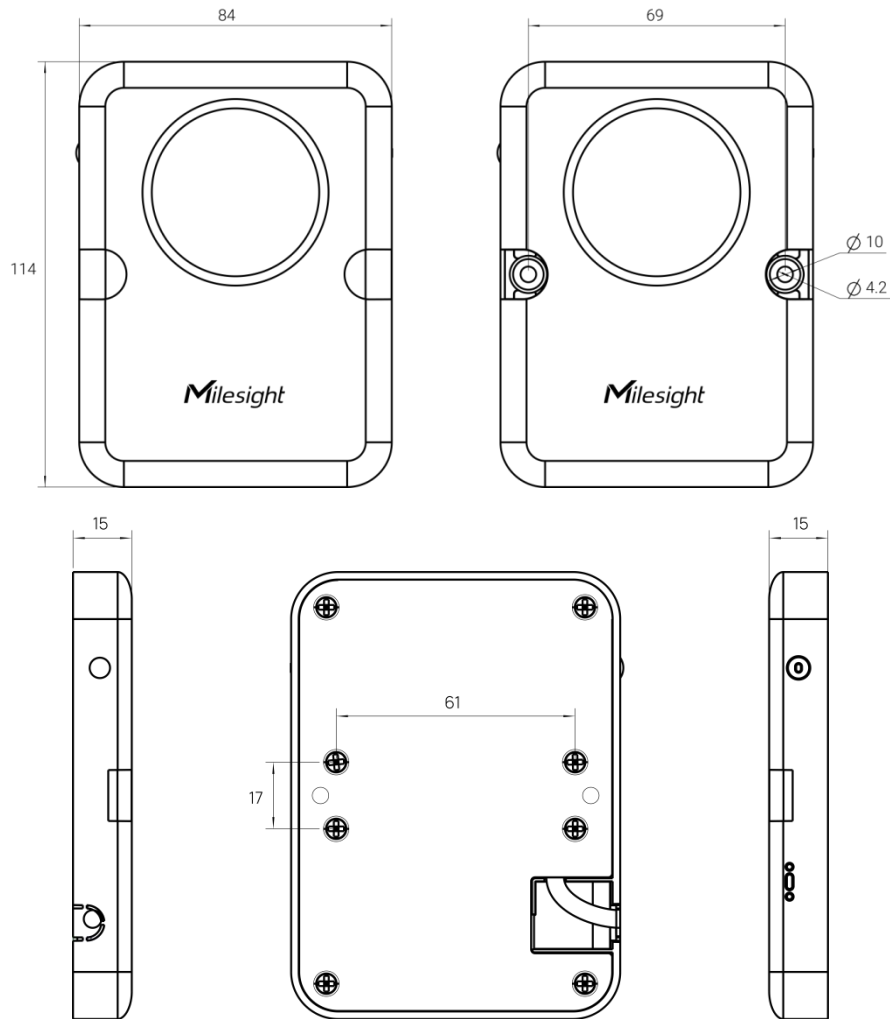

3. Power Supply

- Powered by Type-C Power Adapter (5V, 3A)

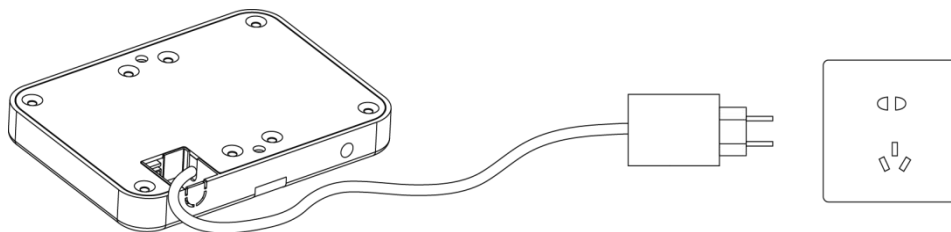

Note: If the default power cable length (2m) does not suit your application, please add a Type-C extension cable and ensure the length of extension cable matches the formula below:

$$R * 3A \leq 5V - 4.2V$$

Where:

R—Cable Resistance in Ω , refer to [Wire Resistance Calculator](#).

4. Access the Sensor

VS373 provides a user-friendly web GUI for configuration access via Wi-Fi. The default settings are as below:

Wi-Fi SSID: **Fall Detection_xxxxxx** (can be found on the device label)

Wi-Fi IP: **192.168.1.1**

Step 1: Enable the Wireless Network Connection on your computer, search for the corresponding Wi-Fi SSID to connect it, then enter 192.168.1.1 to access the web GUI.

Step 2: Users need to set a password and three security questions when using the sensor for the first time.

The screenshot displays two web forms side-by-side. The left form is titled 'Activation' and contains fields for 'User Name' (with 'admin' entered), '* Password' (with 'Please Input'), and '* Confirm Password' (with 'Please Input'). Below these fields are instructions: 'At least: 8 characters' and '2 types of characters: Number, letter and symbol'. A blue button with a right-pointing chevron is at the bottom. The right form is titled 'Set Security Questions' and contains three sections. Each section has a dropdown menu for a security question (e.g., 'What is your lucky number?'), an asterisk, and an input field for the answer (e.g., 'Please Input'). A blue button with a checkmark is at the bottom.

Step 3: After configuration, log in with the username (admin) and the custom password.

Note:

- 1) Password must be 8 to 16 characters long and contain at least two of the following: numbers, lowercase letters, uppercase letters and special characters.
- 2) It is recommended that users regularly update their passwords to enhance device security and prevent unauthorized access.
- 3) You can click "forgot password" in login page to reset the password by answering the three

security questions when you forget the password if you set the security questions in advance.

5. Installation Instruction

5.1 Scenario Recommendation

Recommendation	Scenarios
Most Recommended	Bedrooms (10-20 m ²) with enough walking space
	Hospital rooms (Active area of every patient: 8-20 m ²)
	Residential toilets (4-15 m ²)
	Public toilets (every cubicle: 3-5 m ²)
	Accessible toilets (≥ 4.5 m ²)
Medium Recommended	Narrow spaces ($\geq 2 \times 2$ m ²)
	Places in environments with large metal objects, large mirrors or large glass doors
	Places with ceiling fans
Not Recommended	Factories/warehouses where there are a large number of metal brackets, moving trolleys and other interfere with radar detection
	Outdoor applications with multiple detection targets and multiple interference factors
	Hotels or conference rooms where fall detection is not a primary requirement
	Narrow spaces under 2×2 m ²

Note:

- 1) The reference area size is for 1 device unit. If your rooms are large, please install multiple units.
- 2) If your scenarios are not listed above, please enquire Milesight for details.

5.2 Installation Location

Installation Height: 2.3~3m.

Installation Location: Ensure the center of radar placed in the center of detection area. Take a room without any objects as example, place the device on the ceiling with the center of radar matching the center of the room. The long side of the device should align with the longer dimension of the room, while the short side should align with the shorter dimension of the room.

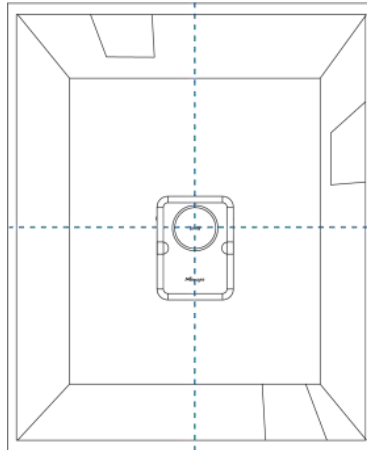
**Note:**

- If the centered position of the room ceiling is not suitable for mounting the device, find a proper position that is at least 1 meter away from the wall..
- Ensure the installation location of the device is flat and stable to avoid tilting or instability.
- Avoid installing the device near ceiling fans or chandeliers.
- Minimize the accumulation of cabinets or clutter within the device's detection range, and avoid the presence of large metal surfaces, mirrors, or other reflective objects nearby.
- The room size, installation height, and detection height should be accurately measured using tools such as a rangefinder or tape measure before setting.

5.3 Installation Steps

Ceiling Mount

Step 1: Drill 2 holes with a diameter of 6mm according to the hole positions of the device screws. Then screw the wall plugs into the ceiling.

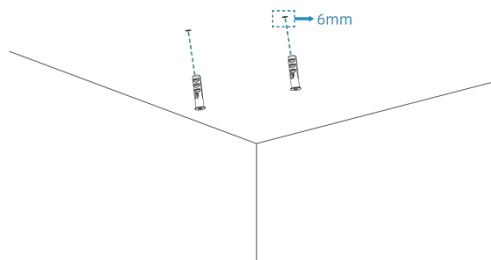

Note: If you need to hide the power cord inside the ceiling, drill an additional hole for the wire.

Step 2: Cut a side wire hole according to the mark on the device, and thread the power cable through the side wire hole.

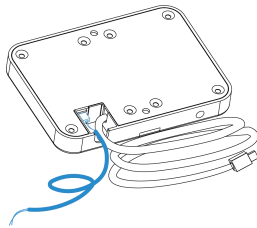

Note: If the DO wiring is going to be used, please connect the DO wiring to the device, then pass it through the side wire hole.

Step 3: Fix the device to the wall plugs using the mounting screws.

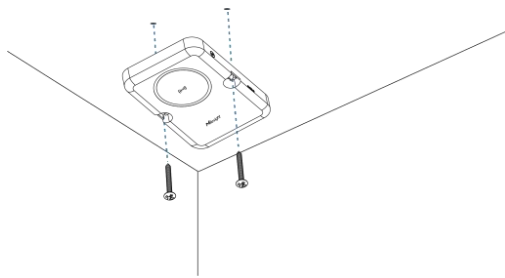

Step 4: Install the silicone plugs.

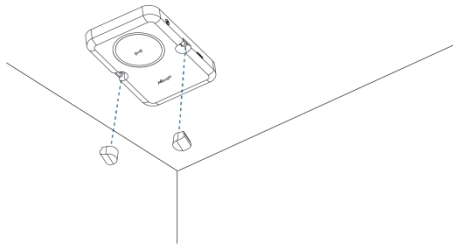

Cutout Mount

Step 1: Drill a hole with a diameter of 76.3~80mm in the ceiling.

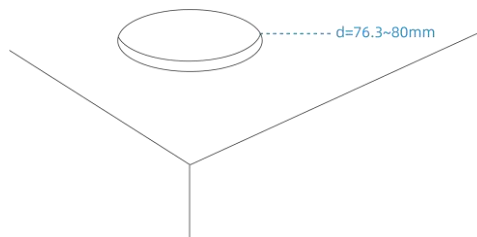

Step 2: Fix the spring clips to the device with screws.

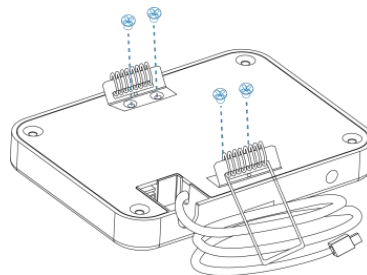

Step 3: Cut a side wire hole according to the mark of the device, and thread the power cable through the side wire hole.

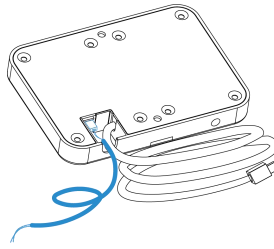

Note: If the DO wiring is going to be used, please connect the DO wiring to the device, then pass it through the side wire hole.

Step 4: Place both sides of the spring clip vertically into the hole by hand.

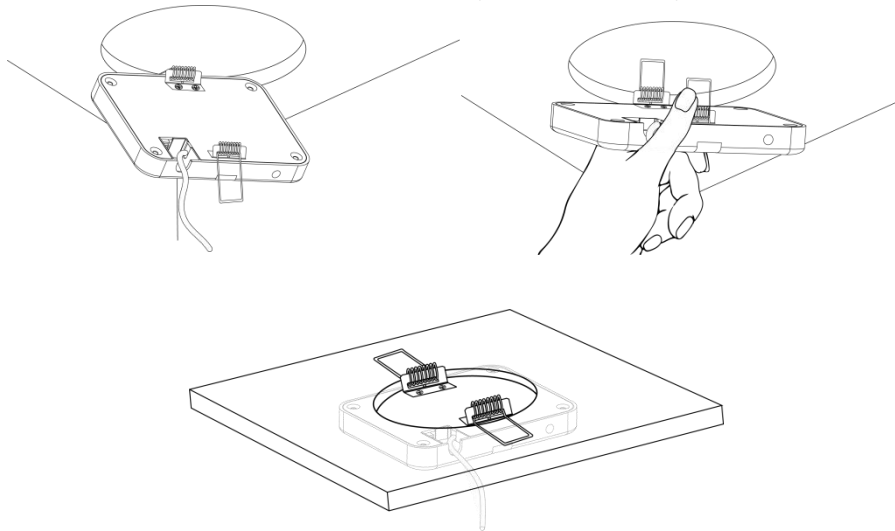

5.4 Factors Affecting Accuracy

- The device only supports single-person fall detection. The fall event of more than one person will not be detected.
- The fall event occurring outside the detection space will not be detected.
- When the distance between the device and the wall is less than 1m, it is possible to cause miss detection or error detection.
- If there are large mirrors, glass, or similar objects in the detection area, it can cause multi-path effects, leading to reduced detection accuracy of the radar.
- When the following objects appear in the detection space, they may be mistakenly identified as a fall event and trigger an alarm: a robot vacuum, pets, a low oscillating fan, or a person lying on the floor resting or playing.

6. Operation Guide

6.1 Rule

6.1.1 General Settings

Step 1: Define the cuboid detection space of fall detection by configuring the distance coordinates with the center of the radar as the origin, the space detection height, and the device installation height.

Note:

- 1) These parameters should be accurately measured using tools such as a rangefinder or tape measure before setting; otherwise, it could cause missed detection or false detection.
- 2) If there is a large piece of glass or any other interfering objects around the detection space, exclude them by adjusting the x/y distance parameters.
- 3) If there is ceiling fan or any high objects above the detection space, exclude them by adjusting the zMax parameter.

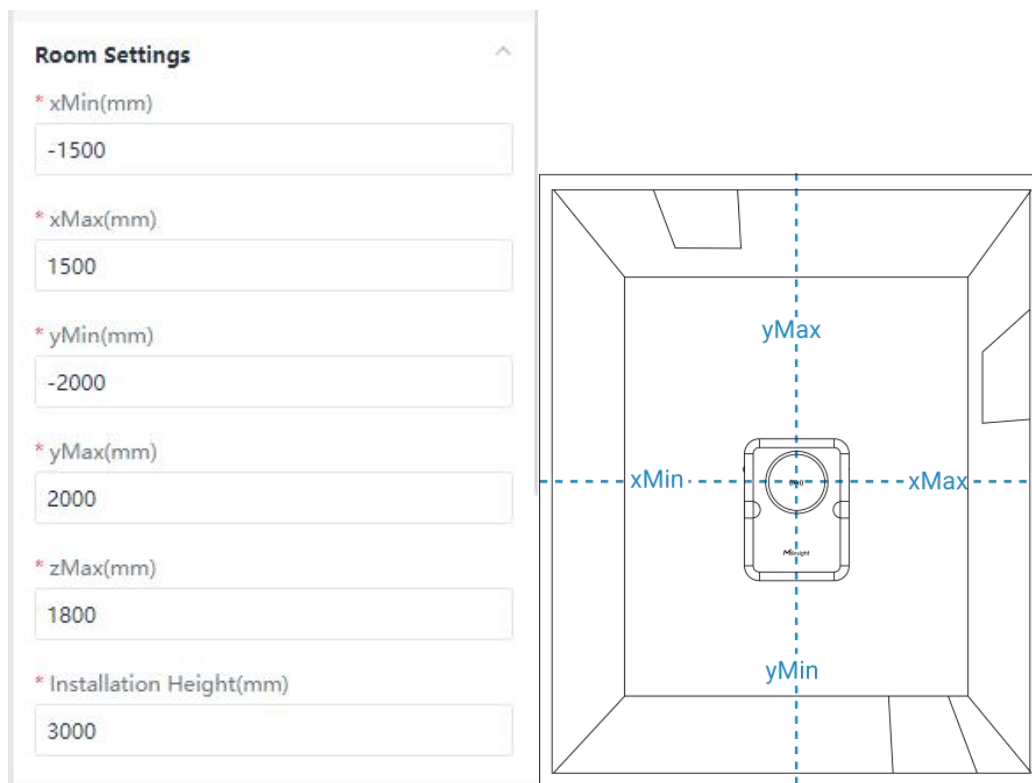

Step 2: Set the sensitivity and the time parameters for fall detection.

Basic Settings ^

Sensitivity

High v

Fall Detection

* Fall Confirmation Time(s)

50

* Fall Delay Reporting Time(s)

40

* Fall Alarm Duration(s)

30

Parameters	Description
Sensitivity	<p>The ability of radar to detect and identify target.</p> <p>High: Select when there are fewer interfering objects in the detection space and accurate detection of smaller or more distant targets is required.</p> <p>Low: Select to reduce false alarms when there are more interfering objects in the detection space or when the environment is more complex.</p>
Fall Detection	<p>The process of Fall Detection:</p> <p>Stage 1: Target altitude change detected. The red light blinks slowly and the duration will depend on the Fall Confirmation Time you set. The alarm can be canceled at this stage by standing.</p> <p>Stage 2: The fall event is confirmed. The LED will blink red quickly and the buzzer start sounding for a duration that depends on the Fall Delay Reporting Time. The alarm can be canceled at this stage by standing. The alarm data will not report in this stage.</p> <p>Stage 3: An alarm message will be reported. The LED will still blink red quickly and the buzzer will sound for a duration that depends on the Fall Alarm Duration. The alarm cannot be canceled at this stage by standing, but can resolved by clicking Handle button on the Information page.</p>

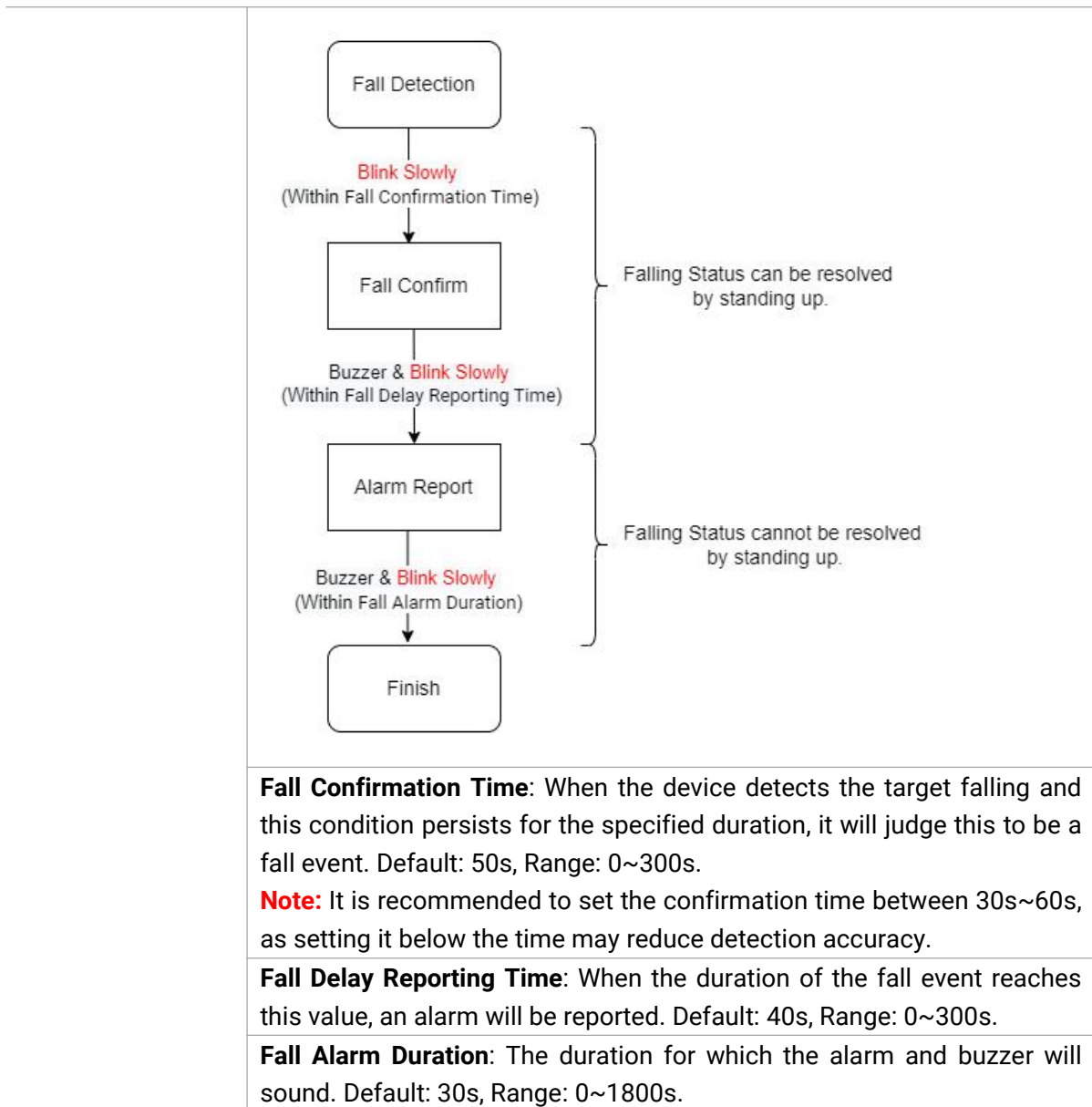

Step 3 (Alternative): Configure below parameters as required to reduce the miss detection.

Occupancy Detection

* Occupancy Time Threshold(min)

Motionless Detection

* Motionless Time Threshold(min)

LED

Buzzer

Parameters	Description
Occupancy Detection	<p>Enable or disable this feature to know the occupancy status in the whole detection space.</p> <p>Occupancy Time Threshold (min): An alarm will be triggered when the stay time of the target in the detection space reaches this value.</p> <p>Note:</p> <ol style="list-style-type: none"> 1) When the target remains stationary or leaves, the radar can not be recognized, so it is recommended to increase the door sub region to determine the stay of the target through the entry and exit events. 2) The alarm will be resolved when you leave the detection space or manually clicking Handle button on the Information page.
Motionless Detection	<p>Enable or disable this feature to know the movement status of target in the whole detection space.</p> <p>Motionless Time Threshold(min): An alarm will be triggered when the duration of no movement by the target reaches this value.</p> <p>Note:</p> <ol style="list-style-type: none"> 1) The function can only be performed when the detection space is in an occupied status. 2) It is recommended to increase the door sub regions for accurate detection. 3) The alarm will be resolved when the target moves or manually clicking Handle button on the Information page.
LED	Enable or Disable indicator light for fall detection alarm
Buzzer	Enable or Disable buzzer sounding for fall detection alarm.

Step 4: After configuring all the detection parameters, click **Apply** to wait 1~2minutes for the point to reappear on the axes in the **Information** page.

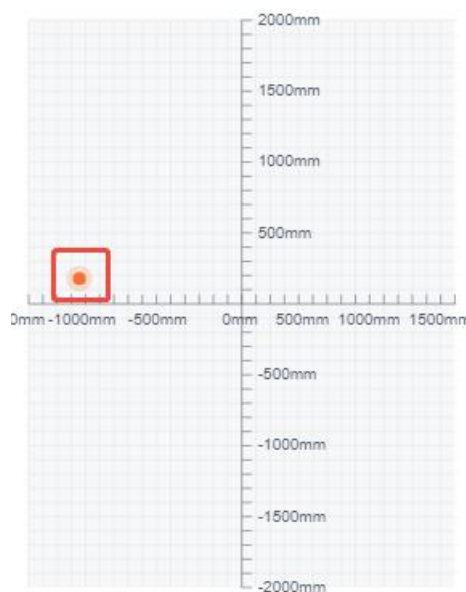

Step 5: Test if the fall detection takes effect on the spot.

- 1) Enter the detection space and walk around for 20s.

- 2) Start to fall in a certain posture, then check if the LED slowly blinks red.
- 3) After maintaining the falling posture for the Fall Confirmation Time (50s by default), check if the LED quickly blinks red and if the buzzer sounds.
- 4) Stand up to check if the LED will stop blinking and the buzzer will stop sounding. Or keep falling posture for the Fall Delay Reporting Time (40s by default) to check if the device reports the fall alarm to network server.
- 5) After reporting the fall alarm, exit the detection space to recover the device to normal detection status.

Note: There is not need to exit the detection space if you stand up after 3) to release the alarm.

- 6) Replicate above steps with different falling postures or locations in the detection space.

Step 6: If there is still missed or erroneous after adjusting the parameters, click **Start Recording** and reproduce the issue by Step 5, then click **Stop Recording** to download the log files and provide them to Milesight technical support for troubleshooting.



Advanced Settings

Set the time for target appearance and target disappearance. Usually you can keep these settings at their default values.

 A screenshot of a settings dialog box titled 'Advanced Settings'. Under the 'Targets Detection' section, there are two input fields. The first is labeled '* Presence Confirmation Time(s)' and contains the value '3'. The second is labeled '* Absence Confirmation Time(s)' and contains the value '5'.

Parameters	Description
Presence Confirmation Time(s)	When the target appearance time reaches this value, it is recognized as present in the area.
Absence Confirmation Time(s)	When the target disappearance time reaches this value, the target is recognized as having disappeared from the area.

6.1.2 Sub Regions

VS373 supports the configuration of sub regions to achieve more detailed monitoring and alert settings for specific locations, enhancing the overall accuracy and flexibility of monitoring.

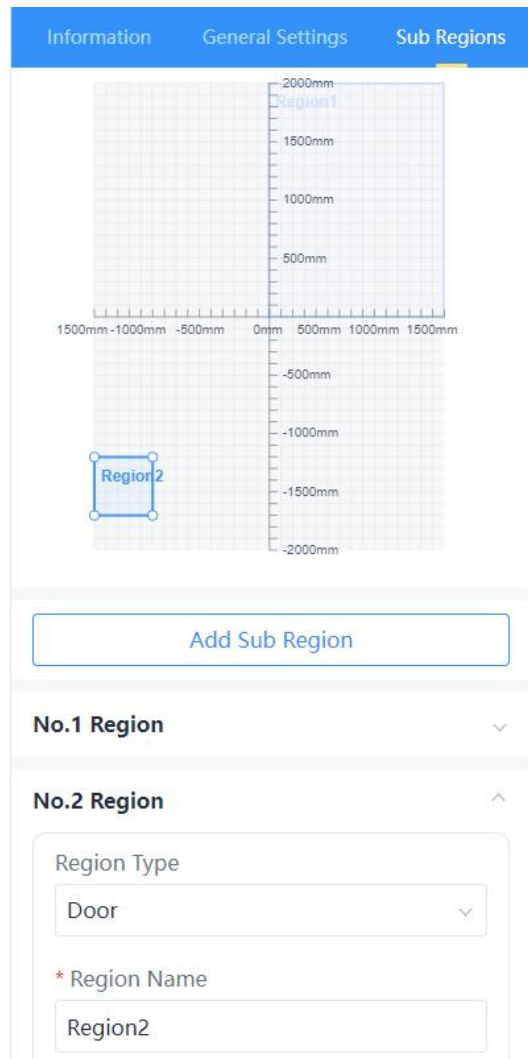

Step 1: Click **Add Sub Region**. One device supports to add up to 4 sub regions.

Step 2: Select the region type and configure the related parameters.

Parameters	Description
Region Type	<p>Default, Door and Bed are optional.</p> <p>Default: select this option if the sub region is not close to the edge of the detection space. Example: fan, ceiling fan, etc.</p> <p>Door: select this option if the sub region is close to the edge of the detection space. Example: door</p> <p>Bed: select this option if requiring to monitor the target status in bed.</p> <p>Sub Region Example:</p>

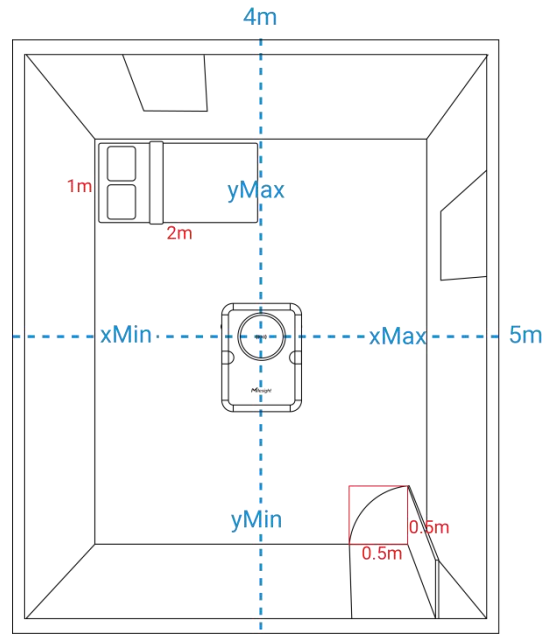

Region Name	Custom a unique region name.													
xMin / xMax	Configure the coordinate parameters of this sub region. You can also adjust these parameters by dragging or zooming in/out the region on the above view.													
yMin / yMax														
Fall Detection	Enable or disable fall detection in this sub region.													
	<table border="1"> <thead> <tr> <th>Whole Space</th> <th>Sub Region</th> <th>Result</th> </tr> </thead> <tbody> <tr> <td>√</td> <td>√</td> <td>Only one fall alarm message will be sent.</td> </tr> <tr> <td>√</td> <td>×</td> <td>The fall detection of this sub region will be blocked.</td> </tr> </tbody> </table>	Whole Space	Sub Region	Result	√	√	Only one fall alarm message will be sent.	√	×	The fall detection of this sub region will be blocked.				
	Whole Space	Sub Region	Result											
√	√	Only one fall alarm message will be sent.												
√	×	The fall detection of this sub region will be blocked.												
Occupancy Detection	Enable or disable to know the occupancy status is in this sub region.													
	<table border="1"> <thead> <tr> <th>Whole Space</th> <th>Sub Region</th> <th>Result</th> </tr> </thead> <tbody> <tr> <td>√</td> <td>√</td> <td>Only one occupancy alarm message will be sent.</td> </tr> <tr> <td>√</td> <td>×</td> <td>The occupancy detection of this sub region will be blocked.</td> </tr> <tr> <td>×</td> <td>√</td> <td>The occupancy detection of this sub region will be enabled.</td> </tr> </tbody> </table>	Whole Space	Sub Region	Result	√	√	Only one occupancy alarm message will be sent.	√	×	The occupancy detection of this sub region will be blocked.	×	√	The occupancy detection of this sub region will be enabled.	
	Whole Space	Sub Region	Result											
	√	√	Only one occupancy alarm message will be sent.											
√	×	The occupancy detection of this sub region will be blocked.												
×	√	The occupancy detection of this sub region will be enabled.												
Motionless Detection	Enable or disable to know the movement status in this sub region. This option only display when Motionless Detection is enabled in General settings.													
	<table border="1"> <thead> <tr> <th>Whole Space</th> <th>Sub Region</th> <th>Result</th> </tr> </thead> <tbody> <tr> <td>√</td> <td>√</td> <td>Only one motionless alarm message will be sent.</td> </tr> <tr> <td>√</td> <td>×</td> <td>The motionless detection of this sub region will be blocked.</td> </tr> </tbody> </table>	Whole Space	Sub Region	Result	√	√	Only one motionless alarm message will be sent.	√	×	The motionless detection of this sub region will be blocked.				
	Whole Space	Sub Region	Result											
√	√	Only one motionless alarm message will be sent.												
√	×	The motionless detection of this sub region will be blocked.												
In-bed Detection	Enable or disable to know the target in-bed status.													

Bed Height: the height of bed.

In-bed Detection Period: set the in-bed detection working time period.

Out of Bed Time Threshold: When the time for the target getting away from the bed reaches this value, an alarm is triggered.

6.1.3 Information

After finishing the settings, user can see all the information as following.

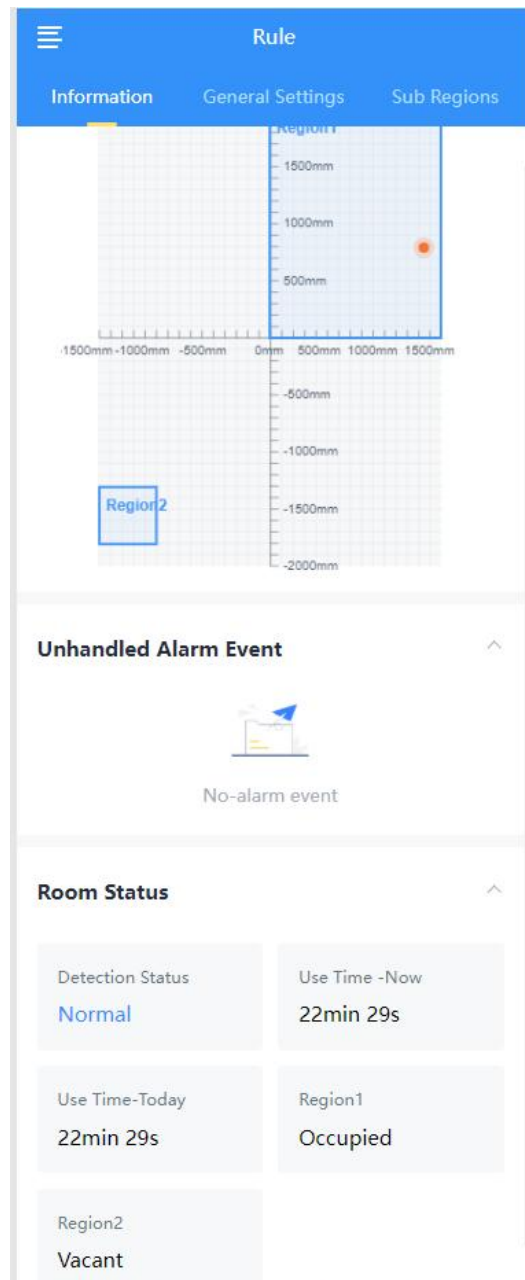

Parameters	Description
Coordinate Axis	Display all the sub regions and the location of target.
Unhandled Alarm Event	Display all unprocessed alarm messages.

Room Status	Detection Status	Display the current status of target. There are five states in total: Normal , Vacant , In-bed , Out of Bed , and Fall .
	Use Time-Now	Length of time this room area was occupied.
	Use Time-Today	Cumulative hours of occupancy of the room area for the day. Refreshes every day at 00:00.
	RegionX	Displays Vacant when the coordinate point is not in the sub region; displays Occupied when the coordinate point is in the sub region.

6.2 Communication

6.2.1 LoRa

Report Settings

Report Settings	
Status Report Period	- 10 +
Occupied	<input type="checkbox"/>
Vacant	<input type="checkbox"/>
Fall Alarm	<input checked="" type="checkbox"/>
Out of Bed Alarm	<input checked="" type="checkbox"/>
Occupancy Alarm	<input checked="" type="checkbox"/>
Motionless Alarm	<input type="checkbox"/>
Data Retransmission	<input type="checkbox"/>

Parameters	Description
Status Report Period	The interval of reporting regional usage and alarm data to network server. Default: 10 min, Range: 1 ~ 1440 min
Alarm Type	Enable or disable the reporting of corresponding alarms when they are triggered.
Data Retransmission	After enabling, if the LoRa connection is lost and data cannot be transmitted, automatically store the data for that period and immediately push the data once the connection is restored. Note: It is necessary to enable the Rejoin Mode for this feature.

LoRaWAN Settings

Configure AppEUI, Join Type, Application Key, and other information. You can also keep all settings by default.

LoRaWAN Settings ^

Lora Status Activated

Device EUI 24E124806E483996 ❏

* APP EUI

24E124C0002A0001

* Application Port

85

Join Type

OTAA v

Parameters	Description
LoRa Status	LoRaWAN® network joining status of this device.
Device EUI	Unique ID of the device which can also be found on the label.
App EUI	The default App EUI is 24E124C0002A0001.
Application Port	The port is used for sending and receiving data, the default port is 85.
Device Type	It's fixed as Class C.
Join Type	OTAA and ABP modes are available.
Application Key	Appkey for OTAA mode, the default is 5572404C696E6B4C6F52613230313823.
Network Session Key	Nwkskey for ABP mode, the default is 5572404C696E6B4C6F52613230313823.
Application Session Key	Appskey for ABP mode, the default is 5572404C696E6B4C6F52613230313823.
Device Address	DevAddr for ABP mode, the default is the 5th to 12th digits of the SN.
Rejoin Mode	Reporting interval ≤ 35 mins: the device will send a specific number of LinkCheckReq MAC packets to the network server every reporting interval or every double reporting interval to validate connectivity; If there is no response, the device will re-join the network. Reporting interval > 35 mins: the device will send a specific number of

	<p>LinkCheckReq MAC packets to the network server every reporting interval to validate connectivity; If there is no response, the device will re-join the network.</p> <p>Note: Only OTAA mode supports rejoin mode.</p>
Number of Detection	<p>When the rejoin mode is enabled, set the number of LinkCheckReq packets to send.</p> <p>Note: the actual sending number is Number of Detection + 1.</p>
LoRaWAN® Version	V1.0.2 and V1.0.3 are available.
Supported Frequency	<p>Enable or disable the frequency to send uplinks.</p> <p>* Support Frequency</p> <p>EU868</p> <p>Frequency/MHz</p> <p>868.1 <input type="checkbox"/></p> <p>868.3 <input type="checkbox"/></p> <p>868.5 <input type="checkbox"/></p> <p>867.1 <input type="checkbox"/></p> <p>867.3 <input type="checkbox"/></p> <p>If frequency is one of CN470/AU915/US915, enter the index of the channel that you want to enable and make them separated by commas.</p> <p>Examples:</p> <p>1, 40: Enabling Channel 1 and Channel 40</p> <p>1-40: Enabling Channel 1 to Channel 40</p> <p>1-40, 60: Enabling Channel 1 to Channel 40 and Channel 60</p> <p>All: Enabling all channels</p> <p>Null: Indicate that all channels are disabled</p>
RX2 Data Rate	RX2 data rate to receive downlinks.
RX2 Frequency	RX2 frequency to receive downlinks. Unit: Hz
Spreading Factor	If ADR is disabled, the device will send data via this spread factor.
Confirmed Mode	If the device does not receive an ACK packet from the network server, it will resend data once.
ADR Mode	Allow network server to adjust the data rate of the device.

6.2.2 Milesight D2D Settings

Milesight D2D protocol is developed by Milesight and used for connections among Milesight devices without a gateway reducing latency and achieving quick control

D2D Setting

Enable

D2D Data Rate(RX2) DR0 (SF12, 125k)

D2D Frequency(RX2) 869.525000

* D2D Key

5572404C696E6B4C6F52613230313823

Milesight D2D Controller

When D2D setting is enabled, VS373 can work as a Milesight D2D controller device to send commands to trigger Milesight D2D agent devices.

1. Configure RX2 datarate, RX2 frequency and D2D key in LoRaWAN® settings. It is suggested to change the default RX2 frequency to avoid conflicts with other devices and set RX2 datarate **between SF7 and SF10** to ensure better performance.

Communication

LoRa D2D WLAN

RX2 Data Rate

DR0 (SF12, 125k)

* RX2 Frequency

869.525000

2. Enable **D2D Settings**, and set the D2D key to be the same as the setting in D2D agent devices. (Default D2D Key: 5572404C696E6B4C6F52613230313823)
3. Enable the trigger conditions and define different 2-byte hexadecimal control commands (0x0000 to 0xffff).

Example: When motionless alarm is triggered, VS373 will send a D2D command 0004 to trigger the Milesight D2D agent devices to take actions within 5 minutes.

D2D Controller Settings ^

Occupied

Vacant

Fall Alarm

Out of Bed Alarm

Occupancy Alarm

Motionless Alarm

* Control Command

4

Control Time(min)

* Input time(min)

5

Milesight D2D Agent

When D2D setting is enabled, VS373 can work as a Milesight D2D agent device to receive commands from Milesight D2D controller devices.

1. Ensure the RX2 datarate and RX2 frequency in LoRaWAN settings are the same as the D2D controller devices.

☰
Communication

LoRa
D2D
WLAN

RX2 Data Rate

DR0 (SF12, 125k) v

* RX2 Frequency

869.525000

2. Enable **D2D Settings**, and set the D2D key to be the same as the setting in D2D controller device. (Default D2D Key: 5572404C696E6B4C6F52613230313823)
3. Define different 2-byte hexadecimal control commands (0x0000 to 0xffff) and command actions. At most 3 actions can be added.

Example: after receiving D2D command 0x1510 from Milesight D2D controller devices, the VS373 will trigger the multi-function button to enable Wi-Fi.

D2D Agent Settings

* Control Command
1510

* Action Object
Multi-function Button

* Action Event
Enable Wi-Fi

+ Continue to add(1/3)

6.2.3 WLAN

WLAN Setting

Enable

* Wi-Fi SSID
Fall Detection_XXXXXX

* WLAN IP Address
192.168.1.1

Wi-Fi Password

* Password
Please Input

Hide Wi-Fi
Hide this Wi-Fi so it can only be connected to manually

Parameters	Description
Enable	Enable or disable Wi-Fi feature. This can also be turned on/off via multi-function button.
Wi-Fi SSID	The unique name for this device Wi-Fi access point, defined as Fall Detection_xxxxxx (can be found on the device label).
WLAN IP Address	Configure WLAN IP address for web access, the default IP address

	is 192.168.1.1.
Wi-Fi Password	Customize the password when security mode is not No Encryption.
Hide Wi-Fi	Hide this Wi-Fi so that it cannot be discovered; the SSID must be manually entered to connect.

6.3 System

6.3.1 Device

Device Info

All information about the hardware and software can be checked on this page.

Device Info	
Model	VS373-868M
SN	6806E48399660001
Software Version	V_373.1.0.1-b
Hardware Version	V1.0
MAC Address	24:E1:24:88:27:66

Synchronize Time

Synchronize Time	
Device Time	27/12/2024 14:14:02
Time zone	UTC+8:00 China Standard Time (CT/CST) ▾
Synchronize Mode	<input checked="" type="radio"/> Gateway Timing <input type="radio"/> Manual Timing

Parameters	Description
Device Time	Display the current time.
Time Zone	Choose the current time zone.
Synchronize Mode	Gateway Timing: Synchronize the system time with embedded network server of Milesight gateway when LoRaWAN® version is 1.0.3. The device will sync the time with gateway once per day or everytime re-joining the network. Manual Timing: Choose to automatically synchronize with the browser time

or manually set the time.

6.3.2 User

User Info



Securit Question

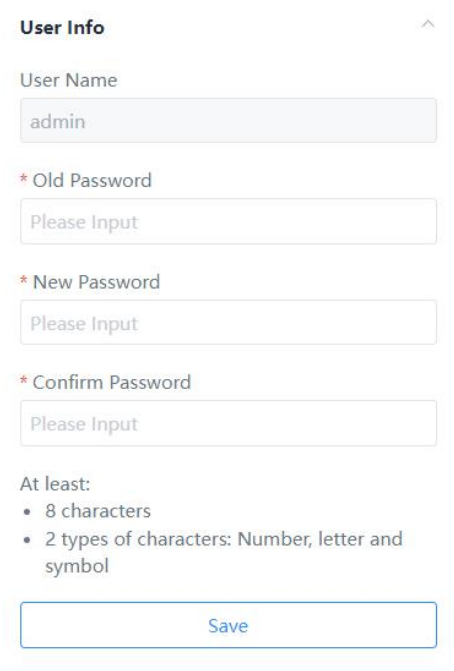

Parameters	Description
User Info	<p>You can change the login password of this device.</p> 
Security Question	<p>Click to set three security questions for your device. In case that you forget the password, you can click Forget Password button on login page to reset the password by correctly answering three security questions correctly.</p>

Security Question ^

Already Set

*** Password**

Security Question 1

 v

*** Answer 1**

Security Question 2

 v

*** Answer 2**

Security Question 3

 v

*** Answer 3**

6.3.3 Maintenance

Data

Historical Data

Reset

Basic Configuration Reset

Factory Data Reset

Reboot

Reboot the Device

Parameters	Description
Data	Click to select the data time range and view the historical data. Choose Export to export data. The maximum export data period is 14 days.

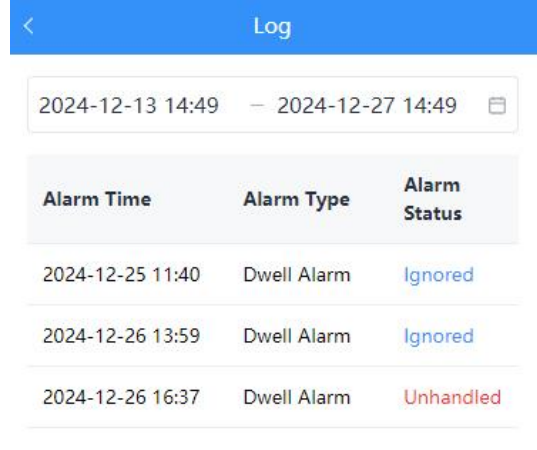
	 <p>The screenshot shows a 'Log' interface with a date range filter from 2024-12-13 14:49 to 2024-12-27 14:49. Below the filter is a table with columns 'Alarm Time', 'Alarm Type', and 'Alarm Status'. The table contains three entries: two 'Dwell Alarm' events on 2024-12-25 and 2024-12-26, both marked as 'Ignored', and one 'Dwell Alarm' event on 2024-12-26 marked as 'Unhandled'.</p>
Reset	<p>Basic Configuration Reset: keep the IP settings and user information when resetting.</p> <p>Factory Data Reset: reset device to factory default, requiring admin password verification</p>
Reboot	Restart the device immediately.
Upgrade	<p>Click Browse and select the upgrading file, then click the Upgrade button to upgrade. The update will be done when the system reboots successfully.</p> <p>Note: The upgrade process takes about 1-3 minutes. Do not turn off the power and complete automatic restart after the upgrade.</p>
Backup and Restore	<p>Export Config File: Export configuration file.</p> <p>Import Config File: Click Browse and select the configuration file, click Import button to import configuration file.</p>
Custom Sensitivity	Used to import custom sensitivity files given by Milesight technical support.
Diagnostics	Download log files for troubleshooting.

7. Communication Protocol

All the data is based on the following format (HEX), the Data field should follow the little-endian:

Channel1	Type1	Data1	Channel2	Type2	Data2	Channel 3	...
1 Byte	1 Byte	N Bytes	1 Byte	1 Byte	M Bytes	1 Byte	...

For decoder examples please find files on <https://github.com/Milesight-IoT/SensorDecoders>.

7.1 Basic Information

VS373 sensor reports basic information whenever it joins the network.

Channel	Type	Byte	Description
ff	01(Protocol Version)	1	01=>V1
	16 (Device SN)	8	16 digits
	09 (Hardware Version)	2	01 00 => V1.0

	0a (Firmware Version)	2	01 14 => V1.14
	0f (Device Type)	1	02: Class C

Example:

ff0101 ff166806e39739840003 ff090100 ff0a0101 ff0f02					
Channel	Type	Value	Channel	Type	Value
ff	01(Protocol Version)	01 (V1)	ff	16 (Device SN)	6806e39739840003
Channel	Type	Value	Channel	Type	Value
ff	09 (Hardware Version)	0100 (V1.0)	ff	0a (Firmware Version)	0101 (V1.1)
Channel	Type	Value	Channel	Type	Value
ff	0f (Device Type)	02 (Class C)			

7.2 Sensor Data

Channel	Type	Byte	Description
03	f8(Occupancy Status)	6	<ul style="list-style-type: none"> ● Byte 1: Detection Status, 00-Normal; 01: Vacant; 02-In-bed; 03-Out of Bed; 04-Fall ● Byte 2: Target Status, 00-Normal; 01-Motionless; 02-Abnormal ● Byte 3-4: User Time-Now, Unit: s ● Byte 5-6: User Time-Today, Unit: s
04	f9(Sub Region Occupancy Status)	4	<ul style="list-style-type: none"> ● Byte 1: Sub Region1, 00: Occupied; 01: Vacant ● Byte 2: Sub Region2, 00: Occupied; 01: Vacant ● Byte 3: Sub Region3, 00: Occupied; 01: Vacant ● Byte 4: Sub Region4, 00: Occupied; 01: Vacant
05	fa(Out Of Bed Time)	8	<ul style="list-style-type: none"> ● Byte 1-2: Bed Sub Region1, Unit: s ● Byte 3-4: Bed Sub Region2, Unit: s ● Byte 5-6: Bed Sub Region3, Unit: s

			<ul style="list-style-type: none"> ● Byte 7-8: Bed Sub Region4, Unit: s
06	fb(Alarm)	5	<ul style="list-style-type: none"> ● Byte 1-2: Random ID, Range:0-9999, Motionless/Occupied/Vacant is ffff. ● Byte 3: Alarm Type, 00-Fall; 01: Motionless; 02-Dwell; 03-Out of Bed; 04-Occupied; 05-Vacant ● Byte 4: 01-Alarm; 02-Resolved; 03: Ignore ● Byte 5: Bed Sub Region ID or ff
20	ce(Historical Data)	9	<ul style="list-style-type: none"> ● Byte 1-4: Unix Timestamp ● Byte 5-6: ID, Range:0-9999 ● Byte 7: Alarm Type, 00-Fall; 01: Motionless; 02-Dwell; 03-Out of Bed; 04-Occupied; 05-Vacant ● Byte 8: 01-Alarm; 02-Resolved; 03: Ignore ● Byte 9: Bed Sub Region ID or ff

Examples:

1. Periodic packet:

03f80100e0105046 04f901010101 05fab004000000000000		
Channel	Type	Value
03	f8(Occupancy Status)	01=>Detection Status is Vacant 00=>Target Status is Normal User Time-Now: e010=>10e0=4320s=1h12min User Time-Today: 5046=>4650=18000s=5h
04	f9(Sub Region Occupancy Status)	01 => Sub Region1 is Vacant 01 => Sub Region2 is Vacant 01 => Sub Region3 is Vacant 01 => Sub Region4 is Vacant
05	fa(Out Of Bed Time)	b004=>04b0=1200s=20min, Bed Sub Region1

2. Motionless Alarm packet:

06fb ffff 01 01 ff		
Channel	Type	Value
06	fb(Alarm)	ffff => ID 01 => Motionless 01 => Alarm

3. Dwell Alarm packet:

06fb 1400 0203 ff		
Channel	Type	Value
06	fb(Alarm)	1400 => ID 02 => Dwell 03 => Ignore

4. Out of bed Alarm packet:

06fb 0b00 03 01 00		
Channel	Type	Value
06	fb(Alarm)	0b00 => ID 03 => Out of Bed 01 => Alarm 00 => Sub Region ID

7.3 Downlink Commands

VS373 supports downlink commands to configure the device. The application port is 85 by default.

Channel	Item	Type	Byte	Description
f9	Reboot	10	1	ff
	Room Settings	4f	12	<ul style="list-style-type: none"> Byte 1-2: xMin, UINT16, Unit: mm Byte 3-4: xMax, UINT16, Unit: mm Byte 5-6: yMin, UINT16, Unit: mm Byte 7-8: yMax, UINT16, Unit: mm Byte 9-10: zMax, UINT16, Unit: mm Byte 11-12: Installation Height, UINT16, Unit: mm
	Sensitivity	50	2	00: Low; 01: High
	Fall Detection	51	6	<ul style="list-style-type: none"> Byte 1-2: Fall Confirmation Time, UINT16, Unit: s, Range: 0~300 Byte 3-4: Fall Delay Reporting Time, UINT16, Unit: s, Range: 0~300 Byte 5-6: Fall Alarm Duration, UINT16, Unit: s, Range: 0~1800
	Dwell Time Detection	52	3	<ul style="list-style-type: none"> Byte 1: 01-enable, 00-disable Byte 2-3: Dwell Time Threshold, Unit: min

	Motion Detection	53	3	<ul style="list-style-type: none"> ● Byte 1: 01-enable, 00-disable ● Byte 2-3: Motionless Time Threshold, Unit: min
ff	LED	2f	1	<ul style="list-style-type: none"> ● 01-enable, 00-disable
	Buzzer	3e	1	<ul style="list-style-type: none"> ● 01-enable, 00-disable
	Release Alarm	64	1	ff
f9	Targets Detection	56	2	<ul style="list-style-type: none"> ● Byte 1: Presence Confirmation Time, Unit: s, Range: 0~60 ● Byte 2: Absence Confirmation Time, Unit: s, Range: 0~60
	Sub Region Size	49	9	<ul style="list-style-type: none"> ● Byte 1: Sub Region number, Range 0~3 ● Byte 2-3: xMin, UINT16, Unit: mm ● Byte 4-5: xMax, UINT16, Unit: mm ● Byte 6-7: yMin, UINT16, Unit: mm ● Byte 8-9: yMax, UINT16, Unit: mm
	Delete Sub Region	48	1	Sub Region number, Range 0~3
	Sub Region Detection	4a	5	<ul style="list-style-type: none"> ● Byte 1: Sub Region number, Range 0~3 ● Byte 2: Fall Detection, 01-enable, 00-disable ● Byte 3: Occupancy Detection, 01-enable, 00-disable ● Byte 4: Motion Detection, 01-enable, 00-disable ● Byte 5: Type, 00-Default, 01-Bed, 02-Door
	In-bed Detection	4b	9	<ul style="list-style-type: none"> ● Byte 1: Sub Region number, Range 0~3 ● Byte 2: In-bed Detection, 01-enable, 00-disable ● Byte 3-4: Start time, Unix timestamp ● Byte 5-6: End time, Unix timestamp ● Byte 7-8: Bed Height, Unit: mm ● Byte 9: Out of Bed Time Threshold, Unit: min
ff	Reporting Interval	8e	3	<ul style="list-style-type: none"> ● Byte 1: 00 ● Byte 2-3: interval time, unit: min

	Data Retransmission	69	1	01: Enable, 00: Disable
	Data Retransmission Interval	6a	3	<ul style="list-style-type: none"> ● Byte 1: 00 ● Byte 2-3: Interval time, Unit: s, Range: 30~1200s (600s by default)
	LoRa Confirm Mode	04	1	01: Enable, 00: Disable
	ADR Mode	40	1	01: Enable, 00: Disable
ff	Milesight D2D Feature	84	1	01: enable; 00: disable
	Milesight D2D Key	35	8	First 16 digits, last 16 digits are fixed as 0
	Milesight D2D Settings (controller)	96	8	<ul style="list-style-type: none"> ● Byte 1: <ul style="list-style-type: none"> 00-Occupied 01-Vacant 02-Fall Alarm 03-Out of bed alarm 04-Motionless Alert 05-Dwell Alarm ● Byte 2: 01-enable, 00-disable ● Byte 3: 01-enable LoRa Uplink, 00-disable LoRa Uplink ● Byte 4-5: D2D control command ● Byte 6-7: control time, Unit: min ● Byte 8: 01-enable control time, 00-disable control time
f9	Milesight D2D Settings (agent)	4c	5	<ul style="list-style-type: none"> ● Byte 1: ID, Range: 0~3 ● Byte 2-3: D2D control command ● Byte 4: Action Object, 01 - Multi-function button, 00-Delete this action ● Byte 5: Action Event, 00-Release Alarm, 01-Enable Wi-Fi, 02-Disable Wi-Fi
ff	WLAN	42	1	01: Enable, 00: Disable
f9	Hide Wi-Fi SSID	4d	1	01: Enable, 00: Disable
ff	Synchronize Time	11	4	Unix timestamp
f9	DO	4e	1	01: High, 00: Low

Examples:

1. Reboot the device.

ff10ff		
Channel	Type	Value
ff	10 (Reboot)	ff (Reserved)

2. Set room size.

f9 4f e803 d007 30f8 3cf6 0807 c409		
Channel	Type	Value
f9	4f (Room Setting)	e803=>03e8=1000=> xMin d007=>07d0=2000=> xMax, 30f8=>f820=-2000=> yMin 3cf6=>f63c=-2500=> yMax 0807=>0708=1800=> zMax c409=>09c4=2500=> Installation Height is 2.5m

3. Set Door Sub Region Detection.

f94a 01 01 01 02		
Channel	Type	Value
f9	4a (Sub Region Detection)	01=> Sub Region number 01=> Enable Fall Detection 01=>Enable Occupancy Detection 01=>Motion Detection 02=>Type is Door

4. Set Milesight D2D Key as 5572404C696E6B4C0000000000000000.

ff35 5572404C696E6B4C		
Channel	Type	Value
ff	35 (Set D2D Key)	5572404C696E6B4C

5. Set Milesight D2D controller settings.

ff96 03 01 01 04e0 0500 01		
Channel	Type	Value
ff	96 (D2D Settings)	03=> Out of bed alarm; 01=>Enable; 01=>Enable LoRa Uplink; 04 e0=>e0 04, Control Command is e0 04; 05 00=>00 05, Control time is 5 mins; 01=>Enable Control Time

6. Set Targets Detection Time.

f956 0a 1e		
Channel	Type	Value
f9	56 (Targets Detection)	0a=> 10=>Presence Confirmation Time is 10s 1e=>30=>Absence Confirmation Time is 30s

7.4 Historical Data Enquiry

VS373 supports sending downlink commands to enquire historical data for a specified time point or time range. Before sending these commands, ensure that **the device time is correct and the data storage feature was enabled to store the data.**

Command format:

Channel	Type	Byte	Description
fd	6c (Enquire data in time range)	8	<ul style="list-style-type: none"> Byte 1-4: Start time, Unix timestamp Byte 5-8: End time, Unix timestamp
	6d (Stop query data report)	1	ff
ff	6a (Report Interval)	3	<ul style="list-style-type: none"> Byte 1: 01 Byte 2: Interval time, unit: s, range: 30~1200s (60s by default)

Reply format:

Channel	Type	Byte	Description
fc	6b/6c	1	00: data enquiry success 01: time point or time range invalid 02: no data in this time or time range
20	ce (Historical Data)	9	<ul style="list-style-type: none"> Byte 1-4: Unix Timestamp Byte 5-6: ID, Range:0-9999 Byte 7: Alarm Type, 00-Fall; 01: Motionless; 02-Dwell; 03-Out of Bed; 04-Occupied; 05-Vacant Byte 8: 01-Alarm; 02-Realease; 03: Ignore Byte 9: Bed Sub Region ID or ff

Note:

1. The device uploads no more than 300 data records per range enquiry.
2. When enquiring the data at a specific time point, it will upload the data closest to the search

point within the reporting interval range. For example, if the device's reporting interval is 10 minutes and users send a command to search for data stored at 17:00, it will upload these data, if the device finds any data stored in 17:00. If not, it will search for data between 16:50 to 17:10 and upload the data which is closest to 17:00.

Example:

1. Enquire historical data between 2023/8/28 13:30:00 to 2023/8/28 13:40:00.

fd6c a4aa6367 b4b86367		
Channel	Type	Value
fd	6c (Enquire data in time range)	Start time: a4aa6367 => 6763aaa4 = 1734584996s = 2024/12/19 13:09:56 End time: b4b86367 => 6763b8b4 = 1734588596s = 2024/12/19 14:09:56

Reply:

fc6c00		
Channel	Type	Value
fc	6c (Enquire data in time range)	00: data enquiry success

20ce 7fac6367 17000203ff			
Channel	Type	Time Stamp	Value
20	ce (Historical Data)	7fac6367 => 6763ac7f = 1734585471s = 2024/12/19 13:17:51	1700 => ID 02 => Dwell 03 => Ignore

-END-