

GARMIN®

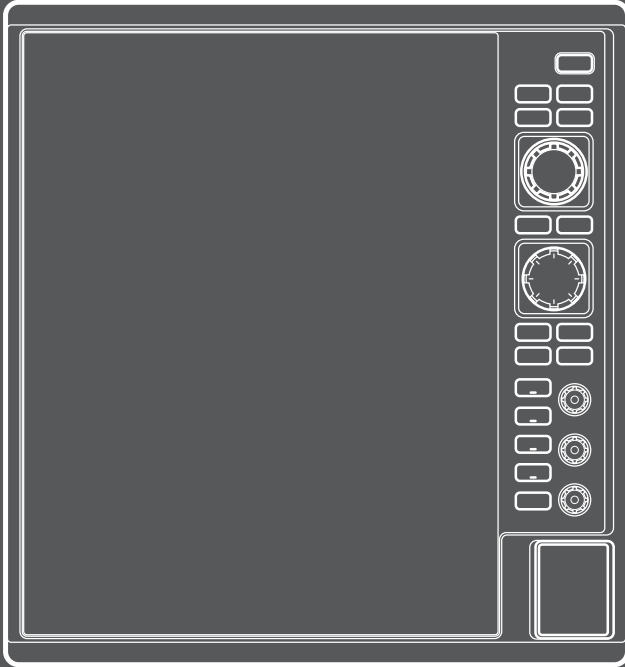

CS 1522

Professional Fishfinder

Owner's Manual

© 2020 Garmin Ltd. or its subsidiaries

All rights reserved. Under the copyright laws, this manual may not be copied, in whole or in part, without the written consent of Garmin. Garmin reserves the right to change or improve its products and to make changes in the content of this manual without the obligation to notify any person or organization of such changes or improvements. Go to www.garmin.com for current updates and supplemental information concerning the use of this product.

Garmin® and the Garmin logo are trademarks of Garmin Ltd. or its subsidiaries, registered in the USA and other countries. Fantom™, FUSION-Link™, Garmin ClearVü™, Garmin Connect™, Garmin Helm™, Garmin LakeVü™, Garmin Quickdraw™, GCV™, GMR™, GRID™, GXM™, HomePort™, MotionScope™, Panoptix™, Shadow Drive™, and SmartMode™ are trademarks of Garmin Ltd. or its subsidiaries. These trademarks may not be used without the express permission of Garmin.

SD™ and the SDHC logo are trademarks of SD-3C, LLC.

NMEA®, NMEA 2000®, and the NMEA 2000 logo are registered trademarks of the National Marine Electronics Association.

Wi-Fi® is a registered mark of Wi-Fi Alliance Corporation.

Windows® is a registered trademark of Microsoft Corporation in the United States and other countries.

All other trademarks and copyrights are the property of their respective owners. Other trademarks and trade names are those of their respective owners.



製造銷售： 台灣國際航電股份有限公司

製造地址： 新北市汐止區樟樹二路68號

電話： (02) 2642-8999

客服專線： (02) 2642-9199

Printed in Taiwan

March 2020

190-02655-2B Rev. C



TABLE OF CONTENTS

CHAPTER 1 INTRODUCTION.....	5
1.1 A Brief History of Sonars	5
1.1.1 Basic Principles of Sonars	5
1.1.2 Development of Sonars.....	5
1.1.3 Determining the Distance.....	5
1.1.4 Locating Fish on a Sonar Display	6
1.2 Specifications	6
1.2.1 NMEA 2000 PGN Information.....	7
1.2.2 NMEA 0183 Information	8
1.3 Inside the Box	9
1.3.1 Device Overview.....	10
1.3.2 Ports	11
1.3.3 Port Pin Definition.....	11
1.4 Installation	12
1.4.1 Typical Configuration.....	12
1.4.2 Tools Needed	12
1.4.3 Mounting Considerations.....	13
1.4.4 Bail Mounting the Device	13
1.4.5 Flush Mounting the Device.....	14
1.5 Thru-Hull Transducer Installation	16
1.5.1 Tools Needed	16
1.5.2 Mounting Considerations.....	16
1.5.3 Fairing Block Angle Cut	17
1.5.4 Cable Considerations	18
1.6 Cable and Connection Considerations.....	18
1.6.1 Power/NMEA 0183 Cable	18
1.6.2 Connecting the Wiring Harness to Power	19
1.6.3 GPS Antenna Considerations.....	20
1.6.4 Connecting the Device to a Transducer	20
1.6.5 GSD Sonar Considerations.....	20
1.6.6 NMEA 2000 Considerations.....	20
1.6.7 NMEA 0183 Connection Considerations.....	21
1.6.8 Lamp and Horn Connections	25
1.7 Control Panel	26
1.8 SD Card	26
1.8.1 Capturing a Screenshot.....	27

1.8.2	Updating the Software.....	27
1.9	Protective Cover.....	27
1.10	Garmin Support Center	28
1.10.1	Registering Your Device	28
CHAPTER 2 GETTING STARTED		29
2.1	Basic Operations.....	29
2.1.1	Powering On/Off.....	29
2.1.2	Stopping the Transmission of the Transducer.....	29
2.1.3	Adjusting the Backlight	29
2.1.4	Switching Display Modes	29
2.2	Display Modes.....	30
2.2.1	Typical Views	30
2.2.2	Sonar Interface Overview	31
2.3	Adjusting the Sonar Display	31
2.3.1	Adjusting the Frequency of the Transducer	31
2.3.2	Adjusting the Range	32
2.3.3	Adjusting the Zoom	32
2.3.4	Hiding Overlay Data and Depth Scale.....	35
2.4	Optimizing the Sonar Display	35
2.4.1	Adjusting Gain.....	35
2.4.2	Adjusting Echo Stretch.....	35
2.4.3	Adjusting Contrast.....	36
2.4.4	Adjusting TVG	36
2.5	Interfacing with the Sonar Display	36
2.5.1	Accessing the Menu	36
2.5.2	Selecting Split Screens.....	37
2.5.3	Invoking the Cursor.....	37
2.5.4	Marking a Waypoint.....	38
2.5.5	Capturing a Screenshot.....	38
2.5.6	Acknowledging and Silencing an Alarm.....	38
2.6	Navigation Chart	39
2.6.1	Navigation Chart Interface.....	39
2.6.2	Navigating to a Point	39
2.6.3	Viewing Information	40
2.7	F1-F4 Shortcuts	41
2.7.1	Using a Shortcut Function.....	41
2.7.2	Swapping an Assigned Function	41

CHAPTER 3 MENU AND SETTINGS..... 43

- 3.1 Accessing the Menu43**
- 3.2 Sonar Setup43**
 - 3.2.1 Adjusting Gain..... 43
 - 3.2.2 Adjusting Contrast..... 44
 - 3.2.3 Adjusting Frequency..... 44
 - 3.2.4 Adjusting Range..... 44
 - 3.2.5 Adjusting Zoom 44
 - 3.2.6 Adjusting Shift 44
 - 3.2.7 Adjusting Scroll Speed 44
 - 3.2.8 Adjusting Bottom Search Limit..... 45
- 3.3 Clutter45**
 - 3.3.1 Reducing Interference 46
 - 3.3.2 Selecting a Color Limit 46
 - 3.3.3 Filtering Colors..... 46
 - 3.3.4 Smoothing Noises 46
 - 3.3.5 Reducing Surface Noise..... 47
 - 3.3.6 Adjusting Echo Stretch..... 47
 - 3.3.7 Adjusting TVG..... 47
- 3.4 Alarms.....48**
 - 3.4.1 Setting a Shallow Water Alarm 48
 - 3.4.2 Setting a Deep Water Alarm..... 48
 - 3.4.3 Setting Water Temperature Alarms 48
 - 3.4.4 Setting Contour Alarms..... 48
 - 3.4.5 Setting Fish Alarms 49
 - 3.4.6 Setting Collision Alarms..... 49
 - 3.4.7 Setting Up Boundaries..... 49
- 3.5 Sonar Appearance.....50**
 - 3.5.1 Changing the Colors 50
 - 3.5.2 Selecting On-Screen Data..... 50
 - 3.5.3 Selecting Views in SideVü Mode 51
- 3.6 Chart Setup51**
 - 3.6.1 Selecting the Chart Orientation..... 52
 - 3.6.2 Personalizing the Chart..... 52
- 3.7 Navigation Info.....52**
 - 3.7.1 Navigating to Coordinates 52
 - 3.7.2 Managing Navigational Data..... 52
 - 3.7.3 Managing Tracks 53

3.8	Other Vessels.....	53
3.8.1	Managing Other Vessels.....	53
3.8.2	AIS.....	54
3.9	Quickdraw Contours.....	55
3.9.1	Mapping a Body of Water.....	55
3.9.2	Adding a Label to a Quickdraw Contours Map.....	55
3.9.3	Garmin Quickdraw Contours Settings.....	56
3.9.4	Garmin Quickdraw Community.....	56
3.10	Navigation Chart Appearance.....	58
3.10.1	Customizing Chart Layers.....	58
3.10.2	Editing Data Panels.....	58
3.11	Settings.....	59
3.11.1	System Settings.....	59
3.11.2	Preferences.....	59
3.11.3	Communications Settings.....	60
3.11.4	My Vessel Settings.....	60
3.11.5	Data Management.....	60

CHAPTER 4 ECHO PATTERNS61

4.1	Surface Noise.....	61
4.2	Colliding Currents.....	61
4.3	Plankton Layers.....	62
4.4	Air Bubbles.....	62
4.5	Side-Lobe Echoes.....	62

CHAPTER 5 APPENDICES..... 63

5.1	Error Message and Troubleshooting.....	63
5.2	Hazardous Substance Table.....	63
5.3	Declaration of Conformity.....	64
5.4	Menu Tree.....	65

CHAPTER 1 INTRODUCTION

WARNING

See the Important Safety and Product Information in the Installation Instructions for product warnings and other important information.

You are responsible for the safe and prudent operation of your vessel. Sonar is a tool that enhances your awareness of the water beneath your boat. It does not relieve you of the responsibility of observing the water around your boat as you navigate.

All route and navigation lines displayed on the device are intended to provide general guidance to identify proper channels, and are not intended to be strictly followed. Always refer to the nav aids and conditions on the water when navigating to avoid groundings or hazards that could result in vessel damage, personal injury, or death.

1.1 A Brief History of Sonars

1.1.1 Basic Principles of Sonars

Sonar, originally an acronym for Sound Navigation and Ranging, is a technology that uses sound propagation to detect objects under the surface of water. Sonar devices determine the distance to objects by sending out sound pulses and measuring the time it takes for the sound pulses to be reflected back.

1.1.2 Development of Sonars

Sonars were developed during the period of the First World War to assist in the detection of submarines and icebergs under water. The technology received major improvements during World War II, and eventually developed into modern fishfinders.

Fishfinders help detect schools of fish by transmitting ultrasonic waves from a transducer mounted on the bottom of the boat, and listens for reflected echoes. The echoes over time can then be plotted on a sonar display in relation to the depths of the water.

1.1.3 Determining the Distance

Fishfinders help detect schools of fish by transmitting ultrasonic waves from a transducer mounted on the bottom of the boat. The pulse would reflect strongly off solid objects like the seafloor, or more weakly off the air conserved in fish bladders. With the speed of sound in water known (roughly 1,500 meters per second), the received echoes over time can then be plotted on a sonar display in relation to the depths of the water.

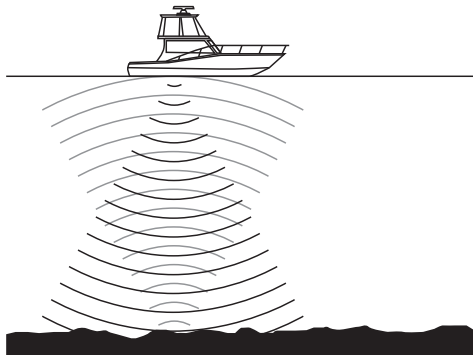

1.1.4 Locating Fish on a Sonar Display

The beam of sound transmitted from the transducer spreads wider as it passes into deeper water, forming a conical shape under the boat. As a fish crosses the cone, the distance between the fish and the transducer would be marked on the sonar display, and since the center of the cone is closest to the transducer, a fish that swims through the cone at a constant depth would form an arch on the sonar display.

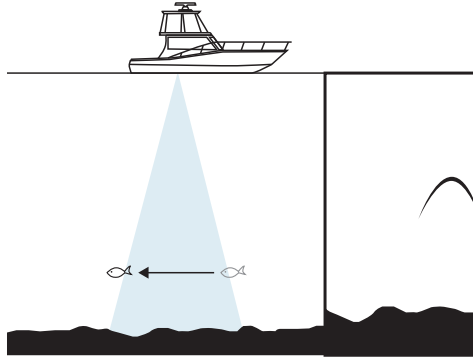

1.2 Specifications

Specification	Measurement
Dimensions (W x H x D)	355 x 376.7 x 82.7 mm
Weight	4.0 kg (6.0 kg with bail mount)
Display size (W x H)	15" (228.1 x 304.1 mm)
Display type	XGA
Display resolution	1024 x 768 pixels
Power supply	10 to 36 VDC
Fuse	8 A, 125 V fast-acting
Max. power consumption at 12 VDC	41.4 W
Typical current draw at 12 VDC	4 A
Max. current draw at 12 VDC	6.5 A
Sonar frequencies*	Traditional: 50/77/200 kHz, dual channel CHIRP ClearVü: 260/455/800 kHz, CHIRP SideVü: 260/455/800 kHz, CHIRP
Sonar transmit power (RMS)**	Traditional: 1 kW Traditional dual channel CHIRP: 1 kW ClearVü CHIRP: 500 W SideVü CHIRP: 500 W
Sonar depth***	5,000 ft at 1 kW
Temperature range	-15° to 50°C (5° to 122°F)
Material	Polycarbonate plastic and die-cast aluminum
Waterproof rating****	IPX6/IPX7 (IEC 60529)
Memory card	2 SD™ card slots; 32 GB max. storage
Max. AIS targets	300
Max. waypoints	5,000

Specification	Measurement
Max. routes	100
Max. saved tracks	50
Chart format	Garmin BlueChart
Interface	2 NMEA 0183, 1 NMEA 2000
Compass-safe distance	65 cm (25.5 in)
NMEA 2000 LEN	2
NMEA 2000 draw	75 mA max.
SW version (as of Dec 2019)	2.0

* Dependent upon transducer.

** Dependent upon transducer rating and depth.

*** Dependent upon the transducer, water salinity, bottom type, and other water conditions.

**** The device is protected against powerful jets of water, and withstands incidental exposure to water of up to 1 m for up to 30 minutes. For more information on water rating, go to Garmin.com/waterrating.

1.2.1 NMEA 2000 PGN Information

Type	PGN	Description
Transmit and receive	059392	ISO acknowledgment
	059904	ISO request
	060928	ISO address claim
	126208	NMEA: Command, request, and acknowledge group function
	126464	Transmit and receive PGN list group function
	126996	Product information
	127250	Vessel heading
	128259	Speed: Water referenced
	128267	Water depth
	129025	Position: Rapid update
	129026	COG and SOG: Rapid update
	129029	GNSS position data
	129540	GNSS satellites in view
	130306	Wind data
130312	Temperature	
Transmit	127258	Magnetic variance
	129283	Cross track error
	129284	Navigation data
	129285	Navigation route and waypoint info
Receive	065030	Generator average basic AC quantities (GAAC)
	126992	System time
	127488	Engine parameters: Rapid update
	127489	Engine parameters: Dynamic
	127493	Transmission parameters: Dynamic
	127504	AC output status
127505	Fluid level	

Type	PGN	Description
Receive	127508	Battery status
	129038	AIS class A position report
	129039	AIS class B position report
	129040	AIS class B extended position report
	129539	GNSS DOPs
	129794	AIS class A static and voyage related data
	129809	AIS class B "CS" static data report, part A
	129810	AIS class B "CS" static data report, part B
	130310	Environmental parameters
	130311	Environmental parameters (obsolete)
	130313	Humidity
	130314	Actual pressure

1.2.2 NMEA 0183 Information

Type	Sentence	Description
Transmit	GPAPB	APB: Heading or track controller (autopilot) sentence "B"
	GPBOD	BOD: Bearing (origin to destination)
	GPBWC	BWC: Bearing and distance to waypoint
	GPGGA	GGA: Global positioning system fix data
	GPGLL	GLL: Geographic position (latitude and longitude)
	GPGSA	GSA: GNSS DOP and active satellites
	GPGSV	GSV: GNSS satellites in view
	GPRMB	RMB: Recommended minimum navigation information
	GPRMC	RMC: Recommended minimum specific GNSS data
	GPRTE	RTE: Routes
	GPVTG	VTG: Course over ground and ground speed
	GPWPL	WPL: Waypoint location
	GPXTE	XTE: Cross track error
	PGRME	E: Estimated error
	PGRMM	M: Map datum
	PGRMZ	Z: Altitude
	SDDBT	DBT: Depth below transducer
	SDDPT	DPT: Depth
	SDMTW	MTW: Water temperature
	SDVHW	VHW: Water speed and heading
	TLL	Target latitude and longitude
	TTM	Tracked target message
	TLB	Target label
	ZDA	Date and time
XDR	Transducer values	
Receive	DPT	Depth
	DBT	Depth below transducer
	MTW	Water temperature

Type	Sentence	Description
Receive	VHW	Water speed and heading
	WPL	Waypoint location
	DSC	Digital selective calling information
	DSE	Expanded digital selective calling
	HDG	Heading, deviation, and variation
	HDM	Heading, magnetic
	MWD	Wind direction and speed
	MDA	Meteorological composite
	MWV	Wind speed and angle
VDM	AIS VHF data-link message	

You can purchase complete information about National Marine Electronics Association (NMEA) format and sentences from: NMEA, Seven Riggs Avenue, Severna Park, MD 21146 USA (www.nmea.org).

1.3 Inside the Box

Check that these items are included in the box.

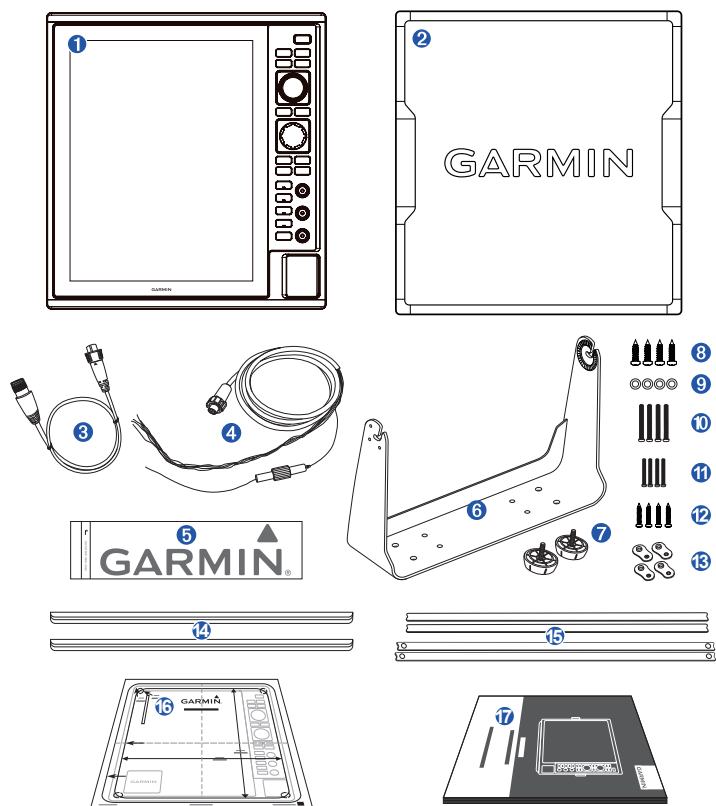

Item	Description	Part Number
①	CS 1522 Display Unit	011-04973-02
②	Protective cover	145-03158-60
③	Power cable (2 m)	320-00458-70
④	12 pin to 8 pin XDCR Adapter Cable	320-00844-01
⑤	Garmin sticker	161-04518-01
⑥	Bail mount bracket	011-04973-90
⑦	Bail mount knob x 2	145-02020-01
⑧	Bail mount screw x 4, M6.3 x 1.8 x 25	211-00171-04
⑨	Bail mount washer x 4	212-20084-00
⑩	Flush mount screw x 4, M4 x 0.7 x 70	211-00210-04
⑪	Flush mount screw x 4, M3 x 0.5 x 60	211-52207-55
⑫	Flush mount screw x 4, TFWM, 4.0 x 25	211-00171-00
⑬	Nut plate x 4	115-01407-50
⑭	Trim piece snap cover x 2	145-03158-50
⑮	Flush mount foam gasket x 4	253-01299-00
⑯	Flush mount template	190-02655-03
⑰	Documentation	K00-01227-01

1.3.1 Device Overview

The Garmin CS 1522 features a 15-inch XGA display, with a control panel, and 2 SD card slots on the side. The CS 1522 can be bail mounted or flush mounted to your boat. Connection to a transducer such as GT40-TM, is required.

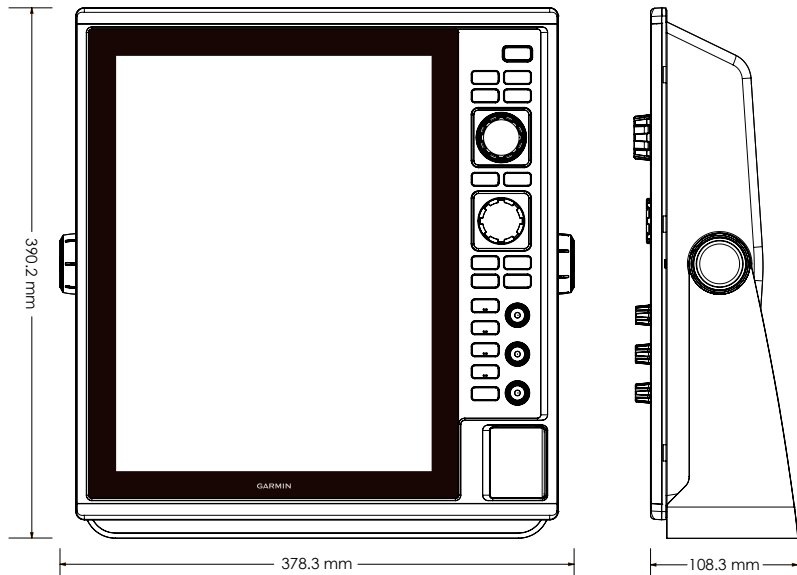

1.3.2 Ports

The ports are located at the back of the device.

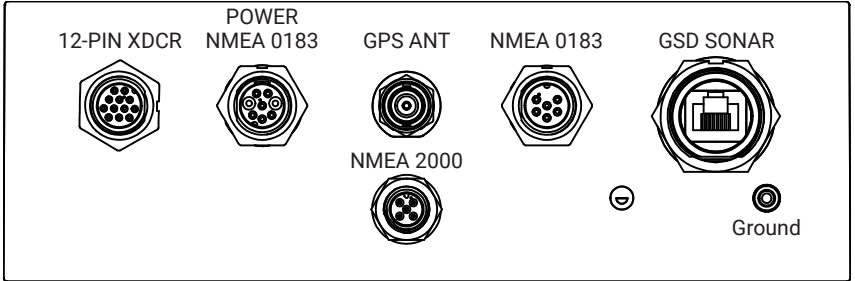

1.3.3 Port Pin Definition

Power Port

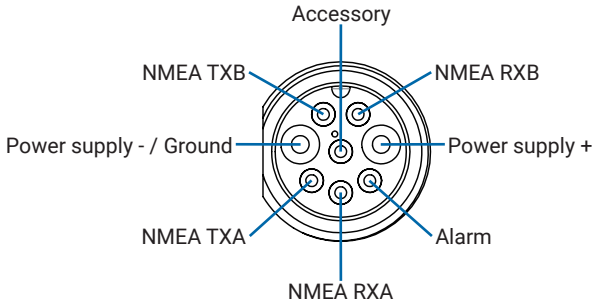

NMEA 0183 Port

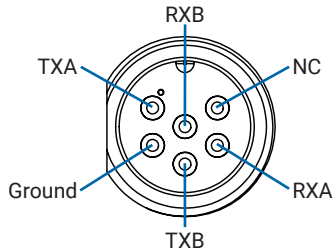

NMEA 2000 Port

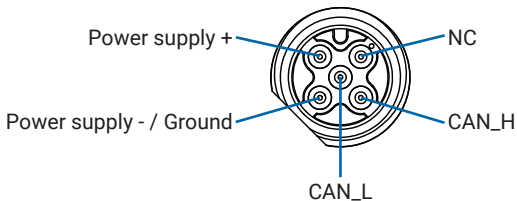

1.4 Installation

⚠ WARNING

When connecting the power cable, do not remove the in-line fuse holder. To prevent the possibility of injury or product damage caused by fire or overheating, the appropriate fuse must be in place as indicated in the product specifications. In addition, connecting the power cable without the appropriate fuse in place voids the product warranty.

⚠ CAUTION

Failure to install and maintain the equipment in accordance with these instructions could result in damage or injury.

Always wear safety goggles, ear protection, and a dust mask when drilling, cutting, or sanding.

NOTICE

When drilling or cutting, always check what is on the opposite side of the surface.

Read all installation instructions before proceeding with the installation. If you experience difficulty during the installation, contact Garmin support.

1.4.1 Typical Configuration

The diagram shows a typical configuration of the device.

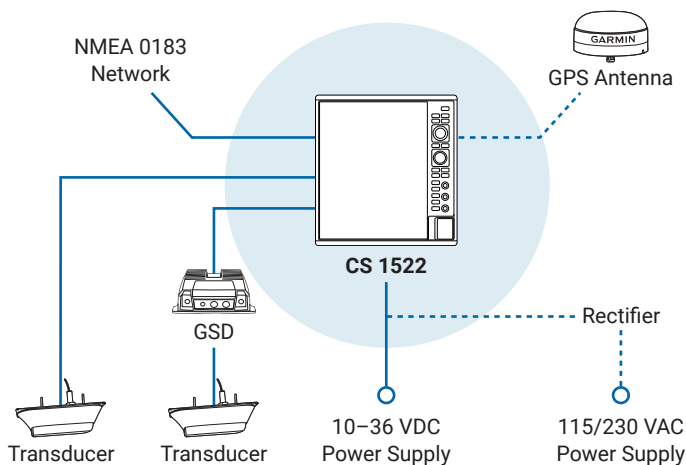

1.4.2 Tools Needed

- Bail mount: drill and drill bits appropriate for the surface and hardware
- Flush mount: drill and 14 mm (9/16 in), 6 mm (1/4 in) and 3.6 mm (9/64 in) drill bits with nut plates, or 3.2 mm (1/8 in) drill bit without nut plates
- #2 Phillips screwdriver
- Jigsaw or rotary tool
- File and sandpaper
- Marine sealant (recommended)

1.4.3 Mounting Considerations

NOTICE

This device should be mounted in a location that is not exposed to extreme temperatures or conditions. The temperature range for this device is listed in the product specifications. Extended exposure to temperatures exceeding the specified temperature range, in storage or operating conditions, may cause device failure. Extreme-temperature-induced damage and related consequences are not covered by the warranty.

When selecting a mounting location, you should observe these considerations:

- The location should be directly in front or slightly to your left as you operate your boat, to provide optimal viewing and allow easy access to all device interfaces, such as the control panel and the SD card slots.
- The location must be strong enough to support the weight of the device and protect it from excessive vibration or shock.
- To avoid interference with a magnetic compass, the device should not be installed closer to a compass than the compass-safe distance value listed in the product specifications.
- The location must allow room for the routing and connection of all cables.

1.4.4 Bail Mounting the Device

NOTICE

If you are mounting the bracket on fiberglass with screws, it is recommended to use a countersink bit to drill a clearance counterbore through only the top gel-coat layer. This will help to avoid cracking in the gel-coat layer when the screws are tightened.

Stainless-steel screws may bind when screwed into fiberglass and overtightened. It is recommended to apply an anti-seize lubricant on the screws before installing them.

You can use the bail mount bracket to bail mount the device on a flat surface.

- 1 Using the bail mount bracket **1** as a template, mark the pilot holes.

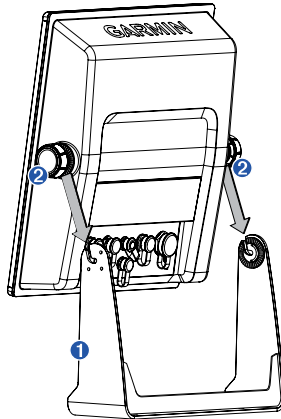

- 2 Using a 3 mm (1/8 in) drill bit, drill the pilot holes.
- 3 Secure the bail mount bracket to the mounting surface using the bail mount screws and washers.
- 4 Install the bail mount knobs **2** on the sides of the device.

- 5 Place the device in the bail-mount and tighten the bail mount knobs.

1.4.5 Flush Mounting the Device

NOTICE

Use the included template and hardware to flush mount the device in your dashboard.

Be careful when cutting the hole to flush mount the device. There is only a small amount of clearance between the case and the mounting holes, and cutting the hole too large could compromise the stability of the device after it is mounted.

- 1 Trim the template, and make sure it fits in the location you want to mount the device.
- 2 Secure the template to the mounting location.
- 3 Using a 14 mm (9/16 in) drill bit, drill one or more of the holes inside the corners of the solid line on the template to prepare the mounting surface for cutting.
- 4 Using a jigsaw or a rotary tool, cut the mounting surface along the inside line on the template.
- 5 Place the device in the cutout to test the fit.
- 6 If necessary, use a file and sandpaper to refine the size of the cutout.
- 7 Use a pry tool, such as a flat piece of plastic or a screwdriver, to carefully pry up the trim caps from the sides, slide the pry tool to the center, and remove the trim caps.

NOTICE

Use a plastic pry tool when possible. Using a metal pry tool such as a screwdriver can damage the trim caps and the device.

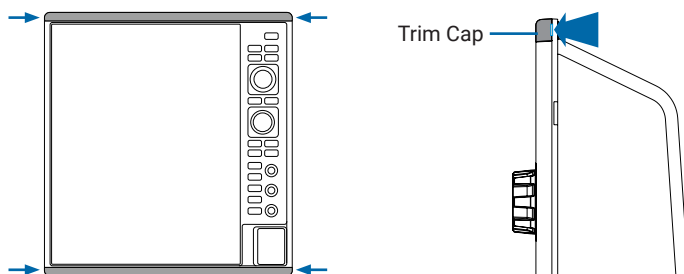

- 8 After the device fits correctly in the cutout, ensure the mounting holes on the device line up with the larger 6 mm (1/4 in) holes on the template.
- 9 If the mounting holes on the device do not line up, mark the new hole locations.
- 10 Select an option:
 - If you are using a nut plate, drill a 6 mm (1/4 in) hole in the larger hole locations.
 - If you are not using a nut plate, drill 3.2 mm (1/8 in) holes in the hole locations.
- 11 Starting in one corner of the template, place a nut plate ① over the larger hole ② drilled in the previous step.

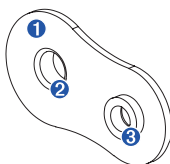

If you are using a nut plate, the smaller hole ③ on the nut plate should line up with the smaller hole on the template.

- 12 If the smaller hole on the nut plate does not line up with the smaller hole on the template, mark the new hole location.
- 13 If you are using a nut plate, drill a 3.6 mm (9/64 in) hole in the smaller hole location.
- 14 Repeat to verify placement of the remaining nut plates and holes on the template.
- 15 Remove the template from the mounting surface.
- 16 Starting in one corner of the mounting location, place a nut plate ④ on the back of the mounting surface, lining up the large and small holes.
The raised portion of the nut plate should fit into the larger hole.

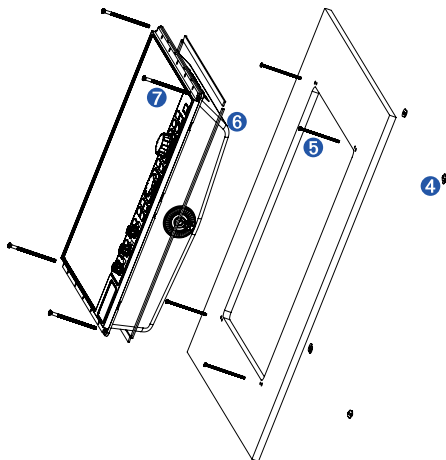

- 17 Secure the nut plates to the mounting surface by fastening the included M3 screws ⑤ through the smaller 3.6 mm (9/64 in) holes.
- 18 Install the foam gasket ⑥ on the back of the device.
The pieces of the foam gasket have adhesive on the back. Make sure you remove the protective liner before installing them on the device.
- 19 If you will not have access to the back of the device after you mount it, connect all necessary cables to the device before placing it into the cutout.

NOTICE

To prevent corrosion of the metal contacts, cover unused connectors with the attached weather caps.

- 20 Apply marine sealant between the mounting surface and the device to properly seal and prevent leakage behind the dashboard.
- 21 If you have access to the back of the device, apply marine sealant around the cutout.
- 22 Place the device into the cutout.
- 23 Secure the device to the mounting surface using the included M4 screws ⑦.
- 24 Wipe away all excess marine sealant.
- 25 Install the trim caps by snapping them in place around the edges of the device.

1.5 Thru-Hull Transducer Installation

⚠ WARNING

After installation, check your boat for leaks before leaving it in the water for an extended period of time.

⚠ CAUTION

Always wear safety goggles, ear protection, and a dust mask when drilling, cutting, or sanding.

Do not install a transducer in the engine compartment or near heat sources.

NOTICE

When drilling or cutting, always check what is on the opposite side of the surface.

The device should be installed by a qualified marine installer.

1.5.1 Tools Needed

- Drill
- 3 mm (1/8 in), 9 mm (3/8 in), 13 mm (1/2 in) drill bits
- fiberglass hull: 25 mm (1 in), 29 mm (1 1/8 in), 32 mm (1 1/4 in) spade bit
- metal hull: 32 mm (1 1/4 in) hole saw
- Band saw or table saw
- Slip-joint pliers or crescent wrench
- Masking tape
- Marine sealant
- Epoxy or exposed core sealant (cored fiberglass hull)

1.5.2 Mounting Considerations

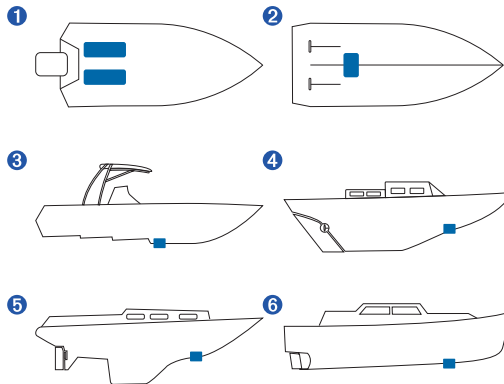

When selecting a mounting location, observe these considerations:

- On outboard and sterndrive vessels ❶, the transducer should be mounted in front of and close to the engine or engines.
- On inboard vessels ❷, the transducer should be mounted in front of and far away from the engine propeller and shaft.
- On step-hull vessels ❸, the transducer should be mounted in front of the first step.
- On full-keel vessels ❹, the transducer should be mounted at a slight angle that aims at the bow, not parallel to the centerline.
- On fin-keel vessels ❺, the transducer should be mounted 25 to 75 cm (10 to 30 in) in front of the keel and a maximum of 10 cm (4 in) to the side of the centerline.
- On vessels with displacement hulls ❻, the transducer should be mounted approximately 1/3 aft of the waterline length of the vessel from the bow, and 150 to 300 mm (6 to 12 in) to the side of the centerline.
- The transducer should be mounted parallel to the bow-stern axis of your vessel.
- The transducer should not be mounted behind strakes, struts, fittings, water intake or discharge ports, or anything that creates air bubbles or causes the water to become turbulent. The transducer must be in clean (non-turbulent) water for optimal performance.
- The transducer should not be mounted in a location where it might be jarred when launching, hauling, or storing.
- On single-drive boats, the transducer must not be mounted in the path of the propeller. The transducer can cause cavitation that can degrade the performance of the boat and damage the propeller.
- On twin-drive boats, the transducer should be mounted between the drives, if possible.

1.5.3 Fairing Block Angle Cut

A fairing block positions your transducer parallel to the water line for increased sonar accuracy. You must measure the deadrise angle of your boat hull to determine if a fairing block is necessary to mount the transducer. If the deadrise angle of your mounting location exceeds 5°, you should use a fairing block to mount the transducer.

Deadrise Angle

Deadrise is the angle formed between a horizontal line and a boat hull at a single point. You can measure the deadrise angle with an angle finder, a protractor, or a digital level. You can also ask your boat manufacturer for the deadrise angle of the specific point on your boat hull.

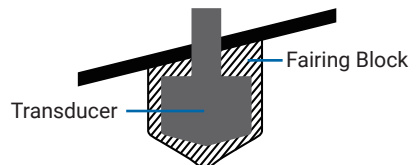
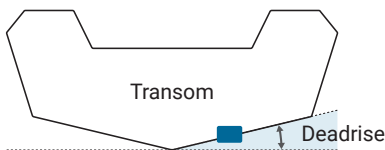

NOTE: A boat may have several deadrise angles depending on the shape of the hull. Measure the deadrise angle only at the location where you plan to install the transducer.

1.5.4 Cable Considerations

It may be necessary to drill 32 mm (1¼ in) holes for routing the power or network cables.

- When routing multiple cables through the same hole, you must route the network cable first because of the size of the network connector.
- You must apply marine sealant to the hole after the cables are in place to ensure a waterproof seal.

If the routing hole must be made in a visible location, decorative cable grommets can be purchased from Garmin or a Garmin dealer (optional).

- If needed, you can trim the grommet to enable you to route multiple cables through the same hole.
- The optional grommet does NOT provide a waterproof seal. You must apply marine sealant to the grommet after the cables are in place to ensure a waterproof seal.

When installing the cables, you should observe these considerations:

- Cutting the Garmin Marine Network cable is not recommended, but a field install kit can be purchased from Garmin or a Garmin dealer if cutting the network cable is necessary.
- To ensure safety, appropriate tie-wraps, fasteners, and sealant should be used to secure the cable along the route and through any bulkheads or the deck.
- You should not run cables near moving objects and high-heat sources, or through doorways and bilges.
- To avoid interference with other equipment, you should not run network and power cables next to or parallel to other cables, such as radio antenna lines or power cables. If this is not possible, the cables should be shielded with metal conduit or a form of EMI shielding.
- You should install the power cable as close to the battery source as possible.
 - If it is necessary to extend the cable, you must use the appropriate wire gauge.
 - Incorrectly extended runs of cable may cause the device to malfunction due to insufficient power transmission.

1.6 Cable and Connection Considerations

- The cables may have been packaged without the locking rings installed. If so, you should route the cables before you install the locking rings.
- After connecting a locking ring to a cable, make sure the ring is securely connected and the O-ring is in place so the connection remains secure.

1.6.1 Power/NMEA 0183 Cable

- The wiring harness connects the device to power, NMEA 0183 devices, and a lamp or a horn for visible or audible alerts.
- If it is necessary to extend the NMEA 0183 or alarm wires, you must use 22 AWG (.33 mm²) wire.

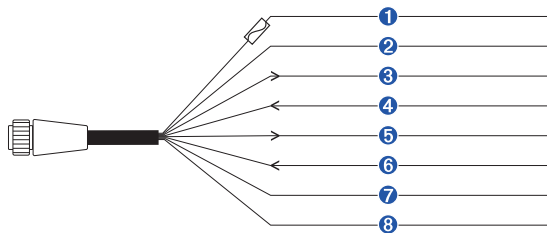

Item	Wire Color	Wire Function
1	Red	Power supply +
2	Black	Power supply - / Ground (power supply and NMEA 0183)
3	Blue	NMEA 0183 TXA
4	Brown	NMEA 0183 RXA
5	Gray	NMEA 0183 TXB
6	Violet	NMEA 0183 RXB
7	Orange	Accessory on
8	Yellow	Alarm low

1.6.2 Connecting the Wiring Harness to Power

⚠ WARNING

When connecting the power cable, do not remove the in-line fuse holder. To prevent the possibility of injury or product damage caused by fire or overheating, the appropriate fuse must be in place as indicated in the product specifications. In addition, connecting the power cable without the appropriate fuse in place voids the product warranty.

- 1 Route the wiring harness to the power source and to the device.
- 2 Connect the red wire to the positive (+) battery terminal, and connect the black wire to the negative (-) battery terminal.
- 3 If necessary, install the locking ring and O-ring on the end of the wiring harness.
- 4 Insert the cable into the POWER connector on the back of the device, pushing firmly.
- 5 Turn the locking ring clockwise to attach the cable to the device.

Additional Grounding Consideration

This consideration is applicable only to devices that have a grounding screw.

Not all models have a grounding screw.

This device should not need additional chassis grounding in most installation situations. If you experience interference, the grounding screw on the housing can be used to connect the device to the water ground of the boat to help avoid the interference.

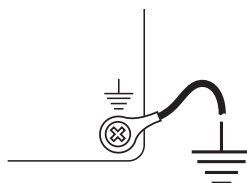

1.6.3 GPS Antenna Considerations

Before you can receive GPS information, you must install a compatible external GPS antenna and connect it to the device. When connecting the GPS antenna, you should observe these considerations.

- For a list of compatible antenna, visit support.garmin.com.
- Follow the instructions provided with the GPS antenna to install it on your boat.
- Connect the antenna to the GPS ANT port.

1.6.4 Connecting the Device to a Transducer

Devices that can receive depth information from a Garmin transducer have a port labeled 12-PIN XDRCR. Go to www.garmin.com or contact your local Garmin dealer to determine the appropriate type of transducer for your needs.

- 1 Follow the instructions provided with your transducer to install it on your boat correctly.
- 2 Route the transducer cable to the back of your device, away from sources of electrical interference.
- 3 Connect the transducer cable to the 12-PIN XDRCR port on your device.
- 4 Check that the device correctly displays the transducer model in the upper-left corner of the sonar display. If not, press **[MENU] > Installation > Transducer Models** to select the correct transducer model.

MENU

NOTICE

Driving the transducer with a wrong model would damage the transducer, so make sure the device has identified the transducer correctly. If you want to use a third-party transducer, contact your local Garmin dealer for the correct installation information.

1.6.5 GSD Sonar Considerations

NOTICE

The GSD Sonar port can connect to a GSD sonar module. Connecting other devices to the port will cause abnormal behavior and the device to turn off.

When connecting a GSD sonar module to this device, observe these considerations.

- A Garmin Marine Network cable must be used.
- Third-party CAT5 cable and RJ45 connectors must not be used.
- Additional Garmin Marine Network cables and connectors are available from your Garmin dealer.

1.6.6 NMEA 2000 Considerations

NOTICE

If you are connecting this device to an existing NMEA 2000 network, the NMEA 2000 network should already be connected to power. Do not connect the NMEA 2000 power cable to an existing NMEA 2000 network, because only one power source should be connected to a NMEA 2000 network.

If you are connecting this device to an existing NMEA 2000 network or engine network by another manufacturer, you should install a NMEA 2000 Power Isolator (010-11580-00) between the existing network and the Garmin devices.

- The port labeled NMEA 2000 is used to connect the device to an NMEA 2000 network.
- If you are installing a NMEA 2000 power cable, you must connect it to the boat ignition switch or through another in-line switch. NMEA 2000 devices will drain your battery if the NMEA 2000 power cable is connected to the battery directly.
- This device can connect to a NMEA 2000 network on your boat to share data from NMEA 2000 compatible devices such as a GPS antenna or a VHF radio. The included NMEA 2000 cables and connectors allow you to connect the device to your existing NMEA 2000 network. If you do not have an existing NMEA 2000 network you can create a basic one using cables from Garmin.
- If you are unfamiliar with NMEA 2000, you should read the “NMEA 2000 Network Fundamentals” chapter of the Technical Reference for NMEA 2000 Products. You can find this document using the “Manuals” link on the product page for your device at www.garmin.com.

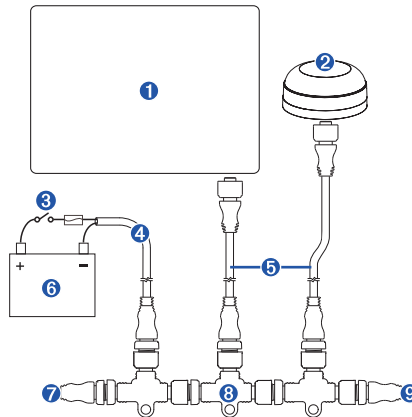

Item	Description
1	NMEA 2000 compatible Garmin device
2	GPS antenna
3	Ignition or in-line switch
4	NMEA 2000 power cable
5	NMEA 2000 drop cable
6	12 VDC power source
7	NMEA 2000 terminator or backbone cable
8	NMEA 2000 T-connector
9	NMEA 2000 terminator or backbone cable

1.6.7 NMEA 0183 Connection Considerations

- There is one internal NMEA 0183 input port (RX port) and one internal NMEA 0183 output port (TX port) on the included NMEA 0183 data cable. You can connect one NMEA 0183 device to the internal RX port to input data to this Garmin device, and you can connect up to three NMEA 0183 devices in parallel to the internal TX port to receive data output by this Garmin device.
- See the installation instructions for the NMEA 0183 device to identify the transmit (TX) and receive (RX) wires.

- The device provides one TX port and one RX port. Each internal port has 2 wires, labeled A and B according to the NMEA 0183 convention. The corresponding A and B wires of each internal port should be connected to the A (+) and B (-) wires of the NMEA 0183 device.
- You must use 28 AWG, shielded, twisted-pair wiring for extended runs of wire. Solder all connections and seal them with heat-shrink tubing.
- Do not connect the NMEA 0183 data wires from this device to power ground.
- The power cable from this device and the NMEA 0183 devices must be connected to a common power ground.
- For two-way communication with a NMEA 0183 device, the internal ports on the NMEA 0183 data cable are not linked. For example, if the input of the NMEA 0183 device is connected to TXA on the data cable, you can connect the output port of your NMEA 0183 device to the input port on the wiring harness.
- See NMEA 0183 Information, page 6 for a list of the approved NMEA 0183 sentences that are output by and input to this device.
- The internal NMEA 0183 ports and communication protocols are configured on the connected Garmin device. See the NMEA 0183 section of the chartplotter owner's manual for more information.

NMEA 0183 Device Connections

This diagram illustrates two-way connections for both sending and receiving data. You can also use this diagram for one-way communication. To receive information from a NMEA 0183 device, refer to items 1, 2, 3, 4, and 5 when connecting the Garmin device. To transmit information to a NMEA 0183 device, refer to items 1, 2, 3, 6, and 7 when connecting the Garmin device.

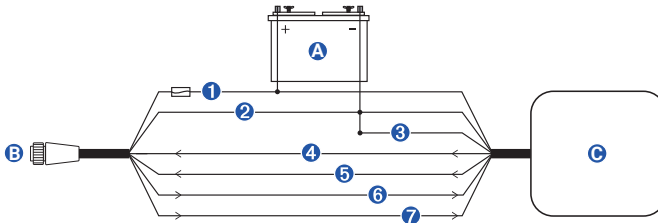

Item	Description
A	DC Power supply / battery
B	Power / NMEA 0183 cable
C	NMEA 0183 device

Item	Garmin Wire Color	Garmin Wire Function	NMEA 0183 Device Wire Function
1	Red	Power supply +	Power supply +
2	Black	Power supply - / ground	Power supply - / ground
3	Black	Data ground	Data ground
4	Brown	RXA (+)	TXA (+)
5	Violet	RXB (-)	TXB (-)
6	Blue	TXA (+)	RXA (+)
7	Gray	TXB (-)	RXB (-)

Single-Ended NMEA 0183 Device Connections

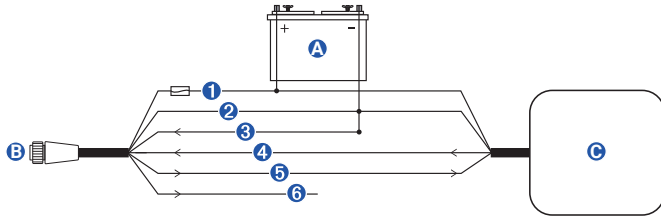

Item	Description
A	Power source
B	Power / NMEA 0183 cable
C	NMEA 0183 device

Item	Garmin Wire Color	Garmin Wire Function	NMEA 0183 Device Wire Function
1	Red	Power	Power
2	Black	Power ground	Power ground
3	Violet	RXB	N/A
4	Brown	RXA	TX
5	Blue	TXA	RX
6	Gray	TXB	N/A

- If the NMEA 0183 device has only one input (receive, RX) wire (no A, B, +, or -), you must leave the TXB wire unconnected.
- If the NMEA 0183 device has only one output (transmit, TX) wire (no A, B, +, or -), you must connect the RXB wire to ground.

NMEA 0183 Device Connected with a Single Receive Wire

In this example, the NMEA 0183 device is receiving data from the chartplotter.

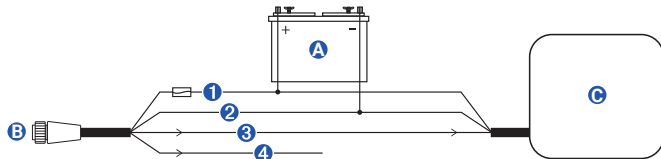

Item	Description
A	DC Power supply / battery
B	Power / NMEA 0183 cable
C	NMEA 0183 device

Item	Garmin Wire Color	Garmin Wire Function	NMEA 0183 Device Wire Function
1	Red	Power supply +	Power supply +
2	Black	Power supply - / ground	Power supply - / ground
3	Blue	TXA	RXA
4	Gray	TXB	N/A

NMEA 0183 Device Connected with a Single Transmit Wire

In this example, the NMEA 0183 device is sending data to the chartplotter.

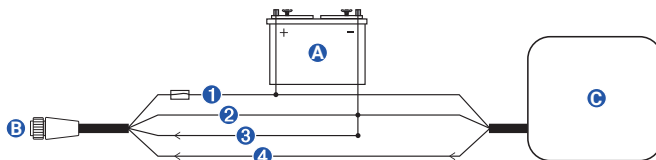

Item	Description
A	DC Power supply / battery
B	Power / NMEA 0183 cable
C	NMEA 0183 device

Item	Garmin Wire Color	Garmin Wire Function	NMEA 0183 Device Wire Function
1	Red	Power	Power
2	Black	Power ground	Power ground
3	Violet	RXB	N/A
4	Brown	RXA	TXA

NMEA 0183 and Power Cable Pinout

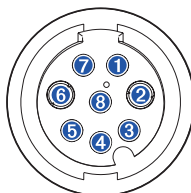

Pin	Wire Color	Wire Function
1	Gray	NMEA TXB
2	Black	Ground / Power supply -
3	Blue	NMEA TXA
4	Brown	NMEA RXA
5	Yellow	Alarm
6	Red	Power supply +
7	Violet	NMEA RXB
8	Orange	Accessory on

1.6.8 Lamp and Horn Connections

The device can be used with a lamp, a horn, or both, to sound or flash an alert when the chartplotter displays a message. This is optional, and the alarm wire is not necessary for the device to function normally. When connecting the device to a lamp or horn, observe these considerations.

- The alarm circuit switches to a low-voltage state when the alarm sounds.
- The maximum current is 1 A, and a relay is needed to limit the current from the chartplotter to 1 A.
- To manually toggle visual and audible alerts, you can install single-pole, single-throw switches.

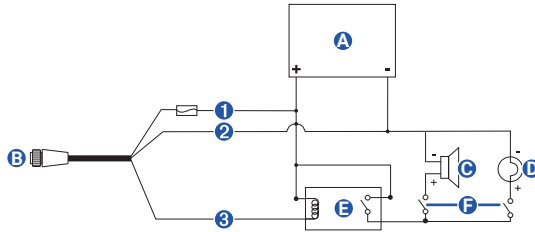

Item	Description
A	DC Power supply / battery
B	Power cable
C	Horn
D	Lamp
E	Relay (1 A coil current)
F	Toggle switches to enable and disable lamp or horn alerts

Item	Wire Color	Wire Function
1	Red	Power supply +
2	Black	Power supply - / Ground
3	Yellow	Alarm

1.7 Control Panel

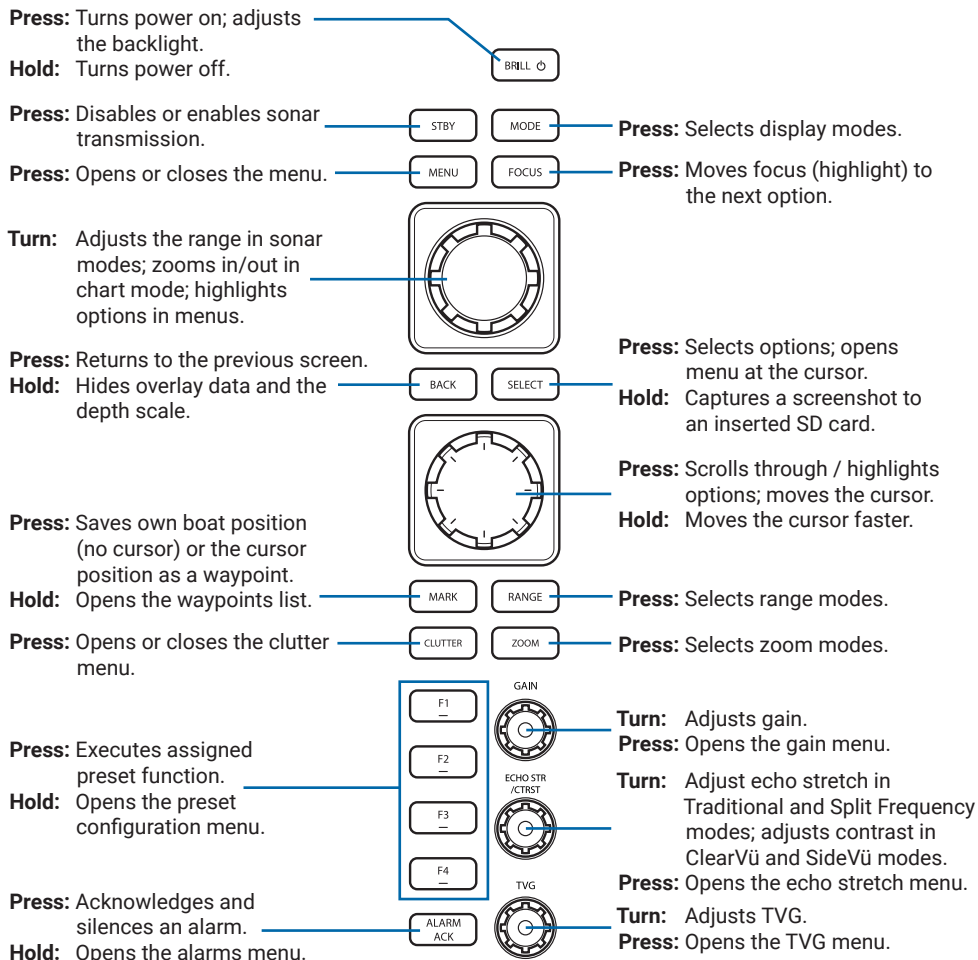

1.8 SD Card

NOTICE

To prevent corrosion and damage to the device, do not open the access flap when there are risks of water ingress.

You can use optional SD cards with the device for screen capturing, image viewing, and software installation. Map cards allow you to view high-resolution satellite imagery and aerial reference photos of ports, harbors, marinas, and other points of interest.

NOTE: This device supports memory cards with a storage of up to 32 GB, in FAT32 format.

- 1 Open the access flap below the control panel.
- 2 Insert an SD card to one of the two slots.

- 3 Press the card in until it clicks.
- 4 Close the access flap.

1.8.1 Capturing a Screenshot

- 1 Insert an SD card.

SELECT

- 2 Hold **[SELECT]** until a confirmation message appears. The captured screenshot is saved to the inserted SD card.

1.8.2 Updating the Software

You can either purchase a preloaded software SD card or download the software update to your own SD card.

NOTE: You must copy the software update to an SD card using a computer that is running Windows® software.

- 1 Go to the product page and download the software update.
- 2 Open the downloaded file, and follow the on-screen instructions to copy the software update to an SD card.

A Garmin folder containing the software update is created on the SD card.

- 3 Power on the device, and insert the SD card into one of the card slots.

NOTE: In order for the software update instructions to appear, the device must be fully booted before the card is inserted.

- 4 Follow the on-screen instructions.
- 5 Wait several minutes while the software update process completes.
- 6 When prompted, leave the SD card in place and restart the device manually.
- 7 Remove the SD card.

NOTE: If the memory card is removed before the device restarts fully, the software update is not complete.

1.9 Protective Cover

The protective cover protects the screen when the device is not in use. To remove the cover, hold the cover at the tab, and pull forward.

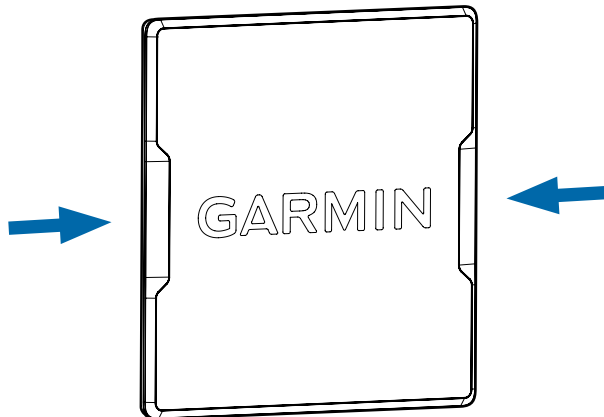

1.10 Garmin Support Center

Go to support.garmin.com for help and information, such as product manuals, frequently asked questions, videos, software updates, and customer support.

1.10.1 Registering Your Device

Help us better support you by completing our online registration today. Keep the original sales receipt, or a photocopy, in a safe place.

- 1 Insert an SD card into the card slot on the device.
- 2 Wait a few moments.
The device creates a file named `GarminDevice.xml` in the Garmin folder on the SD card.
- 3 Remove the SD card.
- 4 Insert the SD card into your computer.
- 5 On your computer, go to my.garmin.com.
- 6 Follow the on-screen instructions to download, install, and open the Garmin Express application.
- 7 Select **+** **Add a Device**.
- 8 While the application searches, select **Sign In** next to **Have marine charts or devices?** near the bottom of the screen.
- 9 Create or sign in to your Garmin account.
- 10 Follow the on-screen instructions to set up your vessel.
- 11 Select **+** **Add**.
The Garmin Express application searches the memory card for the device information.
- 12 Select **Add Device** to register the device.
When registration is complete, the Garmin Express application searches for additional charts and chart updates for your device.

When you add devices to the chartplotter network, repeat these steps to register the new devices.

CHAPTER 2 GETTING STARTED

2.1 Basic Operations

2.1.1 Powering On/Off



Press **[ϕ]** to turn on the device. The GARMIN logo appears, and the control panel lights up, and a sonar view of the water under your boat shows up on screen.



To turn the power off, hold **[ϕ]** until the GARMIN logo appears.

2.1.2 Stopping the Transmission of the Transducer

You can stop the transmission of the transducer if you are not going to use the sonar for an extended period of time. While stopped, the sonar view is paused.



- While scanning, press **[STBY]** to stop the transmission of connected transducers. Press **[STBY]** again to resume transmission. A straight line will separate the readings before and after the stop.



- You can also stop/resume the transmission by pressing **[MENU] > Sonar Setup > Transmit**.

2.1.3 Adjusting the Backlight



1 Press **[BRILL]** to bring up the **Backlight** bar.



2 Continue pressing **[BRILL]** to switch the backlight between 100%, 50%, and 0%, or rotate the main knob to adjust the backlight manually.

2.1.4 Switching Display Modes

The device features five display modes for different purposes.



Press **[MODE]** to open the **Display Mode** menu, use the main knob or the control pad to highlight a display mode, and press **[SELECT]** to switch to the highlighted mode.



Mode	Description
Traditional	Sonar view showing sonar readings from a transducer.
2-Split Frequency	Sonar view showing 2 split screens with customizable frequencies.
4-Split Frequency	Sonar view showing 4 split screens with customizable frequencies.
ClearVü	Sonar view with a much clearer image below your boat.
SideVü	Sonar view with a much clearer image to the sides of the boat.
Navigation Chart	Chart view with information for navigation.

When viewing the **2-Split Frequency** or **4-Split Frequency** modes, the device displays two or four split screens, each with its own frequency, range, zoom, and display settings.



Press **[FOCUS]** to sequentially highlight the split screens. When adjusting sonar settings, the last highlighted split screen will be adjusted.

2.2 Display Modes

2.2.1 Typical Views

The following views are typical examples of how each display mode looks like.

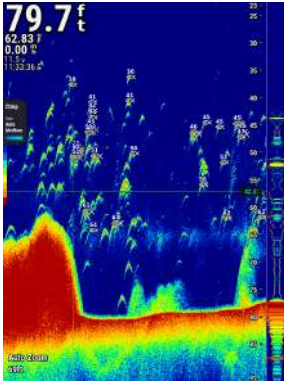

Traditional

Traditional mode shows a large image of the sonar readings from a transducer. The screen scrolls from right to left.

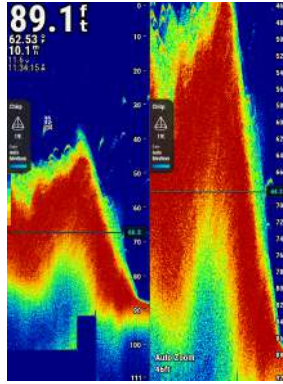

2-Split Frequency

2-Split Frequency mode shows two split screens with different sonar settings. The screens scroll from right to left.

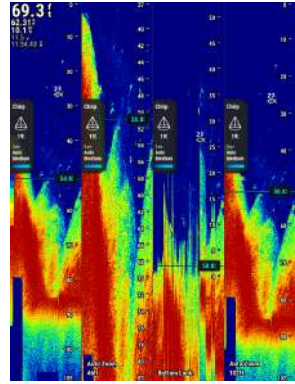

4-Split Frequency

4-Split Frequency mode shows four split screens with different sonar settings. The screens scroll from right to left.

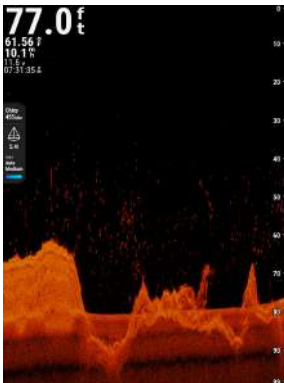

ClearVü

ClearVü mode shows a detailed picture of the fishing environment around the boat. The screen scrolls from right to left.

NOTE: Requires a compatible transducer.

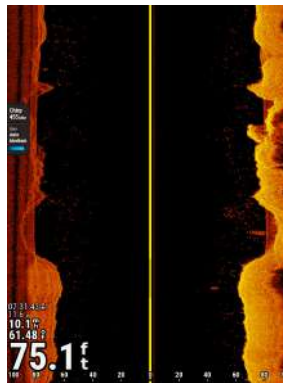

SideVü

SideVü mode shows a picture of what lies to the sides of the boat. The screen scrolls from top to bottom.

NOTE: Requires a compatible transducer.



Navigation Chart

Navigation Chart mode shows your vessel and navigation data on the map. The data includes tides & currents, service points, nav aids, grids, restricted areas, waypoints, boundaries, tracks, routes, and more.

2.2.2 Sonar Interface Overview

The following is an overview of the sonar interface, using the Traditional mode as an example.

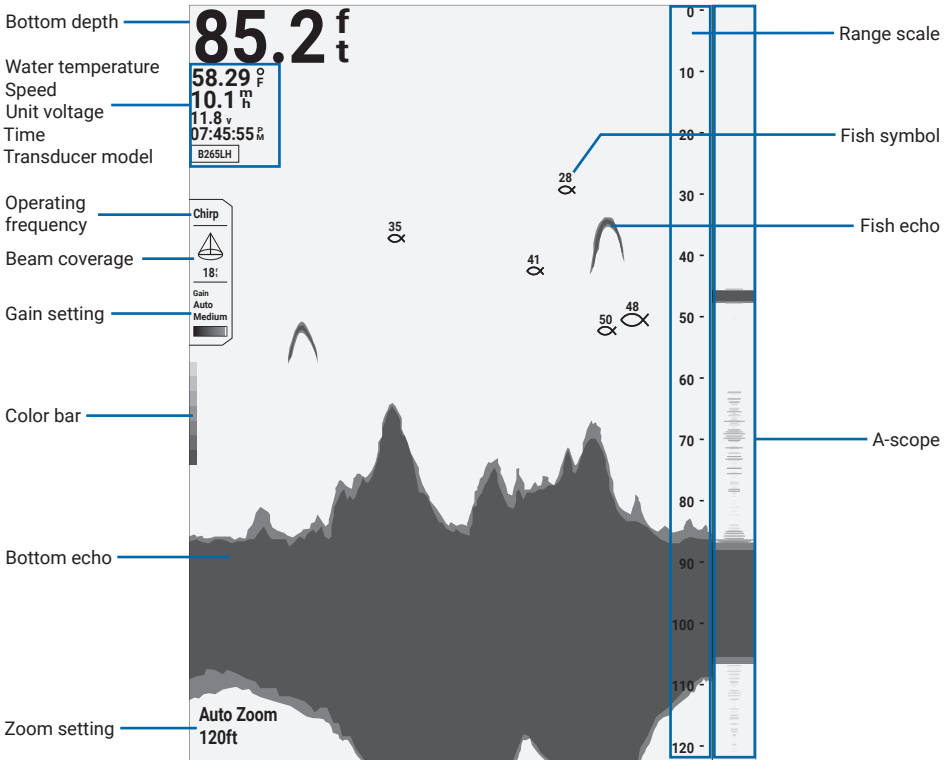

2.3 Adjusting the Sonar Display

2.3.1 Adjusting the Frequency of the Transducer

Different sonar frequencies reveal different levels of detail.

- Higher frequency pulses with narrower sonar beam coverage reveal more details, but cannot penetrate deep water.
- Lower frequency pulses with wider beam coverage penetrate deeper but reveal less detail.

Traditional sonar sends only one frequency at a time, resulting in restricted clarity and resolution. More advanced CHIRP sonars transmit a sweeping range of frequencies, providing better target separation and higher definition.

MENU

1 Press **[MENU]** > **Sonar Setup** > **Frequency**.

2 Use the main knob or the control pad to highlight a frequency.

SELECT

3 Press **[SELECT]** to adjust the highlighted frequency.

CHIRP Sonar

CHIRP (Compressed High-Intensity Radiated Pulse) is one of the most sophisticated sonar technologies available for the fishing and boating public. Instead of sending just one single frequency, CHIRP sonar sends a continuous sweep of frequencies ranging from low to high. Garmin CHIRP sonar technology then interprets each frequency individually upon its return.

This provides much more information, from which CHIRP sonar is able to construct a much clearer, higher resolution image with greater target separation and crisper fish arches. For example, 80–160 kHz sonar sweeps through the entire range from 80 kHz all the way up to 160 kHz, hitting every single frequency in between.



2.3.2 Adjusting the Range

The range controls the depth displayed on the sonar display. When range is set to **Auto** (the recommended setting), the depths will automatically track the bottom. Allowing the device to adjust the range automatically keeps the bottom within the lower or outer third of the sonar screen, and can be useful for tracking a bottom that has minimal or moderate terrain changes.

Range can also be manually set to a specific depth. Manually adjusting the range enables you to view a specified range, which can be useful for tracking a bottom that has large terrain changes, such as drop-offs or cliffs. For example, if searching for fish no deeper than 50 feet, the **Range** can be set to **50 ft**. The sonar display will then only show returns within 50 feet.

- Rotate the main knob to manually adjust the range.
- Press **[RANGE]** to switch between **Auto Range** and **Manual Range**.
- You can also adjust the range by pressing **[MENU] > Sonar Setup > Range**.

2.3.3 Adjusting the Zoom

The zoom controls the “field of vision” within the specified range.

- Press **[ZOOM]** and select an option.
- You can also select a zoom option by pressing **[MENU] > Sonar Setup > Zoom**.

While adjusting the zoom, a zoomed view appears on the left, with a zoom scope on the right edge of the screen.



No Zoom

Select **No Zoom** to view the full range from 0 to the set depth range (see 2.3.2).

Auto Zoom

Select **Auto Zoom** for a magnified view that is locked to the bottom. This is useful for determining the bottom contour.

ZOOM

- 1 Press **[ZOOM]** > **Auto Zoom**.
- 2 Press up/down to adjust the **Zoom** (width of view).

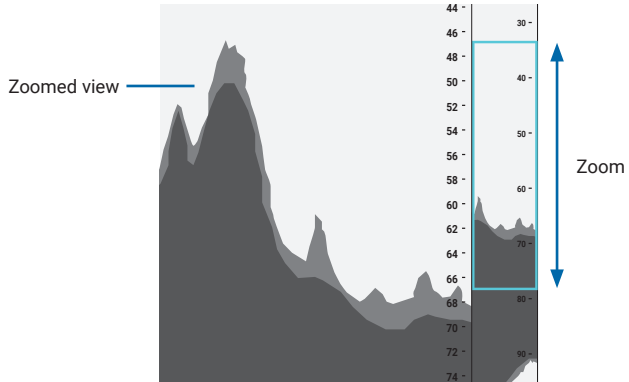

SELECT

- 3 Press **[SELECT]** to confirm the adjustment.

Set Zoom

Select **Set Zoom** to manually adjust the magnification within the specified range.

ZOOM

- 1 Press **[ZOOM]** > **Set Zoom**.
- 2 Press up/down to adjust the **Zoom** (width of view), and left/right to adjust the **Depth** (position of view).

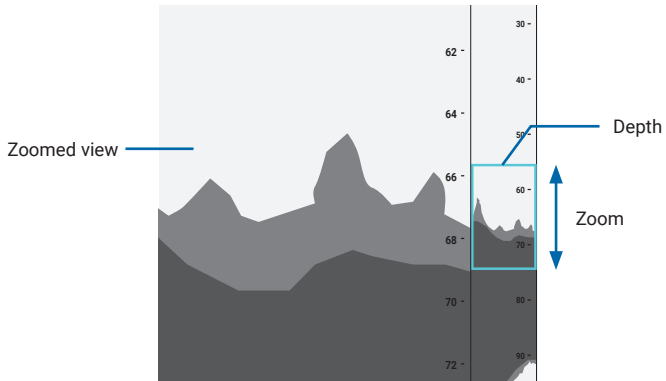

SELECT

- 3 Press **[SELECT]** to confirm the adjustment.

Bottom Lock

Select **Bottom Lock** to view a set range from the bottom up, with the bottom shown as a straight line. This is useful when distinguishing fish near the bottom.

NOTE: Not available in **SideVü** mode.

ZOOM

- 1 Press **[ZOOM]** > **Bottom Lock**.
- 2 Press up/down to adjust the **Top** (range above the bottom line), and left/right to adjust the **Bottom** (position of the bottom line).

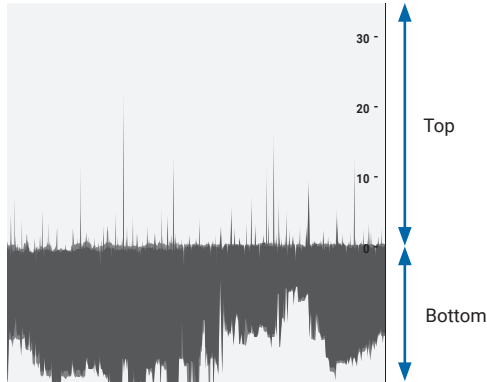

SELECT

- 3 Press **[SELECT]** to confirm the adjustment.

Shift Zoom

Select **Shift Zoom** to view the specified range with higher accuracy and detail with the unique sonar zoom technology from Garmin. In this mode the device only processes the sonar signals received from the selected depth range.

NOTE: Not available in **ClearVü** and **SideVü** modes.

ZOOM

- 1 Press **[ZOOM]** > **Shift Zoom**.
- 2 Press up/down to adjust the **Range** (width of view), and left/right to adjust the **Shift** (position of view).

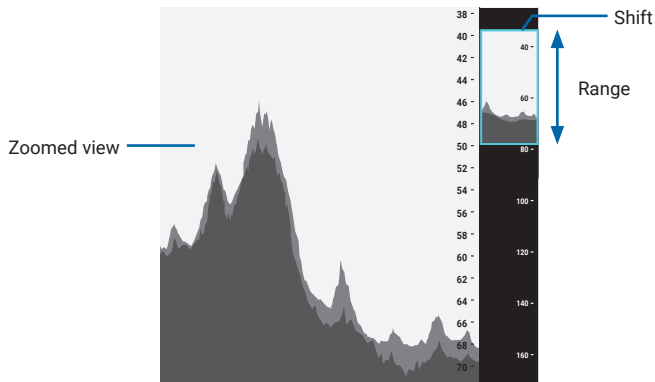

SELECT

- 3 Press **[SELECT]** to confirm the adjustment.

Split Zoom

Select **Split Zoom** to toggle a split screen on/off and opens the **Sonar Zoom** menu. You can continue to select a second zoom option for the split screen on the left, keeping the original zoom option on the right.

NOTE: Not available in **Split Frequency** modes.

2.3.4 Hiding Overlay Data and Depth Scale

The overlay data may obscure your view of the returns. To temporarily hide the overlay data and the depth scale, press and hold **[BACK]**.

BACK

All overlay data and the depth scales will be hidden while the button is held.

2.4 Optimizing the Sonar Display

2.4.1 Adjusting Gain

Gain controls the level of detail and noise shown on the sonar display. A higher gain setting amplifies the signals received and reveals more information, but also increases noise and clutter shown on the sonar display, and can make it more difficult to recognize actual returns. You can lower the gain to remove lower intensity returns and noise.



Low



Med

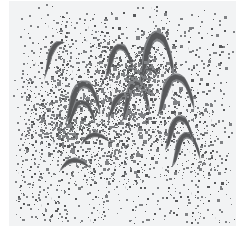

High

- Rotate the **[GAIN]** knob to adjust the gain and reduce noise on the screen.
- Press the **[GAIN]** knob to open the **Gain** menu. Rotate and press the knob to make a selection.

MENU

- You can also adjust gain by pressing **[MENU]** > **Sonar Setup** > **Gain** (see 3.2.1).

TIP: From a high level of gain, gradually reduce gain until the noise are barely showing on the sonar display.

2.4.2 Adjusting Echo Stretch

In **Traditional** and **Split Frequency** modes, you can increase echo stretch to expand the echoes on the screen to make it easier to see separate returns on the sonar display. The value ranges from -10 to 10. If the value is too high, the targets blend together. If the value is too low, the targets are small and more difficult to see.

- Rotate the **[ECHO STR]** knob to expand or contract the echoes.
- Press the **[ECHO STR]** knob to set the value to 0.

MENU

- You can also adjust contrast by pressing **[MENU]** > **Clutter** > **Echo Stretch** (see 3.3.6).

2.4.3 Adjusting Contrast

In **ClearVü** and **SideVü** modes, you can increase the contrast to highlight smaller fish targets or create a higher intensity display of a target. This causes a loss in the differentiation of the high intensity returns at the bottom. You can reduce the contrast if you want to reduce the intensity of the returns.



- Rotate the **[CTRST]** knob to adjust the gain and reduce noise on the screen.
- You can also adjust contrast by pressing **[MENU] > Sonar Setup > Contrast** (see 3.2.2).

2.4.4 Adjusting TVG

The intensity of sound reduces as sound propagates through water. As a result, nearby objects in shallow water produce louder echoes than faraway objects in deeper water.

The **TVG** (Time Varying Gain) compensates for this propagation loss of sound by using a lower gain level for nearby objects (immediately after the transmission of a ping), and then ramping up the gain level over time as the ping travels into deeper water, resulting in a more consistent level of gain throughout the depth of the water column. The **TVG** is also useful for reducing the level of noise near the surface.

- Rotate the **[TVG]** knob to select a level of **TVG**.

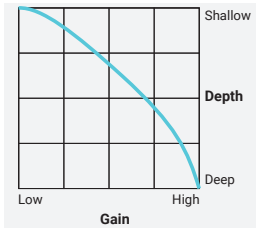

Low

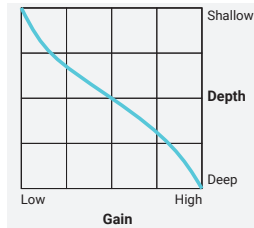

Medium

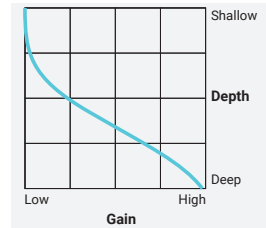

High



- You can also adjust **TVG** by pressing **[MENU] > Clutter > TVG**.

TIP: Avoid excessive **TVG**, as weak echoes may not be displayed.

2.5 Interfacing with the Sonar Display

2.5.1 Accessing the Menu



Press **[MENU]** to open/close the menu window for mode-specific menu and system settings (see [Chapter 3](#)).

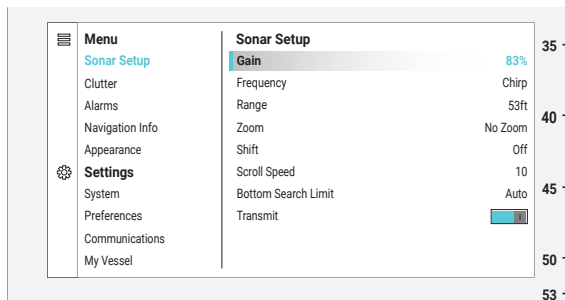

2.5.2 Selecting Split Screens

Split screens in the **2-Split Frequency** and **4-Split Frequency** modes can be adjusted individually.

FOCUS

- Press **[FOCUS]** to sequentially highlight split screens. The highlighted split screen is automatically selected.

BACK

- Press **[BACK]** to cancel the highlight. The selection is remembered until you switch to another mode.

2.5.3 Invoking the Cursor

Press left/right (up/down in **SideVü** mode) on the control pad to bring up the cursor and pause the sonar display.

The coordinates, distance, and bearing corresponding to the cursor are shown at the top-left of the sonar display.

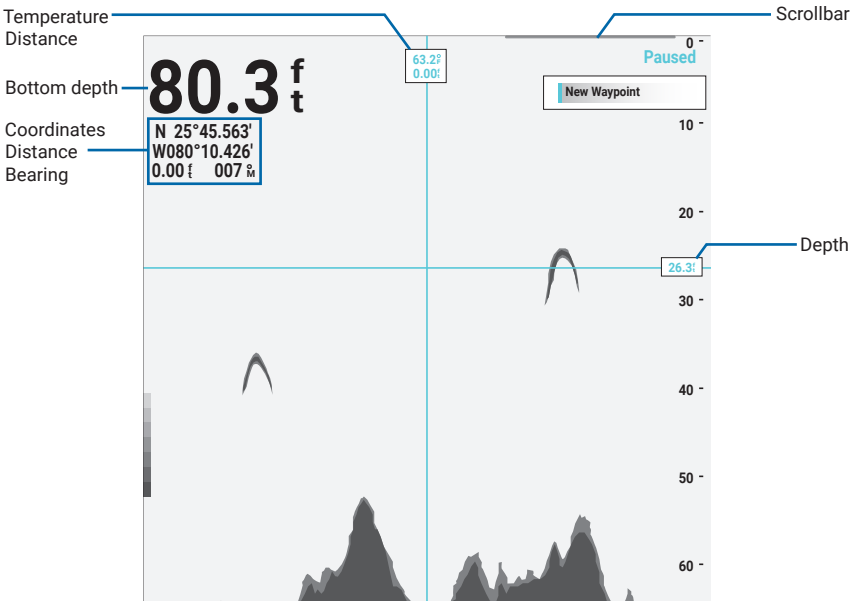

With the cursor showing:

- Press left (down in **SideVü** mode) to see older data, keep pressing to scroll the screen.
- Press right (up in **SideVü** mode) to see newer data, keep pressing to scroll the screen.
- Press up/down (left/right in **SideVü** mode) to go shallower/deeper.
- Rotate the main knob to zoom in/out on the cursor.
- Press **[SELECT]** or **[MARK]** to mark a waypoint at the cursor.
- Press **[BACK]** to return to live sonar data. A straight line will separate the readings before and after the pause.

MARK

BACK

2.5.4 Marking a Waypoint

MARK

MARK

SELECT

MARK

- To mark your boat position as a waypoint, press **[MARK]** without invoking the cursor.
- To mark previous positions and depths, move the cursor to a previous position, and either press **[MARK]** or press **[SELECT] > New Waypoint**.
- Hold **[MARK]** to open the **Waypoints** list:

Waypoints			
Symbol	Name	Distance	Bearing (Boat)
<input type="checkbox"/>	0001	0.78	324°
<input type="checkbox"/>	0002	0.62°	089°
<input type="checkbox"/>	0003	1.20°	125°
<input type="checkbox"/>	0004	3.28°	249°
<input type="checkbox"/>	0005	0.97°	206°
<input type="checkbox"/>	0006	0.83°	041°
<input type="checkbox"/>	0007	7.94°	102°
<input type="checkbox"/>	0008	8.06°	008°
<input type="checkbox"/>	0009	4.11°	338°
<input type="checkbox"/>	0010	0.35°	016°

Available 4988/5000 Sorted by Distance

Review
Sort/Filter >
Search
New Waypoint
Navigate To >
Back

SELECT

- Use the control pad to highlight a waypoint, and press **[SELECT]** or select **Review** to: move, navigate to, edit, change the symbol of, delete, or send an SOS distress call at the waypoint.
- Select **Sort/Filter** to sort the list by name, symbol, distance, or filter the list by symbol.
- Select **Search** to search for a waypoint by name.
- Select **New Waypoint** to add a new waypoint by entering the coordinates, selecting on the chart, using the current position, or entering the range and bearing.
- Select **Navigate To** to navigate to the highlighted waypoint either in a straight line or by marking a route on the chart.

2.5.5 Capturing a Screenshot

SELECT

From any screen, hold **[SELECT]** for 3 seconds, a screenshot (in PNG format) will be saved to your inserted SD card (see [1.8](#)).

2.5.6 Acknowledging and Silencing an Alarm

ALARM ACK

ALARM ACK

- When an alarm sounds, you can acknowledge and silence the alarm by pressing **[ALARM ACK]**.
- Hold **[ALARM ACK]** to open the **Alarms** menu (see [3.4](#)).

2.6 Navigation Chart

⚠ CAUTION

The navigation feature does not ensure obstacle and bottom clearance. Carefully compare the course to all visual sightings, and avoid any land, shallow water, or other obstacles that may be in your path.

The Navigation Chart mode allows you to view your vessel on preloaded or purchased charts and navigate to your destination.

2.6.1 Navigation Chart Interface

The following is an overview of the Navigation Chart interface. Rotate the main knob to zoom in and out.

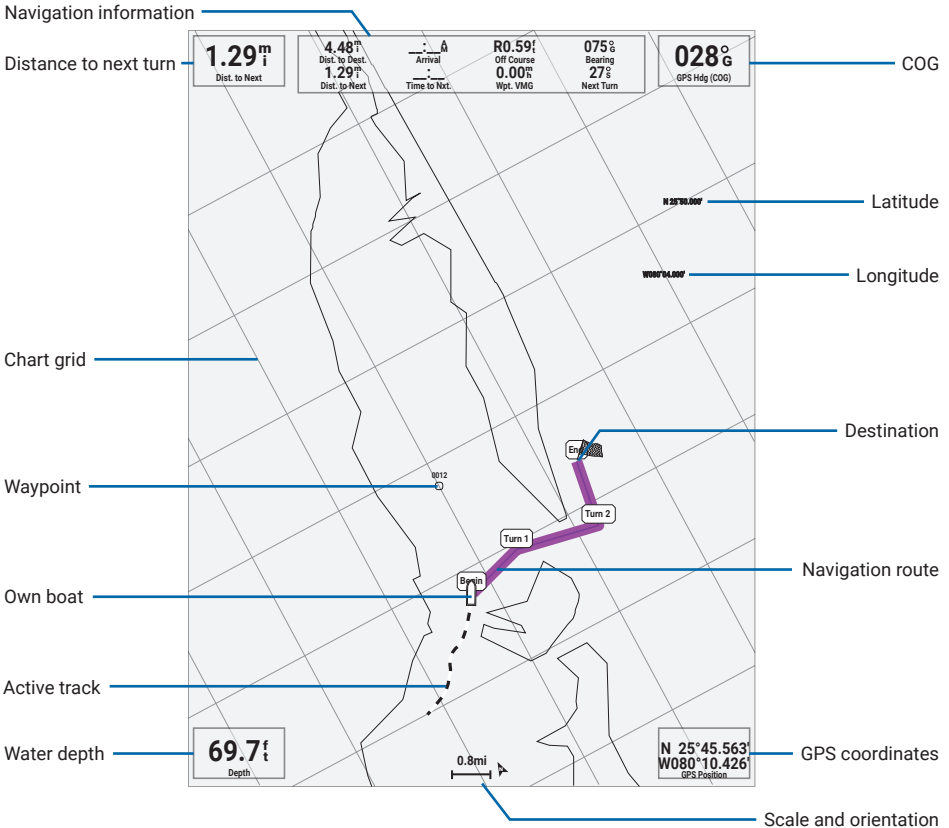

2.6.2 Navigating to a Point

You can select a point on the chart and set a course to the destination.

Navigating Directly to a Destination

1 Use the control pad to move the cursor to a point you would like to navigate to.

SELECT

2 Press **[SELECT]** > **Go To** to set a straight-line course to the destination.

Creating a Route to a Destination

- 1 Use the control pad to move the cursor to a point you would like to navigate to.
- 2 Press **[SELECT] > Route To.** to create a route with turns to the destination.
- 3 Use the control pad to move the cursor to the final turn, and press **[SELECT] > Add Turn.**
- 4 Working backward, continue adding turns until you've added the first turn.
- 5 Press **[SELECT] > Done** to set the course.

A magenta line appears. In the center of the magenta line is a thinner purple line that represents the corrected course from your current location to the destination. The corrected course is dynamic, and it moves with your boat when you are off course.

Follow the magenta line, steering to avoid land, shallow water, and other obstacles.

If you are off course, follow the purple line (corrected course) to go to your destination, or steer back to the magenta line (direct course).

Stopping Navigation

To cancel a route or stop navigation, press **[MENU] > Stop Navigation.**

2.6.3 Viewing Information

Tides

You can view information about a tide station for a specific date and time, including the tide height, and when the next high and low tides will occur. By default, the device shows tide information for the most recently viewed tide station, present date, and past hour.

- 1 Use the control pad to invoke the cursor.
- 2 Press **[SELECT] > Information > Tides.**

Currents

You can view information about a current station for a specific date and time, including the current speed and level of the current. By default, the device shows current information for the most recently viewed current station and for the present date and time.

- 1 Use the control pad to invoke the cursor.
- 2 Press **[SELECT] > Information > Currents.**

Celestial

You can view information about sunrise, sunset, moonrise, moonset, moon phase, and the approximate sky view location of the sun and moon. The center of the view represents the sky overhead, and the outermost rings represent the horizon. By default, the device shows celestial information for the present date and time.

- 1 Use the control pad to invoke the cursor.
- 2 Press **[SELECT] > Information > Celestial.**

Local Services

You can view local services information.

- 1 Use the control pad to invoke the cursor.
- 2 Press **[SELECT] > Information > Local Services.**

2.7 F1-F4 Shortcuts

The F1 to F4 shortcut buttons are assigned to various functions for quick accesses.

Mode	F1	F2	F3	F4
Traditional	A-Scope	Frequency	Scroll Speed	Fish Symbols
2-Split Frequency	Beam Coverage			
4-Split Frequency				
ClearVü	Depth Line			Surface Noise
SideVü				View Selection
Navigation Chart	Go To	Route To	Active Track	AIS

2.7.1 Using a Shortcut Function



1 Press a shortcut button to bring up the shortcut menu.



2 Press the shortcut button you wish to use.

NOTE: Some shortcut functions require the cursor on the screen.

2.7.2 Swapping an Assigned Function



1 Hold a shortcut button to bring up the **F1-F4 Presets** menu.

2 Use the main knob or the control pad to highlight the function you wish to swap out.



3 Press **[SELECT]**.

4 Use the main knob or the control pad to highlight the function you wish to swap in.



5 Press **[SELECT]**.

Available Functions for Sonar Display Modes

	Traditional	Split Frequency	ClearVü	SideVü
• A-Scope	○			
• Beam Coverage	○	○		
• Frequency	○	○	○	○
• Scroll Speed	○	○	○	○
• Fish Symbols	○	○		
• Depth Line	○	○	○	○
• Whiteline	○	○		
• Interference	○	○	○	○
• Smoothing	○	○		
• Surface Noise	○	○	○	
• Color Bar	○	○		
• Range Lines				○
• View Selection				○
• Quickdraw	○	○	○	○
• Sonar Recording	○	○	○	○

Available Functions for Navigation Chart Display Mode

- | | | |
|-----------------|-------------------|-------------------|
| • Go To | • Detail | • Spot Depths |
| • Route To | • Chart Size | • AIS |
| • Auto Guidance | • World Map | • Fishing Chart |
| • Active Track | • Inset Map | • Quickdraw |
| • Saved Tracks | • Depth Shading | • Sonar Recording |
| • Orientation | • Shallow Shading | |

CHAPTER 3 MENU AND SETTINGS

3.1 Accessing the Menu

The menu contains more advanced or less frequently used features and settings.



- From any screen, press **[MENU]** to open the menu.
- Use the main knob and the control pad to scroll through the menu.
- Press **[SELECT]** to make a selection.
- Press **[BACK]** to go back up a level.
- Press **[MENU]** again to close the menu.

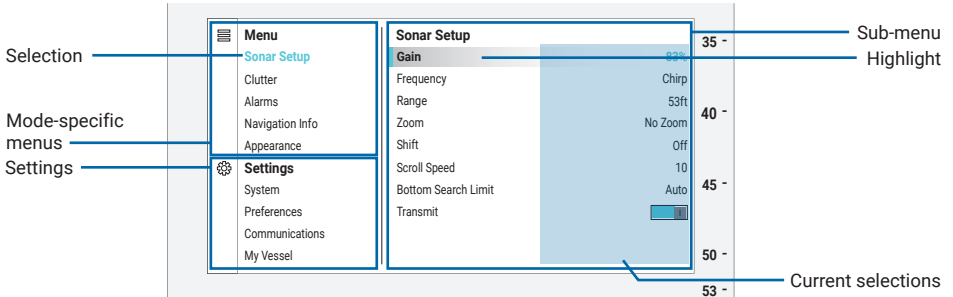

3.2 Sonar Setup



Press **[MENU]** > **Sonar Setup** in sonar modes to customize the settings of your sonar display.

NOTE: The menu is specific to **Traditional**, **Split Frequency**, **ClearVü**, and **SideVü** modes.

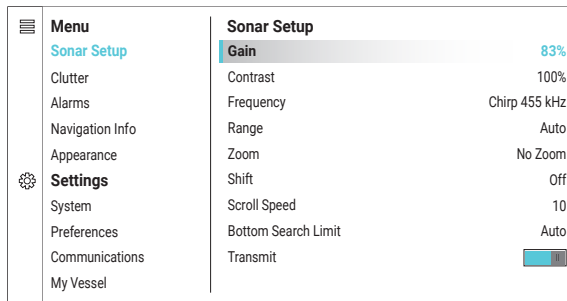

3.2.1 Adjusting Gain

You can control the level of detail and noise of the returns shown on the sonar display by adjusting gain (see [2.4.1](#) for more information).

Select **Gain** and make a selection:

- **Manual** allows you to adjust gain manually using the main knob or the control pad.
- **Auto Low** adjusts gain automatically to a low level.
- **Auto Med** adjusts gain automatically to a medium level.
- **Auto High** adjusts gain automatically to a high level.

3.2.2 Adjusting Contrast

You can control the level of contrast in **ClearVü** and **SideVü** modes to change the intensity of returns (see [2.4.3](#) for more information).

Select **Contrast** and make a selection:

- **Manual** allows you to adjust the contrast manually using the main knob or the control pad.
- **Default** sets the contrast level to the default value.

3.2.3 Adjusting Frequency

You can change the frequency of each sonar screen (see [2.3.1](#) for more information).

Select **Frequency** and make a selection from the available frequencies.

3.2.4 Adjusting Range

You can adjust the range of each sonar screen (see [2.3.2](#) for more information).

Select **Range** and make a selection:

- **Manual** allows you to adjust the range manually using the main knob or the control pad.
- **Auto** sets the range to automatically track the bottom.

3.2.5 Adjusting Zoom

You can adjust the zoom of each sonar screen (see [2.3.3](#) for more information).

Select **Zoom** and make a selection:

- **No Zoom** expands the view to show the full range.
- **Auto Zoom** tracks the bottom automatically.
- **Set Zoom** allows you to manually adjust the zoom.
- **Bottom Lock** locks the bottom to a flat line.
- **Shift Zoom** allows you to manually adjust the zoom with higher accuracy and detail.
- **Split Zoom** opens a split screen with a separate zoom.

3.2.6 Adjusting Shift

You can shift the depth range on which the sonar is focused. This allows you to view the focused depth at a higher resolution.

NOTE: Not available in **SideVü** mode.

NOTE: Bottom tracking may not work effectively, because the bottom may fall out of the focused area.

Select **Shift** and make a selection:

- **Manual** allows you to adjust the shift manually using the main knob or the control pad.
- **Off** turns off the shift.

3.2.7 Adjusting Scroll Speed

You can set the rate at which the sonar scan lines are generated and move across the screen. A higher scroll rate means more lines are generated, showing more details. A lower scroll rate generates fewer scan lines that stay on the screen longer. The speed selected for one sonar view applies to all the sonar views.

Select **Scroll Speed** and make a selection:

- **Manual** allows you to adjust the scroll speed manually using the main knob or the control pad.

TIP: Adjust to a slower speed to avoid gaps appearing in the seafloor.

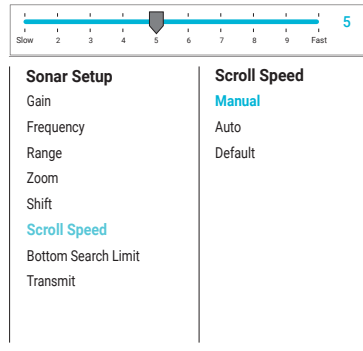

- **Auto** selects a scroll speed to match the boat speed, so targets in the water are drawn with the correct aspect ratio and appears less distorted. **Auto** is recommended for **ClearVü** and **SideVü** modes.
- **Default** sets the speed to the default scroll speed.

3.2.8 Adjusting Bottom Search Limit

You can set a maximum depth at which the auto range feature searches for the bottom. A lower limit acquires data about the bottom faster than a higher limit.

Select **Bottom Search Limit** and select either **Auto** or a limit ranging from 300 to 3000 ft.

3.3 Clutter

MENU

Press **[MENU]** > **Clutter** in sonar modes to improve the sonar view by reducing noise and interference, or adjusting the color and gain.

NOTE: The menu is specific to **Traditional**, **Split Frequency**, **ClearVü**, and **SideVü** modes.

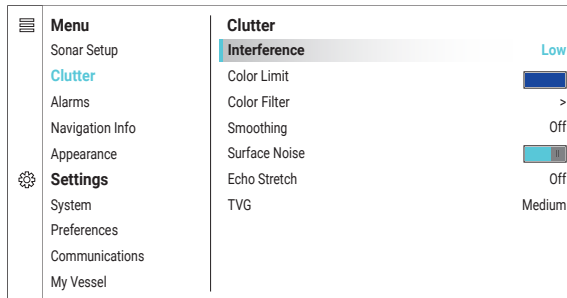

3.3.1 Reducing Interference

You can adjust the sensitivity to reduce the effects of interference from nearby sources of noise. Interference from other acoustic or electronic equipment operating nearby may appear on the display. Minor interference or noise can be stray signals that look like actual targets. Severe noise can completely fill the screen and make depth readings impossible. To counter interference, you have to first identify the type of interference. Although most noises can be eliminated with fairly simple techniques, some interference can only be reduced to a more acceptable level.

Select **Interference** and select a setting.

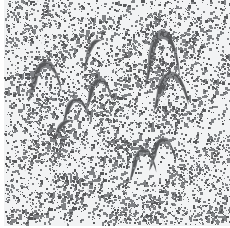

Low

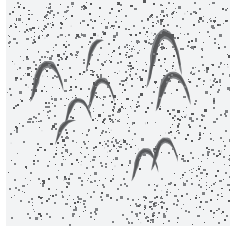

Medium

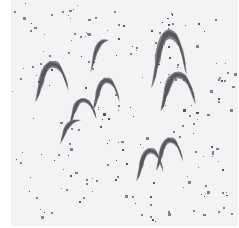

High

TIP: The lowest interference setting that achieves the desired improvement should be used.

3.3.2 Selecting a Color Limit

You can filter out weak clutter from the screen by selecting the threshold color and hiding part of the color palette.

NOTE: Not available in **ClearVü** and **SideVü** modes.

Select **Color Limit** and use the main knob or the control pad to select the threshold color.

3.3.3 Filtering Colors

You can customize the appearance of sonar returns by toggling individual colors on/off.

NOTE: Not available in **ClearVü** and **SideVü** modes.

Select **Color Filter** and select individual colors.

NOTE: The selection will not affect earlier sonar data.

3.3.4 Smoothing Noises

Smoothing removes noises that are part of normal sonar returns, and adjusts the appearance of returns such as the bottom.

The effect is more subtle than **Interference** (see 3.3.1) because of averaging. You can adjust interference and smoothing settings incrementally to remove undesirable noises from the display.

NOTE: Not available in **ClearVü** and **SideVü** modes.

Select **Smoothing** and select a setting.

3.3.5 Reducing Surface Noise

You can enable this setting to reduce clutter near the surface. Noise may appear near the surface when the sea is rough or when your boat passes over a wake. Wider beam widths can also result in more surface noise.

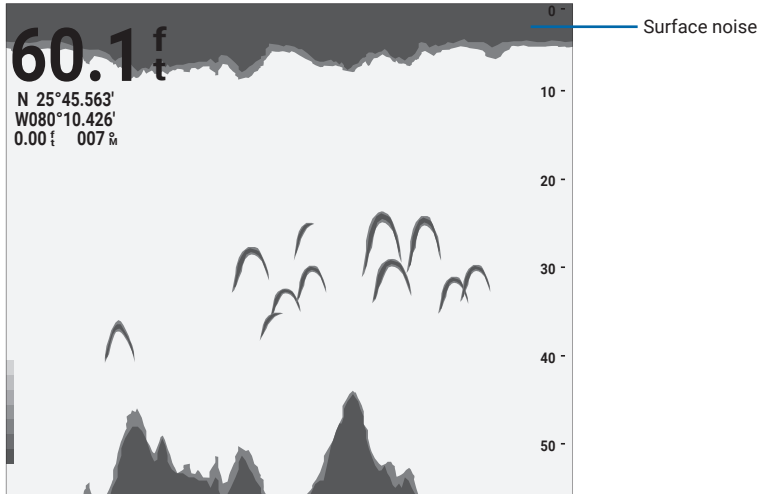

NOTE: Not available in **SideVü** mode.

Select **Surface Noise** to toggle the setting on/off.

3.3.6 Adjusting Echo Stretch

You can expand or contract sonar returns (see [2.4.2](#) for more information).

NOTE: Not available in **ClearVü** and **SideVü** modes.

Select **Echo Stretch** and make a selection:

- **Manual** allows you to adjust the stretch manually using the main knob or the control pad.
- **Off** turns off the shift.

3.3.7 Adjusting TVG

You can adjust TVG for a more consistent level of gain (see [2.4.4](#) for more information).

Select **TVG** and select a setting.

3.4 Alarms

MENU

Press **[MENU]** > **Alarms** to set up multiple alarms that will sound when the set conditions are met.

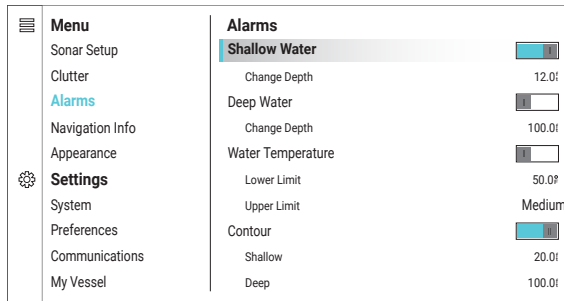

3.4.1 Setting a Shallow Water Alarm

The shallow water alarm will sound when the water is shallower than the set depth. Select **Shallow Water** to toggle the alarm on/off.

With **Shallow Water** toggled on, select **Change Depth** and use the main knob and the control pad to enter a depth.

3.4.2 Setting a Deep Water Alarm

The deep water alarm will sound when the water is deeper than the set depth. Select **Deep Water** to toggle the alarm on/off.

With **Deep Water Alarm** toggled on, select **Change Depth** and use the main knob and the control pad to enter a depth.

3.4.3 Setting Water Temperature Alarms

The water temperature alarm will sound when the transducer reports a temperature that is colder than the lower limit or hotter than the upper limit.

Select **Water Temperature** to toggle the alarm on/off.

With **Water Temperature** toggled on:

- Select **Lower Limit** and use the main knob and the control pad to enter a temperature.
- Select **Upper Limit** and use the main knob and the control pad to enter a temperature.

3.4.4 Setting Contour Alarms

The contour alarm will sound when a transducer detects a suspended target within the specified depths.

Select **Contour** to toggle the alarm on/off.

With **Contour** toggled on:

- Select **Shallow** and use the main knob and the control pad to enter the upper limit.
- Select **Deep** and use the main knob and the control pad to enter the lower limit.

3.4.5 Setting Fish Alarms

The fish alarm will sound when fish of different sizes are detected.

Select **Fish** and choose one of the settings:

- Select **Off** to turn the alarm off.
- $\infty + \infty + \infty$ sets the alarm off when fish of all sizes are detected.
- $\infty + \infty$ sets the alarm off when medium or large fish are detected.
- ∞ sets the alarm off only when large fish are detected.

3.4.6 Setting Collision Alarms

The collision alarm will sound if an AIS target is on a collision course with your boat.

Turning Collision Alarms On/Off

Select **Collision Alarm** > **Collision Alarm** and choose one of the settings:

- Select **On** to turn the alarm on.
- Select **Off** to turn the alarm off until you restart the device.
- Select **Always Off** to keep the alarm turned off until manually turned back on.







Adjusting Alarm Sensitivity

- Select **Collision Alarm** > **Range** to select a collision alarm range (from 500 feet to 10 miles). The collision alarm will sound when the target on a collision course comes within the selected range.
- Select **Collision Alarm** > **Time To** to select a collision alarm time (from 15 seconds to 24 minutes). The collision alarm will sound when the target on a collision course is expected to collide with your boat within the selected time.

3.4.7 Setting Up Boundaries

You can set up custom boundaries that alert you if your boat or other vessels enter or exit a boundary.

Select **Boundaries** to open a list of boundaries.

Boundaries				
Color	Name	Display	Alarm	Dist./Brg.
	AREA 001	Show	On	
	AREA 002	Hide	Off	
	CIRCLE 001	Hide	Off	
	CIRCLE 002	Hide	Off	
	LINE 001	Hide	Off	
	LINE 002	Show	On	✓
	LINE 003	Hide	Off	
Available Boundaries: 93/100				

New

Review

Show All

Hide All

<< Back

Adding a Boundary

- 1 Select **New** to add a new boundary.
 - Select **Line** to draw a linear boundary.
 - Select **Area** to draw a polygonal boundary area.
 - Select **Circle** to draw a circular boundary area.
- 2 Use the control pad to move the cursor to the first point, or the center of the circle.
- 3 Press **[SELECT]** > **Add Point / Set Center** to confirm the position.

SELECT

SELECT

- 4 Use the control pad to move the cursor to the next point, or the rim of the circle.
- 5 Press **[SELECT]** > **Add Point / Set Radius** to confirm the position.
- 6 For **Line** or **Area**, continue to add points until the boundary is complete.
- 7 Use the main knob, select **Done** to create the boundary.

Reviewing a Boundary

Use the control pad to highlight a boundary on the left, and select **Review**:

- Select **Display Options** to change how the boundary is displayed.
- Select **Edit Boundary** to edit or delete the boundary.
- Select **Alarm** and press **[SELECT]** to toggle the boundary alarm on/off.

SELECT

Showing/Hiding Boundaries

- Select **Show All** to display all boundaries in the **Navigation Chart** mode.
- Select **Hide All** to hide all boundaries from the **Navigation Chart** mode.

3.5 Sonar Appearance

MENU

Press **[MENU]** > **Appearance** in sonar modes to customize the appearance of your sonar display.

NOTE: The menu is specific to **Traditional**, **Split Frequency**, **ClearVü**, and **SideVü** modes.

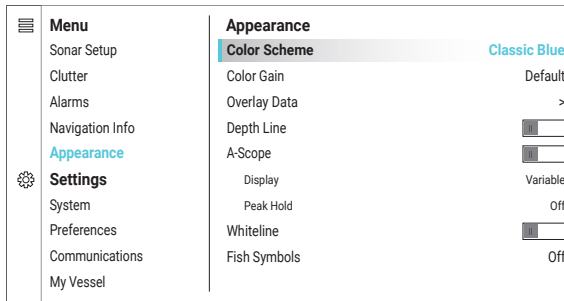

3.5.1 Changing the Colors

You can change how sonar returns are displayed on the sonar screen.

- Select **Color Scheme** and select one of the color schemes.
- Select **Color Gain** and use the main knob or the control pad to adjust the intensity of colors shown on the screen (only available in **Traditional** and **Split Frequency** modes).

TIP: Select a higher value to differentiate targets higher in the water column. Select a lower value when targets are near the bottom.

3.5.2 Selecting On-Screen Data

You can show or hide individual data on the screen.

- Select **Overlay Data** > **Depth** to show/hide the water depth.
- Select **Overlay Data** > **Water Temperature** to show/hide the water temperature.
- Select **Overlay Data** > **Unit Voltage** to show/hide the voltage.
- Select **Overlay Data** > **Speed** and select whether to hide the speed, show the speed over ground, show the speed over water, or automatically select which speed to show.
- Select **Overlay Data** > **Time of Day** to show/hide the time.
- Select **Overlay Data** > **Beam Coverage** to show/hide the beam coverage.

- Select **Overlay Data > Color Bar** to show/hide the color bar (only available in **Traditional** and **Split Frequency** modes).
- Select **Overlay Data > Transducer Model** to show/hide the transducer model.
- Select **Depth Line** to show/hide the depth line with a depth indicator, you can move the depth line with the control pad.
- Select **A-Scope** to show/hide the A-scope (only available in **Traditional** mode).

The A-scope is a vertical flasher along the right side of the screen that shows a live view of what is underneath the transducer. Echoes are shown in the A-scope as horizontal lines. You can use the A-scope to identify target returns that may be missed when the sonar data is quickly scrolling across the screen, such as when your boat is moving at high speeds.

With **A-Scope** toggled on:

- Select **Display > Full** to fix the amplitude at the full width of the A-scope.
- Select **Display > Variable** to vary the amplitude in relation to the echo strength.
 - With **Variable** selected, select **Peak Hold** to hide or keep the peak amplitude on the A-scope for 1 to 5 sec.
- Select **Whiteline** to show/hide the whiteline.

You can use whiteline to highlight the strongest signal from the bottom to help define the hardness or softness of the signal (only available in **Traditional** mode).
- Select **Fish Symbols** to show/hide fish symbols and depths as indicators for the positions and depths of fish schools (only available in **Traditional** and **Split Frequency** mode).
- Select **Range Lines** to show/hide the range lines extending from the range scale (only available in **SideVü** mode).

3.5.3 Selecting Views in SideVü Mode

You can view either or both sides in the **SideVü** mode.

NOTE: Only available in **SideVü** mode.

Select View Selection and make a selection:

- Select **Left Only** to expand the left side to fill the sonar screen.
- Select **Right Only** to expand the right side to fill the sonar screen.
- Select **Left + Right** to view both sides simultaneously.

3.6 Chart Setup

MENU

Press **[MENU] > Chart Setup** in Navigation Chart mode to customize the settings of your navigation chart.

NOTE: The menu is specific to **Navigation Chart** mode.

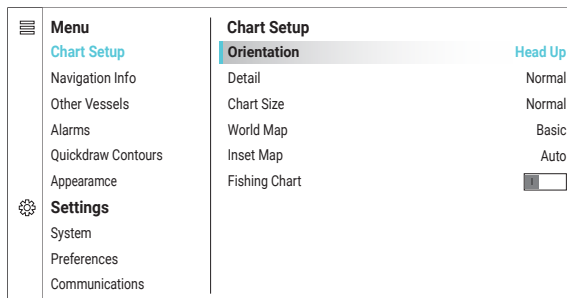

3.6.1 Selecting the Chart Orientation

The chart can be oriented in three different ways.

Select **Orientation** and select an option:

- Select **Head Up** to orient the chart so the heading always points straight up.
- Select **North Up** to orient the chart so north always points straight up.
- Select **Course Up** to orient the chart so the course (the direction your vessel is moving) always points straight up.

3.6.2 Personalizing the Chart

You can customize the chart based on your preference.

- Select **Detail** to adjust the level of detail of the chart (from **Least** to **Most**).
- Select **Chart Size** to adjust the size of the chart (from **Smallest** to **Largest**).
- Select **World Map** to switch between **Basic** view and **Full** view.
- Select **Inset Map** to show/hide an inset map.
- Select **Fishing Chart** to toggle the fishing chart on/off.

3.7 Navigation Info

MENU

Press **[MENU]** > **Navigation Info** to access navigation settings.

NOTE: The menu is specific to **Navigation Chart** mode.

Menu	Navigation Information
Chart Setup	Navigation to Position
Navigation Info	Waypoints
Other Vessels	Tracks >
Alarms	Routes
Quickdraw Contours	Boundaries
Appearance	Tides & Currents >
Settings	Services >
System	
Preferences	
Communications	

3.7.1 Navigating to Coordinates

You can navigate to a known position by entering its coordinates (in DDM format).

NOTE: Only available in **Navigation Chart** mode.

- 1 Select **Navigate To Position** and enter the coordinates.
- 2 Select **Done** or to begin navigating.
- 3 Press **[MENU]** > **Navigation Options** > **Stop Navigation** to stop navigating.

MENU

3.7.2 Managing Navigational Data

You can manage recorded waypoints, tracks, and routes. These can be stored in an inserted SD card.

- Select **Waypoints** to open the waypoints list (see 2.5.4).
- Select **Tracks** to view and edit track options (see 3.7.3).
- Select **Routes** to view and manage routes (see 2.6.2).
- Select **Boundaries** to view and manage boundaries (see 3.4.7).

3.7.3 Managing Tracks

A track is a recording of the path of your boat. The track being recorded is the active track. Select **Tracks** and choose one of the settings:

- Select **Active Track Options** to toggle on active tracking.
 - With the option toggled on:
 - Select **Record Mode** and select **Fill** to record until the memory is full, or **Wrap** to continuously record a track that replaces the oldest data, or **Off** to stop recording.
 - Select **Interval > Interval** and select **Distance** to record the track based on a distance interval, select **Time** to record the track based on a time interval, or select **Resolution** to record the track based on a variance from your course.
 - Select **Interval > Change** to enter a value.
 - Select **Track Color** to change the color of the track on the chart.
- Select **Save Active Track** to save the active track.
- Select **Clear Active Track** to clear the active track.
- Select **Follow Active Track** to retrace the active track.
- Select **Saved Tracks** to view, edit, follow, or delete saved tracks.

3.8 Other Vessels



Press **[MENU]** > **Other Vessels** to manage other vessels, including AIS and ATON targets, and change how they appear with these settings.

NOTE: The menu is specific to **Navigation Chart** mode.

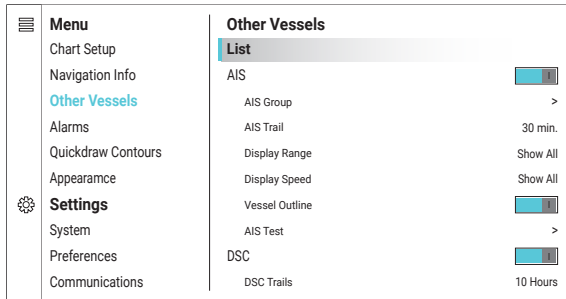

3.8.1 Managing Other Vessels

You can view/sort/filter a list of vessels and review individual vessels.



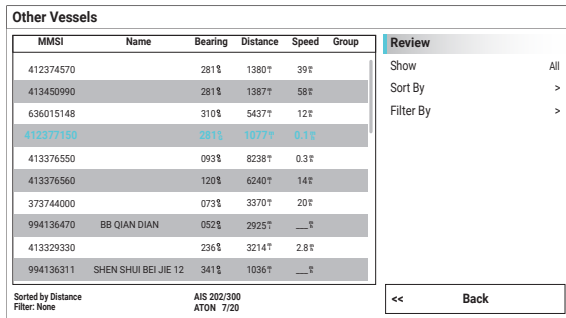



Select **List** to open the list of other vessels.



3.8.2 AIS

With the Automatic Identification System (AIS), the device identifies and tracks other vessels, and alerts you to area traffic. The device shows AIS information about vessels within range equipped with a transponder, and are actively transmitting AIS information.

Targets are indicated on the display with targeting symbols.

Symbol	Description
	AIS vessel. The vessel is reporting AIS information. The direction of the triangle indicates the direction the AIS vessel is moving.
	Selected target.
	Activated target. The target appears larger on the chart. A green line attached to the triangle indicates the heading of the target. The MMSI, speed, and direction of the vessel appear beneath the target if Details is turned on. If the AIS transmission from the vessel is lost, a message banner appears.
	Target is lost. A green X indicates that the AIS transmission from the vessel is lost, and the device displays a message asking whether the vessel should continue to be tracked. If you discontinue vessel tracking, the lost target symbol disappears from the chart.
	Dangerous target in range. The target flashes while an alarm sounds and a message appears. A red line attached to the triangle indicates the heading of the target. If Collision Alarm is off, the target flashes, but the audible alarm does not sound and the alarm message does not appear. If the AIS transmission from the vessel is lost, a message appears.
	Lost dangerous target. A red X indicates that the AIS transmission from the vessel is lost, and the device displays a message asking whether the vessel should continue to be tracked. If you discontinue vessel tracking, the lost dangerous target symbol disappears from the chart.
	The location of this symbol indicates the closest point of approach to a dangerous target, and the numbers near the symbol indicate the time to the closest point of approach to that target.

Select **AIS** to toggle AIS tracking on/off.

CAUTION

If turned off, all AIS functionality, including AIS vessel targeting and tracking, collision alarms from AIS vessels, and the display of information about AIS vessels, will be disabled.

With **AIS** toggled on:

- Select **AIS Group** to view and manage targets by 3 AIS groups.
- Select **Display Range** to select a range within which targets are displayed.
- Select **Display Speed** to set a speed above which targets are displayed.
- Select **Vessel Outline** to toggle vessel outlines on/off.
- Select **AIS Test** to select whether to receive or ignore Emergency Position Indicating Radio Beacon (EPIRB), Man Overboard (MOB), and Search and Rescue Transponder (SART) test alerts.

3.9 Quickdraw Contours

⚠ WARNING

The Garmin Quickdraw Contours mapping feature allows users to generate maps. Garmin makes no representations about the accuracy, reliability, completeness or timeliness of the maps generated by third parties. Any use or reliance on the maps generated by third parties is at your own risk.

MENU

Press **[MENU]** > **Quickdraw Contours** to create maps with contours and depth labels.

NOTE: The menu is specific to **Navigation Chart** mode.

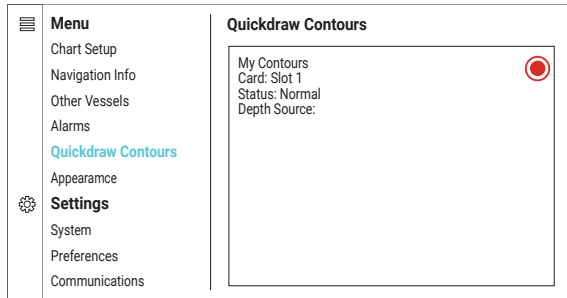

3.9.1 Mapping a Body of Water

1 Insert an SD card to one of the SD card slots.

2 Select **Start Recording**.

MENU

3 Press **[MENU]** > **Quickdraw Contours** > **Stop Recording** to stop recording.

When Garmin Quickdraw Contours records data, a colored circle surrounds the vessel icon. The circle represents the approximate area of the map that is scanned by each pass.

- A green circle indicates good depth and GPS position, and a speed under 16 km/h.
- A yellow circle indicates good depth and GPS position, and a speed between 16 and 32 km/h.
- A red circle indicates poor depth or GPS position, and a speed above 32 km/h.

The amount of saved data depends on the size of your memory card, your sonar source, and the speed of your boat as you record data. You can record longer when you use a single-beam sonar. It is estimated that you might be able to record about 1,500 hours of data onto a 2 GB memory card.

When you record data on a memory card, the new data is added to your existing Garmin Quickdraw Contours map, and is saved on the memory card. When you insert a new memory card, the existing data does not transfer onto the new card.

3.9.2 Adding a Label to a Quickdraw Contours Map

You can add labels to a Quickdraw Contours map to mark hazards or points of interest.

1 Use the control pad to move the cursor to a point on the navigation chart.

SELECT

2 Press **[SELECT]** > **Quickdraw Label**.

3 Enter text for the label, and select **Done**.

3.9.3 Garmin Quickdraw Contours Settings

- Select **Display** to toggle display options:
 - **All** displays all available contours maps.
 - **My Contours** displays your own contour maps.
 - **Community Contours** displays contours maps you have downloaded from the Garmin Quickdraw Community.
 - **Survey Coloring** displays the quality of the recording (the color of the colored circle when the area was surveyed, see 3.9.7).
- Select **Manage** to rename, copy, or delete recorded Quickdraw Contours in the SD card.
- Select **Settings** to adjust recording options:
 - **Recording Offset** sets the distance between the sonar depth and the contour recording depth. If the water level has changed since your last recording, adjust the setting so the recording depth is consistent.
 - **User Display Offset** sets the differences in contour depths and depth labels on your own contours maps to compensate for changes in the water level of a body of water, or for depth errors in recorded maps.
 - **Comm. Display Offset** sets the differences in contour depths and depth labels on the community contours maps to compensate for changes in the water level of a body of water, or for depth errors in recorded maps.
 - **Survey Coloring** displays the quality of the recording (the color of the colored circle when the area was surveyed, see 3.9.7).
 - **Depth Shading** sets the upper and lower limits of a depth range and a color for that depth range.

3.9.4 Garmin Quickdraw Community

The Garmin Quickdraw Community is a free, public, online community that enables you to share your Garmin Quickdraw Contours maps with others. You can also download maps other users have created.

To access the Garmin Quickdraw Community, sign in to your Garmin Connect™ account. You can then upload and download maps using a memory card.

Accessing the Garmin Quickdraw Community

You can access the Garmin Quickdraw Community from the Garmin Connect website.

- 1 Go to connect.garmin.com/start/quickdraw.
- 2 Agree to the end-user license agreement and select **Get Started**.
- 3 If you do not have a Garmin Connect account, create one.
- 4 Sign in to your Garmin Connect account.
- 5 Garmin Quickdraw widgets appear on your **Marine** Dashboard.
- 6 Click **QUICKDRAW** on the Quickdraw widget to open the full Quickdraw page.

Sharing Your Garmin Quickdraw Contours Maps

You can share your contours maps with others in the Garmin Quickdraw Community.

When you share a contours map, only the contours map is shared, your waypoints are not shared.

- 1 Insert the SD card containing your contours map file to your computer.
- 2 Access the Garmin Quickdraw Community.
- 3 Click **Share Your Contours**.

- 4 Browse to the /Garmin/Quickdraw folder and drop the file named **ContoursLog.svy** to the **Share Your Contours** widget, or click the square and select the contours file.



After the file is uploaded, delete the ContoursLog.svy file from your SD card to avoid issues with future uploads. Your data will not be lost.

Downloading Garmin Quickdraw Community Maps

You can download Garmin Quickdraw Contours maps that other users have created and shared with the Garmin Quickdraw Community.

- 1 Insert an SD card to your computer.
- 2 Access the Garmin Quickdraw Community.
- 3 Use the map and search features to locate an area to download.
- 4 The red dots or lines represent Garmin Quickdraw Contours maps that have been shared in that region.
- 5 Click **Select an Area to Download** and agree to the end-user license agreement.
- 6 Drag the corners of the box to select an area to download.
- 7 Click **Start Download**.
- 8 Save the .qcc file to your SD card.
TIP: If you cannot find the file, the file may have been saved to the Downloads folder by your browser.
- 9 Remove the SD card from your computer.
- 10 Insert the card to your device, the contours maps will be installed automatically. The installation may take a few minutes to complete.

3.10 Navigation Chart Appearance

MENU

Press **[MENU]** > **Appearance** in **Navigation Chart** mode to customize the appearance of your navigational chart.

NOTE: The menu is specific to **Navigation Chart** mode.

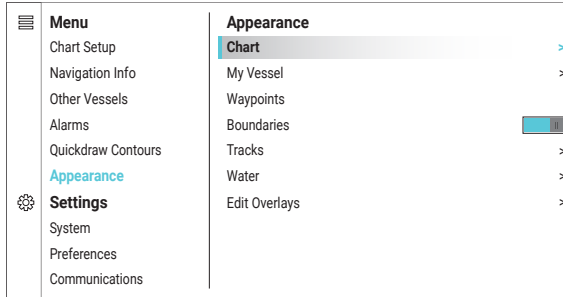

3.10.1 Customizing Chart Layers

- Select **Chart** to toggle chart layers on/off. Layers include **Tides & Currents, Land POIs, Service Points, Navaid, Grids,** and more.
- Select **My Vessel** to add/remove visual aids around your vessel. Visual aids include **Heading Line, Angle Markers, Compass Rose,** and more.
- Select **Waypoints** to manage waypoints.
- Select **Boundaries** to show/hide the boundaries (see 3.4.7).
- Select **Tracks** to show/hide saved tracks (see 3.7.3).
- Select **Water** to adjust how water depths are displayed on the chart.
- Select **Edit Overlays > Compass Tape** to show/hide the compass tape at the top or bottom of the screen.

3.10.2 Editing Data Panels

You can change the layout of the overlaying data panels.

Select **Edit Overlays > Data** and make a selection:

- **Top Bar** displays 6 data on the top of the screen.
- **Double Top Bar** displays 8 data in 2 rows on the top of the screen.
- **Corners** displays 4 data at the corners of the screen.
- **Double Corners** displays 8 data at the corners of the screen.
- **None** hides all data panels from the screen.

Replacing Data

To display a different data:

FOCUS

1 Press **[FOCUS]** and highlight the data box you wish to replace.

SELECT

2 Press **[SELECT]** and select the data you wish to display.

3.11 Settings

Settings below are for system-wide settings, device and software information, user preferences, and vessel information.

3.11.1 System Settings

MENU

Press [MENU] > **System** to adjust system-wide settings.

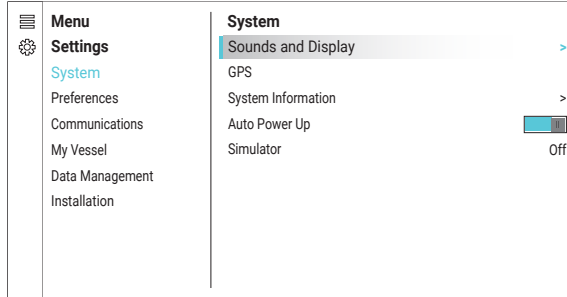

- Select **Sounds and Display** to adjust **Beeper**, **Backlight**, and **Color Mode**.
- Select **GPS** to view satellite information and adjust satellite settings.
- Select **System Information** to view device and software information.
- Toggle **Auto Power Up** to set the device to power on automatically or not when your vessel powers on.

Resetting to Default Settings

Select **System Information** > **Reset** > **Reset Default Settings** to restore the device to factory default settings.

3.11.2 Preferences

MENU

Press [MENU] > **Preferences** to adjust user preferences.

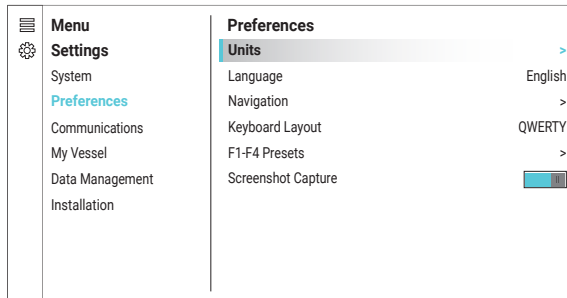

- Select **Units** to adjust the **System Units**, **North Reference**, **Variance**, **Position Format**, **Map Datum**, **Time Format**, and **Time Zone**.
- Select **Language** to change the system language.
- Select **Navigation** to adjust navigation settings.
- Select **Keyboard Layout** to choose between **ABCDE** and **QWERTY** keyboards.
- Select **F1-F4 Presets** to customize the shortcut buttons (see 2.7).
- Toggle **Screenshot Capture** to enable or disable the feature (see 2.5.5).

3.11.3 Communications Settings

MENU

Press **[MENU]** > **Communications** to adjust marine network settings.

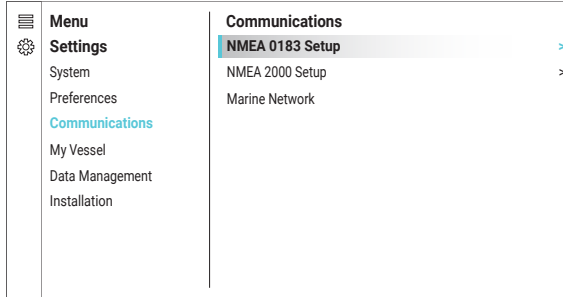

- Select **NMEA 0183 Setup** to change NMEA 0183 port and device settings.
- Select **NMEA 2000 Setup** to change NMEA 2000 device settings.
- Select **Marine Network** to rename devices connected to the network.

3.11.4 My Vessel Settings

MENU

Press **[MENU]** > **My Vessel** to adjust your vessel's settings, such as anchor height and fuel capacity.

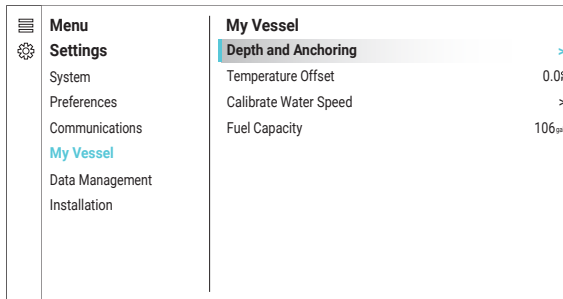

3.11.5 Data Management

MENU

Press **[MENU]** > **Data Management** to edit and retrieve stored data.

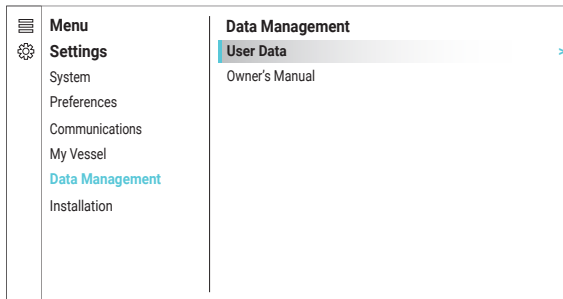

- Select **User Data** to transfer or delete user data, such as waypoints, routes, and tracks.
- Select **Owner's Manual** > **Open** to read the manual on the device.

CHAPTER 4 ECHO PATTERNS

There are other non-fish objects that reflect or block sonar beams. They form different patterns on the sonar screen. Learn to recognize these patterns to avoid misinterpreting them as fish schools.

4.1 Surface Noise

Surface noise appear near the top of the screen when the sea is rough or when your boat passes over a wake. The effect can be reduced in the **Clutter** menu (see 3.3.1).



4.2 Colliding Currents

When two ocean currents of different temperature and direction collide, they form eddies or gyres at the boundaries of the currents. They appear as long streaks of arcs on the sonar screen.

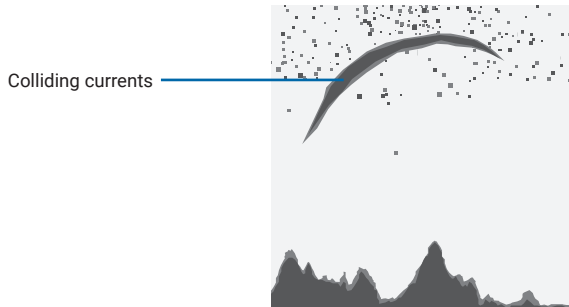

4.3 Plankton Layers

Layers of concentrated planktons of up to a few meters thick appear as a cloud of dots. They tend to rise up to the surface in the day and fall to deeper waters in the night.

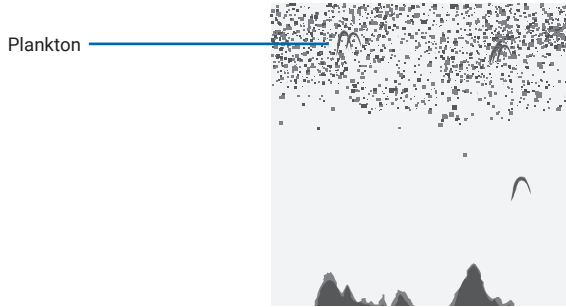

4.4 Air Bubbles

Air bubbles in the water can block sound waves, causing gaps in the water bottom.

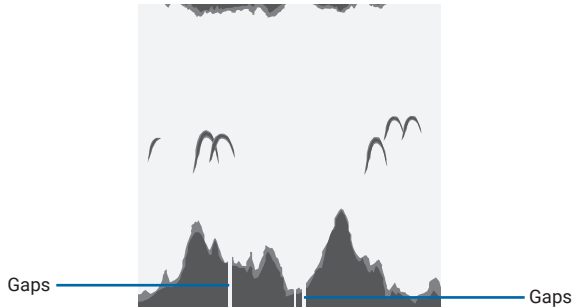

4.5 Side-Lobe Echoes

Some of the sonar beam escapes the sides, called side lobes. Echoes reflected from side lobes appear as shadows parallel to the water bottom.

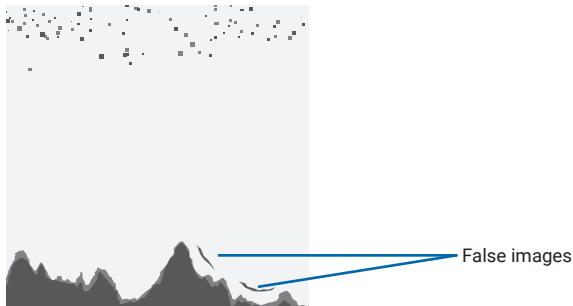

CHAPTER 5 APPENDICES

5.1 Error Message and Troubleshooting

If you encounter an error, refer to the table below for possible solutions.

Error Message	Solution
Software Update Required	Update the software.
Unit Voltage Alarm	The suggested input voltage is 10–36 VDC. Make sure there is no significant voltage drop along the power cable when the unit is in operation.
Lost Remote GPS Connection	Check the connections and the cables connecting external GPS antenna.
Satellite reception was lost.	Make sure the GPS antenna, whether internal or external, has a clear view of the sky.
Memory card is write protected.	Make sure the Lock switch is slid up to the unlock position.
Database Error	The device is unable to access the internal memory. Please contact Garmin Support.
Unsupported Transducer Connected	Check the connections to the transducer, and make sure a compatible transducer is connected and that settings are configured accordingly. If problems persist, contact Garmin Support.
Sonar module lost: (device)	Check the power and network connections on the external sonar module and the sonar display.

5.2 Hazardous Substance Table

产品中有害物质的名称及含量

部件名称	有害物质					
	铅	汞	镉	六价铬	多溴联苯	多溴二苯醚
印刷电路板组件	×	○	○	○	○	○
金属零件	×	○	○	○	○	○
电缆 电缆组件 连接器	×	○	○	○	○	○

本表格依据 SJ/T11364 的规定编制。
○：表示该有害物质在该部件所有均质材料中的含量均在 GB/T26572 规定的限量要求以下。
×：表示该有害物质至少在该部件的某一均质材料中的含量超出 GB/T26572 规定的限量要求。



5.3 Declaration of Conformity



Issued: 28/10/2019
Revised:

DECLARATION of CONFORMITY

Application of Council Directive: 2011/65/EU 2014/30/EU

Standard to which conformity is declared:

EN 301 489-1 v2.2.0 2017-03 - ElectroMagnetic Compatibility (EMC) standard for radio equipment and services; Part 1: Common technical requirements
EN 301 489-19 v2.1.1 2019-04 - ElectroMagnetic Compatibility (EMC) standard for radio equipment and services; Part 19: Specific conditions for Receive Only Mobile Earth Stations
EN 303 413 v1.1.1 (2017-06) Satellite Earth Stations and Systems (SES); Global Navigation Satellite System (GNSS) receivers; Radio equipment operating in the 1 164 MHz to 1 300 MHz and 1 559 MHz to 1 610 MHz frequency bands
IEC 60945:2002-08 - Maritime navigation and radiocommunication equipment and systems - General requirements - Methods of testing and required test results
EN 60950-1:2006+A11:2009+A1:2010+A12:2011+A2:2013 / IEC60950-1:2005 (2nd Ed) Am 1:2009 Am 2:2013 Information technology equipment – Safety – Part 1: General requirements
EN 62368-1:2014 - Audio, video, Information & Communication. Technology Equipment - Safety requirement

Manufactured by: GARMIN International & GARMIN Corporation
Manufacturer's Address: 1200 E. 151st Street
Olathe, Kansas 66062 U.S.A.
No.68 Zhangshu 2nd Rd., Xizhi Dist., New Taipei City 221, TAIWAN, R.O.C

Authorised Representative: GARMIN Würzburg GmbH
Beethovenstraße 1 a+b
97080 Würzburg, Germany

Type of Equipment: Portrait Radar/Sonar Display

Model Number(s): A03785 (CR 1522, CR 1523, CS 1522, CS 1523)

The undersigned does hereby declare that the equipment complies with the above Directives

Jamie Wiltshire
Quality Supervisor
Garmin (Europe) Ltd.

28/10/2019

5.4 Menu Tree

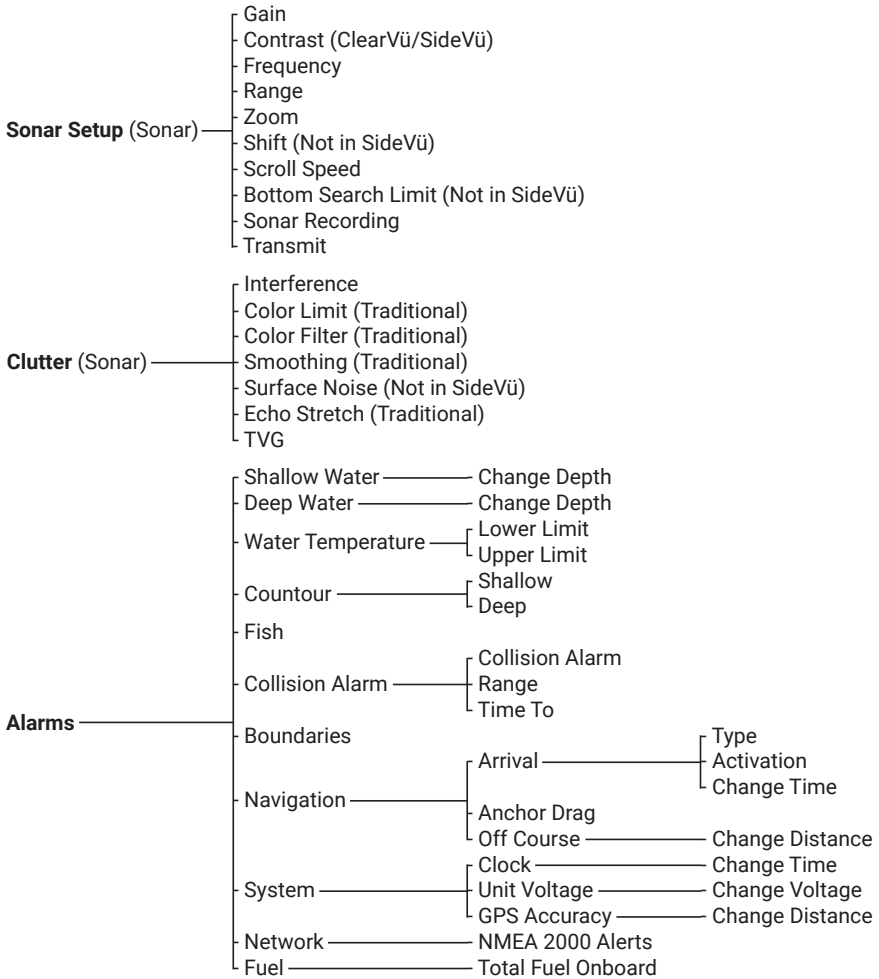

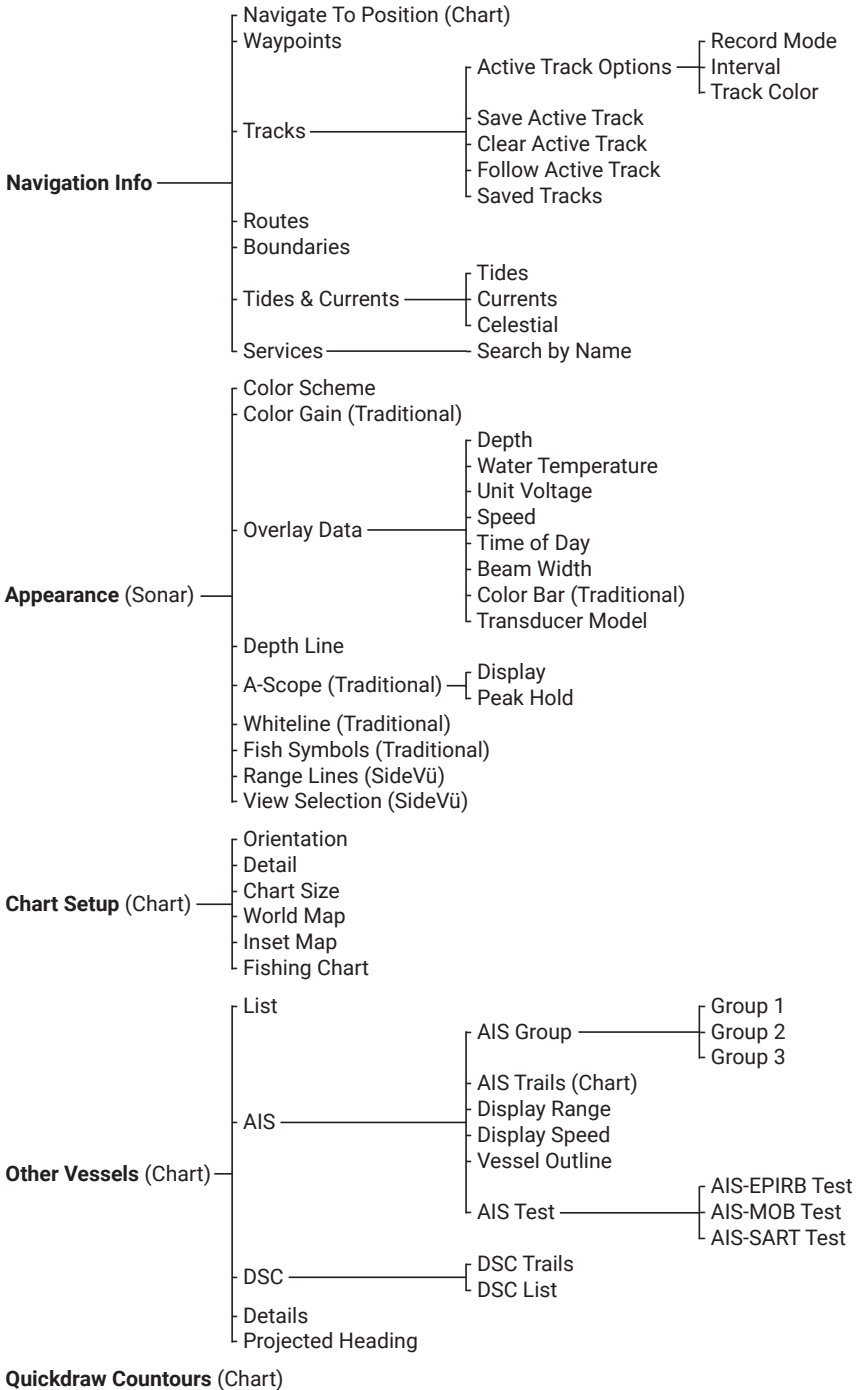

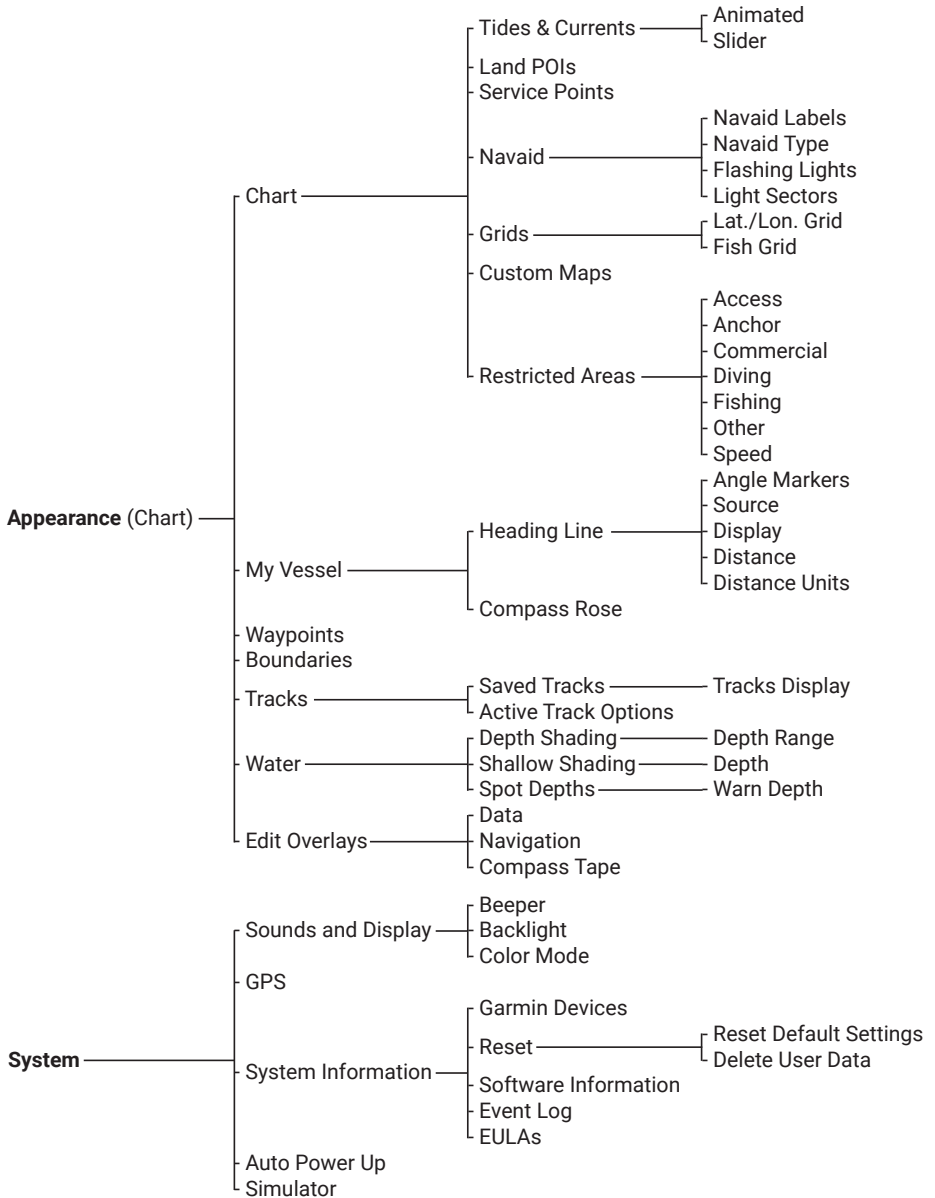

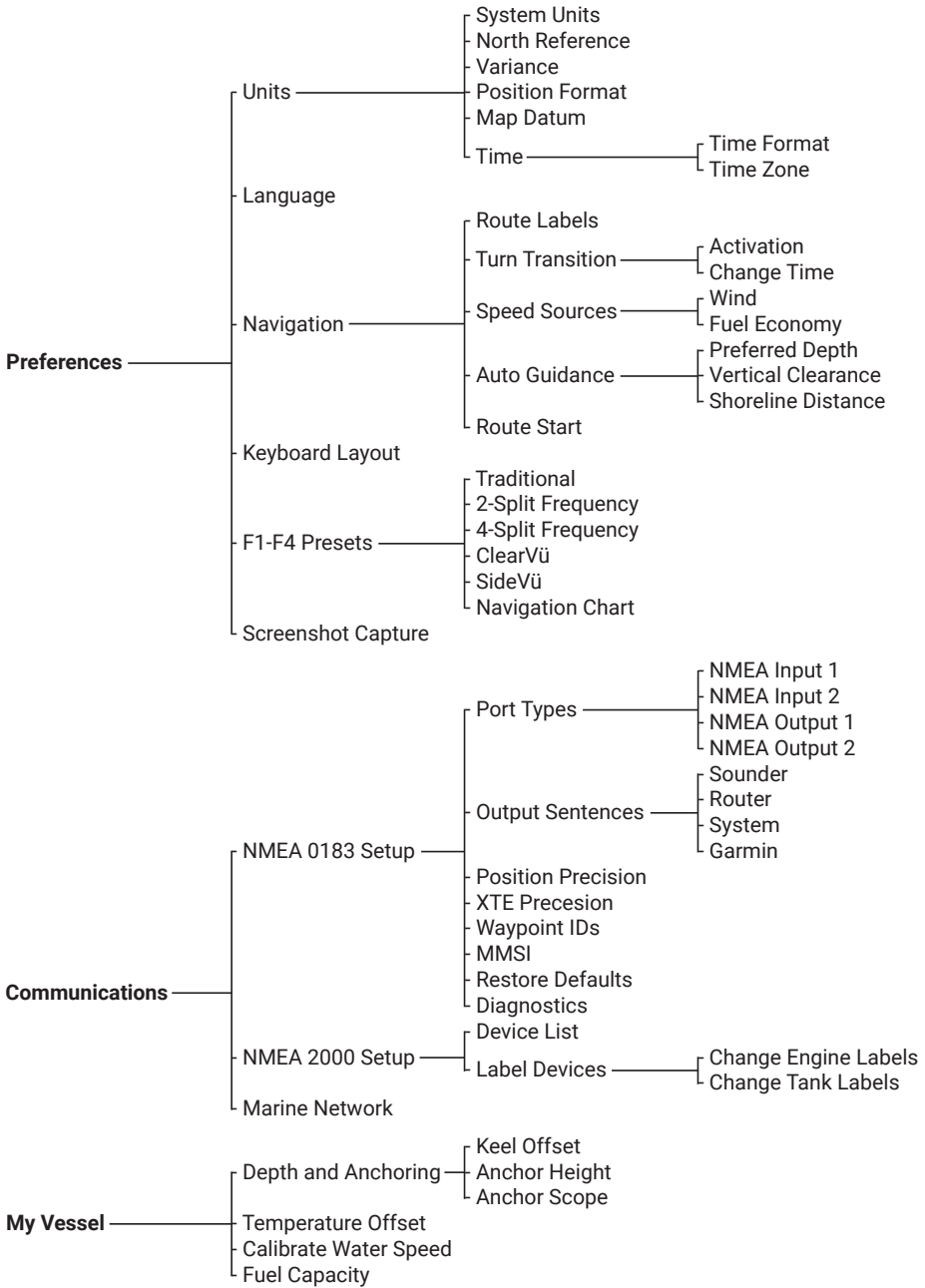

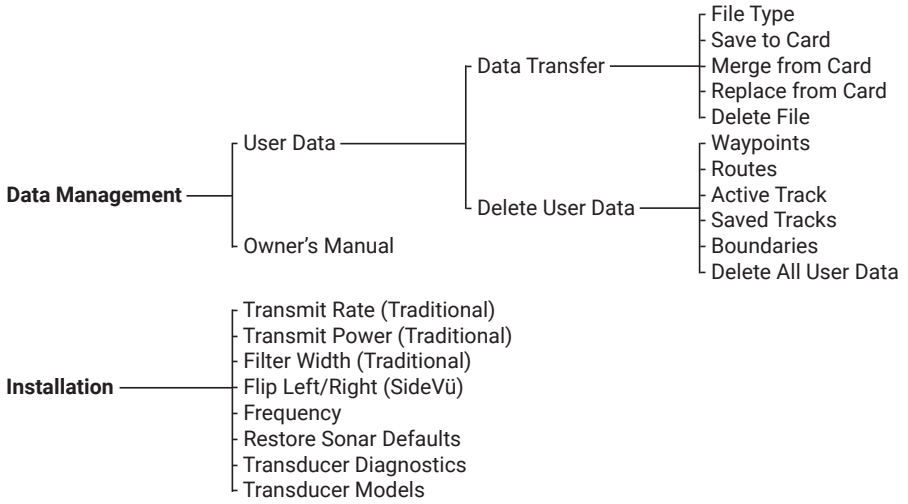

GARMIN®

Garmin International, Inc.

1200 East 151st Street, Olathe, Kansas 66062, USA

Garmin (Europe) Ltd.

Liberty House, Hounsdown Business Park, Southampton, Hampshire, SO40 9LR, UK

Garmin Corporation

No. 68, Zhangshu 2nd Road, Xizhi Dist., New Taipei City, 221, Taiwan



R-R-GRm-A03785

M/N: A03785

Manufactured in Taiwan