

图片

PICTURE



直流-3线/DC-3 wires NPN N.O.	CBT30-S10NA-D4YV1	* 29	CBT30-N15NA-D4YV1	* 29
直流-3线/DC-3 wires NPN N.C.	CBT30-S10NB-D4YV1	* 30	CBT30-N15NB-D4YV1	* 30
直流-3线/DC-3 wires PNP N.O.	CBT30-S10PA-D4YV1	* 31	CBT30-N15PA-D4YV1	* 31
直流-3线/DC-3 wires PNP N.C.	CBT30-S10PB-D4YV1	* 32	CBT30-N15PB-D4YV1	* 32
检测距离/ Rated sensing distance	10mm		15mm	
安装方式/ Mounting	埋入/shield		非埋入/non-shield	
工作电压/ Supply voltage	DC12...24V (10...30V DC) 允许波动10%以下/ripple(p-p):10% max.			
漏电流/ Leakage current	≤0.01mA			
设定距离/ Setting distance	0...7mm		0...10.5mm	
标准检出物体/ Standard target	接地金属板/ Grounded metal plate (30x30x1mm)		接地金属板/ Grounded metal plate (45x45x1mm)	
工作频率/ Frequency	50Hz			
消耗电流/ Consumption	≤10mA			
负载电流/ Load current	200mA			
电压降/ Voltage drop(V _r)	≤1.8V			
滞后/ Hysteresis	4...20%			
重复精度/ Repeatability	≤5%			
LED 显示/ Display	红色/ Red LED			
保护/ Protection Circuit	短路保护、反极性保护、过载保护/ Short circuit protection, reversed polarity protection and overload protection			
工作温度/ Operating temperature	-20...+60°C (未结露状态) / -20...+60°C (no condensation)			
抗冲击/ Anti-impact	500m/s ² (50G) X、Y、Z、方向各10次/ 500m/s ² (50G) X、Y、Z direction, each 10 times			
抗震动/ Anti-vibration	10...55Hz (振幅1.5mm) X、Y、Z、方向各2小时/ 10...55Hz (amplitude 1.5mm) X、Y、Z direction each 2 hours			
防护等级/ Protection	IP67			
连接方式/ Connection	M12插座式连接, 带LEDx4/M12 connector, LEDx4			
外壳材料/ Housing material	黄铜镀镍/ nickel-plated brass			
检测面材料/ Sensing face material	PBT			

尺寸图
Dimensional drawing

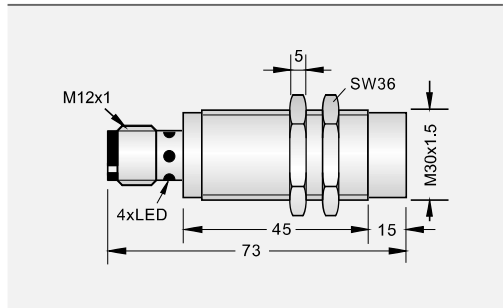
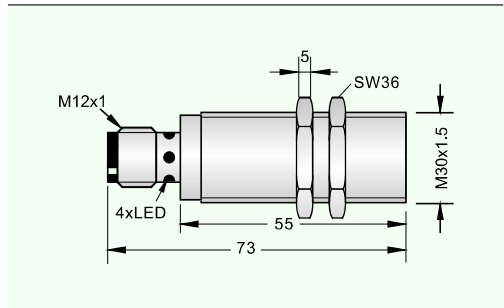

备注/Remark 1: *29, *30, *31, *32-NO of wiring diagram (refers to page 14...17) 2: Pigtail connection is also available