

图片

PICTURE



直流-3线/DC-3 wires NPN N.O.	IBT18-S05NA-D4YV1	* 29	IBT18-N08NA-D4YV1	* 29
直流-3线/DC-3 wires NPN N.C.	IBT18-S05NB-D4YV1	* 30	IBT18-N08NB-D4YV1	* 30
直流-3线/DC-3 wires PNP N.O.	IBT18-S05PA-D4YV1	* 31	IBT18-N08PA-D4YV1	* 31
直流-3线/DC-3 wires PNP N.C.	IBT18-S05PB-D4YV1	* 32	IBT18-N08PB-D4YV1	* 32
直流-2线/DC-2 wires N.O.	IBT18-S05LA-D4YV1	* 37	IBT18-N08LA-D4YV1	* 37
直流-2线/DC-2 wires N.C.	IBT18-S05LB-D4YV1	* 38	IBT18-N08LB-D4YV1	* 38
检测距离/ Rated sensing distance	5mm		8mm	
安装方式/Mounting	埋入/shield		非埋入/non-shield	
工作电压/Supply voltage	DC12...24V (10...30V DC) 允许波动10%以下/ripple(p-p):10% max.			
漏电流/Leakage current	3线式/3 wires : <0.01mA(2线式/2 wires: <0.8mA)			
设定距离/Setting distance	0...4.0mm		0...6.4mm	
标准检出物体/Sensing target	铁/Iron 18x18x1mm		铁/Iron 25x25x1mm	
工作频率/Frequency	600Hz		400Hz	
消耗电流/Consumption	≤15mA			
负载电流/Load current	200mA			
电压降/Voltage drop(V _p)	≤1.8V(2线式: 负载电流100mA < 5V)/≤1.8V(2 wires: Load current 100mA < 5V)			
滞后/Hysteresis	1...15%			
重复精度/Repeatability	≤5%			
LED 显示/Display	红色/Red LED			
保护/Protection Circuit	短路保护、反极性保护、过载保护/Short circuit protection, reversed polarity protection and overload protection			
工作温度/Operating temperature	-25...+70°C (未结露状态) / -25...+70°C(no condensation)			
抗冲击/Anti-impact	500m/s ² (50G) X、Y、Z、方向各10次/500m/s ² (50G) X、Y、Z direction, each 10 times			
抗震动/Anti-vibration	10...55Hz (振幅1.5mm) X、Y、Z、方向各2小时/10...55Hz(amplitude 1.5mm)X、Y、Z direction each 2 hours			
防护等级/Protection	IP67			
连接方式/Connection	M12插座式连接, 带LEDx4/M12 connector, LEDx4			
外壳材料/Housing material	黄铜镀镍/nickel-plated brass			
检测面材料/Sensing face material	PBT			

尺寸图
Dimensional drawing

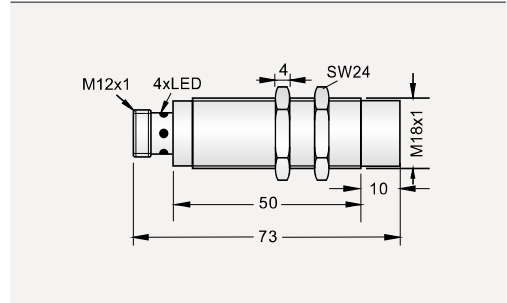
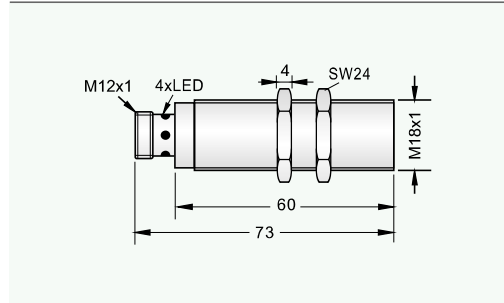

备注/Remark 注 1: *29, *30, *31, *32...表示接线图序号 详见14...17页。