

COOLMAY

EX3G-80 PLC/HMI All in one

Programming manual

(plc part: Difference comparing with Mitsubishi FX3G)

Content

1. Overview	1
1.1 PLC/HMI All in one Main Advantage:	1
1.2 Specification	3
1.3 Hardware description	4
1.3.1 EX3G-8043H structure description and dimension	4
1.3.2 EX3G-8050H structure description and dimension	5
1.3.3 EX3G-8070H (HD) structure description and dimension	6
1.3.4 EX3G-8100H structure description and dimension	7
1.3.6 Introduction of each interface and indicator	8
2. PLC	9
2.1 PLC Programming notice	9
2.2 Soft element table	10
2.3 Special relay number and content	12
2.4 Special register number and content	17
2.5 Function Instructions	21
2.5.1 List of basic logic instructions	21
2.6 Analog input	28
2.6.1 Analog input (temperature)	28
2.6.2 Analog input reading	30
2.6.3 Analog input sampling	31
2.6.4 Demo example	31
2.7 Analog output	32
2.8 PID instruction	33
2.8.1 Outline	34
2.8.2 PID instruction format and parameter description	34
2.8.3 Function and action description	34
2.8.4 Notice	37
2.8.5 Example	37
2.9. Application of high speed counter	38
2.9.1 Assignment table of built-in high speed counter	38
2.9.2 Related device	39
2.10. Application of high speed pulse	40
2.10.1 high speed pulse output	40
2.10.2 Circular interpolation	41
2.10.2.1 Normal Interpolation Function	41
2.10.2.2 Continuous interpolation function	43
2.10.3 Pulse width modulation (PWM)	45
2.10.4 Hand wheel pulse function	48
2.11 PLC Communication port instructions	50
2.11.1 MODBUS instruction interpretation and communication address	50
2.11.1.1 RD3A/WR3A command function and action description:	50
2.11.1.2 ADPRW command function and action description:	51
2.11.1.3 Word device Communication address number	51

2.11.1.4 Bit device Communication address number	52
2.11.1.5 ADPRW Command function parameter	52
2.11.2 Serial port 2: RS485(A B)	53
2.11.2.1 Mitsubishi programming port protocol	54
2.11.2.2 Free port protocol function and example	54
2.11.2.3 Modbus RTU Protocol	55
2.11.2.4 MODBUS RTU ADPRW command	58
2.11.2.5 Modbus ASCII Protocol	59
2.11.3 Serial port 3:RS485 (A1 B1)/RS232	61
2.11.3.1 Mitsubishi programming protocol	63
2.11.3.2 Mitsubishi BD Protocol	63
2.11.3.3 Free port protocol	64
2.11.3.4 Modbus RTU protocol RD3A/WR3A command	65
2.11.3.5 MODBUS RTU ADPRW Command	67
2.11.3.6 Modbus ASCII Function	69
2.11.4 CAN communication port	70
2.11.4.1 Free port protocol function	72
2.11.4.2 Modbus RTU Function RD3A/WR3A command	73
2.11.4.3 Modbus RTU Function ADPRW command	75
2.11.5 Network communication	76
2.11.5.1 Modbus TCP Function RD3A/WR3A Instructions	78
2.11.6 Network N:N communication	79
2.11.6.1 Related device content	79
2.11.6.2 Program setting and description	81
3. HMI	83
3.1 HMI program software user introduction	83
3.1.1 HMI Program software installation	83
3.1.2 Create new touch screen program	84
3.2 HMI Display download	85
3.2.1 Online download step (Type-C/Type-B download line download)	85
3.2.2 Configuration engineering upload	86
3.2.3 U disk download step	87
3.3 Other HMI usage	88
Appendix	89
Version Change Record	89

1. Overview

1.1 PLC/HMI All in one Main Advantage:

◆ Upper computer programming software compatible with Works 2/GX Developer8.86 (supports Ladder diagram and SFC language, does not support structured programming/labels).

HMI using coolmay Vcool software

◆ Powerful, compatible with FX3G/FX3U/FX3S PLC, high processing speed.

◆ Military level 32 bit CPU adopted, which is faster and more adapted to industrial environment of high electromagnetic interference.

◆ Special encryption, prevent illegal reading thoroughly. 8-bit encryption, 12345678 as password can thoroughly prevent reading of ladder logic program.

◆ Default With 1 HMI Downloading port, 2 PLC programming ports: RS232/MiniB USB port or Type-C port, and 1 USB port.

◆ Support Mitsubishi programming port protocol/Modbus protocol/Rs protocol/BD board protocol, PLC communication with each other and other devices is easily achieved.

◆ The PLC of EX3G-8100H all-in-one machine can be equipped with 1 RS485 or 2 RS485 (where 1 RS485 port is changed from the default RS232 port)/CAN/network port (cannot coexist with the touch screen network port)/WIFI (occupies the default RS232 port); HMI can be optionally equipped with 1 RS232 or RS485/Ethernet port (cannot coexist with PLC Ethernet port).

The PLC of EX3G-8070H/HD all-in-one machine can be equipped with 1 RS485 or 2 RS485 ports (where 1 RS485 port cannot coexist with the screen optional RS485 and the default RS232 port of the PLC)/CAN/network port (cannot coexist with the touch screen network port)/WIFI (occupies the default RS232 port); HMI can be equipped with 1 RS232 or RS485/Ethernet port (cannot coexist with PLC Ethernet port);

The PLC of EX3G-8043H/8050H all-in-one machine can be optionally equipped with 2 RS485; HMI can be optionally equipped with one RS232.

Used for external human-machine interface and frequency converter equipment.

◆ Supports Mitsubishi programming port protocol/MODBUS protocol/RS protocol/BD board protocol, easily achieving PLC interconnection and communication with external devices.

◆ High speed counting conventional single-phase 6-channel 60KHz or AB (Z) phase 2-channel 30KHz+AB phase 1-channel 5KHz;

High speed pulse conventional 8 channels: Y0-Y3 is 100KHz, Y4-Y7 is 10KHz;

The total output of high-speed counting and high-speed pulses cannot exceed 480KHz, with independent acceleration and deceleration.

◆ Supports multiple types of analog signals for individual or mixed input and output. The EX3G-8100H series can have up to 16 inputs and 8 outputs, the EX3G-8070H/HD series can have up to 12 inputs and 8 outputs, and the EX3G-8043H/8050H series can have up to 4 inputs and 2 outputs. Analog input/output 24

bit high-precision sampling, 16 bit data display. Analog inputs can be temperature/current/voltage inputs, while analog outputs can be voltage/current outputs.

The EX3G-8100H series switches up to 30 inputs and 30 outputs (up to 28 MRs), and the switch output can be selected as relay MR (maximum load 5A)/transistor MT (maximum load 500mA) or a mixed output MRT of relay and transistor;

The EX3G-8070H/HD series has a maximum of 24 inputs and 20 outputs (up to 16 MRs), and the switch output can be selected as relay MR (maximum load 5A)/transistor MT (maximum load 500mA) or a mixed output MRT of relay and transistor;









The EX3G-8043H/8050H series has a maximum switch quantity of 12 inputs and 12 outputs, and the switch quantity output can be selected as relay MR (maximum load 5A) or transistor MT (MOS transistor, maximum load 2A).

◆ Convenient wiring. All wiring terminals are equipped with 3.81 spacing plug-in terminals, making it convenient for customers to use.

◆ Flexible to use, more specifications and batches can be customized according to customer requirements.

The PLC program has a capacity of 32K steps, 32K power-off holding registers, supports interrupt interpolation PID self-tuning, and is extremely powerful.

1.2 Specification

Model	EX3G-8043H	EX3G-8050H	EX3G-8070H/HD	EX3G-8100H
Image				
				
Dimension	134*102*34mm	151*96*36mm	200*146*36mm	275*194*36mm
Cutout size	120*94mm	143*86mm	192*138mm	262*180mm
Power Consumption	4-6W	5-7W	6-7W	6-8W
HMI				
Features	16.77 million true color resistive touch screen; all sizes can be displayed vertically			
Display type	4.3"TFT	5"TFT	7.0"TFT	10.1"TFT
Display size	97*56mm	108*65mm	154*87mm	222*125mm
Resolution (pixels)	480*272	800*480	800*480/1024*600	1024*600
RAM	128MB		128MB/256MB	256MB
ROM	NAND Flash 128MB		NAND Flash 128MB/256MB	NAND Flash 256MB
CPU	Dual core 1GHZ			
Operation system	Based on Linux system			
COM Port	USB	Type-C (HMI download port); 1 USB 2.0 port		Type-B: 1 ↑ USB 2.0 port
	Other	Comes with 1 RS232	Comes with 1 RS232 or optional 1 RS485	
	Ethernet	/	Optional 1 network port (cannot coexist with PLC network port)	
programming software	Coolmay Vcool			
PLC				
I/O	Max 12DI/12DO		Max 24DI/20DO (16MR, Y20-Y23 are fixed as MT)	Max 30DI/30DO(26MR, Y20-Y23 are fixed as MT)
I/O levels	Input: Passive NPN, common terminal isolated; Output MT: low level NPN, COM connected to negative; Output MR: Normally open dry contact;			
DO type and load	Relay MR/MOS tube MOS tube: 2A/point, 4A/4-point COM, 5A/12-point COM; MR: 2A/point, 5A/12 points COM.		Relay MR/Transistor MT (Y0-Y3 are MOS tubes)/Mixed output MRT MOS tube: 2A/point, 4A/4 points COM; MT: 0.5A/point, 0.8A/4 points COM, 1.6A/8 points COM; MR: 2A/point, 4A/4 points COM, 5A/8 points COM, 5A/12 o' clock COM.	
High-speed counting input	Conventional 6 channels single phase 60KHz or 2 channels AB (Z) phase 30KHz + 1 channel AB phase 5KHz			
High-speed pulse output	Conventional 8 channels: Y0-Y3 is 100KHz, Y4-Y7 is 10KHz; high-speed counting + high-speed pulse total transmission cannot exceed 480KHz			
Analog	Input type	E_K_S_T_J_type negative temperature thermocouple /PT100/PT1000/NTC10K/NTC50K/NTC100K /0-10V/0-5V/0-20mA/4-20mA or mixed type, etc.		EKSTJ type thermocouple (can support negative temperature E_K_S_T_J)/PT100/PT1000 /NTC10K/NTC50K/NTC100K/0-10V/0-5V/-5V~-5V/-10V~-10V /0-20mA/4-20mA or mixed type and other special specifications
	Output type	0-10V/0-5V/0-20mA/4-20mA or mixed type optional		0-10V/ 0-5V/0-20mA/4-20mA/-5-5V/-10-10V (1 negative voltage accounts for 2 DA)
	Points	Max 4AI/2AO		Max 12AI/8AO[Up to 8 isolated analog inputs (AD5-AD12) can be selected]
Weigh	/		Optional installation of 2 or 4 weighing channels (cannot coexist with analog input)	
Communication Interface	Default	Comes with 1 TYPE-C programming port; default 1 RS232+1 RS485		Comes with 1 Mini USB programming port; Default: 1 RS232+1 RS485
	Optional	Optional 1 RS485 (Specially changed from the default RS232)		Optional 1 RS485 (specially modified from the default RS232)
	Other			Optional CAN port (2.0A/B) and network port (cannot coexist with the touch screen network port); Optional WIFI (will occupy the default RS232 port)
Programming software	Compatible with PLC programming software GX Developer8.86Q and GX Works2			
Common model specifications: EX3G-8043H/8050H-24MR/24MT(-4AD2DA-485P/232H) EX3G-8070H/HD-24MR/24MT(-12AD8DA-485P/232H); EX3G-8070H/HD-44MT/44MRT(-8AD6DA-485P/232H) EX3G-8100H-24MR/44MT/44MRT(-16AD8DA-485P/232H); EX3G-8100H-60MT/60MRT(-5AD2DA-485P/232H)				

485P/232P means 485/232 is optional on PLC; 485H/232H means 485/232 is optional on touch screen.
 *EX3G-8100H If the I/O is 30DI/ 30DO, the analog can be up to 5AI/2AO; if the I/O is 24 DI/ 20DO, the analog can be up to 16AI/ 8AO
 For detailed information, please refer to: "Coolmay EX3G-80 series all-in-one computer programming manual" "EX3G-80 series all-in-one computer user manual"
 "Coolmay TK80 series touch screen user manual"

1.3 Hardware description

1.3.1 EX3G-8043H structure description and dimension

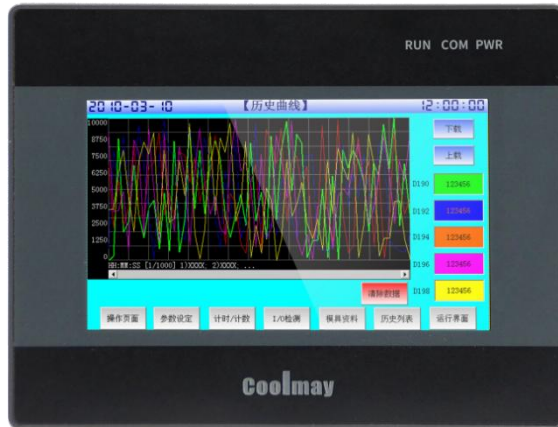

EX3G-8043H



- * Dimension(mm): 134*102*34
- * Cutout size(mm): 120*94
- * Display size(mm): 97*56
- * Installation: Clip installation

1.3.2 EX3G-8050H structure description and dimension



EX3G-8050H



- * Dimension(mm): 151*96*36
- * Cutout size(mm): 143*86
- * Display size(mm): 108*65
- * Installation: Clip installation

1.3.3 EX3G-8070H (HD) structure description and dimension



EX3G-8070H (HD)

X27
X26
X25
X24
X23
X22
X21
X20
X17
X16
X15
X14
X13
X12
X11
X10
X07
X06
X05
X04
X03
X02
X01
X00
S/S

AD11
AD10
AD9
AD8
AD7
AD6
AD5
AD4
AD3
AD2
AD1
AD0
GND
GND
DA0
DA1
DA2
DA3
DA4
DA5
DA6
DA7

Y23
Y22
Y21
Y20
COM4
Y17
Y16
Y15
Y14
COM3
Y13
Y12
Y11
Y10
COM2
Y07
Y06
Y05
Y04
COM1
Y03
Y02
Y01
Y00
COM0



EX3G-8070H(HD)

- * Dimension(mm): 200*146*36
- * Cutout size(mm): 192*138
- * Display size(mm): 154*87
- * Installation: Clip installation

1.3.4 EX3G-8100H structure description and dimension



EX3G-8100H

AD12 AD13 AD14 AD15 AD16 AD17 AD18 AD19 AD20 AD21 AD22 AD23 AD24 AD25 AD26 AD27 AD28 AD29 AD30 AD31 AD32 AD33 AD34 AD35 GND1 GND2 DA0 DA1 DA2 DA3 DA4 DA5 DA6 DA7 — EX3G-8100H-44M-16AD8DA

X30 X31 X32 X33 X34 X35 GND1 GND2 AD0 AD1 AD2 AD3 AD4 AD5 AD6 AD7 AD8 AD9 AD10 AD11 AD12 AD13 AD14 AD15 AD16 AD17 AD18 AD19 AD20 AD21 AD22 AD23 AD24 AD25 AD26 AD27 AD28 AD29 AD30 AD31 AD32 AD33 AD34 AD35 GND1 GND2 DA0 DA1 DA2 DA3 DA4 DA5 DA6 DA7 COM5 — EX3G-8100H-60M-5AD2DA

X27
X26
X25
X24
X23
X22
X21
X20
COM
X17
X16
X15
X14
X13
X12
X11
X10
COM
X07
X06
X05
X04
X03
X02
X01
X00
COM



EX3G-8100H

Y23
Y22
Y21
Y20
COM4
Y17
Y16
Y15
Y14
COM3
Y13
Y12
Y11
Y10
COM2
Y07
Y06
Y05
Y04
COM1
Y03
Y02
Y01
Y00
COM0

- * Dimension(mm): 275*194*36
- * Cutout size(mm): 262*180
- * Display size(mm): 222*125
- * Installation: Clip installation

1.3.6 Introduction of each interface and indicator

POWER: Power indicator, connected to the power light

RUN: PLC running status indicator. This light is on when the PLC is running.

COM: touch screen and PLC communication status indicator, when the two communicate, the light is on

Power terminal: The positive and negative terminals of the DC24V switching power supply are respectively connected to the DC24V and 0V of the power supply terminal.

PLC programming port: two PLC programming ports (MiniB type usb port / RS232), PLC program can be downloaded through 232 programming line or USB cable download

Touch screen programming port: download touch screen configuration program

USB interface: mainly can be directly inserted into the U disk of the file system FAT 32.

SD card: can be inserted into an SD card for storing historical records, etc

For other hardware information, refer to "[EX3G 80Series HMI/PLC All-in-One User Manual](#)"

2. PLC

2.1 PLC Programming notice

The PLC is compatible with GX 8.86/Works 2 and below. If you use other versions of the software, incompatibility may occur.

When the PLC program is downloaded, there is a prompt error: Cannot specify the com port,

GX 8.86 software: Online - Transfer settings change com port;

Works 2: All targets - Change the com port in all connected targets;

If communication error occurs, cable is abnormal If prompted, remove it by powering off, detecting the cable, detecting whether the power is normal, or replacing the computer.

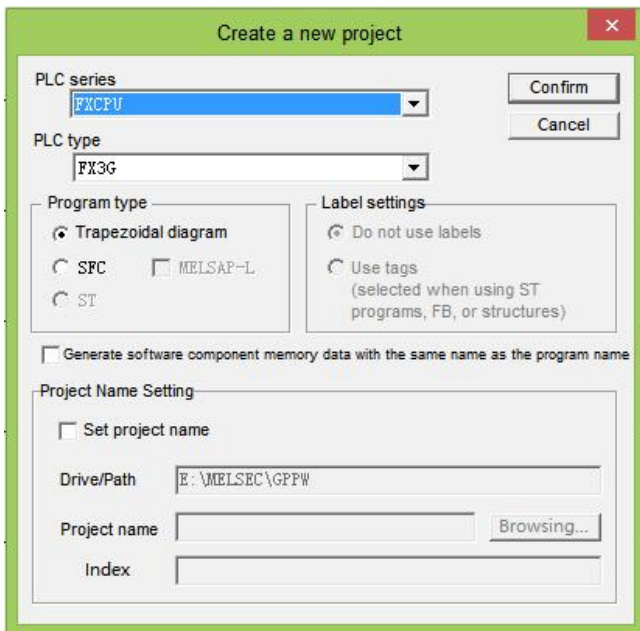

In the Works 2 software version, choose the figure : (Note: the label is forbidden)

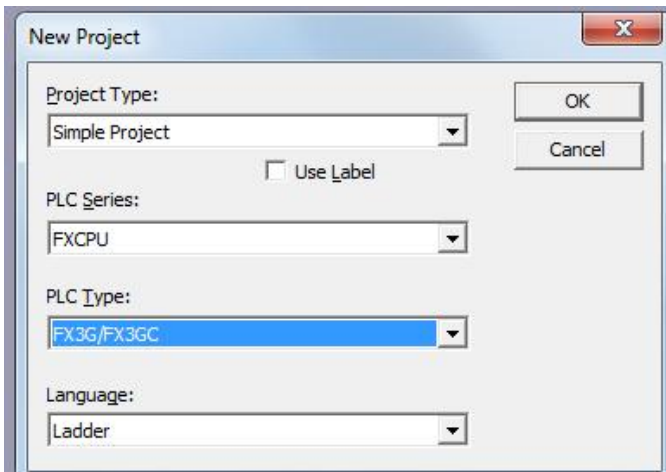

2.2 Soft element table

Name	Contents		
I/O relay			
Input relay	X000~X037	30points	Soft element number is octal Total 60points for I/O
Output relay	Y000~Y037	30points	
Auxiliary relay			
General	M0~M383	384 points	
EEPROM hold	M384~M1535	1152 points	
General*1	M1536~M7679	6144 points	
Special*3	M8000~M8511	512 points	
Status			
Initial state (EEPROM hold)	S0~S9	10 points	
EEPROM hold	S10~S999	990 points	
Signal Alert (EEPROM hold)	S1000~S4095	3096 points	
Timer (ON delay timer)			
100ms	T0~T199	200 points	0.1~3,276.7s
10ms ^{*1}	T200~T245	46 points	0.01~327.67s
1ms accumulative (EEPROM hold)	T246~T249	4 points	0.001~32.767s
100ms accumulative (EEPROM hold)	T250~T255	6 points	0.1~3,276.7s
1ms	T256~T319	64 points	0.001~32.767s
Counter			
General up counter (16bit)	C0~C15	16points	0~32,767 counter
EEPROM hold up counter (16 bit)	C16~C199	184points	0~32,767 counter
General bi-direction (32 bit)	C200~C219	20points	-2,147,483,648~+2,147,483,647 counter
EEPROM hold bi-direction (32 bit)	C220~C234	15points	-2,147,483,648~+2,147,483,647 counter
High-speed counter			
Single-phase single counter input Bi-direction (32 bit) (EEPROM hold)	C235~C245	-2,147,483,648~+2,147,483,647 Counter Software counter Single phase: at most 6 channel, 100kHz Double phase: 1 times frequency:at most 2-3 channels,60KHz; M8198 is 4 times frequency sign of C251. 4 times frequency:at most 2 channels, 24kHz,M8199 is 4 times frequency sign of C253.	
Single-phase double counter input Bi-direction (32 bit) (EEPROM hold)	C246~C250		
Double - phase double counter input Bi-direction (32 bit)(EEPROM hold)	C251~C255		
Data register(32 bit when using in pair)			
General(16bit)	D0~D127	128points	
EEPROM hold (16 bit)	D128~D7999	7872points	
Special (16 bit)	D8000~D8511	512points	
Index (16 bit)	V0~V7,Z0~ Z7	16points	

Extended register • extended file register			
Extended register(16 bit)	R0~R22999	23000points Support power outage maintenance	
	R23000~R23999	1000points Internal use of the system	
Pointer			
JUMP, CALL branch	P0~P1280	1281points	CJ instruct、CALL instruct
Input interrupt	I0□□~I5□□ □	6points	
Timer interrupt	I6□□~I8□□ □	3points	
Counter interrupt	I010~I060	6points	
Nest			
Master control	N0~N7	8points	MC instruct
Constant			
Decimal (K)	16 bit	-32,768~+32,767	
	32 bit	-2,147,483,648~+2,147,483,647	
Hexadecimal (H)	16 bit	0000~FFFF	
	32 bit	00000000~FFFFFFFF	
Real number(E)*3	32 bit	$-1.0 \times 2^{128} \sim -1.0 \times 2^{-126}, 1.0 \times 2^{-126} \sim 1.0 \times 2^{128}$ It can be expressed in decimal and exponential forms	

*1: The 10ms timer is affected by the scanning cycle. If the scanning cycle is 12ms, the timer will be executed once every 12ms..

2.3 Special relay number and content

Num	Content	Remarks	Num	Content	Remarks	
M8000	In RUN, Normally closed		M8224	C224 Increase/decrease counting action	ON:decrease action OFF:increase action	
M8001	In RUN, Normally open		M8225	C225 Increase/decrease counting action		
M8002	After RUN, Output a scan cycle ON		M8226	C226 Increase/decrease counting action		
M8003	After RUN, Output a scan cycle OFF		M8227	C227 Increase/decrease counting action		
M8011	Oscillating in 10ms cycle		M8228	Handwheel function enablement		
M8012	Oscillating in 100ms cycle		M8229	C229 Increase/decrease counting action		
M8013	Oscillating in 1s cycle		M8230	C230 Increase/decrease counting action		
M8014	Oscillating in 1min cycle		M8231	C231 Increase/decrease counting action		
M8020	Zero flag		M8232	C232 Increase/decrease counting action		
M8021	Borrowing flag		M8233	C233 Increase/decrease counting action		
M8022	Carry flag		M8234	C234 Increase/decrease counting action		
M8024	Specify BMOV direction		M8235	C235 Increase/decrease counting action		ON:decrease action OFF:increase action
M8028	During instruction execution, allow interrupt		M8236	C236 Increase/decrease counting action		
M8029	Instruction execution end flag		M8237	C237 Increase/decrease counting action		
M8031	Non-retentive memory is cleared		M8238	C238 Increase/decrease counting action		
M8032	Retentive memory is cleared		M8239	C239 Increase/decrease counting action		
M8033	Memory retention stop		M8240	C240 Increase/decrease counting action		
M8034	Prohibit all output		M8241	C241 Increase/decrease counting action		
M8035	Forced RUN mode		M8242	C242 Increase/decrease counting action		
M8036	Force RUN command		M8243	C243 Increase/decrease counting action		
M8037	Force STOP command		M8244	C244 Increase/decrease counting		

Num	Content	Remarks	Num	Content	Remarks
				action	
M8045	Prohibit reset of all outputs		M8245	C245 Increase/decrease counting action	
M8046	STL state action		M8246	C246 Increase/decrease counting action	
M8047	STL effective control		M8247	C247 Increase/decrease counting action	
M8048	Signal alarm action		M8248	C248 Increase/decrease counting action	
M8049	Signal alarm is effective		M8249	C249 Increase/decrease counting action	
M8050	Input interrupt (I00 is prohibited)		M8250	C250 Increase/decrease counting action	ON:decrease action
M8051	Input interrupt (I10 is prohibited)		M8251	C251 Increase/decrease counting action	OFF:increase action
M8052	Input interrupt (I20 is prohibited)		M8252	C252 Increase/decrease counting action	
M8053	Input interrupt (I30 is prohibited)		M8253	C253 Increase/decrease counting action	
M8054	Input interrupt (I40 is prohibited)		M8254	C254 Increase/decrease counting action	
M8055	Input interrupt (I50 is prohibited)		M8255	C255 Increase/decrease counting action	
M8056	Timer interrupt (I6 is prohibited)		M8340	1st pulse operation temporary control	
M8057	Timer interrupt (I7 is prohibited)		M8342	Interpolation mode	
M8058	Timer interrupt (I8 is prohibited)		M8343	Interpolation mode	
M8059	Counter interrupt is prohibited		M8344	Interpolation relative/absolute coordinate	
M8060	I/O Constitute error		M8348	Interpolation counterclockwise	
M8061	PLC hardware error		M8341	Y000 clear signal output function is valid	
M8062	Serial communication error 0		M8342	Y000 specify the origin return direction	
M8063	Serial communication error 1		M8343	Y000 forward limit	
M8064	Parameter error		M8344	Y000 reverse limit	
M8065	Grammatical error		M8345	Y000 near-point DOG signal logic inversion	
M8066	Loop error		M8346	Y000 zero signal logic inversion	
M8067	Operation error		M8347	Y000 interrupt signal logic inversion	
M8068	Operation error latch		M8348	Y000 positioning command driver	

Num	Content	Remarks	Num	Content	Remarks
M8069	I/O bus detection		M8349	1st pulse stop	
M8075	Sample tracking preparation start command		M8350	2nd pulse operation temporary control	
M8076	Sample tracking execution start command		M8351	Y001 clear signal output function is valid	
M8077	Sample tracking execution		M8352	Y001 specify the origin return direction	
M8078	Sample tracking execution end control		M8353	Y001 forward limit	
M8079	Sampling tracking system area		M8354	Y001 reverse limit	
M8120	Can't use		M8355	Y001 near-point DOG signal logic inversion	
M8121	RS/RS2 command sends standby	Serial Port 2 refer to chapter 2.11.2	M8356	Y001 zero signal logic inversion	
M8122	RS/RS2 command to send request		M8357	Y001 interrupt signal logic inversion	
M8123	RS/RS2 command reception end		M8358	Y001 positioning command driver	
M8124	RS/RS2 command data in reception		M8359	2nd pulse stop	
M8125	MODBUS and Mitsubishi function enablement		M8360	3 rd pulse operation temporary control	
M8128	RD3A/WR3A Receive correct		M8361	Y002 clear signal output function is valid	
M8129	RD3A/WR3A communication timeout		M8362	Y002 specify the origin return direction	
M8151	5 th pulse operation temporary control		M8363	Y002 forward limit	
M8152	6 th pulse operation temporary control		M8364	Y002 reverse limit	
M8153	7 th pulse operation temporary control		M8365	Y002 near-point DOG signal logic inversion	
M8154	8 th pulse operation temporary control		M8366	Y002 zero signal logic inversion	
M8160	XCH's SWAP function		M8367	Y002 interrupt signal logic inversion	
M8161	8-bit processing mode		M8368	Y002 positioning command driver	
M8170	Input X000 pulse capture		M8369	3 rd pulse stop	
M8171	Input X001 pulse capture		M8370	4th pulse operation temporary controlg	
M8172	Input X002 pulse capture		M8371	Y003 clear signal output function is valid	
M8173	Input X003 pulse capture		M8372	Y003 specify the origin return direction	

Num	Content	Remarks	Num	Content	Remarks
M8174	Input X004 pulse capture		M8373	Y003 forward limit	
M8175	Input X005 pulse capture		M8374	Y003 forward limit	
M8176	Input X006 pulse capture		M8375	Y003 near-point DOG signal logic inversion	
M8177	Input X007 pulse capture		M8376	Y003 zero signal logic inversion	
M8192	Programming port protocol and other protocol enablement	Serial port3	M8377	Y003 interrupt signal logic inversion	
M8196	Programming port protocol and other protocol enablement	Serial port2	M8378	Y003 positioning command driver	
M8198	4 times frequency of C251/C252		M8379	4th pulse stop	
M8199	4 times frequency of C253/C255		M8396	C254 function corresponds to input phase	Refer to chapter 2.9.1
M8200	C200 Increase/decrease counting action	ON:decrease action OFF:increase action	M8401	RS2 command sends standby	Serial port 3 Refer to chapter 2.11.3
M8201	C201 Increase/decrease counting action		M8402	RS2 command to send request	
M8202	C202 Increase/decrease counting action		M8403	RS2 command reception end	
M8203	C203 Increase/decrease counting action		M8404	RS2 command data in reception	
M8204	C204 Increase/decrease counting action		M8405	RS2 command data setting ready	
M8205	C205 Increase/decrease counting action		M8408	RD3A/WR3A Receive Completed	CAN communication Refer to chapter 2.11.4
M8206	C206 Increase/decrease counting action		M8409	RD3A/WR3A communication timeout	
M8207	C207 Increase/decrease counting action		M8421	RS2 command sends standby	
M8208	C208 Increase/decrease counting action		M8422	RS2 command to send request	
M8209	C209 Increase/decrease counting action		M8423	RS2 command reception end	
M8210	C210 Increase/decrease counting action		M8424	RS2 command data in reception	
M8211	C211 Increase/decrease counting action		M8425	RS2 command data send completed	
M8212	C212 Increase/decrease counting action		M8426	RS command master-slave and multi-machine mode	
M8213	C213 Increase/decrease counting action		M8427	CAN data standard frame and extended frame	
M8214	C214 Increase/decrease counting action	M8428	CAN communication MODBUS response correct		

Num	Content	Remarks	Num	Content	Remarks
M8215	C215 Increase/decrease counting action		M8429	Communication timeout	
M8216	C216 Increase/decrease counting action		M8432	Interpolation mode	
M8217	C217 Increase/decrease counting action		M8433	Interpolation mode	
M8218	C218 Increase/decrease counting action		M8434	Interpolation relative/absolute coordinate	
M8219	C219 Increase/decrease counting action		M8435	Interpolation counterclockwise	
M8220	C220 Increase/decrease counting action		M8450	5th pulse stop	
M8221	C221 Increase/decrease counting action		M8451	6th pulse stop	
M8222	C222 Increase/decrease counting action		M8452	7th pulse stop	
M8223	C223 Increase/decrease counting action		M8453	8th pulse stop	

2.4 Special register number and content

Num	Content	Remarks	Num	Content	Remarks
D8000	Watchdog timer		D8148	5 th - 8 th pulse acceleration and deceleration time	
D8001	PLC type and system version		D8160		Low
D8002	PLC memory capacity	2...2K steps; 4...4K steps; 8...8K steps; When 16K steps and above, D8002=8,D8102 is corresponded to 16,32,64	D8161	8 th position pulse amount	High
D8003	Memory type	10H:Programmable controller built-in memory	D8169	Restrict access status	
D8010	Scan current value		D8182	Z1 Register contents	
D8011	Scan time minimum		D8183	V1 Register contents	
D8012	Scan time maximum		D8184	Z2 Register contents	
D8013	Second		D8185	V2 Register contents	
D8014	Minute		D8186	Z3 Register contents	
D8015	Hour		D8187	V3 Register contents	
D8016	Date		D8188	Z4 Register contents	
D8017	Month		D8189	V4 Register contents	
D8018	Year		D8190	Z5 Register contents	
D8019	Week		D8191	V5 Register contents	
D8020	Input filter adjustment (0-60ms) initial 10		D8192	Z6 Register contents	
D8030	AD0 analog input value		D8193	V6 Register contents	
D8031	AD1 analog input value		D8194	Z7 Register contents	
D8032	AD2 analog input value		D8195	V7 Register contents	
D8033	AD3 analog input value		D8268	Customize PWM 0~3 division factor	Value range: 1-100000 Hz (32-bit)
D8034	AD4 analog input value		D8269		
D8035	AD5 analog input value		D8278	Customize PWM 4~7 division factor	
D8036	AD6 analog input value		D8279		
D8037	AD7 analog input value		D8340	1 st position pulse amount	Low
D8038	AD8 analog input value		D8341		High
D8039	AD9 analog input value		D8342	Y0 deviation speed Initial value:0	
D8040	AD10 analog input value		D8343	1 st pulse maximum speed	Low
D8041	AD11 analog input value		D8344		High

Num	Content	Remarks	Num	Content	Remarks
D8042	AD12 analog input value		D8345	Y0 crawling speed Initial value: 1000	
D8043	AD13 analog input value		D8346	Y0 Origin return speed	Low
D8044	AD14 analog input value		D8347	Initial value:50000	High
D8045	AD15 analog input value		D8348	1 st pulse acceleration time	
D8050	DA0 analog output value		D8349	1 st pulse deceleration time	
D8051	DA1 analog output value		D8350	2 nd position pulse amount	Low
D8052	DA2 analog output value		D8351		High
D8053	DA3 analog output value		D8352	Y1 deviation speed Initial value:0	
D8054	DA4 analog output value		D8353	2 nd pulse maximum speed	Low
D8055	DA5 analog output value		D8354		High
D8056	DA6 analog output value		D8355	Y1 crawling speed Initial value: 1000	
D8057	DA7 analog output value		D8356	Y1 Origin return speed	Low
D8058	When DA is current, Bit setting	Refer to 5.2	D8357	Initial value:50000	High
D8059	Constant scan time		D8358	2 nd pulse acceleration time	
D8074	X0 Rising edge ring counter value	Low	D8359	2 nd pulse deceleration time	
D8075	[1/6μs unit]	High	D8360	3 rd position pulse amount	Low
D8076	X0 falling edge ring counter value	Low	D8361		High
D8077		[1/6μs unit]	High	D8362	Y2 deviation speed Initial value:0
D8078	X0 pulse width / pulse period	Low	D8363	3 rd pulse maximum speed	Low
D8079	[10μs unit]	High	D8364		High
D8080	X1 Rising edge ring counter value	Low	D8365	Y2 crawling speed Initial value: 1000	
D8081	[1/6μs unit]	High	D8366	Y2 Origin return speed	Low
D8082	X1 falling edge ring counter value	Low	D8367	Initial value:50000	High
D8083	[1/6μs unit]	High	D8368	3 rd pulse acceleration time	
D8084	X1 pulse width / pulse period	Low	D8369	3 rd pulse deceleration time	
D8085	[10μs unit]	High	D8370	4 th position pulse amount	Low
D8086	X3 Rising edge ring counter value	Low	D8371		High
D8087		[1/6μs unit]	High	D8372	Y3 deviation speed Initial value:0
D8088	X3 falling edge ring counter value	Low	D8373	4 th pulse maximum speed	Low
D8089	[1/6μs unit]	High	D8374		High
D8090	X3 pulse width / pulse period	Low	D8375	Y3 crawling speed Initial value:1000	
D8091	[10μs unit]	High	D8376	Y3 Origin return speed	Low
D8092	X4 Rising edge ring counter value	Low	D8377	Initial value:50000	High
D8093	[1/6μs unit]	High	D8378	4 th pulse acceleration time	

Num	Content	Remarks	Num	Content	Remarks
D8094	X4 falling edge ring counter value [1/6μs unit]	Low	D8379	4 th pulse deceleration time	
D8095		High	D8395	Network setting function	Refer to chapter 2.11.5
D8096	X4 pulse width / pulse period [10μs unit]	Low	D8397	ADPRW command serial port position	Refer to chapter 2.11.1
D8097		High	D8398	0~2147483647(1ms) Ring	
D8101	PLC type and system version		D8399	count for incremental actions	
D8102	PLC memory capacity	16...16K steps	D8400	Modbus RTU protocol Communication parameters	Serial port3 Refer to chapter 2.11.3
D8108	Number of special modules connected		D8401	Communication mode	
D8109	Y number of output refresh error		D8406	Number of intervals	
D8120	Modbus RTU protocol Communication parameters	Serial port2 Refer to chapter 2.11.2	D8409	overtime time	
D8121	Master and slave station number		D8410	RS2 header 1, 2 <initial value: STX>	
D8122	RS command to send data remaining points		D8411	RS2 header 3, 4	
D8123	RS command to receive points monitoring		D8412	RS2 trailer 1, 2 <initial value: ETX>	
D8124	RS header <initial value: STX>		D8413	RS2 trailer 3, 4	
D8125	RS trailer <initial value: ETX>	D8414	Master and slave station number		
D8126	When the serial port 2 uses the ADPRW command, the value is 0.	26232 and lower	D8415	RS2 receives the summation calculation result	
D8126	Serial port 2 interval period number	26232 and higher	D8416	RS2 sends summation	
D8127	Specify the starting number of the communication request of the lower computer	Serial port2 Refer to chapter 2.11.2	D8420	Communication parameters	CAN communication Refer to chapter 2.11.4
D8128	Specify the number of data requested by the lower computer communication		D8421	Communication mode	
D8129	Set timeout		D8426	Number of intervals	
D8140	5 th position pulse amount	Low	D8429	overtime time	
D8141		High	D8430	RS2 header 1, 2 <initial value: STX>	
D8142	6 th position pulse amount	Low	D8431	RS2 header 3, 4	
D8143		High	D8432	RS2 trailer 1, 2 <initial value: ETX>	
D8144	7 th position pulse amount	Low	D8433	RS2 trailer 3, 4	
D8145		High	D8434	RS2 receives the summation receive data	

Num	Content	Remarks	Num	Content	Remarks
D8146	5 th -8 th pulse max speed	Low	D8435	RS2 receives the summation calculation result	
D8147		High	D8436	RS2 sends summation	

Specific functions please refer to “Coolmay Full Series PLC Instruction Programming User Manual”

2.5 Function Instructions

2.5.1 List of basic logic instructions

Mnemonic	Name	Features	Available devices
LD	take	Normally open contact logic operation starts	X,Y,M,S,D□.b,T,C
LDI	Negate	Normally closed contact logic operation starts	X,Y,M,S,D□.b,T,C
LDP	Take the rising edge of the pulse	Start of operation to detect rising edge	X,Y,M,S,D□.b,T,C
LDF	Take the falling edge of the pulse	Start of operation to detect falling edge	X,Y,M,S,D□.b,T,C
AND	versus	Series of normally open contacts	X,Y,M,S,D□.b,T,C
ANI	With reverse	Series of normally closed contacts	X,Y,M,S,D□.b,T,C
ANDP	With pulse rising edge	Detect rising edge series connection	X,Y,M,S,D□.b,T,C
ANDF	With the falling edge of the pulse	Series connection detection of falling edges	X,Y,M,S,D□.b,T,C
OR	Or pulse rising edge	Normally open contacts in parallel	X,Y,M,S,D□.b,T,C
ORI	Or reverse	Normally closed contacts in parallel	X,Y,M,S,D□.b,T,C
ORP	Or pulse rising edge	Parallel connection detecting rising edge	X,Y,M,S,D□.b,T,C
ORF	Or pulse falling edge	Parallel connection to detect falling edge	X,Y,M,S,D□.b,T,C
ANB	Block with	Series connection of circuit blocks	-
ORB	Block or	Parallel connection of circuit blocks	-
MPS	Push stack	Push onto the stack	-
MRD	Read stack	Read stack	-
MPP	Unstack	Pop the stack	-
INV	Negate	Inversion of operation result	-
MEP	M.E.P	Conduction on rising edge	-
MEF	M..EF	Conduction on falling edge	-
OUT	Output	Coil drive	Y,M,S,D□.b,T,C
SET	Position	Movement retention	Y,M,S,D□.b
RST	Reset	Clear action keeps, register cleared	Y,M,S,D□.b,T,C, D,R,V,Z
PLS	pulse	Differential output on rising edge	Y,M
PLF	Falling edge pulse	Differential output on falling edge	Y,M
MC	Master	Connection circle command for common series point	Y,M
MCR	Master reset	Instruction to eliminate common series point	-
NOP	No operation	No action	-
END	End	End of the program and I/O and return to the beginning	-

Applied instruction can be divided into the following 18 kinds.

1	Data move instructions
2	Data conversion instructions
3	Comparison instructions
4	Arithmetic operation instructions
5	Logical operation instructions
6	Special function instructions
7	Rotate instructions
8	Shift instruction
9	Data operation instructions
10	Character string operation instructions
11	Program flow control instructions
12	I/O refresh instructions
13	Real time clock control instructions
14	Pulse output/positioning control instructions
15	Serial communication
16	Special block/unit control instructions
17	Extension register/extension file register control instructions
18	Other handy instruct

1. Data move instructions

Mnemonic	FNC No.	Function	Support
MOV	12	Move	★
SMOV	13	Shift Move	★
CML	14	Compliment	★
BMOV	15	Block Move	★
FMOV	16	Fill Move	★
PRUN	81	Parallel Run (Octal Mode)	★
XCH	17	Exchange	★
SWAP	147	Byte Swap	★
EMOV	112	Floating Point Move	★
HCMOV	189	High Speed Counter Move	★

2. Data conversion instructions

Mnemonic	FNC No.	Function	Support
BCD	18	Conversion to Binary Coded Decimal	★
BIN	19	Conversion to Binary	★
GRY	170	Decimal to Gray Code Conversion	★
GBIN	171	Gray Code to Decimal Conversion	★
FLT	49	Conversion to Floating Point	★
INT	129	Floating Point to Integer Conversion	★
EBCD	118	Floating Point to Scientific Notation Conversion	★

EBIN	119	Scientific Notation to Floating Point Conversion	★
RAD	136	Floating Point Degree to Radian Conversion	★
DEG	137	Floating Point Radian to degree Conversion	★

3. Comparison instructions

Mnemonic	FNC No.	Function	Support
LD=	224	Contact compare LD (S1)=(S2)	★
LD>	225	Contact compare LD (S1)>(S2)	★
LD<	226	Contact compare LD (S1)<(S2)	★
LD<>	228	Contact compare LD (S1)≠(S2)	★
LD<=	229	Contact compare LD (S1)≦(S2)	★
LD>=	230	Contact compare LD (S1)≧(S2)	★
AND=	232	Contact compare AND (S1)=(S2)	★
AND>	233	Contact compare AND (S1)>(S2)	★
AND<	234	Contact compare AND (S1)<(S2)	★
AND<>	236	Contact compare AND (S1)≠(S2)	★
AND<=	237	Contact compare AND (S1)≦(S2)	★
AND>=	238	Contact compare AND (S1)≧(S2)	★
OR=	240	Contact compare OR (S1)=(S2)	★
OR>	241	Contact compare OR (S1)>(S2)	★
OR<	242	Contact compare OR (S1)<(S2)	★
OR<>	244	Contact compare OR (S1)≠(S2)	★
OR<=	245	Contact compare OR (S1)≦(S2)	★
OR>=	246	Contact compare OR (S1)≧(S2)	★
CMP	10	Compare	★
ZCP	11	Zone Compare	★
ECMP	110	Floating Point Compare	★
EZCP	111	Floating Point Zone Compare	★
HSCS	53	High speed counter set	★
HSCR	54	High speed counter reset	★
HSZ	55	High Speed Counter Zone Compare	★
HSCT	280	High speed counter table compare	★
BKCMP=	194	Block compare (S1)=(S2)	★
BKCMP>	195	Block compare (S1)>(S2)	★
BKCMP<	196	Block compare (S1)<(S2)	★
BKCMP<>	197	Block compare (S1)≠(S2)	★
BKCMP<=	198	Block compare (S1)≦(S2)	★
BKCMP>=	199	Block compare (S1)≧(S2)	★

4. Arithmetic operation instructions

Mnemonic	FNC No.	Function	Support
ADD	20	Addition	★
SUB	21	Subtraction	★
MUL	22	Multiplication	★
DIV	23	Division	★
EADD	120	Floating Point Addition	★
ESUB	121	Floating Point Subtraction	★
EMUL	122	Floating Point Multiplication	★
EDIV	123	Floating Point Division	★
BK+	192	Block Data Addition	★
BK-	193	Block Data Subtraction	★
INC	24	Increase	★
DEC	25	Decrement	★

5. Logical operation instructions

Mnemonic	FNC No.	Function	Support
WAND	26	Word AND	★
WOR	27	Word OR	★
WXOR	28	Word Exclusive OR	★

6. Special function instructions

Mnemonic	FNC No.	Function	Support
SQR	48	Square Root	★
ESQR	127	Floating Point Square Root	★
EXP	124	Floating Point Exponent	★
LOGE	125	Floating Point Natural Logarithm	★
LOG10	126	Floating Point Common Logarithm	★
SIN	130	Floating Point Sine	★
COS	131	Floating Point Cosine	★
TAN	132	Floating Point Tangent	★
ASIN	133	Floating Point Arc Sine	★
ACOS	134	Floating Point Arc Cosine	★
ATAN	135	Floating Point Arc Tangent	★
RND	184	Random Number Generation	★

7. Rotate instructions

Mnemonic	FNC No.	Function	Support
ROR	30	Rotation Right	★
ROL	31	Rotation Left	★
RCR	32	Rotation right With Carry	★
RCL	33	Rotation Left with Carry	★

8. Shift instructions

Mnemonic	FNC No.	Function	Support
SFTR	34	Bit Shift Right	★
SFTL	35	Bit Shift Left	★
SFR	213	Bit Shift Right with Carry	★
SFL	214	Bit Shift Left with Carry	★
WSFR	36	Word Shift Right	★
WSFL	37	Word Shift left	★
SFWR	38	Shift Write [FIFO/FILO Control]	★
SFRD	39	Shift Read [FIFO Control]	★
POP	212	Shift Last Data Read [FILO Control]	★

9. Data operation instructions

Mnemonic	FNC No.	Function	Support
ZRST	40	Zone Reset	★
DECO	41	Decode	★
ENCO	42	Encode	★
MEAN	45	Mean	★
WSUM	140	Sum of Word Data	★
SUM	43	Sum of Active Bits	★
BON	44	Check Specified Bit Status	★
NEG	29	Negation	★
ENEG	128	Floating Point Negation	★
WTOB	141	WORD to BYTE	★
BTOW	142	BYTE to WORD	★
UNI	143	4-bit Linking of Word Data	★
DIS	144	4-bit Grouping of Word Data	★
CCD	84	Check Code	★
CRC	188	Cyclic Redundancy Check	★
LIMIT	256	Limit Control	★
BAND	257	Dead Band Control	★
ZONE	258	Zone control	★
SCL	259	Scaling (Coordinate by Point Data)	★
SCL2	269	Scaling 2 (Coordinate by X/Y Data)	★
SORT	69	Sort Tabulated Data	★
SORT2	149	Sort Tabulated Data 2	★
SER	61	Search a Data Stack	★
FDEL	210	Deleting Data from Tables	★
FINS	211	Inserting Data to Tables	★

10. String processing instruction

Mnemonic	FNC No.	Function	Support
ESTR	116	Floating Point to Character String Conversion	★
EVAL	117	Character String to Floating Point Conversion	★
STR	200	BIN to Character String Conversion	★

VAL	201	Character String to BIN Conversion	★
DABIN	260	Decimal ASCII to BIN Conversion	★
BINDA	261	BIN to Decimal ASCII Conversion	★
ASCI	82	Hexadecimal to ASCII Conversion	★
HEX	83	ASCII to Hexadecimal Conversion	★
\$MOV	209	Character String Transfer	★
\$+	202	Link Character Strings	★
LEN	203	Character String Length Detection	★
RIGH	204	Extracting Character String Data From the Right	★
LEFT	205	Extracting Character String Data from the Left	★
MIDR	206	Random Selection of Character Strings	★
MIDW	207	Random Replacement of Character Strings	★
INSTR	208	Character string search	★
COMRD	182	Read Device Comment Data	★

11. Program flow control instructions

Mnemonic	FNC No.	Function	Support
CJ	00	Conditional Jump	★
CALL	01	Call Subroutine	★
SRET	02	Subroutine Return	★
IRET	03	Interrupt Return	★
EI	04	Enable Interrupt	★
DI	05	Disable Interrupt	★
FEND	06	Main Routine Program End	★
FOR	08	Start a FOR/NEXT Loop	★
NEXT	09	End a FOR/NEXT Loop	★

12. I/O refresh instructions

Mnemonic	FNC No.	Function	Support
REF	50	Refresh	★
REFF	51	Refresh and Filter Adjust	★

13. Real time clock control instructions

Mnemonic	FNC No.	Function	Support
TCMP	160	RTC Data Compare	★
TZCP	161	RTC Data Zone Compare	★
TADD	162	RTC Data Addition	★
TSUB	163	RTC Data Subtraction	★
TRD	166	Read RTC data	★
TWR	167	Set RTC data	★
HTOS	164	Hour to Second Conversion	★
STOH	165	Second to Hour Conversion	★

14. Pulse output/positioning control instruction

Mnemonic	FNC No.	Function	Support
ABS	155	Absolute Current Value Read	★
DSZR	150	DOG Search Zero Return	★
ZRN	156	Zero Return	★
TBL	152	Batch Data Positioning Mode	★
DVIT	151	Interrupt Positioning	★
DRVI	158	Drive to Increment	★
DRVA	159	Drive to Absolute	★
PLSV	157	Variable Speed Pulse Output	★
PLSY	57	Pulse Y Output	★
PLSR	59	Acceleration/Deceleration Setup	★

15. Serial communication instructions

Mnemonic	FNC No.	Function	Support
RS	80	Serial Communication	★
R(S2)	87	Serial Communication 2	★
IVCK	270	Inverter Status Check	
IVDR	271	Inverter Drive	
IVRD	272	Inverter Parameter Read	
IVWR	273	Inverter Parameter Write	
IVBWR	274	Inverter Parameter Block Write	
IVMC	275	Inverter multiple command	
ADPRW	276	MODBUS read and write	★

16. Special block/unit control instructions

Mnemonic	FNC No.	Function	Support
FROM	78	Read From a Special Function Block	★
TO	79	Write To a Special Function Block	★
RD3A	176	Read form Dedicated Analog Block	★
WR3A	177	Write to Dedicated Analog Block	★
RBFM	278	Divided BFM Read	
WBFM	279	Divided BFM Write	

17. Extension register/extension file register control instructions

Mnemonic	FNC No.	Function	Support
LOADR	290	Load From ER	
SAVER	291	Save to ER	
RWER	294	Rewrite to ER	
INITR	292	Initialize R and ER	
INITER	295	Initialize ER	
LOGR	293	Logging R and ER	

18. Other handy instructions

Mnemonic	FNC No.	Function	Support
WDT	07	Watchdog Timer Refresh	★
ALT	66	Alternate State	★
ANS	46	Timed Annunciator Set	★
ANR	47	Annunciator Reset	★
HOUR	169	Hour Meter	★
RAMP	67	Ramp Variable Value	★
SPD	56	Speed Detection	★
PWM	58	Pulse Width Modulation	★
DUTY	186	Timing Pulse Generation	★
PID	88	PID Control Loop	★
ZPUSH	102	Batch Store of Index Register	★
ZPOP	103	Batch POP of Index Register	★
TTMR	64	Teaching timer	★
STMR	65	Special timer	★
ABSD	62	Absolute Drum Sequencer	★
INCD	63	Incremental Drum Sequencer	★
ROTC	68	Rotary Table Control	★
IST	60	Initial state	★
MTR	52	Input Matrix	★
TKY	70	Ten Key Input	★
HKY	71	Hexadecimal Input	★
DSW	72	Digital switch (thumbwheel input)	★
SEGD	73	Seven Segment Decoder	★
SEGL	74	Seven Segment With Latch	★
ARWS	75	Arrow Switch	★
ASC	76	ASCII code data input	★
PR	77	Print (ASCII Code)	★
VRRD	85	Volume Read	★
VRSC	86	Volume Scale	★

2.6 Analog input

This section refers to the software version query, the version number is stored in the special register D8001, D8101, if necessary, please query the value of D8001.

Input precision of coolmay CX3G/FX3GC PLC and EX3G plc hmi all-in-one is 12-bit, directly read the corresponded register value of each analog while using.

Environment temperature is only used in thermocouple.

When Analog input is NTC10K, B value is 3435.

2.6.1 Analog input (temperature)

Input signal	Range	Register value	Resolution	Accuracy (Total Measuring)	Remark
--------------	-------	----------------	------------	----------------------------	--------

				range)	
K-type thermocouple	Room temperature~1100°C	Room temperature~11000	0.1°C	1%	Non-grounded wiring is required for thermocouple type
K-type thermocouple (Negative temp)	-210~1200°C	-2100~12000	0.1°C	1%	
T-type thermocouple	Room temperature~420°C	Room temperature~4200	0.1°C	1%	
T-type thermocouple (Negative temp)	-210~420°C	-2100~4200	0.1°C	1%	
S-type thermocouple	Room temperature~1710°C	Room temperature~17100	0.1°C	1%	
S-type thermocouple (Negative temp)	-26~1710°C	-260~17100	0.1°C	1%	
J-type thermocouple	Room temperature~800°C	Room temperature~8000	0.1°C	1%	
J-type thermocouple (Negative temp)	-90~950°C	-900~9500	0.1°C	1%	
E-type thermocouple	Room temperature~600°C	Room temperature~6000	0.1°C	1%	
E-type thermocouple (Negative temp)	-110~730°C	-1100~7300	0.1°C	1%	
PT100/PT1000	-200~500°C	-2000~5000	0.1°C	1%	
NTC50K/100K (The default value of B is 3435)	-48~210°C	-480~2100	0.1°C	1%	
NTC10K (The default value of B is 3435)	-48~110°C	-480~1100	0.1°C	1%	
Voltage	0~10V/0-5V/	0~4000	2.5mV	1%	12 bit precision
Negative Voltage	-10~10V/-5~5V	0~4000	5mV/2.5mV	1%	
Current Type1	0~20mA	0~4000	5uA	1%	

Current Type2	4~20mA	0~4000	4uA	1%	16 bit precision
Voltage analog	0-10V/0-5V	0~32000	0.3mV/0.15mV	1%	
Negative voltage analog	-10~10V/-5~5V	0~32000	0.3mV/0.15mV	1%	
Current analog Type1	0~20mA	0~32000	0.6uA	1%	
Current analog Type2	4~20mA	0~32000	0.5uA	1%	

The transmitter which is integrated inside PLC is one of the above table or mixed ones, it is up to customers' need when ordering.

2.6.2 Analog input reading

Supports direct reading of from instructions or registers. For example, from K0 K0 D400 K16, 16 analog inputs are read out, ranging from 0 to 10V.

Register direct reading: D [8030]~D [8045] are the output values set for the corresponding type, and the constant scan time is changed to D8059, which is started by M8039;

NO	Register Value
AD0	D8030
AD1	D8031
AD2	D8032
AD3	D8033
AD4 (Environment temperature)	D8034
AD5	D8035
AD6	D8036
AD7	D8037
AD8	D8038
AD9	D8039
AD10	D8040
AD11	D8041
AD12	D8042
AD13	D8043
AD14	D8044
AD15	D8045

When there are thermocouple types in the analog input, a maximum of 15 channels can be made, where AD4 is the ambient temperature of the thermocouple. When there is no thermocouple type, 16 channels can be made.

The values of the thermistor NTC are shown in the following table:

NO	Register Value
AD0	R23660

AD1	R23661
AD2	R23662
AD3	R23663
AD4	R23664
AD5	R23665
AD6	R23666
AD7	R23667
AD8	R23668
AD9	R23669
AD10	R23670
AD11	R23671
AD12	R23672
AD13	R23673
AD14	R23674
AD15	R23675

R23960 starts as the zero correction value and defaults to 0 (i.e. size correction).

The 16 registers starting from R23620 correspond to the real-time sampling values of 0-10V or 0-20mA.

2.6.3 Analog input sampling

Filtering cycles=(R23600~R23615)* PLC scanning time, if R23600=1, One PLC scan cycle sample one time and change the 1st analog input value for one time. The larger R23600~R23615 value is, the result is more stable.

R23600~R23615 is filtering cycles, default is 100 (range 2~20000), data can't be equal to or less than 0;

D8073 is smoothing filter coefficients of all analog input, range: 0~999

2.6.4 Demo example

Below is an example of EX3G-H 1 channel temperature analog AD0 acquisition. The program reads the values as follows:

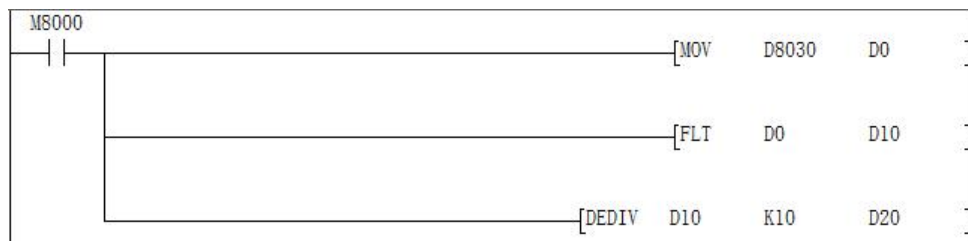

Connect the signal terminal of the temperature sensor to the AD0 input of the PLC and the other end to the GND of the analog input port.

When the PLC is running, the value of the data register D8030 corresponding to AD0 will be transmitted to D0, the value of D0 will be put into D10 after floating point operation, and then the floating point number division operation will be performed on D10, and then operation result will

be put into D20, the result D20 is the actual Temperature value.

In the ladder diagram, you can also directly divide the value of D8030.

- Note:** When the input is 0-10V analog, the actual analog value = register reading / 400;
 When the input is temperature, the actual temperature value = register reading/10;
 When the input is 0-20mA analog, the actual analog value = register reading / 200;
 When the input is 4-20 mA analog, the actual analog value = register reading / 250 + 4.

The analog correction is corrected for the size. The following figure is an example of correcting the AD0 temperature after acquisition:

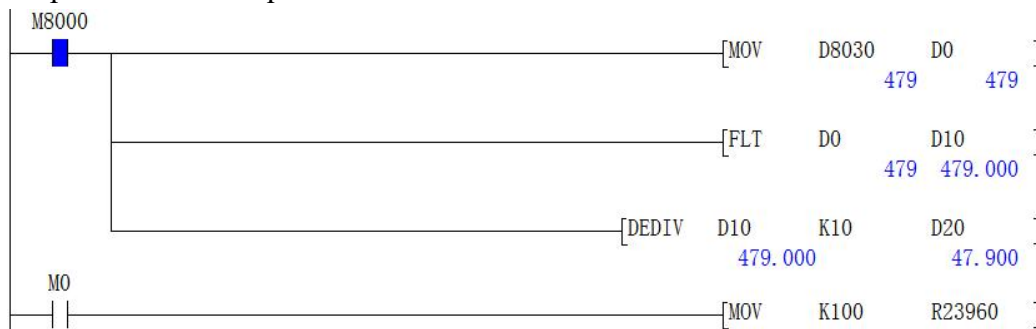

If the current temperature is 37.9°C, the actual test is 47.9 ° C, the error is 10 ° C, you need to modify the size correction register, show as below:

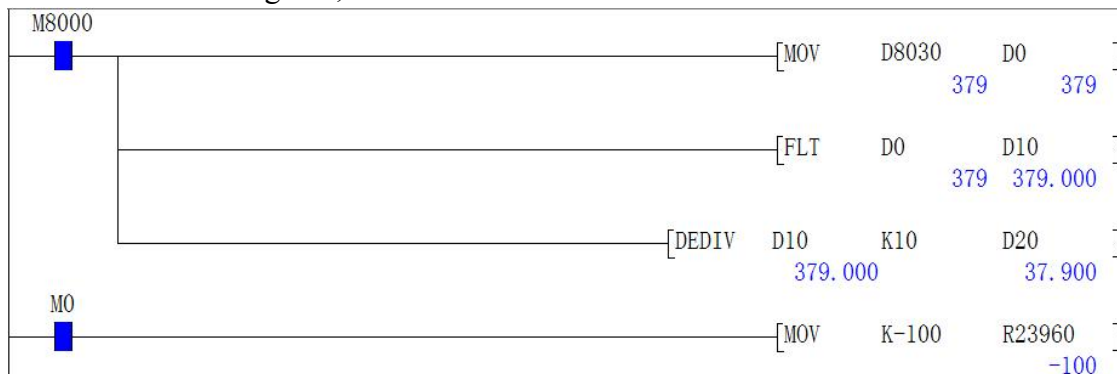

In the above figure, when M0 is closed, the value -100 is transmitted to the correction register

R23960, and now you can see that the value of the actual measured temperature D20 is close to the actual temperature which is 37.9 °C.

2.7 Analog output

Analog output range 0~4000, precision is 12 bit. Support TO instruction or register assignment operation directly.

Adopts TO K0 K0 D500 K8, 8 channels 0~10V or 0~20mA analog output.

Register assignment operation directly: D8050~D8057.

When the analog output is current, the bit of D8058 needs to be set:

When the default D8058.0~D8058.7=0, it means 0~20mA; when D8058.0~D8058.7=1, it means 4~20mA.

DA register	Range	Output type
-------------	-------	-------------

Example:
shows the
voltage
output.

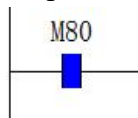

DA0	D8050	0-4000	When D8058.0~D8058.7=0 Means 0~20mA; When D8058.0~D8058.7=1 Means 4~20mA。
DA1	D8051	0-4000	
DA2	D8052	0-4000	
DA3	D8053	0-4000	
DA4	D8054	0-4000	
DA5	D8055	0-4000	
DA6	D8056	0-4000	
DA7	D8057	0-4000	

Below
0-10V
analog

At this point, use a multimeter to check the voltage of the DA0 terminal, that is, the multimeter's red pen is connected to the DA0 terminal, and the black pen is connected to the GND terminal. The multimeter is displaying 5V voltage value.

2.8 Weighing Function Description

EX3G-8070H/HD and EX3G-8100H can be equipped with 2 or 4 weighing functions (cannot coexist with analog input), converted into high-precision 24 bit AD designed for electronic weighing, supporting selection of filtering and setting of filtering times, and equipped with fault detection relay, 64 gain, and fixed rate of 80Hz;;

The special registers are as follows:

Weighing Function Description	First weighing	Second weighing	Third weighing	Fourth weighing
Weighing value (32 bits)	R23700 R23701	R23702 R23703	R23704 R23705	R23706 R23707
Number of filter cycles default is 100 (range 2~20000)	R23605	R23606	R23607	R23608
Calibration	R23985	R23986	R23987	R23988

Wiring diagram (For details, please refer to the EX3G-80 series all-in-one machine user manual):

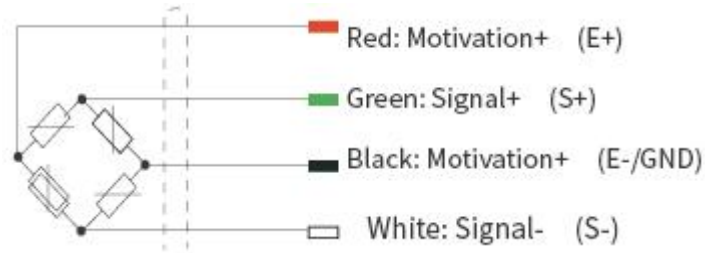

For detailed cases, please refer to the official website "EX3G-80 Series Weighing Routine"

2.9 PID instruction

2.9.1 Outline

This command is used to perform PID control that changes the output value according to the amount of change in the input.

2.9.2 PID instruction format and parameter description

Instruction format:

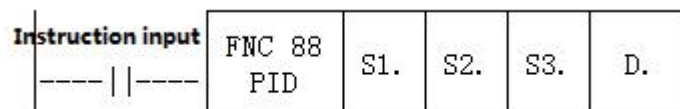

Parameter Description:

Operand Type	Content	Data Type	Word software component
S1.	Save data register number of the target value (SV)	BIN16 bit	D,R
S2.	Save data register number of the measured value (PV)	BIN16 bit	D,R
S3.	Save the data register number of the parameter	BIN16 bit	D,R
D.	Save data register number of the output register (MV)	BIN16 bit	D,R

2.9.3 Function and action description

16-bit operation (PID): After setting the target value S1., the measured value S2., and the parameters S3~S3+6 in the execution program, the operation result (MV) is saved to the output value D. every sampling time S3. .

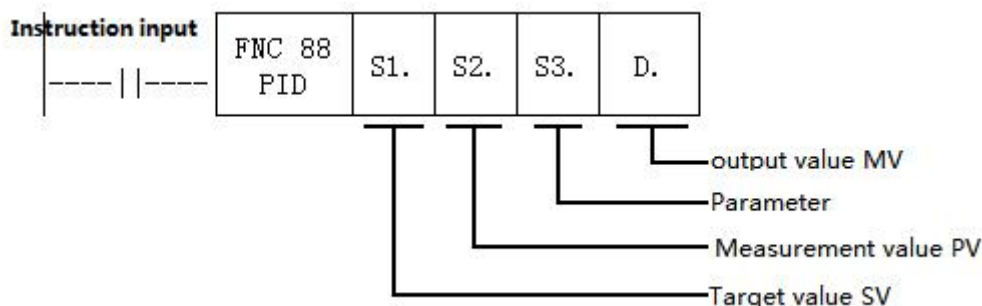

Setting item

Setting item		Content	Occupied points
S1.	Target value(SV)	Set target value (SV) PID instruction does not change the setting contents	1 point
S2.	Measured value(PV)	The input value of the PID operation	1 point
S3.	Parameter	Auto-tuning: step response method a) ACT setting: when bit1,bit2,bit5 are all not "0",occupy 25points Soft Component starting from the Initial Soft Component specified in S3. b) ACT setting: when bit1,bit2,bit5 are all "0",occupy 20points Soft Component starting from the Initial Soft Component specified in S3.	25 points 20 points
D.	Output value (MV)	Auto-tuning: step response method Set the step output value on the user side before the instruction is driven. During the auto-tuning process, the MV output cannot be changed on the side of the PID instruction.	1 point

Parameter list S3.~S3.+28

Setting item		Setting content	Remark
S3.	Sampling time(Ts)	1~32767(ms)	Value shorter than the calculation period can't be run
S3.+1	ACT	bit0	0: positive action; 1: reverse action. Action direction (ACT)
		bit1	0: No input change alarm; 1: Input change amount alarm is valid.
		bit2	0: No output change alarm; 1: Output change amount alarm is valid. Do not turn ON bit2 and bit5 at the same time
		bit3	Can't use
		bit4	0: Auto-tuning doesn't work; 1: Perform auto-tuning.

		bit5	0: No output value upper and lower limit setting; 1: The output value upper and lower limits are valid.	Do not turn ON bit2 and bit5 at the same time
		bit6	0: Step response method.	Auto-tuning mode
		bit7~bit15	Can't use	
S3.+2	Input filter constant (α)		0~99(%)	0 means no input filtering
S3.+3	Proportional gain ()		1~32767(%)	
S3.+4	Integration time()		0~32767(*100ms)	0 means as ∞ processing (no points)
S3.+5	Differential gain ()		0~100(%)	0 means no derivative gain
S3.+6	Derivative time ()		0~32767(*10ms)	0 means no differential processing
S3.+7 ... S3.+19	PID operation internal processing occupied, please do not change the data.			
S3.+20*1	Input change amount (increase side) alarm set value		0~32767	(ACT): Valid when S3.+1 bit1=1
S3.+21*1	Input change amount (decrease side) alarm set value		0~32767	(ACT): Valid when S3.+1 bit1=1
S3.+22*1	Output change amount (increase side) alarm set value		0~32767	(ACT): Valid when S3.+1 bit2=1, bit5=0
	Output upper limit set value		-32768~32767	(ACT): Valid when S3.+1 bit2=0, bit5=1
S3.+23*1	Output change amount (decrease side) alarm set value		0~32767	(ACT): Valid when S3.+1 bit2=1, bit5=0
	Output lower limit set value		-32768~32767	(ACT): Valid when S3.+1 bit2=0, bit5=1
S3.+24*1	Alarm output	bit0	0: The input change amount (increase side) does not overflow; 1: Input change amount (increase side) overflow.	(ACT): Valid when S3.+1 bit1=1 or bit2=1
		bit1	0: The input change amount (reduction side) does not overflow; 1: Input change amount (reduction side) overflow.	
		bit2	0: The output change amount (increase side) does not	

			overflow; 1: Output change amount (increase side) overflow.	
		bit3	0: The output change amount (reduction side) does not overflow; 1: Output change amount (reduction side) overflow.	

*1: When S3+1 action setting (ACT) bit1=1, bit2=1 or bit5=1, S3+20~24 is occupied.

2.9.4 Notice

When using multiple instructions: It can be executed multiple times at the same time (the number of loops is not limited), but note that the S3 and D devices used in the operation cannot be repeated.

Occupied points of parameter S3. : Step response method

- 1) ACT setting: when bit1,bit2,bit5 are all not "0",occupy 25points Soft Component starting from the Initial Soft Component specified in S3.
- 2) ACT setting: when bit1,bit2,bit5 are all "0",occupy 20points Soft Component starting from the Initial Soft Component specified in S3.

Step response mode: The self-tuning mode in the PID instruction has only a step response mode, and the step value is S0+22, which is the upper limit value.

When specifying the soft component in the power failure holding area: If D. is specified in the program to hold the data register in the power failure, needs to clear the specified register at the time of program start up.

Action flag: Bit 0=0 of S3+1 is a positive action, and bit0=1 is a reverse action;
When heating, is reverse action.

2.9.5 Example

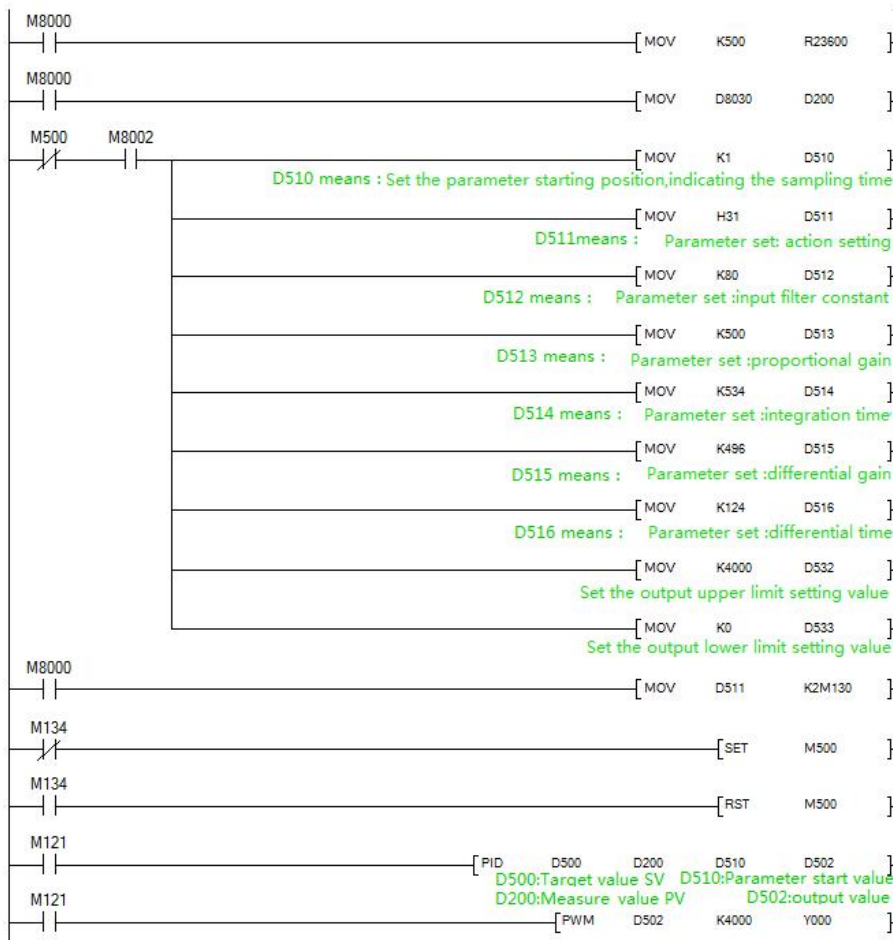

2.10 Application of high speed counter

2.10.1 Assignment table of built-in high speed counter

EX3G-80 series PLC high-speed counting conventional 6-way single-phase 60KHz or 2-way AB (Z) phase 30KHz+1-way AB phase 5KHz; Among them, the dual phase dual count input defaults to 1 harmonic.

Counter type	No.	Input assignment							
		X000	X001	X002	X003	X004	X005	X006	X007
Single phase single counter input	C235	U/D							
	C236		U/D						
	C237			U/D					
	C238				U/D				
	C239					U/D			
	C240						U/D		
	C241	U/D	R						
	C242			U/D	R				
	C243					U/D	R		
	C244	U/D	R						S
C245			U/D	R				S	
Single phase double counter	C246	U	D						
	C247	U	D	R					

input	C248				U	D	R		
	C249	U	D	R				S	
	C250				U	D	R		S
AB phase double counter input	C251	A	B						
	C252	A	B	R					
	C253				A	B	R		
	C254							A	B
	C255				A	B	R		S

U: up counter

D: down counter

A: A phase input

B: B phase input

R: External reset input

S: External start input

Single phase: at most 6 channels, max frequency is 60KHz

AB phase: 1 times frequency: 2 channels 30KHz+1 channel 5KHz;

4 times frequency: at most 2 channels, Max frequency is 24KHz;

2.10.2 Related device

1.For switching up/down counting of Single phase single counter

Type	Counter number	Designated device	Up counting	Down counting
Single phase single counter input	C235	M8235	OFF	ON
	C236	M8236		
	C237	M8237		
	C238	M8238		
	C239	M8239		
	C240	M8240		
	C241	M8241		
	C242	M8242		
	C243	M8243		
	C244	M8244		
	C245	M8245		

2.For monitoring the up/down counting direction of Single phase double counter and AB phase double counter

Type	Counter number	Designated device	Up counting	Down counting
Single phase double counter input	C246	M8246	OFF	ON
	C247	M8247		
	C248	M8248		
	C249	M8249		
	C250	M8250		
AB phase double counter input	C251	M8251	OFF	ON
	C252	M8252		
	C253	M8253		

	C254	M8254		
	C255	M8255		

3.For High-speed counter function switching

Device name	Name	Content
M8198	Function switching device	1 times/4 times switching device for C251/C252
M8199		1 times/4 times switching device for C253/C255

2.11.Application of high speed pulse

2.11.1 high speed pulse output

Gu Mei EX3G-80 series PLC high-speed pulse output conventional 8 channels, Y0~Y3 each 100KHz, Y4~Y7 each 10KHz, supports variable speed, and the initial/final speed of start/stop is 0. The chart is as follows: (Taking acceleration and deceleration time D8148 as an example).

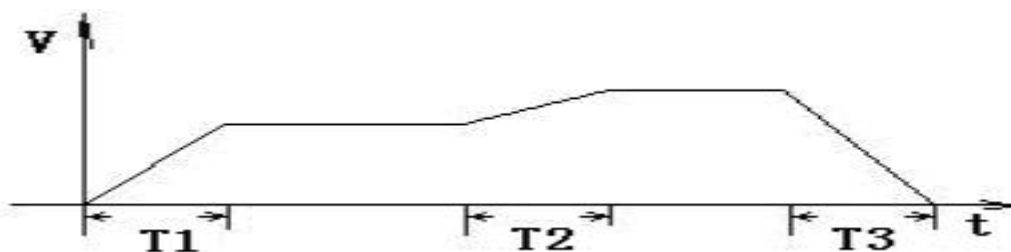

Acceleration/deceleration time T calculation= (target speed-current speed) * acceleration/deceleration time/maximum speed.

For example, target speed = 50000, current speed = 20000, acceleration time 100 (ms), maximum speed = 100,000, $T = 30$ ms.

CX3G: 8 channels of pulse, the last 4 channels of acceleration and deceleration = D8148, the maximum speed is D8146, D8147.

PLSY, ZRN, PLSV, DRVI, DRVA, DVIT, DSZR, only Y0-Y3 supports DVIT (interrupt positioning), DSZR (ordinary return with DOG search) instructions.

Pulse point Function Description	Y0	Y1	Y2	Y3	Y4	Y5	Y6	Y7
Pulse operation monitoring	M8340	M8350	M8360	M8370	M8151	M8152	M8153	M8154
Position pulse (32bit)	D8340 D8341	D8350 D8351	D8360 D8361	D8370 D8371	D8140 D8141	D8142 D8143	D8144 D8145	D8160 D8161
accelerate / decelerate time	D8348 D8349	D8358 D8359	D8368 D8369	D8378 D8379		D8148	D8148	D8148
Pulse stop bit	M8349	M8359	M8369	M8379	M8450	M8451	M8452	M8453
Maximum speed	D8343	D8353	D8363	D8373	D8146	D8146	D8146	D8146

	D8344	D8354	D8364	D8374	D8147	D8147	D8147	D8147
--	-------	-------	-------	-------	-------	-------	-------	-------

The original FX3G pulse program can be used directly.

All the instruction support 8 channels pulse, except DVIT、DSZR which support 4 channels.

2.11.2 Circular interpolation

2.11.2.1 Normal Interpolation Function

The special flags when setting the interpolation route are as shown in the following table:

Interpolation mode	M8433	M8432
Line Interpolation	0	1
Center interpolation	1	0
Radius interpolation	1	1

The direction and coordinates of the center and radius interpolation are as shown in the following table:

Clockwise	M8435=0
Counterclockwise	M8435=1
Relative position	M8434=0
Absolute position	M8434=1

M8348=0, clockwise; M8348=1, anticlockwise.

M8344=0, relative position; M8344=1, absolute position.

D8340 shows the current address of X axis, D8350 shows the current address of Y axis.

In CoolMay 3G PLC, interpolation motion still adopts DPLSR for pulse output.

Description of the Operand:

Instruction input	DPLSR	S.	S.+2	S.+4	D.
-------------------	-------	----	------	------	----

S. represents the pulse frequency, that is, the speed of the interpolation motion.

S.+2 represents the X-axis target address.

S.+4 represents the Y-axis target address.

D.: Specify the Y number with pulse output (Currently only supports Y0, the corresponding direction is Y4; Y1 is another axis, the corresponding direction is Y5).

X axis: Y0 pulse, Y4 direction

Y axis: Y1 pulse, Y5 direction

In the center interpolation mode:

S.+6 represents the center X coordinate address.

S.+8 represents the center Y coordinate address.

In radius interpolation mode:

S.+6 represents the radius length. When it is positive, the path is a small circle; when it is a negative value, the path is a large circle.

For example: DPLSR D100 D102 D104 Y000

In the linear interpolation: D100 speed, D102 is the X-axis target address, and D104 is the Y-axis target address. Y0 and Y1 respectively pulse the X-axis and Y-axis.

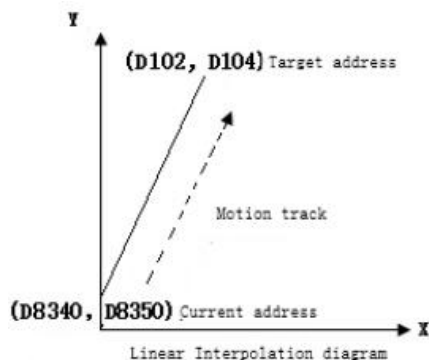

In the Center interpolation: D100 speed, D102 is the X-axis target address, D104 is the Y-axis target address, and D106 is the center X address. D108 is the center Y address. Y0 and Y1 respectively pulse the X-axis and Y-axis.

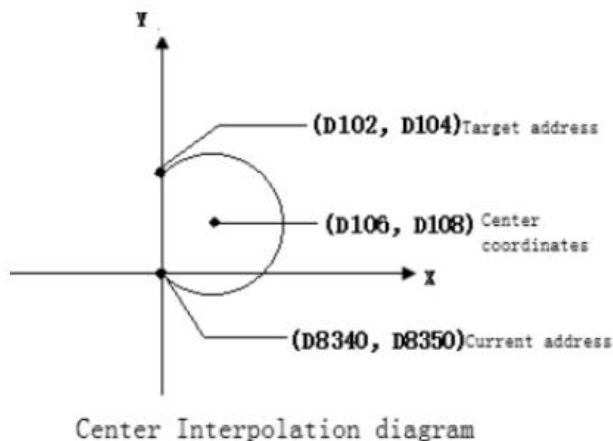

Note 1: The current address of X and Y must be on the same circle as the destination address.

Note 2: When the current address coincides with the target address, it indicates that the motion track is a full circle.

In the radius interpolation: D100 speed, D102 is the X-axis target address, D104 is the Y-axis target address, and D106 is the radius length. Y0 and Y1 respectively pulse the X-axis and Y-axis. (The example below is clockwise, i.e. M8435=0)

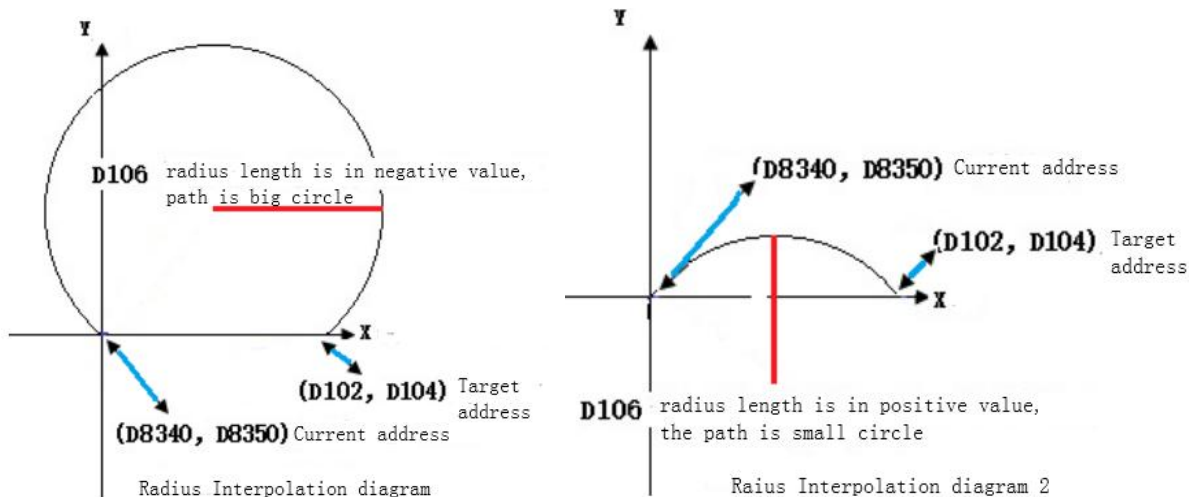

2.11.2.2 Continuous interpolation function

M8436 is the flag for the normal interpolation mode and continuous interpolation mode.

M8436=0: regular interpolation mode;

M8436=1: continuous interpolation mode;

Continuous interpolation motion uses DPLSR for pulse output.

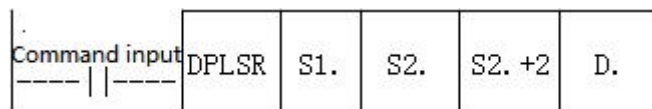

Operand Description: All use 32-bit registers.

S1. indicates the pulse frequency, that is, the speed of the interpolation motion.

S2. indicates the X-axis target address.

S2.+2 indicates the Y-axis target address.

In the center mode: S2.+4 and S2.+6 indicates the Center coordinates.

In radius mode: S2.+4 indicates the radius length, and S2.+6 ignores and unused.

S2.+4 positive value: the path is a small circle;

S2.+4 negative value: the path is a big circle.

S2.+8 is the control register.

D.: Specify the Y number with pulse output (Currently, only Y0 is supported, corresponding to direction Y4; Y1 is another axis, corresponding to direction Y5)

In continuous interpolation mode, M8432~M8435 are determined by the 5th parameter (ie S.+10).

The function description of each bit of the 32-bit register S2.+8 is as follows:

32bit position	b31~b28	b27~b24	b23~b20	b19~b16	b15~b12	b11~b8	b7~b4	b3~b0
Function	Continuous interpolation execution and stop Flag position					Position mode	Interpolation direction	Interpolation mode

When S2.+8 is used, it is expressed in **hexadecimal**. The bit values of each group are as below shown :

b3~b0	=1: linear mode interpolation =2: center mode interpolation =3: radius mode interpolation
b7~b4	=0: clockwise rotation =1: counterclockwise rotation = any other value: linear mode
b11~b8	=1: relative position =2: absolute position
b31~b12	=00000: continuous interpolation execution =AAAAA: continuous interpolation stop

PS: When using linear mode interpolation, b7~b4 is ignored and can be set to any value from 2~F.

S1. and S2. may be set discontinuous. For example, S1.=D100, S2.=D120.

S2. Must be consecutive with the next four 32-bit registers. For example, it must be set to D102, D104, D106, D108, D110.

For example: draw a line and two arcs, as shown below:

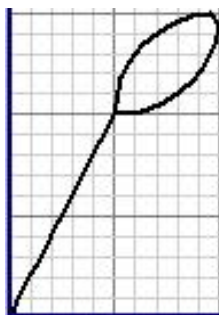

Program as below :

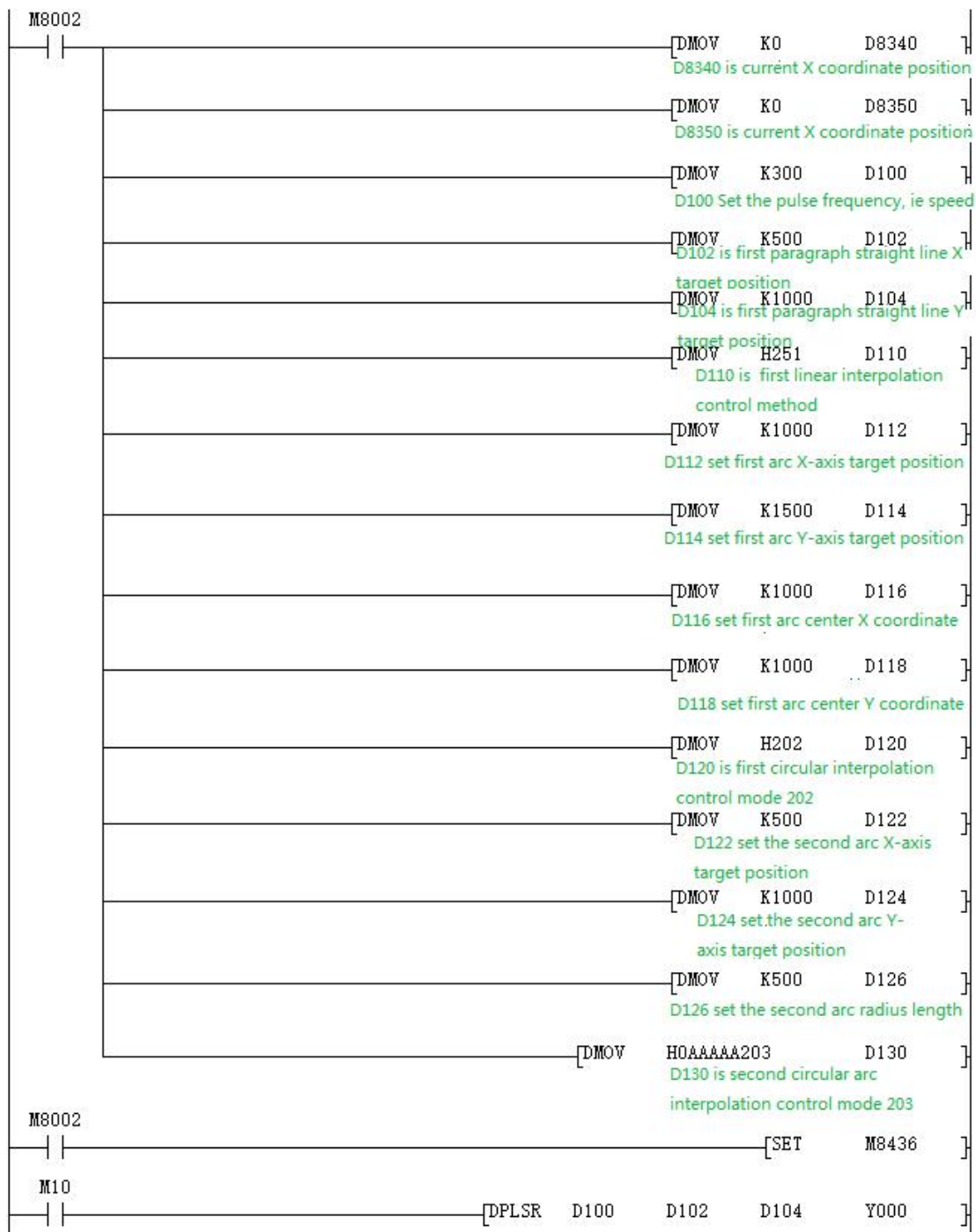

2.11.3 Pulse width modulation (PWM)

1) Outline

This instruction is used to specify the pulse period and pulse output of the ON time.

2) PWM instruction format and parameter description.

Instruction format:

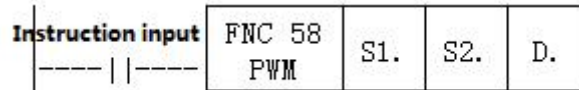

Parameter description:

Operand type	Content	Data type	Word software component	Range
S1.	Word soft component numbers of Pulse width (ms) data or saving data	BIN 16 bit	KnX, KnY, KnM, KnS, T, C, D, R, V, Z, K, H	0~32767ms
S2.	Word soft component numbers of Period (ms) data or saving data	BIN 16 bit	KnX, KnY, KnM, KnS, T, C, D, R, V, Z, K,H	1~32767ms
D.	Soft component (Y) numbers of Output pulse	BIN 16 bit	Y	Y0-Y3(5~100KHz) Y4-Y7(5~10KHz)

3) Function and action description

16-bit operation (PWM):Pulse output in units of period [S2.ms],Its ON pulse width is [S1.ms].

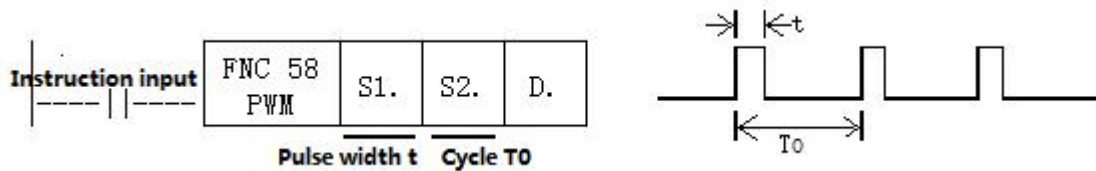

Notes.

Value of the pulse width S1. and the period S2. should be set: $S1. \leq S2.$

When instruction input is OFF, Output from D. is also OFF.

Do not operate the setting switch of the pulse output mode during pulse emission.

4) Program Example

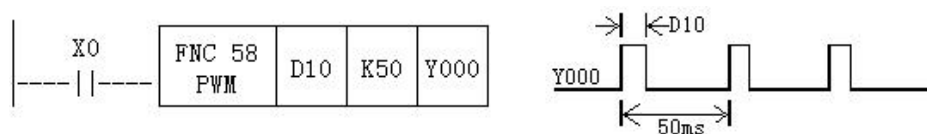

In this example, the data range of D10 is changed from 0 to 50, and the average output of Y0 is 0 to 100%. If D10 data >50, it will be wrong.

the special register and then turn on the hardware.

The special registers used for each analog, check below table:

Analog output address	DA0	DA1	DA2	DA3	DA4	DA5	DA6	DA7
Duty cycle setting	D8050	D8051	D8052	D8053	D8054	D8055	D8056	D8057
PWM frequency division coefficient setting (32 bits)	D8268	D8268	D8268	D8268	D8278	D8278	D8278	D8278

V26235-1 and later versions are used as follows:

D8050 to D8057: the corresponding duty cycle, the value range is 0~4000, each 1 is 0.025%, and the total corresponds to 0~100%;

D8268 and D8278: the value range is 1~100000Hz (32 bits);

D8050 to D8057 \cong D8268 and D8278

When D8268 and D8278 are powered on, the default setting is 21000Hz, and the power is not maintained. Program assignment is required when using.

2.11.4 Hand wheel pulse function

The hand wheel pulse generator is commonly known as the electronic hand wheel and hand wheel. It is mainly used for setting the teaching origin of the teaching CNC machine in the CNC machine tool, stepping fine-tuning in manual mode, and interrupting insertion during processing. Widely used in CNC engraving and milling machines, CNC milling machines, CNC lathes, machining centers, CNC wire cutting machine tools, CNC EDM machine tools, printing equipment, textile machinery and other fields.

Coolmay 3G series PLC supports the handwheel function (only supports the servo motor, does not support the stepper motor). With the cooperation of the 3G PLC, the handwheel is used to control the motor rotation, and the handwheel can rotate one pulse, and the motor also rotates the corresponding one. Number of pulses.

Special sign

M8228: Turn ON to enable the hand wheel function (the original C228 function is not used for now)

Instruction format and parameter description when using the hand wheel.

Instruction format

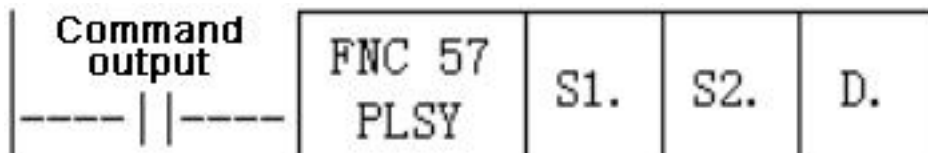

Parameter Description:

Operand type	content	type of data	Word software
S1.	Set the numerator of the input to output ratio	BIN16 digits	K,D
S2.	Set the denominator of the input to output ratio	BIN16 digits	K,D
D.	Output pulse device (Y) number	BIN16 digits	pulse: Y0-Y5 Corresponding direction: Y10-Y15

PS: When setting S1. and S2., S1. must be an integer multiple of S2. If it is 1:1, it means that the hand wheel rotates one pulse and the motor rotates one pulse; if it is an integer multiple of n, it means that the hand wheel rotates one pulse and the motor rotates n pulses;

The hand wheel connection is shown below:

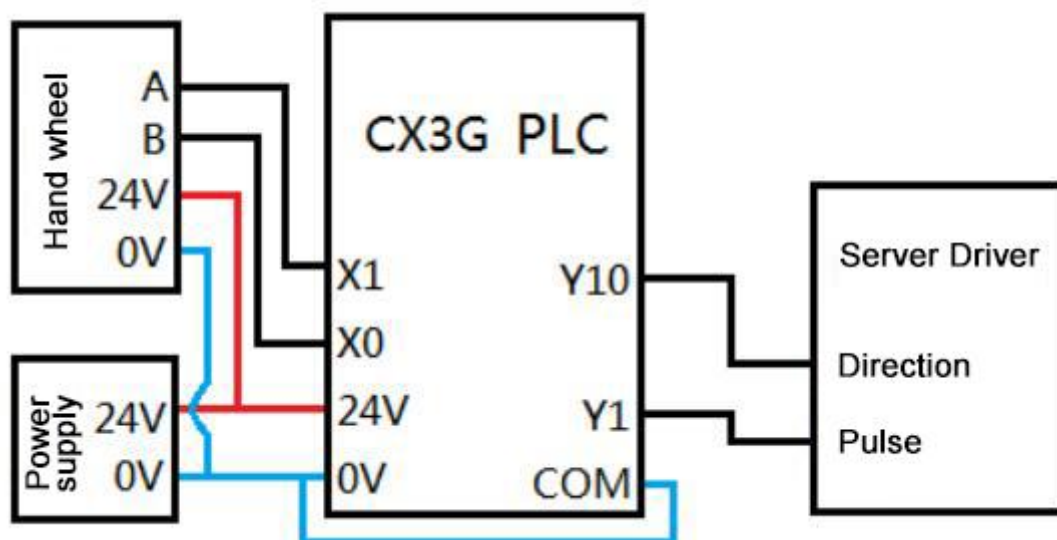

The hand wheel function program is shown below:

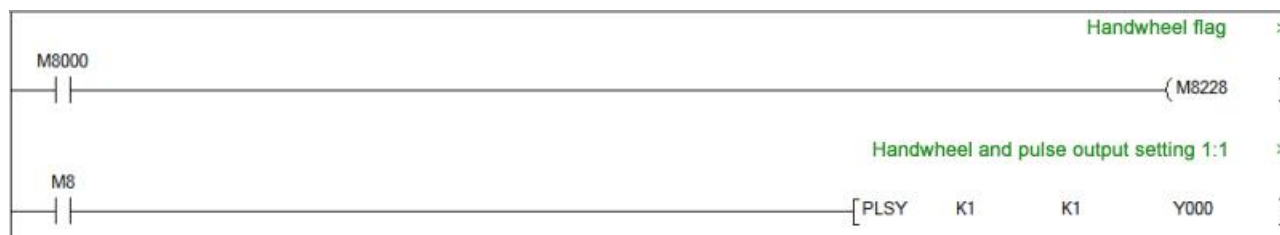

This program is 1:1 pulse output, that is, how many the hand wheel rotates, then how many pulse Y0 will output.

2.12 PLC Communication port instructions

PLC defaulted has a RS232 programming port, and two communication ports (Rs232 or Rs485) can be added. Meanwhile, CANbus is also optional.

2.12.1 MODBUS instruction interpretation and communication address

PLC, when as master, support ADPRW command, RD3A command, WR3A command, this section will give you detailed description about these commands.

2.12.1.1 RD3A/WR3A command function and action description:

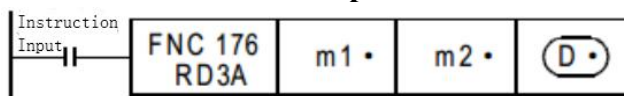

Read slave data (RD3A):

For CoolMay PLC, the RD3A instruction corresponds to Modbus's No. 03 function.

m1 represents the station number of the read slave device, range: 1-247;

m2 represents the first address number of the read data in the slave device;

D represents the number of registers read, range: 1-125(When Modbus ASCII, range is 1-45; When CAN communication, range is 1-90), and the read data is sequentially stored in the host D.+1, D.+2.

D-1 address value must be set to (=0: serial port 2; =1: serial port 3; =2: CAN; =3: Modbus TCP/IP)

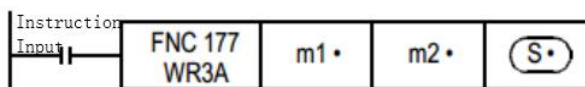

Write data to the slave (WR3A):

WR3A originally referred to the analog modules write.

For CoolMay PLC, the WR3A instruction corresponds to Modbus's 06 and 10 functions.

m1 represents the station number of the slave device to be written, range :1-247.

m2 represents the first address number of the write register in the slave device;

S represents the numbers of registers to be written, ranging: 1-123(When Modbus ASCII, range is 1-45; When CAN communication, range is 1-90). The data to be written is sequentially stored in the host S.+1, S.+2.

S=1, the WR3A instruction corresponds to the Modbus 06 function.

S=2-123, the WR3A instruction corresponds to the Modbus 10 function.

S.-1 address value must be set to (=0: serial port 2; =1: serial port 3; =2: CAN; =3: Modbus TCP/IP)

RD3A and WR3A only support the below MODBUS functions:

Function No. 03: Read holding register and takes the current binary value range of 1-125 in one or more holding registers.

Function No. 06: Load the specific binary value into a holding register (write register) ,range:1.

Function No. 10: Preset multiple registers, load specific binary values into a series of consecutive holding registers (write multiple registers),range:1-123.

2.12.1.2 ADPRW command function and action description:

ADPRW instruction supports all functions of the MODBUS RTU.

No. 01: Read coil status and get the current status (ON/OFF) of a group of logic coils, range 1-512

No. 02: Read the input status and get the current status (ON/OFF) of a group of switch inputs, range 1-512

No. 03: Read the retentive register and get the current binary value in one or more retentive registers, ranging from 1-125

No. 04: Get the current binary value in one or more input registers, range 1-125

No. 05: Force a single coil to force the on/off state (write bit) of a logic coil, range 1

No. 06: Load specific binary values into a retentive register (write register), range 1

No. 0F: Force multiple coils, forcibly open and close a series of continuous logic coils (write multiple bits), range 1-1968

No. 10: Preset multiple registers, load specific binary values into a series of consecutive holding registers (write multiple registers). Range 1-125

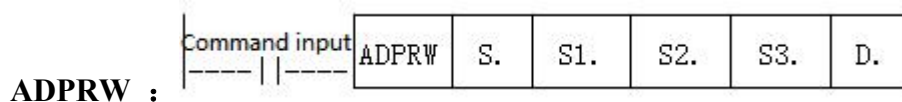

S. indicates the station number of the slave device to be read and written, the range is 0-247;

S1. indicates the function code (that is, the functions NO 01-06, 15, and 16);

S2. The function parameter corresponding to each function code (the operand indicates the MODBUS start address when the function is 01);

S3. The function parameters corresponding to each function code (the operand indicates the number of access points when the function is 01, and the parameter is fixed to 0 when the 05 function is used);

D. indicates the starting position of the data storage device.

2.12.1.3 Word device Communication address number

MODBUS device		EX3G device
Input register (readout dedicated)	Holding register (read/write)	
-	0x0000~0x1F3F	D0~D7999
-	0x1F40~0x213F	D8000~D8511
-	0x2140~0x7EFF	R0~R23999
-	0x7F00~0xA13F	Unused address
-	0xA140~0xA27F	TN0~TN319

-	0xA280~0xA33F	Unused address
-	0xA340~0xA407	CN0~CN199
-	0xA408~0xA477	CN200~CN255
-	0xA478~0xA657	M0~M7679
-	0xA658~0xA677	M8000~M8511
-	0xA678~0xA777	S0~S4095
-	0xA778~0xA78B	TS0~TS319
-	0xA78C~0xA797	Unused address
-	0xA798~0xA7A7	CS0~CS255
-	0xA7A8~0xA7AF	Y0~Y177
0xA7B0~0xA7B7	-	Unused address
0xA7B8~0xA7BF	-	X0~X177
An error occurs when accessing an unused address CN200~255 is a 32-bit counter		

2.12.1.4 Bit device Communication address number

MODBUS device		EX3G device
Input (readout dedicated)	Coil (read/write)	
-	0x0000~0x1DFF	M0~M7679
-	0x1E00~0x1FFF	M8000~M8511
-	0x2000~0x2FFF	S0~S4095
-	0x3000~0x313F	TS0~TS319
-	0x3140~0x31FF	Unused address
-	0x3200~0x32FF	CS0~CS255
-	0x3300~0x337F	Y0~Y177
0x3380~0x33FF	-	Unused address
0x3400~0x347F	-	X0~X177
An error occurs when accessing an unused address CN200~255 is a 32-bit counter		

2.12.1.5 ADPRW Command function parameter

Operand function	S1. Function code	S2. MODBUS address/subfunction code	S3. Access points/subfunction data	D. Data storage device start
Coil readout	1H	MODBUS Address: 0000H~FFFFH	Access points: 1~2000	Read object device D.R.M.Y.S
Input readout	2H	MODBUS Address: 0000H~FFFFH	Access points: 1~2000	Read object device D.R.M.Y.S
Holding register readout	3H	MODBUS Address: 0000H~FFFFH	Access points: 1~125	Read object device D.R
Input register readout	4H	MODBUS Address: 0000H~FFFFH	Access points: 1~125	Read object device D.R

Single coil write	5H	MODBUS Address: 0000H~FFFFH	0(Fix)	Write object device D.R.X.Y.M.S 0=OFF 1=ON
Single register write	6H	MODBUS Address: 0000H~FFFFH	0(Fix)	Write object device D.R
Bulk coil writing	FH	MODBUS Address: 0000H~FFFFH	Access points: 1~1968	Write object device D.R.X.Y.M.S
Bulk register write	10H	MODBUS Address: 0000H~FFFFH	Access points: 1~123	Write object device D.R

2.12.2 Serial port 2: RS485(A B)

Support MITSUBISHI programming port protocol, Mitsubishi BD board protocol, Free port protocol and MODBUS RTU protocol;

The special relays and registers related to this serial port are as below:

Functions	Serial port 2(A/B)	Serial port 3(A1/B1)	CAN(H/L)	Remark
Mitsubishi programming port protocol	M8196=0	M8192=0	-	Power outage not maintained
Freeport protocol function	M8196=1 M8125=0	M8192=1	-	
RS/RS2 sending mark	M8122=1	M8402=1	M8422=1	
RS/RS2 sending completion mark	-	-	M8425	Need to reset manually
RS/RS2 receiving completion mark	M8123	M8403	M8423	Need to reset manually
RS/RS2 receiving process mark	M8124	M8404	M8424	Data is receiving
RS/RS2 command 8/16 bits differentiation mark	M8161	M8161	M8161	
RS command CAN master-slave mark	-	-	M8426	M8426=0 master-slave mode, M8426=1 multi-device mode
RS2 command end operation settings	-	1	2	
MODBUS function	M8196=1 M8125=1	M8192=1	-	
RD3A/WR3A Receive correct mark	M8128	M8408	M8428	Automatic reset
RD3A\WR3A communication over-time mark	M8129	M8409	M8429	Automatic reset
ADPRW command completion mark	M8029	M8029	M8029	Command execution end mark
Communication parameters	D8120	D8400	D8420	
Communication mode	-	D8401	D8421	
Master-slave station number	D8121	D8414	D8434 D8440	D8434: CAN slave station NO D8440/D8442: multi-device mode ID

			D8442	NO
RD3A/WR3A overtime	D8129	D8409	D8429	Unit: ms (detailed setting, refer to explanation)
RD3A/WR3A interval period	D8126	D8406	D8426	
RD3A\WR3A end operation -1	0	1	2	
ADPRW command settings	D8397=0	D8397=1	D8397=2	
CAN data frame	-	-	M8427	

M8196: the activation flag of using programming port protocol and other protocol.

M8125: the activation flag of using MODBUS and the original Mitsubishi function.

M8122: RS sending flag (this bit needs to be set 1 when using the RS instruction, and it will automatically reset after sending).

M8123: RS receiving completion flag (need to reset manually).

M8124: RS command data is being received.

M8161: 8-bit/16-bit mode flag of RS instruction (used in 26230 and above versions, fixed 8-bit mode in 26210/26220 version)

M8128: RD3A / WR3A receive the correct flag.

M8129: RD3A/WR3A communication over-time flag. (when communication is over-time, flag is ON)

M8029: Communication completion flag (communication completion flag when using ADPRW instruction, need to reset manually).

D8120: Save the communication parameters of the Modbus RTU protocol, and the highest bit of the communication parameters must be set to E.

D8121: Save the host or slave station number.

D8129: RD3A and WR3A timeout period.

D8126: Interval period. Default as 10 times.

D8397: When using the serial port 2 in the ADPRW instruction, set D8397 to 0.

Support RS, WR3A, RD3A, ADPRW instructions. Can be set in the parameter zone, corresponding to serial port 2. The parameter zone settings are only valid for this channel. It is invalid for serial port 3.

2.12.2.1 Mitsubishi programming port protocol

When used as programming port protocol: set M8196=0.

2.12.2.2 Free port protocol function and example

When used as a Mitsubishi free port protocol function: set M8196=1 and M8125=0;

The difference between Mitsubishi Protocol 1 and Protocol 4 is that they have the terminator 0A 0D (stored in D8124 and D8125 respectively)

When using the Mitsubishi free port protocol, RS instructions are supported, and D8120 only needs to set the value of the lower 8 bits.

b7	b6	b5	b4	b3	b2	b1	b0
----	----	----	----	----	----	----	----

b0	Data length 0:7 bits 1:8bits		
b1	Odd and Even (b2,b1)		
b2	00: None	01: Odd	02: Even
b3	Stop bit 0: 1 bit 1: 2 bits		
b4	BPS rate (b7,b6,b5,b4)		
b5	(0100):600bps	(0101):1200bps	(0110):2400bps
b6	(0111):4800bps	(1000):9600bps	(1001):19200bps
b7	(1010):38400bps	(1011):57600bps	(1101):115200bps

Demo program:

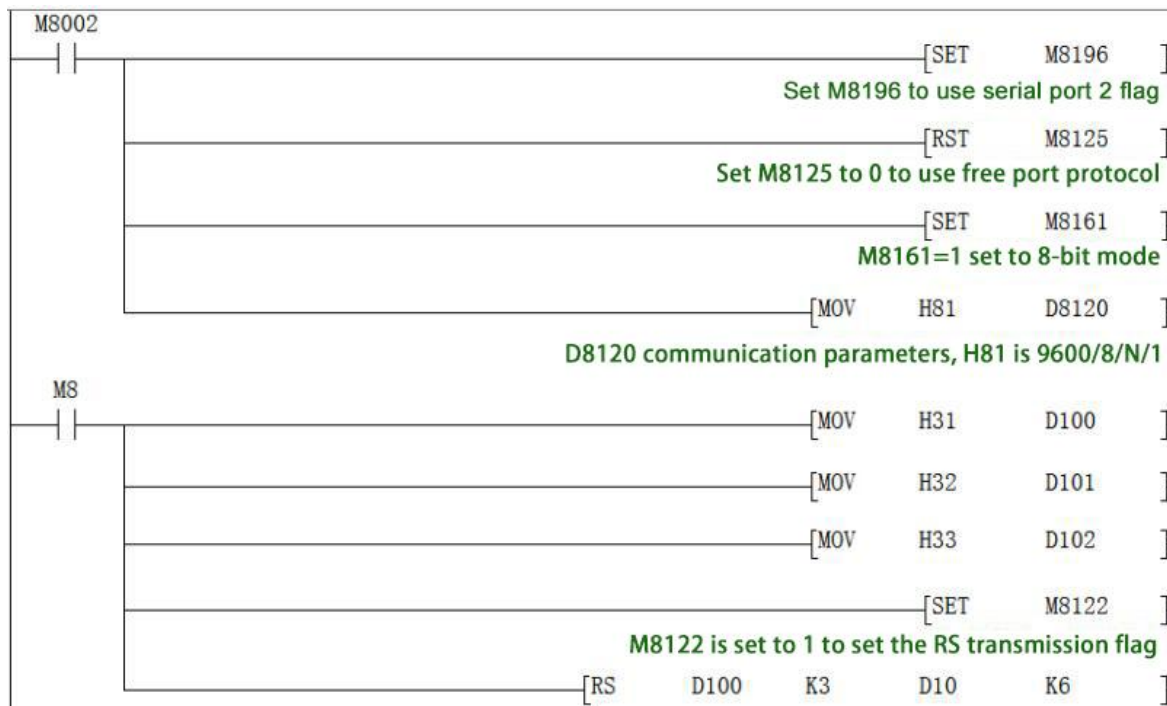

Use the serial port tool by serial port 2 to monitor the data obtained is
[2017:11:01:10:49:16][receive]31 32 33

2.12.2.3 Modbus RTU Protocol

When used as MOdbus RTU: set M8196=1,M8125=1; set D8120 as communication parameters, D8121 set as slave station. For example: D8120=HE081,D8121=H1(communications parameter as 9600/8/n/1,station number is 1)

D8120 Parameter set

b15	b14	b13	b12	b11	b10	b9	b8	b7	b6	b5	b4	b3	b2	b1	b0
-----	-----	-----	-----	-----	-----	----	----	----	----	----	----	----	----	----	----

b0	Data length 0:7 bit 1:8 bit
----	-----------------------------------

b1	Parity (b2,b1) 00:None 01:Odd 11:Even
b2	
b3	Stop bit 0:1 bit 1:2 bit
b4	Baud rate (b7 b6 b5 b4) (0111):4800bps (1000):9600bps (1001):19200bps (1010):38400bps (1011):57600bps (1101):115200bps
b5	
b6	
b7	
b8	Set 0
b9	
b10	
b11	
b12	RTU/ASCII Mode Selection 0:RTU 1:ASCII
b13	Set 1
b14	Set 1
b15	Set 1

RD3A Program example (refer to 2.11.1.1):

Slave program:

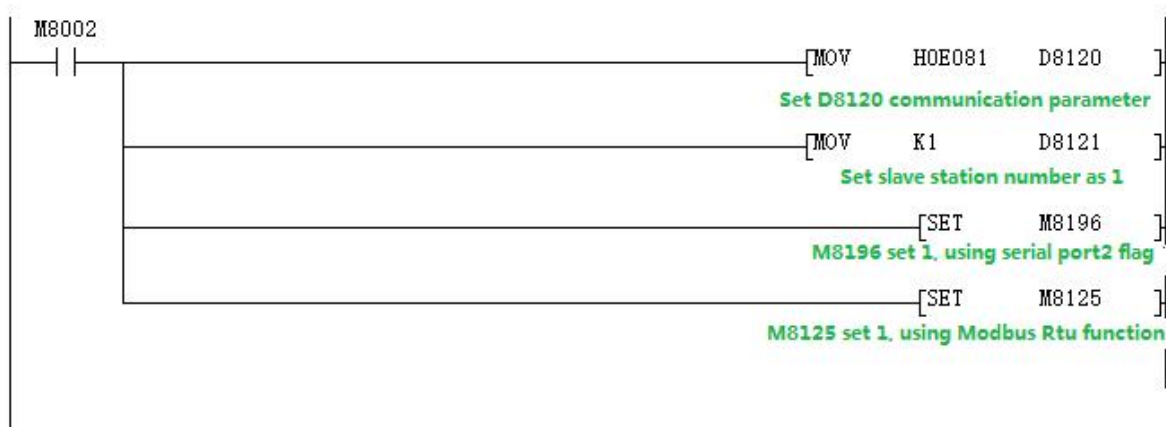

Master program:



Program explanation:

D300 saves the numbers of registers read, which means that 10 data is read.

D299 must be set to 0.

This program represents that 10 data of the registers D100-D109 in the PLC with the slave station 1 are read and stored in the registers D301-D310 of the master station PLC.

Use the serial port tool to monitor the results:

[2017:07:05:17:41:20][receive]01 03 00 64 00 0A 84 12

[2017:07:05:17:41:20][receive]01 03 14 00 6F 00 DE 01 4D 01 BC 02 2B 02 9A 03 09 03 78 03 E7 00 00 7D 69

(This example sets the data of the slave D100-D109 to 111-999).

WR3A Program example (refer to 2.11.1.1):

Slave program:

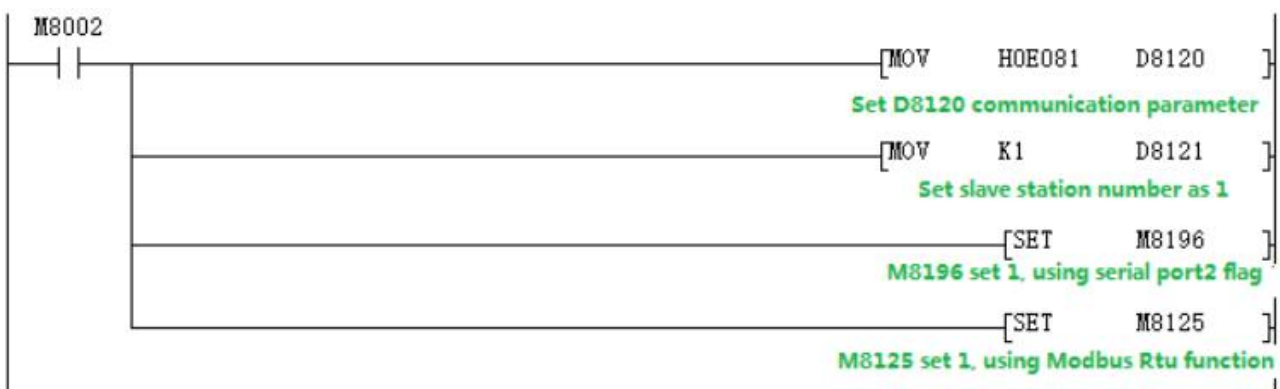

Master program:

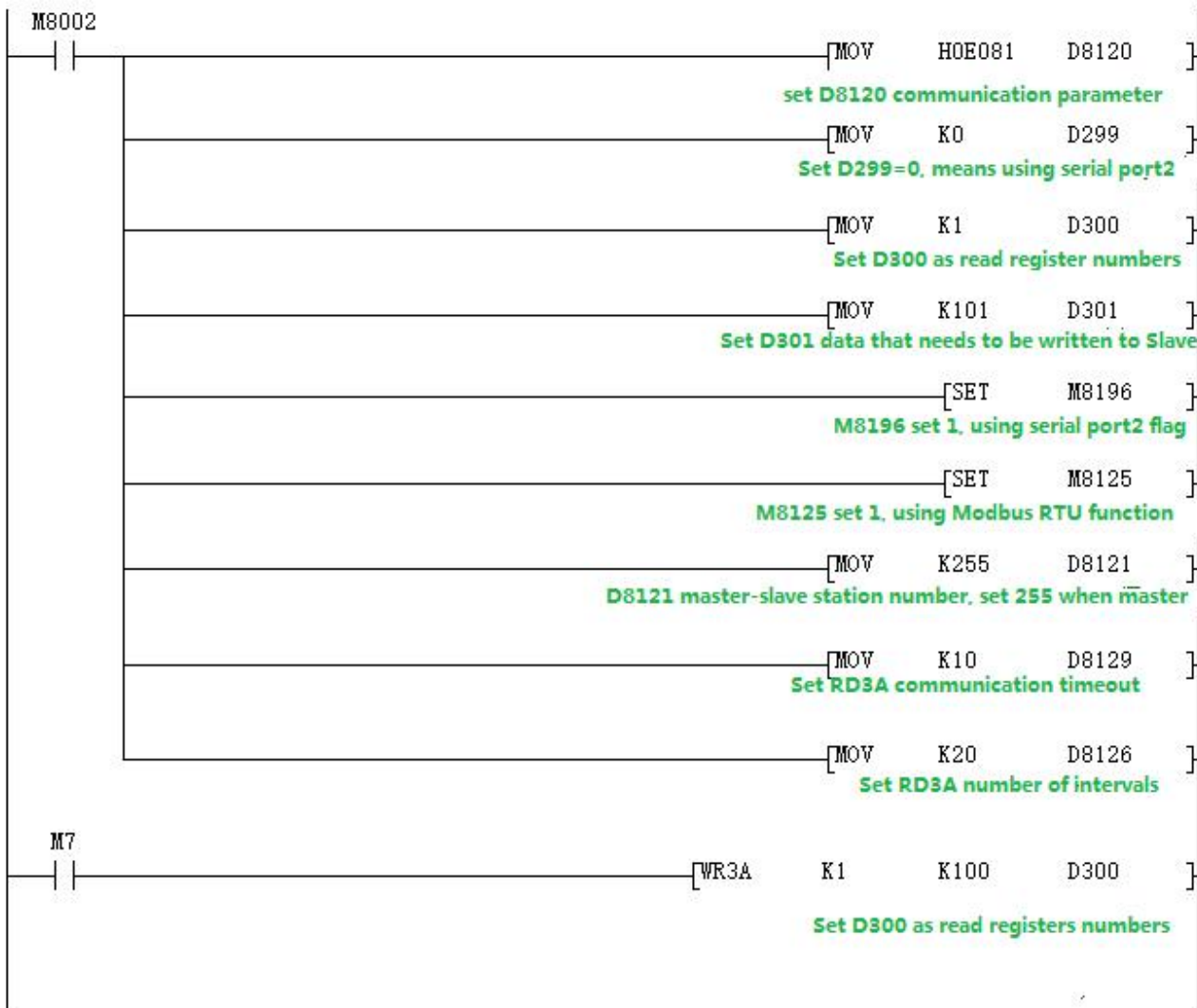

Program explanation:

This program represents that 1 data of the register D301 in the master PLC is written to the PLC in Slave 1, and is stored in the register D100 of the slave PLC.

Use the serial port tool to monitor the results:

[2017:10:31:16:47:22][receive]01 06 00 64 00 6F 88 39
 [2017:10:31:16:47:22][receive]01 06 00 64 00 6F 88 39

2.12.2.4 MODBUS RTU ADPRW command

03 function code hold register output. (refer to **2.11.1.2**):

Master program:

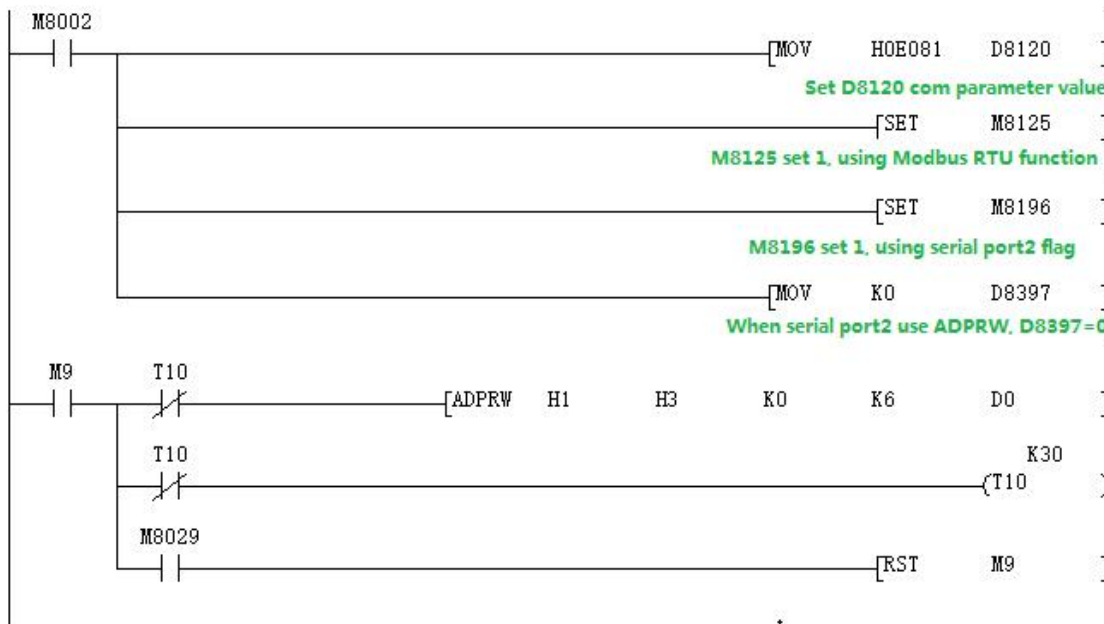

Slave program:

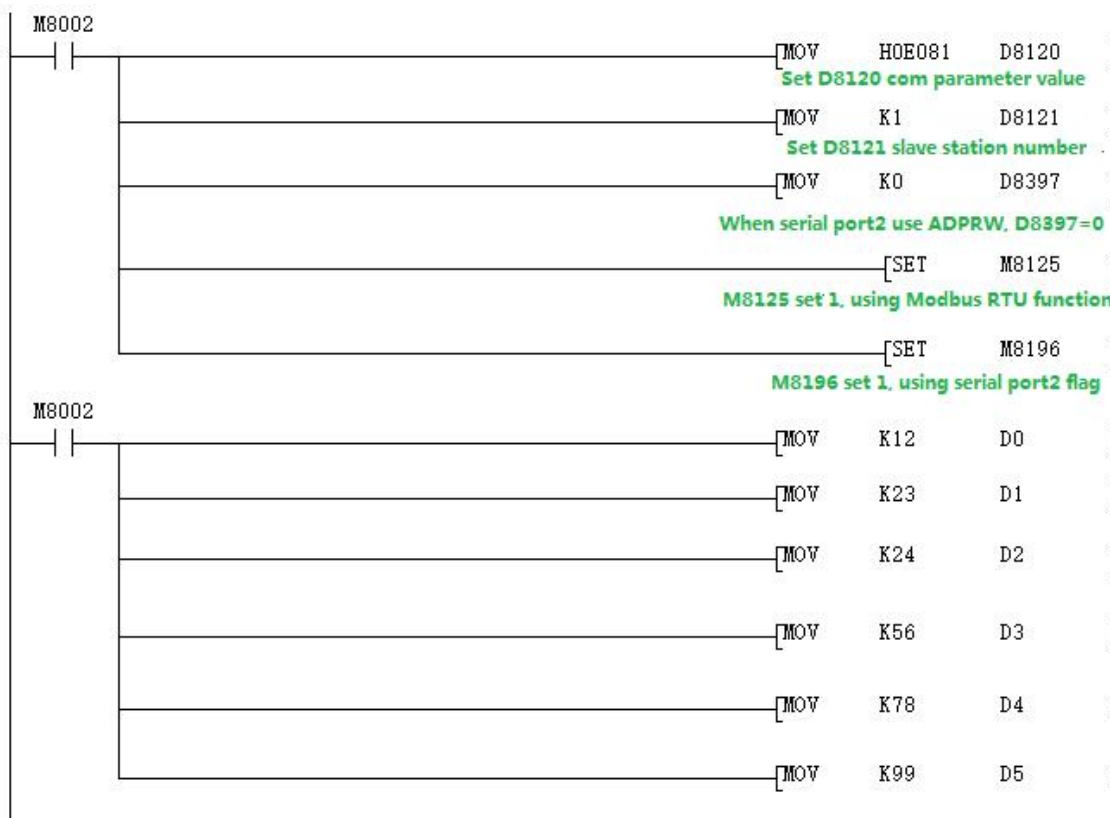

Use the serial port tool to monitor serial port 2 for below data:

[2017:11:01:17:48:54][receive]01 03 00 00 00 06 C5 C8

[2017:11:01:17:48:54][receive]01 03 0C 00 0C 00 17 00 22 00 38 00 4E 00 63 C4 29

2.12.2.5 Modbus ASCII Protocol

When used as Modbus ASCII protocol, specific parameter setting pls refer 2. 11. 2. 3, Only the 12th bit of D8120 is set differently, checking D8120 parameter setting in section 2. 11. 2. 3.

Note: In modbus ASCII protocol, ADPRW command is not supported.

Program example

Master program:



Slave program:

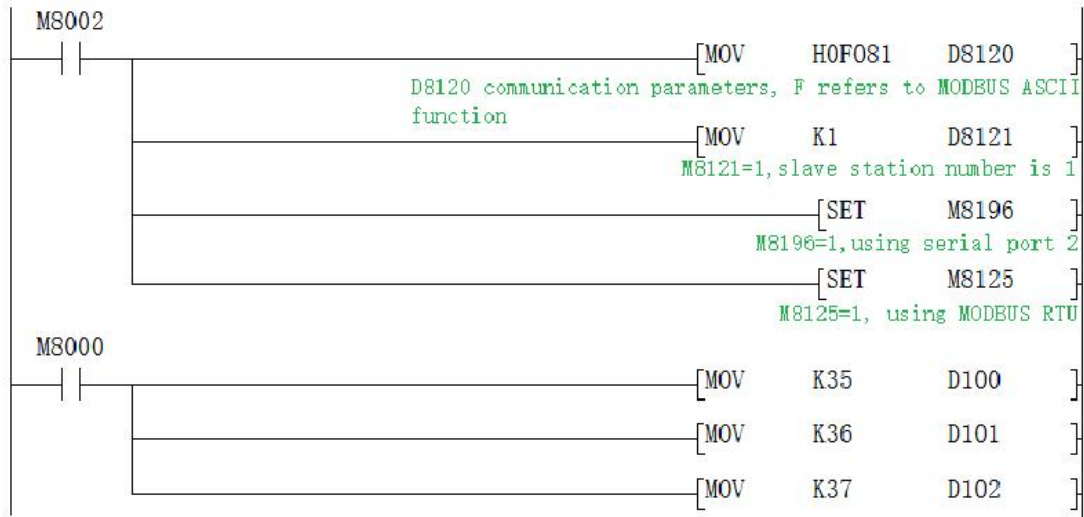

Data of the Master D300~D303 before and after the program execution is showed as below.

Soft components	+F E D C	+B A 9 8	+7 6 5 4	+3 2 1 0	
D300	0 0 0 0	0 0 0 0	0 0 0 0	0 0 1 1	3
D301	0 0 0 0	0 0 0 0	0 0 0 0	0 0 0 0	0
D302	0 0 0 0	0 0 0 0	0 0 0 0	0 0 0 0	0
D303	0 0 0 0	0 0 0 0	0 0 0 0	0 0 0 0	0

Monitor D300-D301 data before the master M7 turns on.

Soft components	+F E D C	+B A 9 8	+7 6 5 4	+3 2 1 0	
D300	0 0 0 0	0 0 0 0	0 0 0 0	0 0 1 1	3
D301	0 0 0 0	0 0 0 0	0 0 1 0	0 0 1 1	35
D302	0 0 0 0	0 0 0 0	0 0 1 0	0 1 0 0	36
D303	0 0 0 0	0 0 0 0	0 0 1 0	0 1 0 1	37
D304	0 0 0 0	0 0 0 0	0 0 0 0	0 0 0 0	0

Monitor D300-D301 data after the master M7 turns on.

2.12.3 Serial port 3:RS485 (A1 B1)/RS232

Support Mitsubishi programming port protocol,RS2 protocol and MODBUS protocol.

The special relays and registers related to this serial port are as below.

Functions	Serial port 2(A/B)	Serial port 3(A1/B1)	CAN(H/L)	Remark
Mitsubishi programming port	M8196=0	M8192=0	-	Power outage not maintained
Freeport protocol function	M8196=1 M8125=0	M8192=1	-	
RS/RS2 sending mark	M8122=1	M8402=1	M8422=1	
RS/RS2 sending completion mark	-	-	M8425	Need to reset manually
RS/RS2 receiving completion mark	M8123	M8403	M8423	Need to reset manually
RS/RS2 receiving process mark	M8124	M8404	M8424	Data is receiving
RS/RS2 command 8/16 bits differentiation mark	M8161	M8161	M8161	
RS2 command CAN master-slave mark	-	-	M8426	M8426=0 master-slave mode, M8426=1 multi-device mode
RS2 command end operation settings	-	1	2	
MODBUS function	M8196=1 M8125=1	M8192=1	-	
RD3A\WR3A Receive correct mark	M8128	M8408	M8428	Automatic reset
RD3A\WR3A communication over-time mark	M8129	M8409	M8429	Automatic reset
ADPRW command completion mark	M8029	M8029	M8029	Command execution end mark
Communication parameters	D8120	D8400	D8420	
Communication mode	-	D8401	D8421	
Master-slave station number	D8121	D8414	D8434 D8440 D8442	D8434:CAN slave station Number D8440\D8442 multi-device mode ID Number
RD3A\WR3A overtime	D8129	D8409	D8429	Unit: ms (detailed setting, refer to explanation)

RD3A/WR3A interval period	D8126	D8406	D8426	26232 or higher version
RD3A/WR3A end operation -1	0	1	2	
ADPRW command settings	D8397=0	D8397=1	D8397=2	
CAN data frame	-	-	M8427	

M8192: the activation flag of using programming port protocol and other protocol .

M8402: Send flag (use when RS2 instruction)。

M8403: Communication completion flag (communication completion flag when using RS instruction, needs to be reset by hand).

M8404: Data is receiving.

M8408: Communication completion mark (Valid while using ADPRW command and needs manual reset).

M8409: Communication time out.

M8029: Communication completion mark (communication completion mark while using ADPRW instruction and needs manual reset).

M8161: 8-bit/16-bit mode distinguishing mark for RS/RS2 command .

D8400: Save the communication parameters of the Modbus RTU protocol

D8401: Save the communication mode of serial port 3.

D8401=H0 represents the RS free communication mode.

When Modbus RTU: D8401=H11 represents PLC as Slave. D8401=H1 represents PLC as Master.

When Modbus ASCII: D8401=H111 represents PLC as Slave; D8401=H101 represents PLC as Master.

D8406: Interval period. Default as 12 times.

D8409: overtime time. **(The unit is milliseconds, it is recommended to set: when the communication rate is greater than or equal to 9600, D8409 is set to 10~20; when the communication rate is set to less than 9600, D8409 is set to 20~50;)**

D8414: Save the master or slave station number (The value must be set as max K255 as master).

D8397: When using the serial port 3 in the ADPRW instruction, set D8397 to 1.

Supports RS2, WR3A, RD3A, and ADPRW instructions. It can be set in the parameter area, which is only valid for serial port 3. Invalid for serial port 2.

D8400 Parameter set

Bit number	Content
b0	Data length 0:7 bit 1:8 bit
b1 b2	Parity (b2,b1) 00:None 01:Odd 11:Even
b3	Stop bit 0:1 bit 1:2 bit

b4	Baud rate (b7 b6 b5 b4) 0111:4800bps 1000:9600bps 1001:19200bps 1010:38400bps 1011:57600bps 1100:Not used 1101:115200bps
b5	
b6	
b7	
b8-b15	Unavailable, Set 0

D8401 Parameter set

b0	Select protocol 0: Other communication protocol 1: MODBUS protocol
b1~b3	Unavailable, Set 0
b4	Master/Slave setting 0: MODBUS Master 1: MODBUS Slave
b5~b7	Unavailable, Set 0
b8	RTU/ASCII Mode selection 0:RTU 1:ASCII
b9~b15	Unavailable, Set 0

2.12.3.1 Mitsubishi programming protocol

When using as mitsubishi programming port protocol: set M8192=0.

2.12.3.2 Mitsubishi BD Protocol

When used as the Mitsubishi BD protocol function: set M8196=1, M8125=0; D8120 is set as the communication parameter, and D8121 is set as the slave station number. For example, set D8120=H6086, D8121=H1 (communication parameter is 9600/7/E/1, slave station number is 1).

D8120 parameter setting

b15	b14	b13	b12	b11	b10	b9	b8	b7	b6	b5	b4	b3	b2	b1	b0
-----	-----	-----	-----	-----	-----	----	----	----	----	----	----	----	----	----	----

b0	Data length 0: 7 bits 1: 8 bits
b1	Parity (b2,b1)
b2	00: None; 01: Odd; 11: Even

b3	Stop bit 0:1 bit 1: 2 bits
b4	Baud rate (b7,b6,b5,b4)
b5	(0100):600bps (0101):1200bps (0110):2400bps
b6	(0111):4800bps (1000):9600bps (1001):19200bps
b7	(1010):38400bps (1011):57600bps (1101):115200bps
b8	Set 0
b9	
b10	
b11	
b12	Set 0
b13	Set 1
b14	Set 1
b15	Set 0

Example of PLC as slave program:



HMI can communicate with PLC by setting BD protocol master station.

2.12.3.3 Free port protocol

When using as mitsubishi free port protocol: set M8192=1, M8402=1;

Program example:

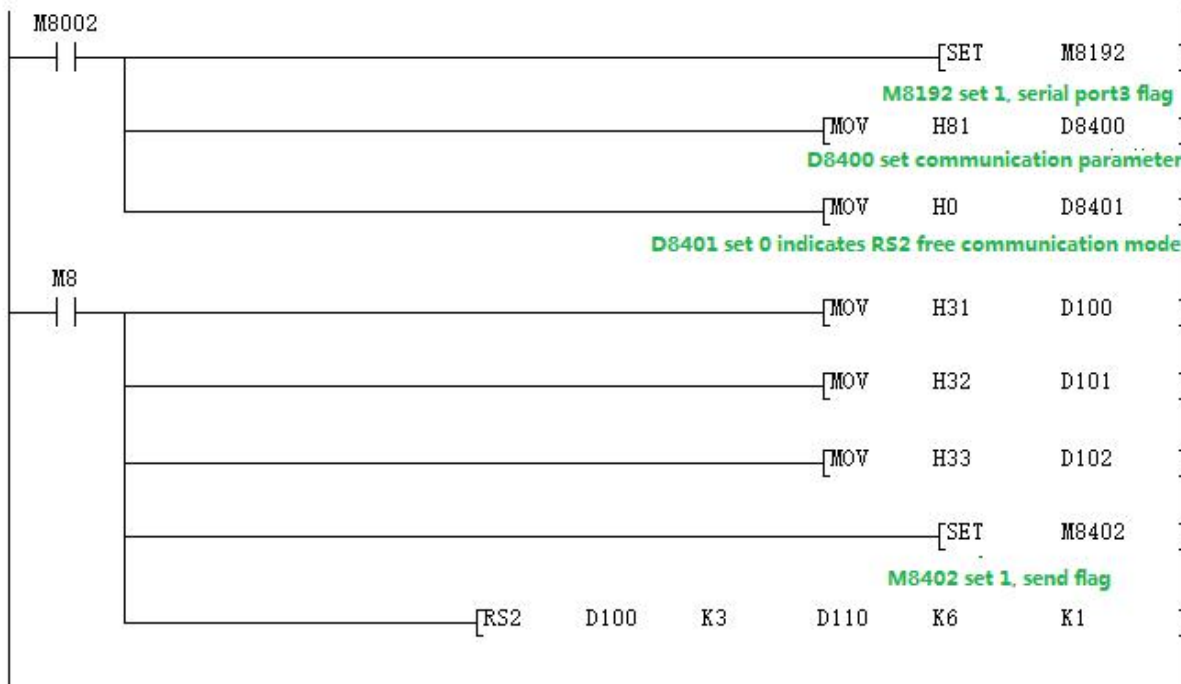

Use the serial port tool to monitor serial port 3 for data:[2017:11:01:11:49:16][receive]31 32 33
 Last parameter of RS2 instruction =1: Serial port 3;
 =2: CAN.

2.12.3.4 Modbus RTU protocol RD3A/WR3A command

Used as MODbus RTU: set M8192=1; set D8400 as communication parameters, set D8414 s as master slave station no. For example: D8400=H81, D414=K1 (communications parameter as 9600/8/n/1,slave station number is 1)

RD3A Program Example (Refer to 2.11.1.1):

Slave program:



Master program:



Use the serial port tool to monitor serial port 3 for below data:

[2017:11:01:09:00:11][receive]01 03 00 64 00 0A 84 12

[2017:11:01:09:00:11][receive]01 03 14 00 42 00 4D 00 58 00 58 00 63 00 37 00 2C 00 21 00 16 00 0B 9F C7

WR3A Program Example (Refer to 2.11.1.1):

Slave program

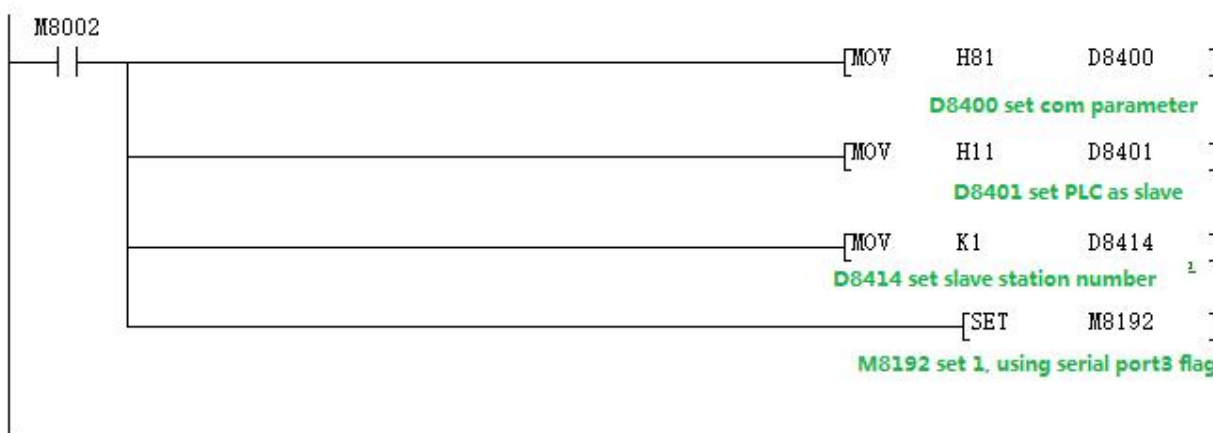

Master program

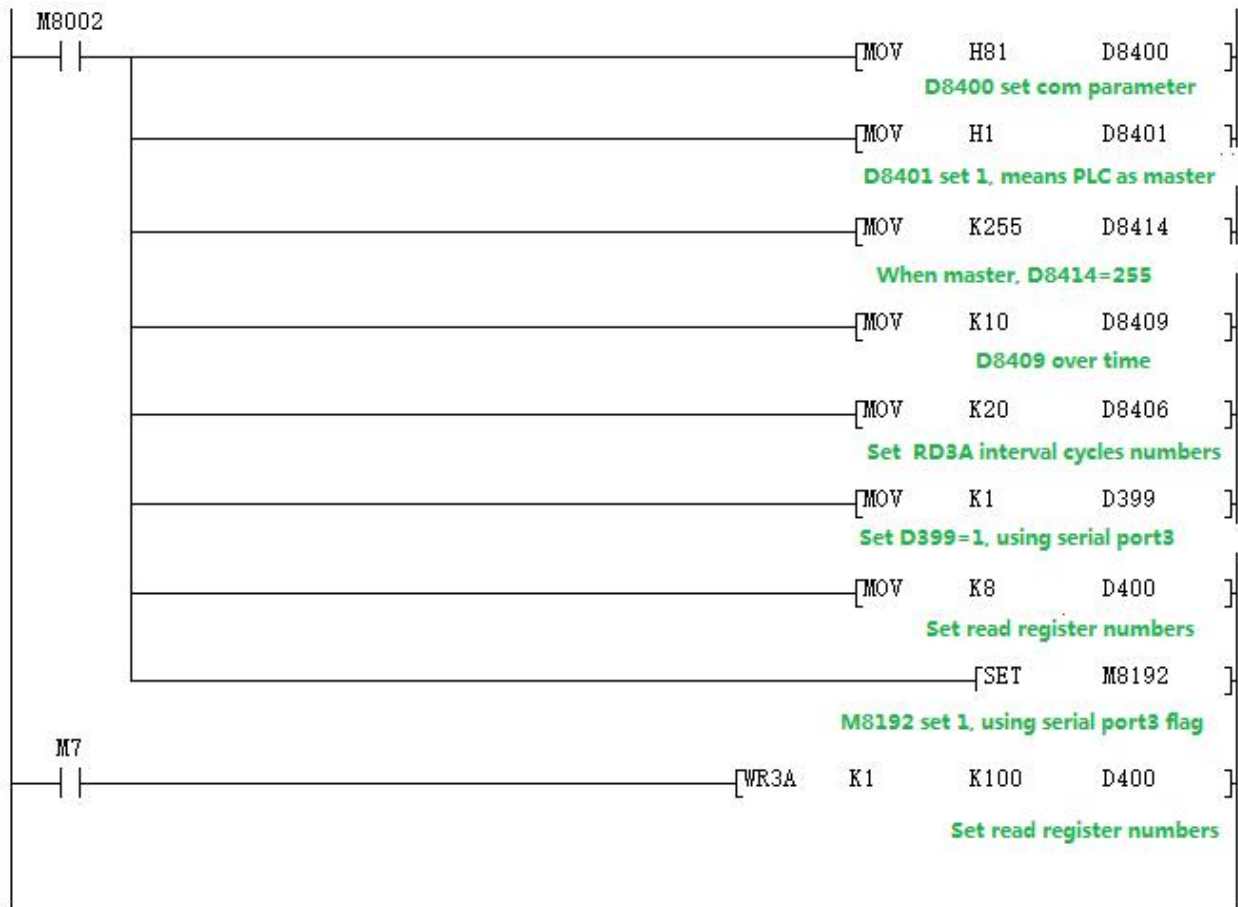

Use the serial port tool to monitor serial port 3 for below data:

[2017:11:01:25:20][receive]01 10 00 64 00 08 10 00 0B 00 16 00 21 00 2C 00 37 00 42 00 4D 00 58 D1 6C

[2017:11:01:09:25:20][receive]01 10 00 64 00 08 10 00 0B 00 16 00 21 00 2C 00 37 00 42 00 4D 00 58 D1 6C

2.12.3.5 MODBUS RTU ADPRW Command

04 register input readout. **Program Example (Refer to 2.11.1.2):**

Master program

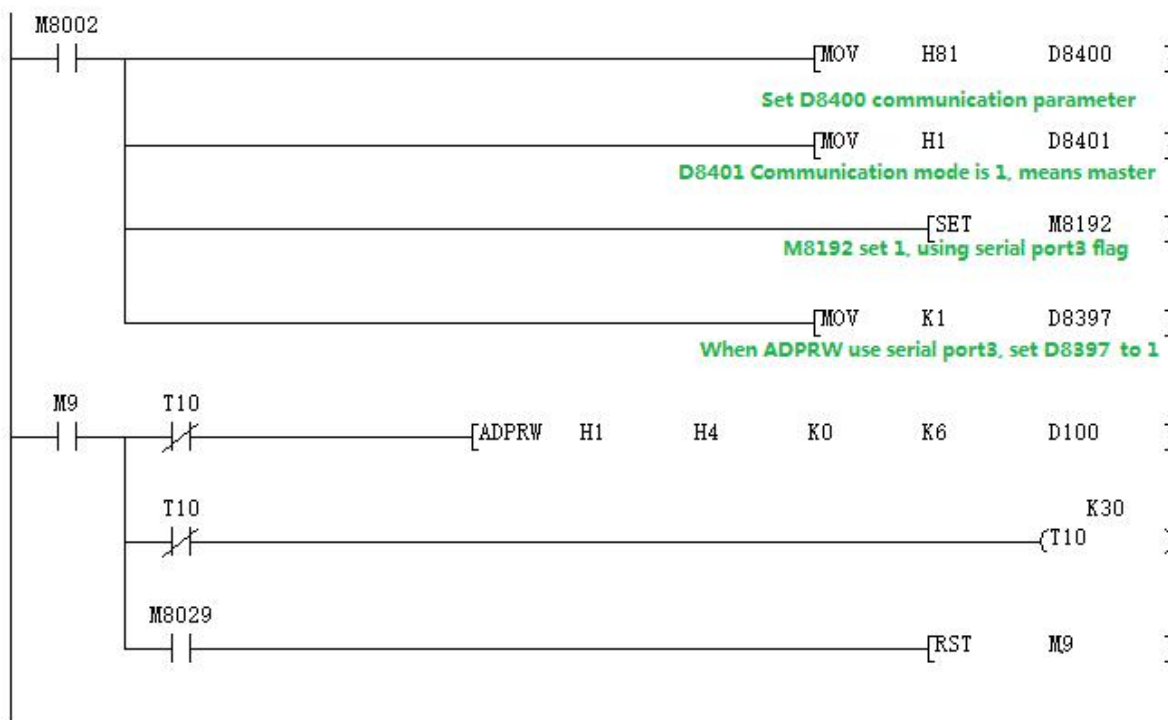

Slave program



Use the serial port tool to monitor serial port 3 for below data:

[2017:11:01:17:38:34][receive]01 04 00 00 00 06 70 08

[2017:11:01:17:38:34][receive]01 04 0C 00 15 00 20 00 2B 00 41 00 57 00 00 5F A7

2.12.3.6 Modbus ASCII Function

When used as Modbus ASCII protocol, specific parameter setting pls refer to 2.11.3, Only the 8th bit of D8401 is set differently, checking D8120 parameter setting in section 2.11.3.

Note: In modbus ASCII protocol, ADPRW command is not supported.

Program example

Master program:

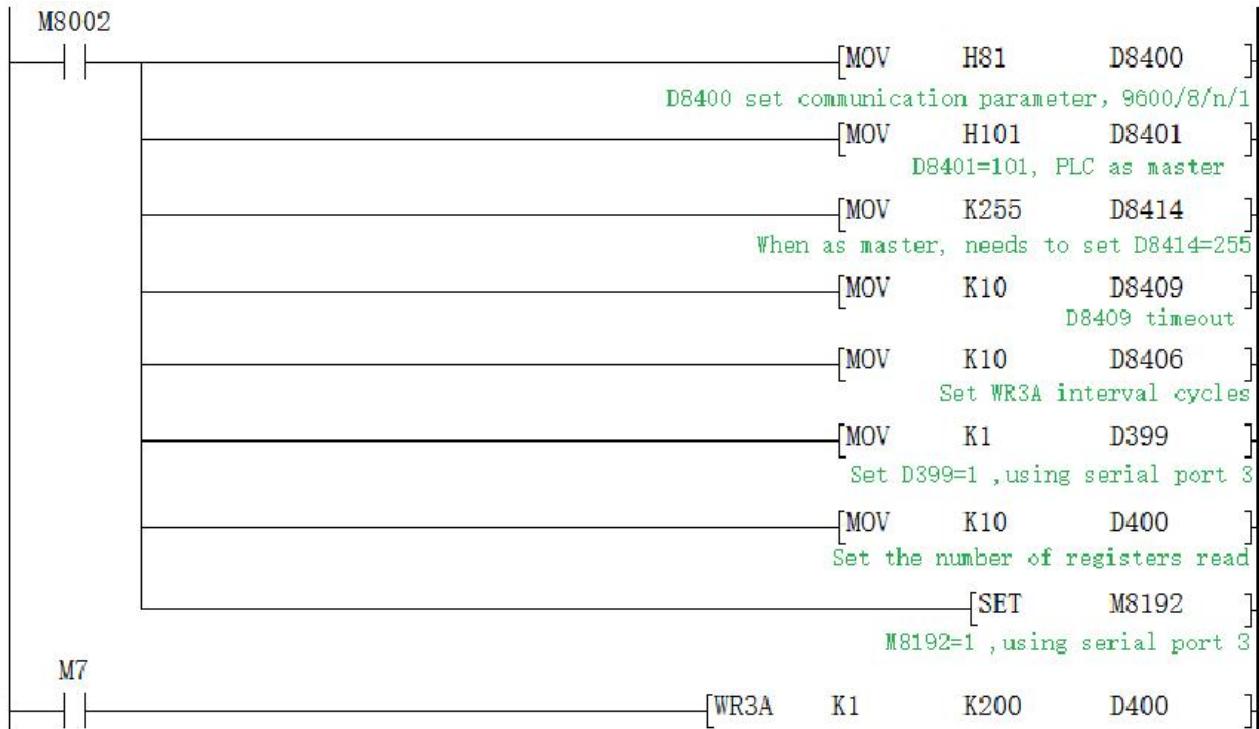

Slave program:

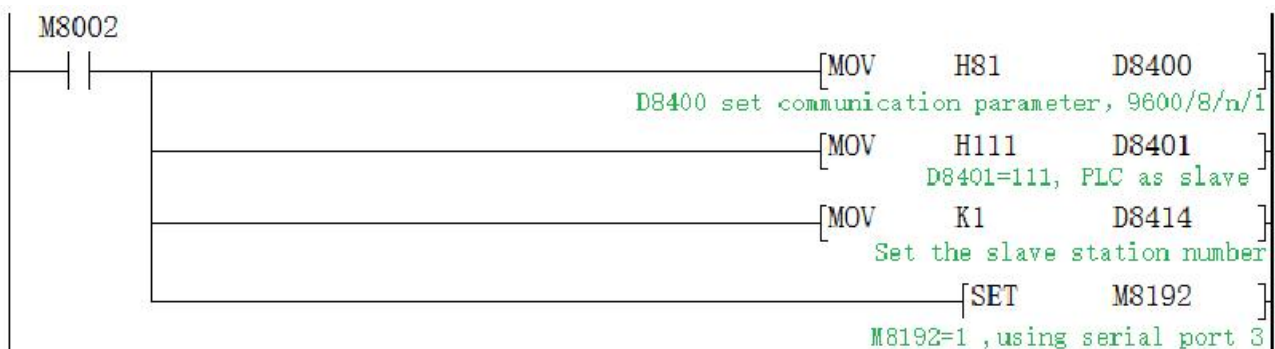

Data of the Slave D100~D109 before and after the program execution is showed as below

Soft components	+F E D C	+B A 9 8	+7 6 5 4	+3 2 1 0	
D100	0 0 0 0	0 0 0 0	0 0 0 0	0 0 0 0	0
D101	0 0 0 0	0 0 0 0	0 0 0 0	0 0 0 0	0
D102	0 0 0 0	0 0 0 0	0 0 0 0	0 0 0 0	0
D103	0 0 0 0	0 0 0 0	0 0 0 0	0 0 0 0	0
D104	0 0 0 0	0 0 0 0	0 0 0 0	0 0 0 0	0
D105	0 0 0 0	0 0 0 0	0 0 0 0	0 0 0 0	0
D106	0 0 0 0	0 0 0 0	0 0 0 0	0 0 0 0	0
D107	0 0 0 0	0 0 0 0	0 0 0 0	0 0 0 0	0
D108	0 0 0 0	0 0 0 0	0 0 0 0	0 0 0 0	0
D109	0 0 0 0	0 0 0 0	0 0 0 0	0 0 0 0	0
D110	0 0 0 0	0 0 0 0	0 0 0 0	0 0 0 0	0

Monitor D100-D109 data before the master M7 turns on.

Soft components	+F E D C	+B A 9 8	+7 6 5 4	+3 2 1 0	
D100	0 0 0 0	0 0 0 0	0 0 0 0	1 0 1 1	11
D101	0 0 0 0	0 0 0 0	0 0 0 0	1 0 1 1	11
D102	0 0 0 0	0 0 0 0	0 0 0 0	1 0 1 1	11
D103	0 0 0 0	0 0 0 0	0 0 0 0	1 0 1 1	11
D104	0 0 0 0	0 0 0 0	0 0 0 0	1 0 1 1	11
D105	0 0 0 0	0 0 0 0	0 0 0 0	1 0 1 1	11
D106	0 0 0 0	0 0 0 0	0 0 0 0	1 0 1 1	11
D107	0 0 0 0	0 0 0 0	0 0 0 0	1 0 1 1	11
D108	0 0 0 0	0 0 0 0	0 0 0 0	1 0 1 1	11
D109	0 0 0 0	0 0 0 0	0 0 0 0	1 0 1 1	11
D110	0 0 0 0	0 0 0 0	0 0 0 0	0 0 0 0	0

Monitor D100-D109 data after the master M7 turns on.

2.12.4 CAN communication port

Support RS2 protocol and MODBUS RTU protocol. (**Note:** The PLC must be disconnected (at least 15 seconds) after the CAN port is set.)

The special relays and registers related are as below:

Functions	Serial port 2(A/B)	Serial port 3(A1/B1)	CAN(H/L)	Remark
Programming port	M8196=0	M8192=0	-	Power lost can not be retentive
Freeport protocol function	M8196=1 M8125=0	M8192=1	-	
RS/RS2 sending mark	M8122=1	M8402=1	M8422=1	
RS/RS2 sending completion mark	-	-	M8425	Need to reset manually
RS/RS2 receiving completion mark	M8123	M8403	M8423	Need to reset manually
RS/RS2 receiving process mark	M8124	M8404	M8424	Data is receiving
RS/RS2 command 8/16 bits differentiation mark	M8161	M8161	M8161	
RS2 command CAN master-slave mark	-	-	M8426	M8426=0 master-slave mode, M8426=1 multi-device mode

RS2 command end operation settings	-	1	2	
MODBUS function	M8196=1 M8125=1	M8192=1	-	
RD3A/WR3A Receive correct mark	M8128	M8408	M8428	Automatic reset
RD3A/WR3A communication over-time mark	M8129	M8409	M8429	Automatic reset
ADPRW command completion mark	M8029	M8029	M8029	Command execution end mark
Communication parameters	D8120	D8400	D8420	
Communication mode	-	D8401	D8421	
Master-slave station number	D8121	D8414	D8434 D8440 D8442	D8434:CAN slave station number D8440/D8442 multi-device mode ID number
RD3A/WR3A time-out period	D8129	D8409	D8429	Unit: ms, see explanation for detailed settings
RD3A/WR3A interval period	D8126	D8406	D8426	
RD3A\WR3A end operation -1	0	1	2	
ADPRW command settings	D8397=0	D8397=1	D8397=2	
CAN data frame	-	-	M8427	

The special relays and registers related are as below.

Special relay involved: M8426,M8422,M8424,M8425.

Special register involved: D8420,D8421,D8126,D8397(version in 26232 and above),D8440,D8442.

M8422: Send data and needs manual reset.

M8423: Date receiving completion.

M8424: Data is under receiving.

M8425: The transmission is completed and needs manual reset.

M8426: Switch between multi-machine mode and master-slave mode

M8426=1: CAN is in multi-machine mode, there is no master-slave division, and it can transmit up to 8 bytes of data.

M8426=0: CAN is the master-slave mode. There must be one master on the bus line, which is similar to the MODBUS function.

M8427: =0 means setting as CAN2.OB extension frame. =1 means setting as CAN2.OA standard frame.

M8428: Set as ON while right response of MODBUS communication and needs manual reset.

M8429: Communication times out.

D8420: Communication parameters.

D8420: The 0th to 9th bits are CAN baud rate, 1K~1023K. The default is 500.

Supported baud rate:5 10 15 20 25 40 50 62 80 100 125 200 250 400 500 666 800 1000.

D8421: Communication protocol and description of master-slave station.

RS2 command: Setting as D8421=H10, which means RS protocol.

RD3A, WR3A, ADPRW command: D8421=H1 is master station, D8421=H10 is slave station.

D8397: When using the ADPRW instruction, set the D8397 to 2 when using CAN. D8426: Interval period. Default as 12 times.

D8429: Time-out period; (The unit is milliseconds, it is recommended to set: when the communication rate is greater than or equal to 9600,D8429 is set to 10~20; when the communication rate is set to less than 9600, D8429 is set to 20~50.); when use RD3A and WR3A, master over-time period set is bigger 6 than slave over-time period.

D8434: Slave station number.

D8440: Save the local ID number (slave station number).

D8442: When multiplexed, save the slave ID number (the slave what data is read).

D8421 Parameter setting

b0	Select protocol 0: Other communication protocol 1: MODBUS protocol
b1~b3	Unavailable, Set 0
b4	Master/Slave setting 0: MODBUS Master 1: MODBUS Slave
b5~b7	Unavailable, Set 0
b8	RTU/ASCII Mode selection 0:RTU 1:ASCII
b9~b15	Unavailable, Set 0

2.12.4.1 Free port protocol function

When use RS2 command , multiple channels can be interconnected, and each communicated PLC can be distinguished by an ID number.

D8440 saves the local ID number, D8442 saves the ID number of the PLC where the data is read in; ID number uses 32 bits registers, but the setting can only use 29 bits, that is, the upper 3 bits have no effect.

Up to 8 lengths of data can be sent when using RS2 command.

Program example:

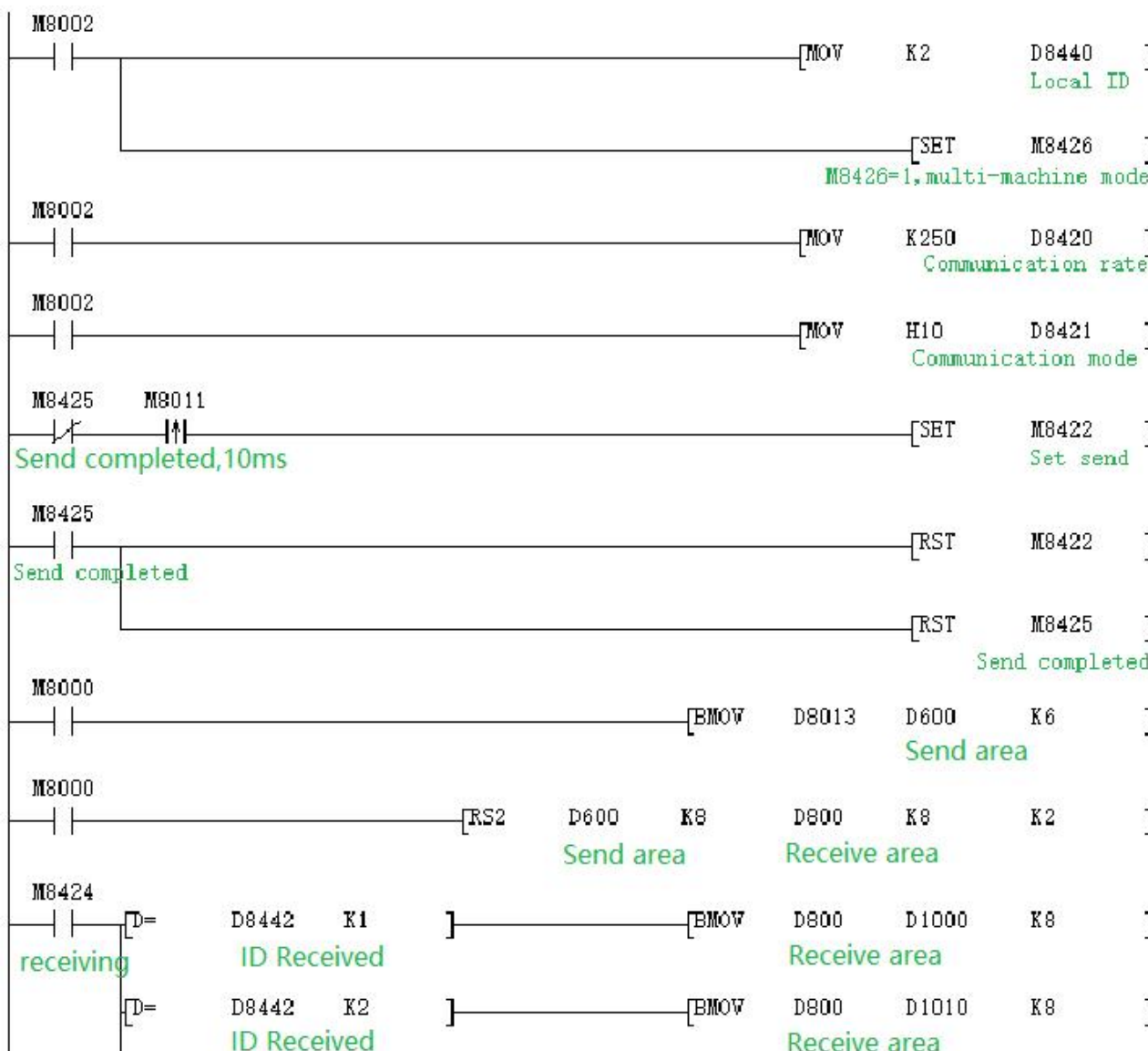

RS2 command last parameter =1: Serial port 3;
=2: CAN.

2.12.4.2 Modbus RTU Function RD3A/WR3A command

RD3A Program Example (refer to 2.11.1.1):

Master Program:

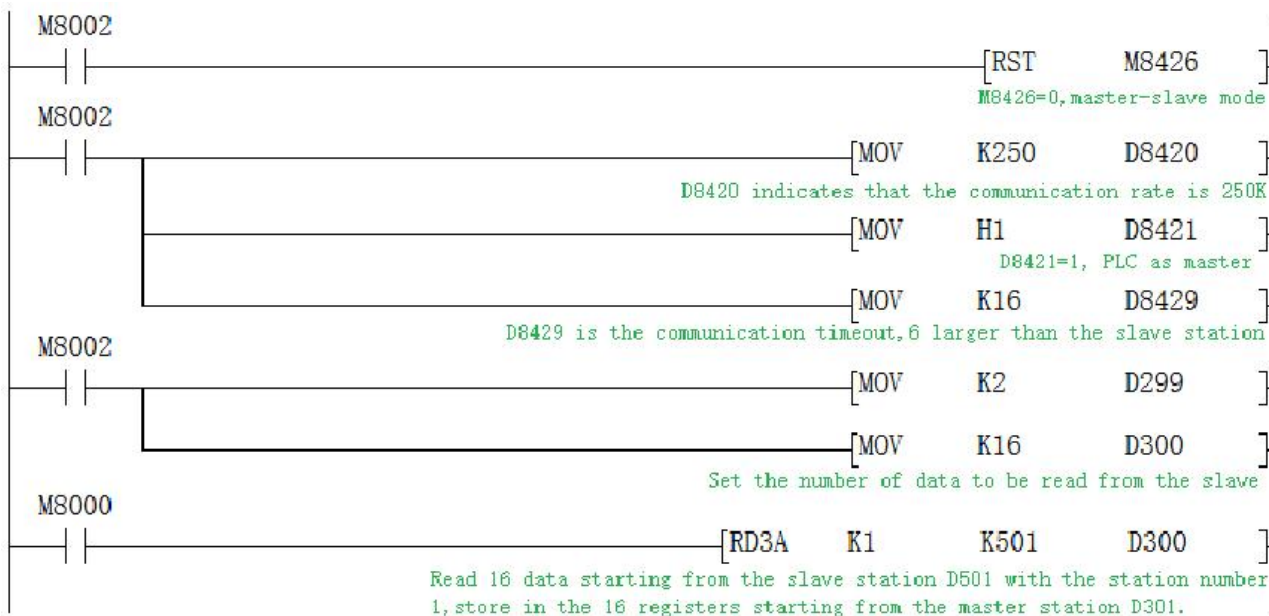

Slave Program:

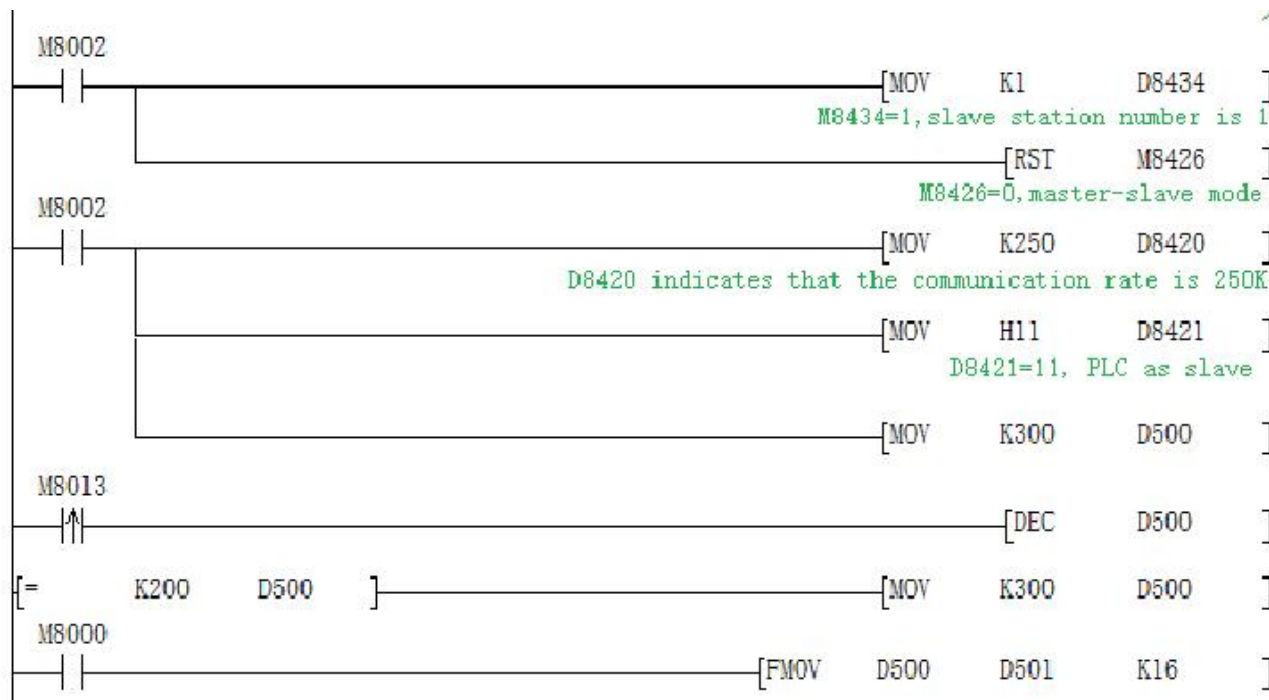

Monitoring the Master station program, the master station 16 data of D301-D316 change between 300-200 at a rate of minus 1 per second.

WR3A Program Example (refer to 2.11.1.1):

Master Program:

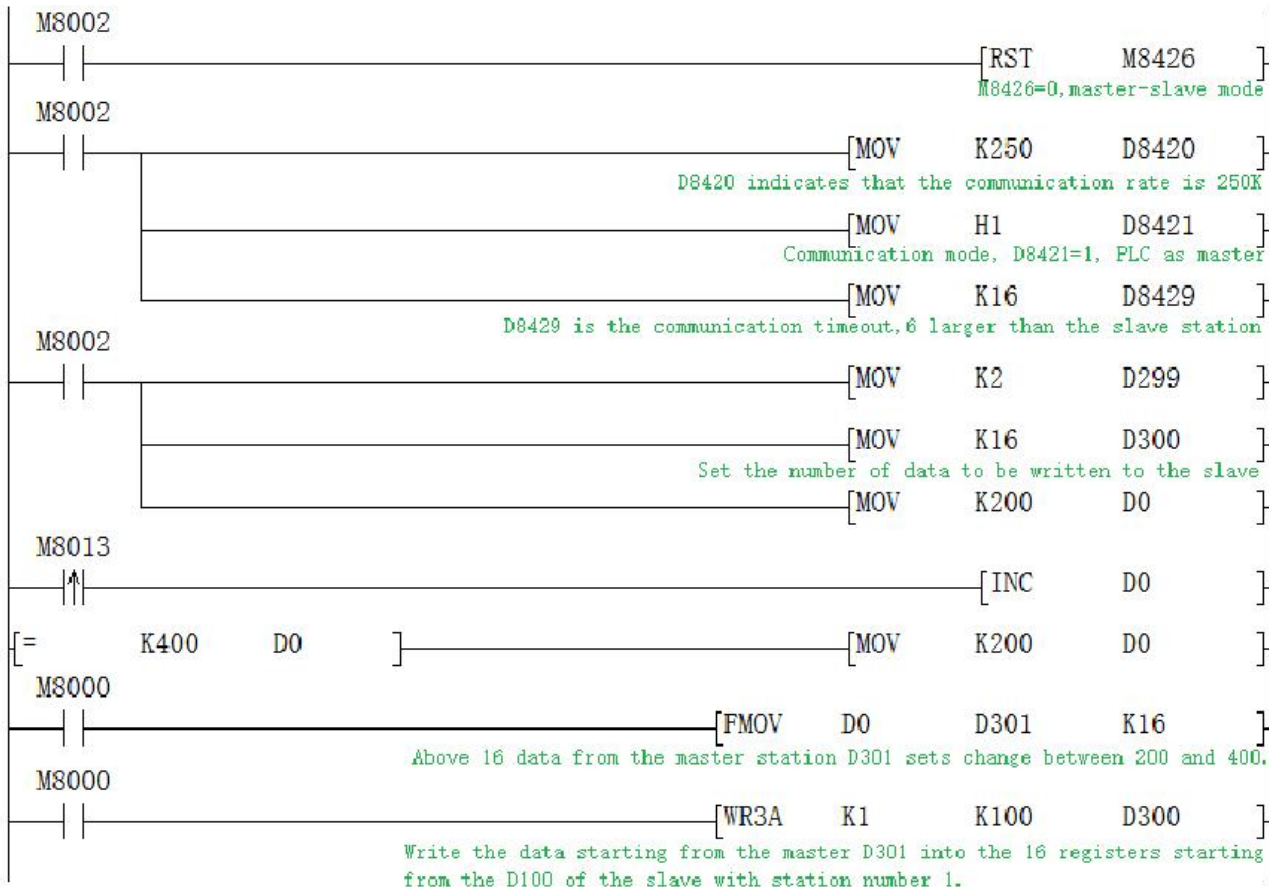

Slave Program:

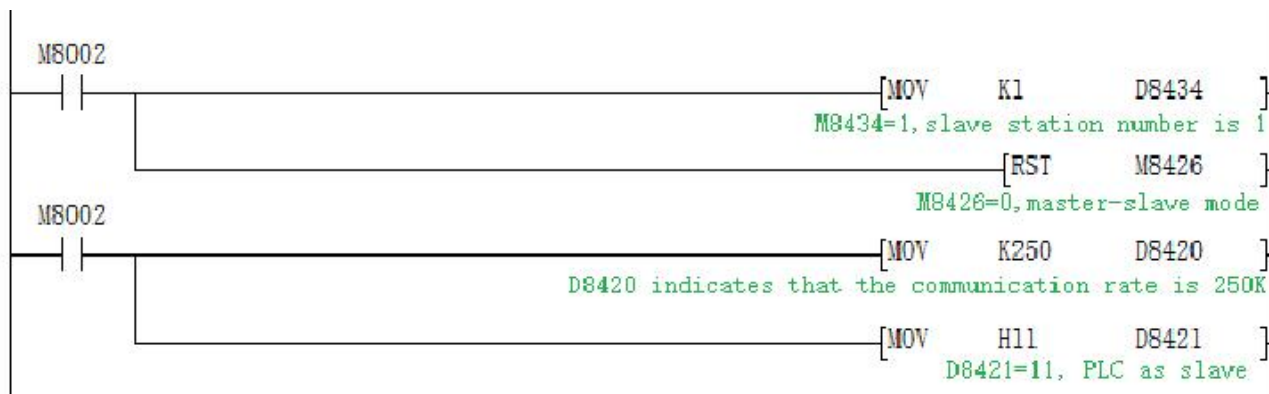

Monitoring the Slave station program, the slave station 16 data of D100-D115 change between 200-400 at a rate of plus 1 per second.

2.12.4.3 Modbus RTU Function ADPRW command

01 input register ADPRW program example (refer to 2.11.1.2)

Master Program:

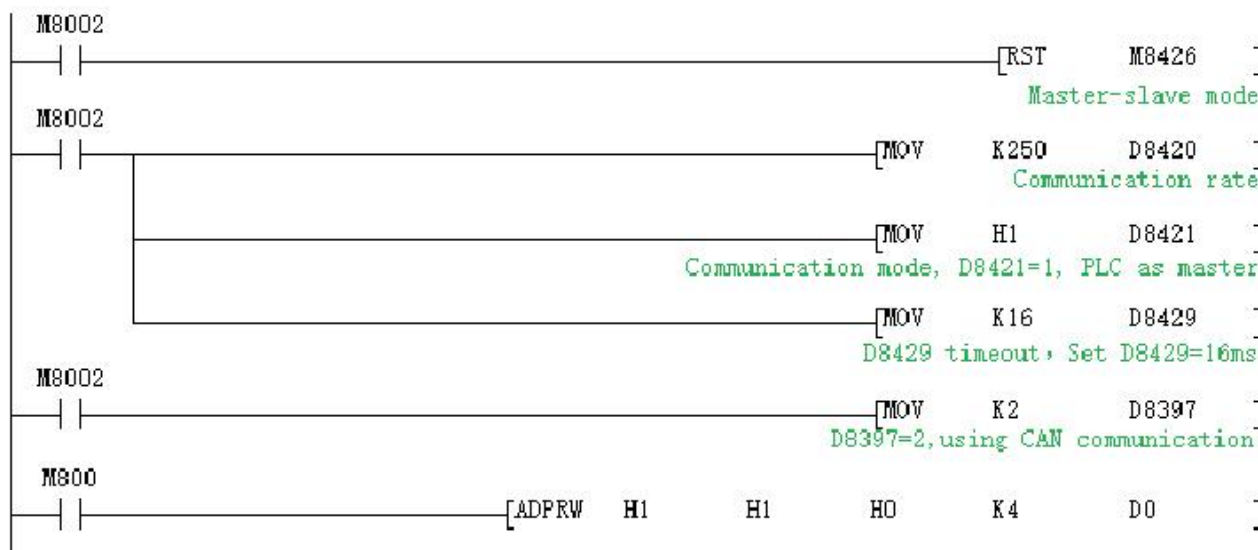

Slave Program:

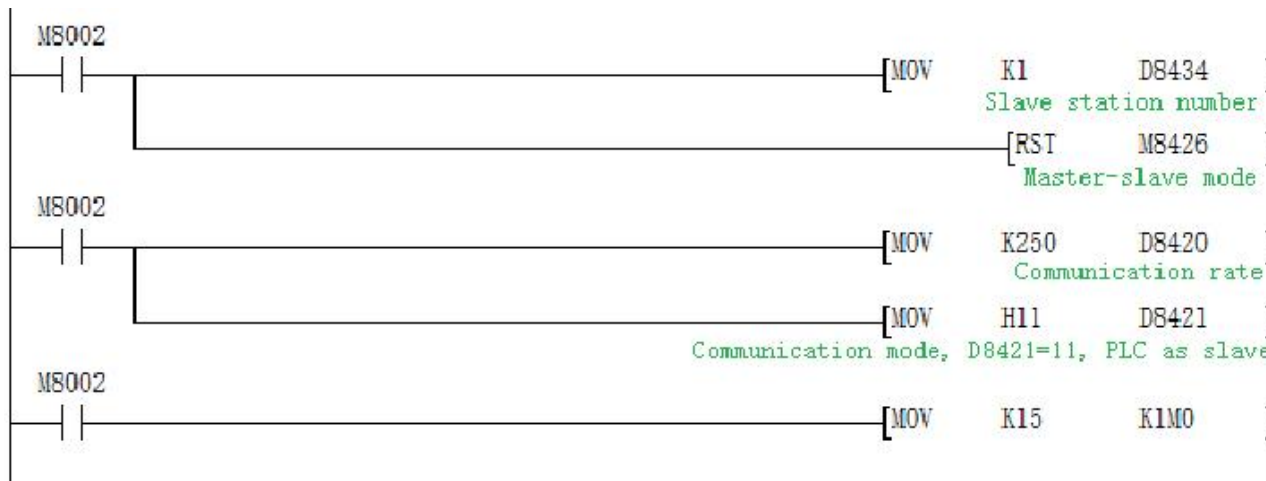

CAN port of the the PLC communicates with the CAN port of the slave PLC, and reads from the 4 bits M0~M3 of the slave PLC to the D0 of the master PLC.

2.12.5 Network communication

Automatically detect the network after power-on. M8193=1 when there is a network chip, network preparation.

Special relays, registers and registers that IP addresses used are as below.

Functions	Network	Remark
Network preparation	M8193	
Write network address	M8197	
MODBUS time out	M8062	
IP address conflict	M8063	
Automatically obtain current IP	M8324	

address		
Switch mark between Mitsubishi functions and MODBUS	D8395	
ADPRW command settings	D8397=3	
Router address	R23800 R23801	
Mask address	R23802 R23803	
MAC address	R23804~R23806	
Local IP address	R23807 R23808	
Target IP address	R23810 R23811	
Terminal	R23812	Default as 502
RD3A/WR3A command cycling times	R23813	
MODBUS time-out period	R23814	
Send Packets numbers	R23815	
Receive Packets numbers	R23816	

M8193: =1 Represents that there is a network chip, network preparation

M8197: =1 Write network address, automatic reset (Not support 26231 version, you can write the above parameters and then restart).

M8062: =1 Represents MODBUS timeout, MODBUS_TCP is used.

M8063: =1 Represents IP address is conflict.

D8395: Switch between Mitsubishi function and MODBUS_TCP

D8395=0: Mitsubishi function

D8395=1: MODBUS_UDP Slave

D8395=2: MODBUS_UDP Master

D8395=3: MODBUS_TCP Slave

D8395=4: MODBUS_TCP Master

D8395=5: EtherNet/IP slave (server)

D8397: While using ADPRW command, it needs to set D8397 to 3 when using MODBUS_TCP.

R23800,23801 is the router address. Default:192 .168. 1 .1. Namely R23800=0XC0A8, R23801=0X0101.

R23802,23803 is the mask address, Default:0 .0. 0 .0. Namely R23802=0, R23803=0。

R23804~23806 is the MAC address, is generated by the system, basically no duplication, can also be set. **Note: MAC addresses on the same network cannot be duplicated, otherwise communication will be abnormal.**

R23807, R23808 is the local IP address. Default:192 .168. 1 .250. Namely R23807=0XC0A8, R23808=0X01FA.

R23810,R23811 is the MODBUS target IP,

R23812 Port default =502

R23813 default=100 (Cycle numbers) is the WR3A RD3A sequential execution interval.

R23814 default=20 (200ms), is the MODBUS timeout setting, only retry twice, each time = (R23814 * 5) ms.

R23815 is MODBUS InfoPacketSend.
R23816 is MODBUS InfoPacketReceive.

2.12.5.1 Modbus TCP Function RD3A/WR3A Instructions

RD3A Program Example (refer to 2.11.1.1):

Master Program:

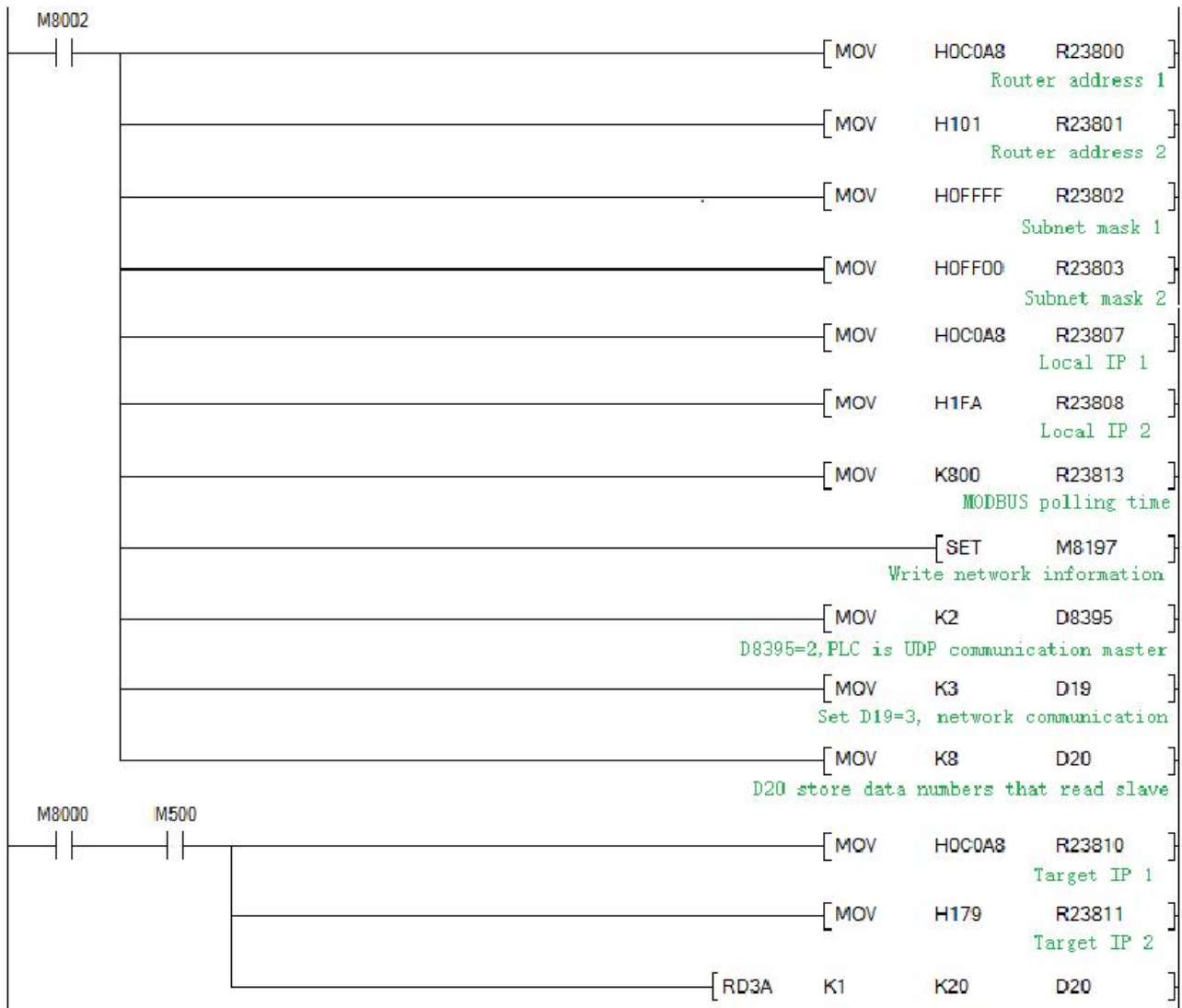

Slave Program:



2.12.6 Network N:N communication

2.12.6.1 Related device content

1.N:N network setting device

Soft element	name	content	Set value
M8038	Parameter setting	Set the flag for communication parameters. It can also be used as a flag to confirm the presence of N:N network programs. Do not turn ON in the sequence program.	
D8176	Corresponding station number setting	N:N network setting station number when using. The master station is set to 0, and the slave station is set to 1 to 15. [Initial value: 0]	0~15
D8177	Slave total number setting	Set the total number of slave stations. No setting is required in the PLC of the slave station. [Initial value: 7]	1~15
D8178	Refresh Range setting	Select the mode of the number of device points to communicate with each other. No setting is required in the PLC of the slave station. [Initial value: 0]	0~2
D8394	Serial channel selection	=2: Serial port 2 =3: Serial port 3 =4: CAN	2~4

2.Components for judging N:N network errors

M8184~M8190, M8496~M8503: The data transmission sequence error flag of the slave station.

When a data transmission sequence error occurs in each slave station, the corresponding flag bit turns ON.

Station	1	2	3	4	5	6	7	8	9	10	11	12	13	14	15
---------	---	---	---	---	---	---	---	---	---	----	----	----	----	----	----

No															
Relay	M8184	M8185	M8186	M8187	M8188	M8189	M8190	M8496	M8497	M8498	M8499	M8500	M8501	M8502	M8503

3.Link device

It is a device for sending and receiving information between programmable controllers. The device number and the number of points used differ depending on the station number set in the corresponding station number setting and the mode set in the refresh range setting.

1) Mode 0 (D8178=0):

Station No	Station 0	Station 1	Station 2	Station 3	Station 4	Station 5	Station 6	Station 7
Word device (4 points each)	D0~D3	D10~D13	D20~D23	D30~D33	D40~D43	D50~D53	D60~D63	D70~D73
Station No	Station 8	Station 9	Station 10	Station 11	Station 12	Station 13	Station 14	Station 15
Word device (4 points each)	D80~D83	D90~D93	D100~D103	D110~D113	D120~D123	D130~D133	D140~D143	D150~D153

2) Mode 1 (D8178=1):

Station No	Station 0	Station 1	Station 2	Station 3	Station 4	Station 5	Station 6	Station 7
Bit device (32 points each)	M1000~M1031	M1064~M1095	M1128~M1159	M1192~M1223	M1256~M1287	M1320~M1351	M1384~M1415	M1448~M1479
Word device (4 points each)	D0~D3	D10~D13	D20~D23	D30~D33	D40~D43	D50~D53	D60~D63	D70~D73

Station No	Station 8	Station 9	Station 10	Station 11	Station 12	Station 13	Station 14	Station 15
Bit device (32 points each)	M1512~M1543	M1576~M1607	M1640~M1671	M1704~M1735	M1768~M1799	M1832~M1863	M1896~M1927	M1960~M1991
Word device (4 points each)	D80~D83	D90~D93	D100~D103	D110~D113	D120~D123	D130~D133	D140~D143	D150~D153

3) Mode 2 (D8178=2):

Station No	Station 0	Station 1	Station 2	Station 3	Station 4	Station 5	Station 6	Station 7
Bit device (64 points each)	M1000~ M1063	M1064~ M1127	M1128~ M1191	M1192~ M1255	M1256~ M1319	M1320~ M1383	M1384~ M1447	M1448~ M1511
Word device (8 points each)	D0~D7	D10~ D17	D20~ D27	D30~ D37	D40~ D47	D50~ D57	D60~ D67	D70~ D77
Station No	Station 8	Station 9	Station 10	Station 11	Station 12	Station 13	Station 14	Station 15
Bit device (64 points each)	M1512~ M1575	M1576~ M1639	M1640~ M1703	M1704~ M1767	M1768~ M1831	M1832~ M1895	M1896~ M1959	M1960~ M2023
Word device (8 points each)	D80~ D87	D90~ D97	D100~ D107	D110~ D117	D120~ D127	D130~ D137	D140~ D147	D150~ D157

2.12.6.2 Program setting and description

The program settings are as shown below. It is recommended to set the timeout wait register D8129/D8409/D8429 above 12. It is only necessary to set the corresponding special register to achieve the data sharing of the corresponding interval register and auxiliary relay. Channel M8184~M8190 and the rear 8 channels M8496~M8503, you can check the status of each slave, if there is no connection, turn ON

1. Serial port 2

Master program:

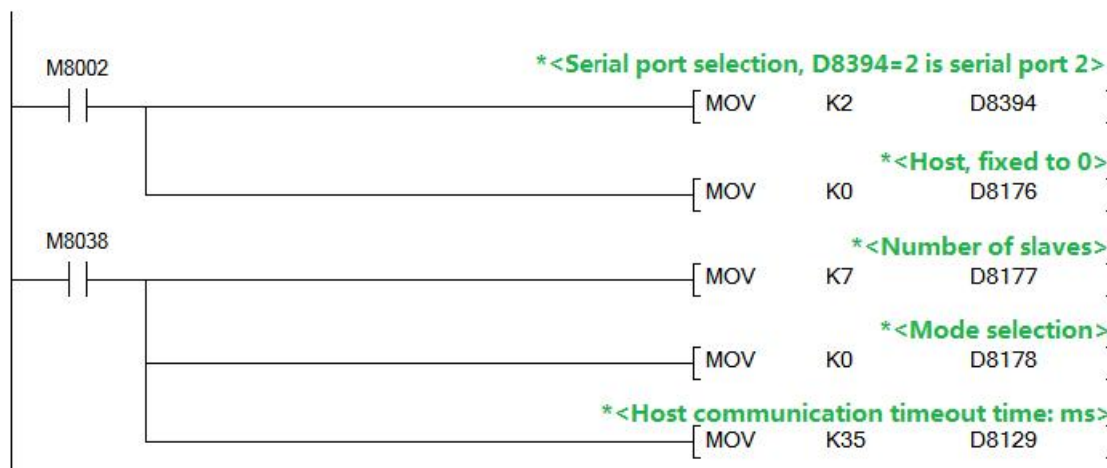

Slave program:

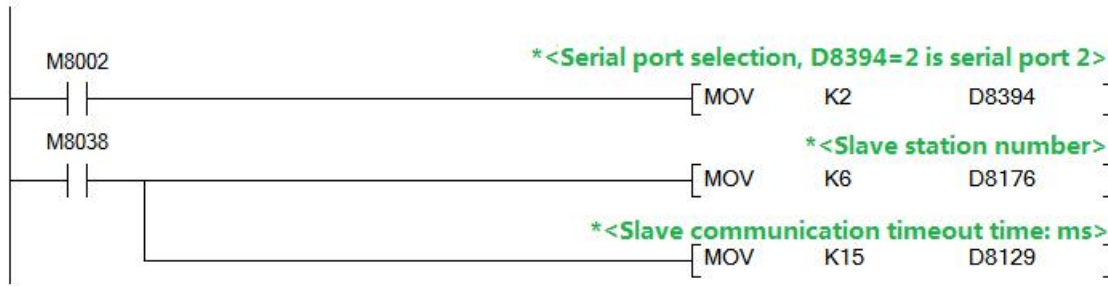

2. Serial port 3

Such as serial port 2, only need the master and slave program to set D8394=3

3. CAN port

Master program:

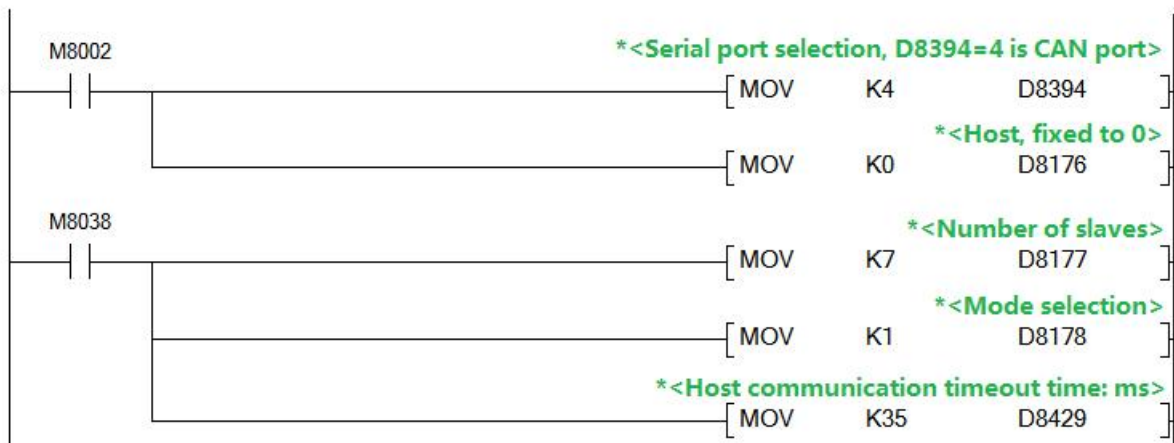

Slave program:

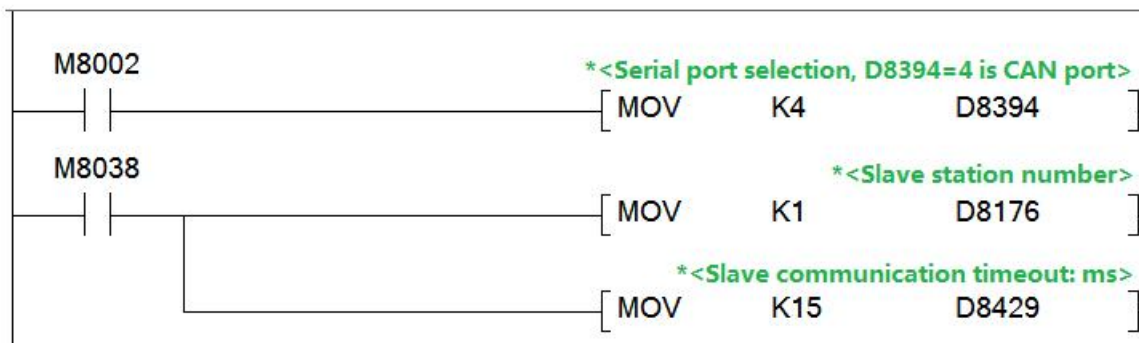

3. HMI

3.1 HMI program software user introduction

3.1.1 HMI Program software installation

The touch screen software is CoolMayHMI touch screen software, which is compatible with XP/WIN7/WIN8/WIN10 systems. If it cannot be installed and used, it is recommended to try methods such as replacing the computer, reinstalling the system, or obtaining higher user permissions to troubleshoot the problem.

Installation method: Double click Vcool *. *. exe and follow the prompts to click Next. When installing software, a driver installation prompt box will pop up.



If you click "Cancel", the USB driver will not be installed this time.

If you click "Next", the system will install the USB driver. After completion, a prompt box below will pop up, indicating that the driver has been installed.

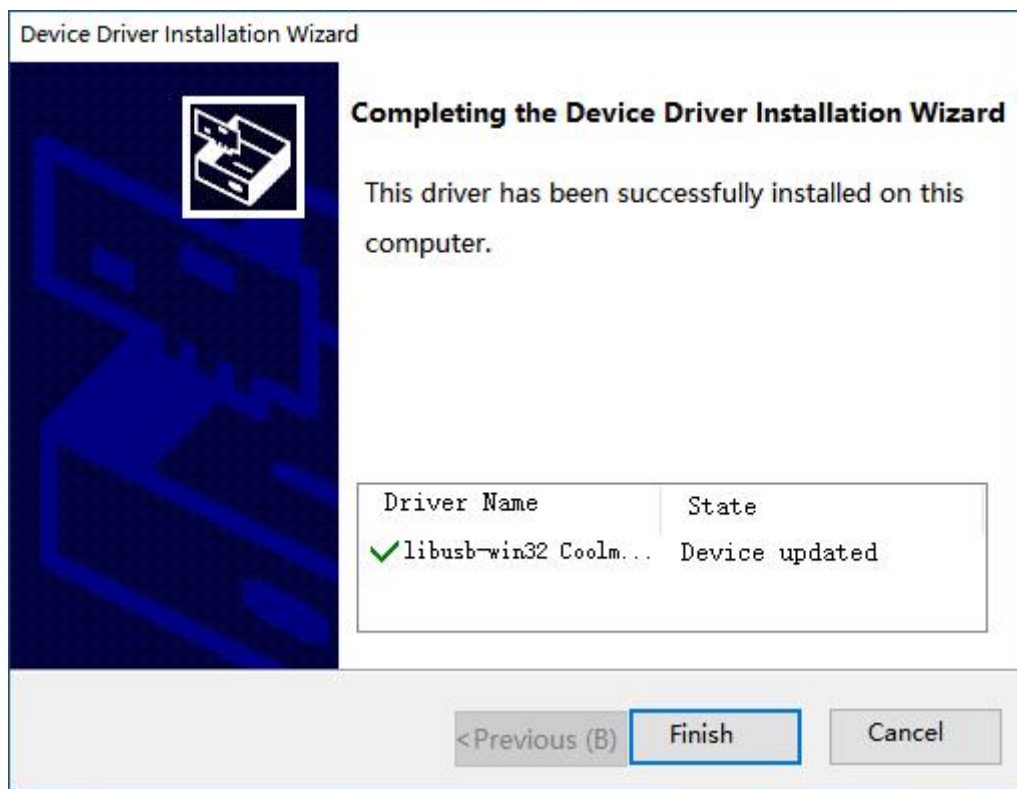

3.1.2 Create new touch screen program



1. Double click , then Click [New]

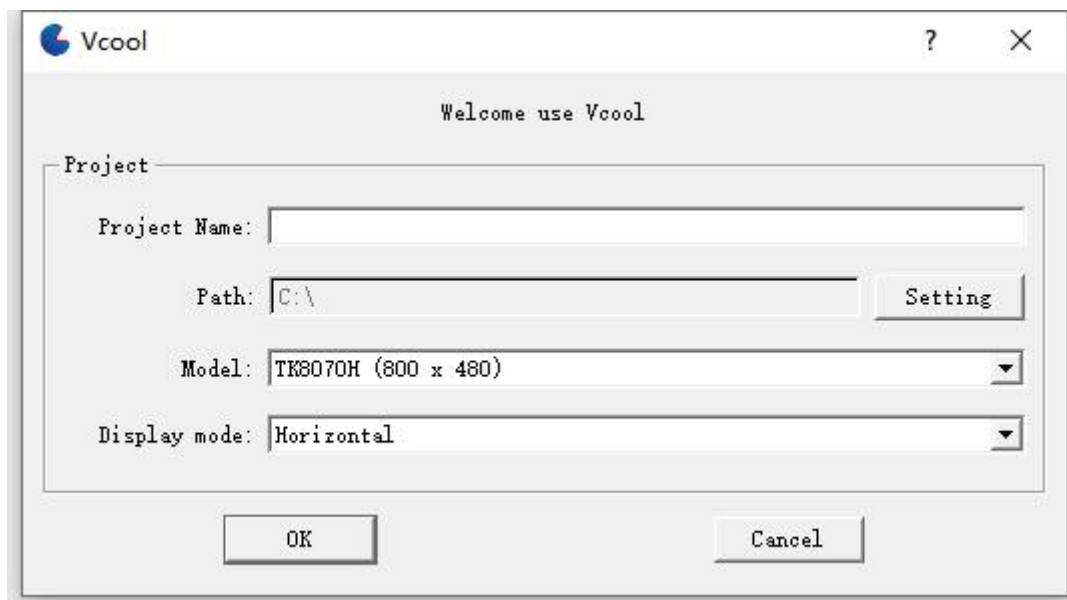

2. Set the project name, select the corresponding model, and confirm

- EX3G-8043H select TK8043H (480x272);
- EX3G-8050H select TK8050H (800x480)
- EX3G-8070H select TK8070H (800x480)
- EX3G-8070HD select TK88070HD (1024x600)
- EX3G-8100Hselect TK8100H (1024x600)

3.Set communication protocol: Add - select "Device Manufacturer" and "Name"; Set the required communication parameters and click OK to start editing the screen program.

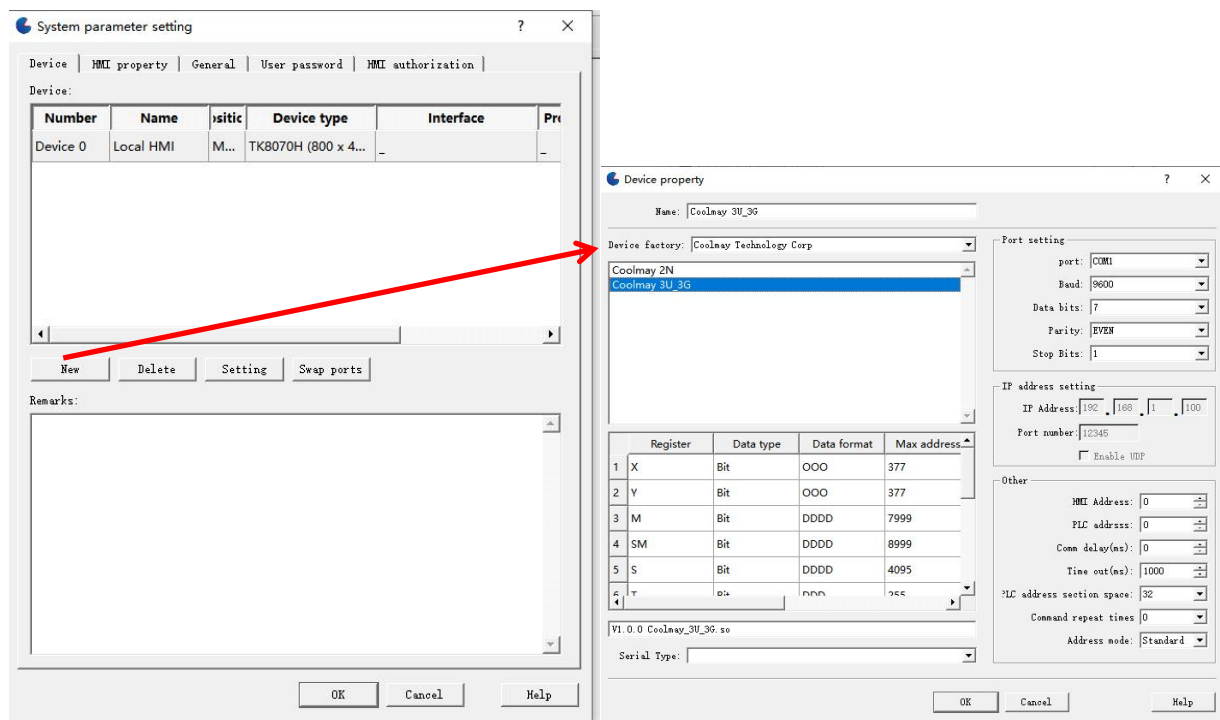

3.2 HMI Display download

3.2.1 Online download step (Type-C/Type-B download line download)

1. After saving the program, click on Tools in the software - Compile;

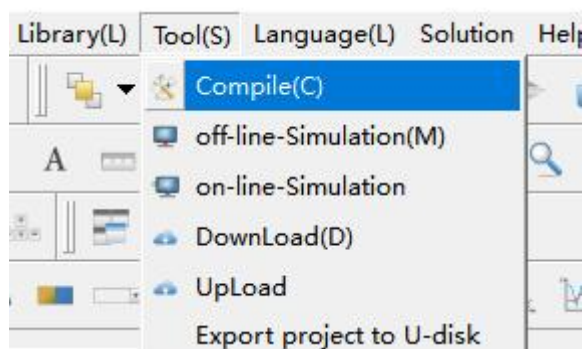

After successful compilation, you can click on download or click on the icon on the toolbar to pop up a dialog box;

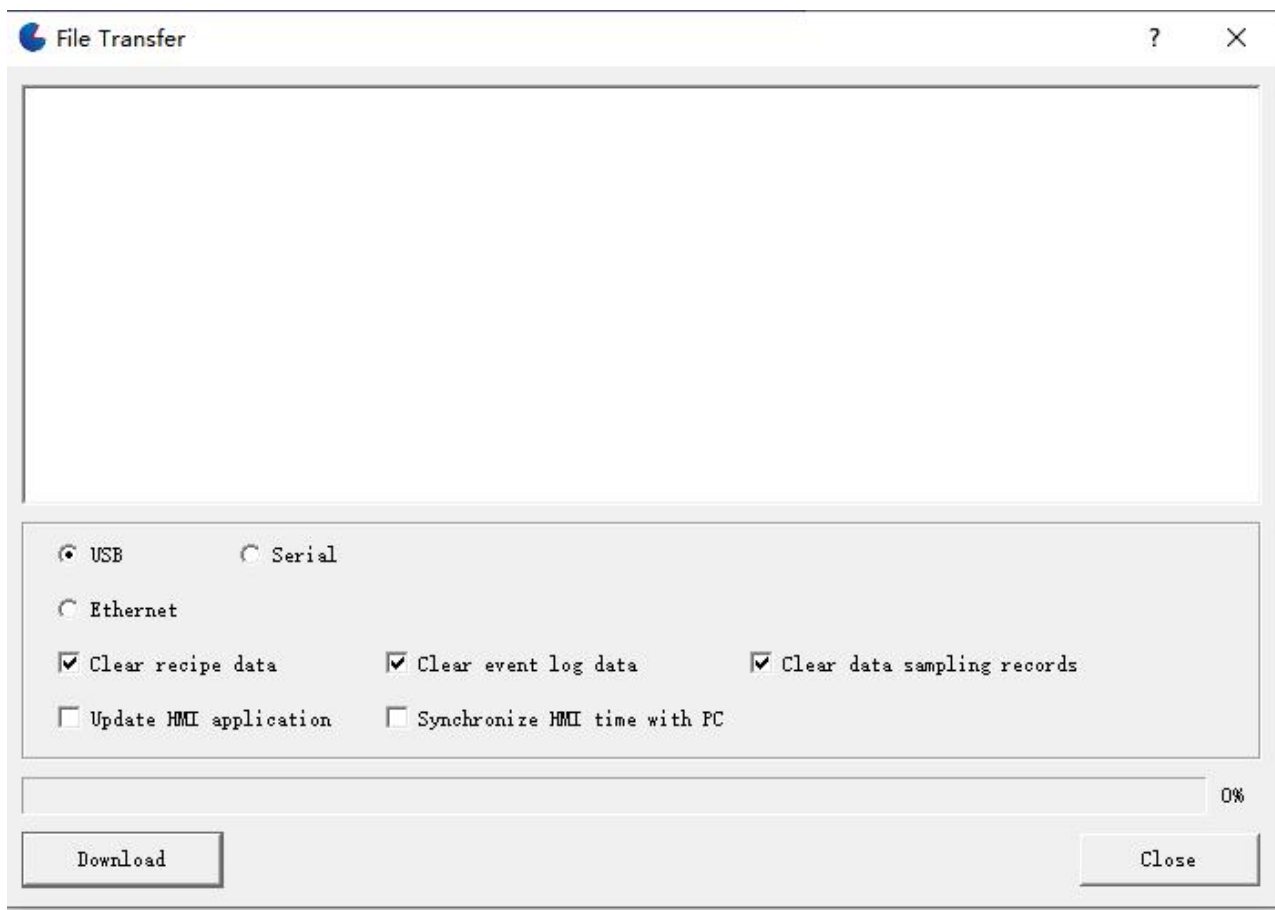

Select "USB Download": It is necessary to connect the touch screen and computer via USB and ensure that the touch screen driver is installed correctly.

Select "Serial Port Download": The touch screen and computer need to be connected via RS232 or RS485, and then the corresponding COM port needs to be specified.

Select "Ethernet": You need to connect the touch screen to the network, and then specify the IP address and port.

Clear recipe data: After downloading, set all recipe data to 0.

Clear event record data: After downloading, clear the historical event database.

Clear data sampling records: After downloading, clear the data sampling database.

Update lower level program: Download the attached lower level program to HMI simultaneously and complete the update, which can be used for upgrading the lower level program.

Synchronize HMI time with computer: Synchronize HMI with the current computer.

Finally, click download, and the currently copied resource will be displayed in the list box. At the same time, the touch screen will also display the download progress.

3.2.2 Configuration engineering upload

Uploading refers to uploading configuration engineering, event data, etc. from the touch screen to the computer. Click on the icon on the toolbar to pop up a dialog box:

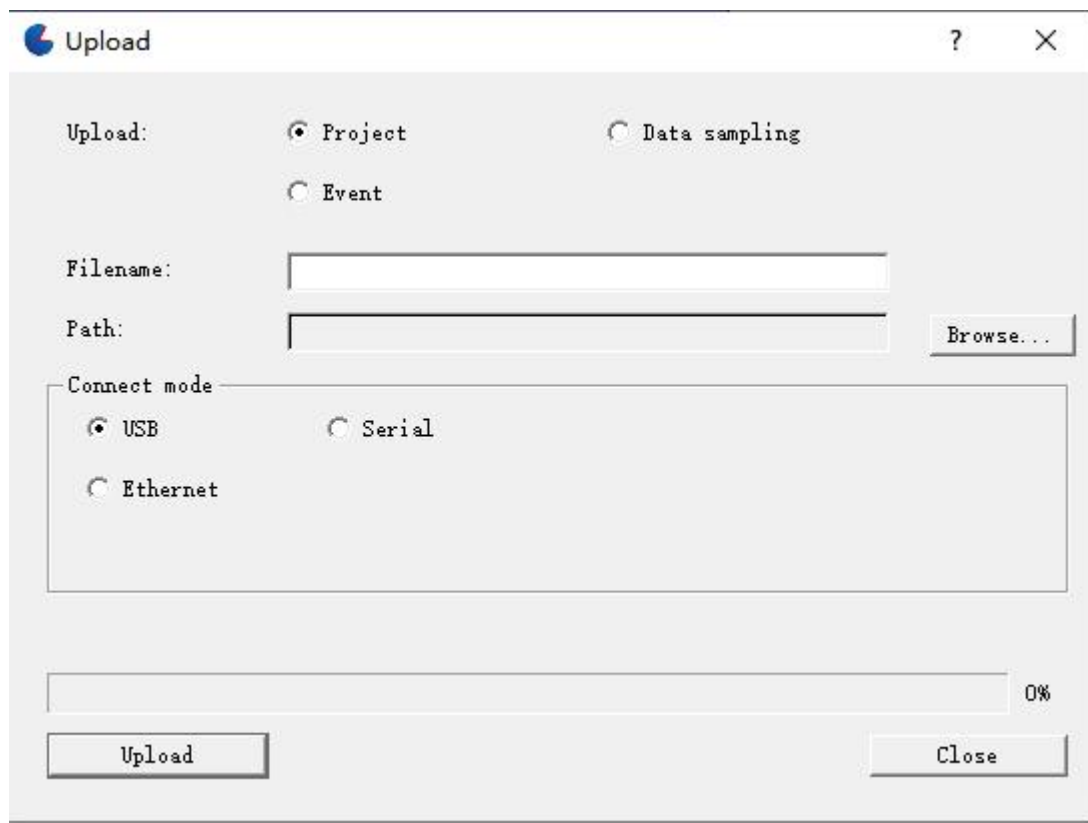

Upload content: You can choose engineering files, data sampling, or event records.

Connection method: USB transmission, serial port transmission, or Ethernet transmission can be selected. The default port for Ethernet transmission is 12345.

When you choose to upload the "project file", you will receive a PRJ project file.

When choosing to upload "data sampling", a tar.bz2 compressed file can be obtained, and decompression can obtain the data sampling database file.

When selecting to upload "event records", a tar.bz2 compressed file can be obtained, which can be decompressed to obtain the event database file.

3.2.3 U disk download step

In addition to downloading configuration project files through USB and Ethernet, there is another method for exporting projects, which is to update them through a USB drive.

Select the "Tools" menu - "Export Project to USB Drive"

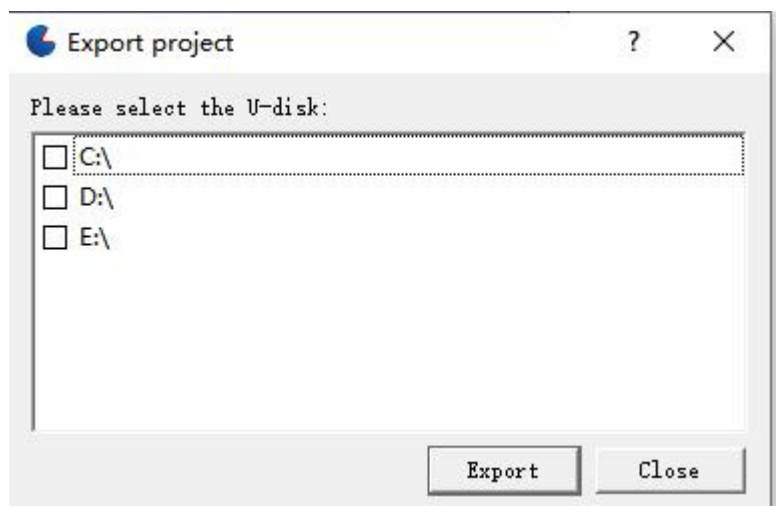

Select a USB drive path (multiple options can be selected, or the local disk can be used as a USB drive), click "Export", and the current project will be compiled first. After successful compilation, the generated project.bin file will be copied to the selected USB drive. By using this USB flash drive, combined with the "Engineering Update" section in "Touch Screen Parameter Settings", the configuration engineering in the touch screen can be updated.

3.3 Other HMI usage.

Other touch screen software usage can be found in the **Coolmay TK80 series touch screen user manual**

Appendix

Version Change Record

Date	Changed version	Change content
Feb. 2024	V24.21	◆ First version release
July. 2024	V24.71	<ul style="list-style-type: none"> ◆ Modify 1.2 product parameters ◆ Add 2.8 weighing function description
Dec.2024	V24.121	◆ 2.6 Analog Input added instructions for 16-bit isolated analog precision