

Ruijie Reyee RG-NIS2100 Series Switch

Installation Guide

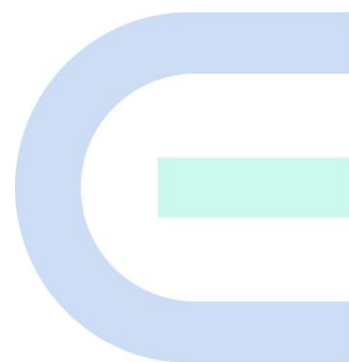

Copyright

Copyright © 2026 Ruijie Networks

All rights are reserved in this document and this statement.

Any reproduction, excerpt, backup, modification, transmission, translation or commercial use of this document or any portion of this document, in any form or by any means, without the prior written consent of Ruijie Networks is prohibited.

 and other Ruijie networks logos are trademarks of Ruijie Networks.

All other trademarks or registered trademarks mentioned in this document are owned by their respective owners.

Disclaimer

The products, services, or features that you purchase are subject to commercial contracts and terms. It is possible that some or all of the products, services, or features described in this document may not be available for purchase or use. Unless agreed upon otherwise in the contract, Ruijie Networks does not provide any explicit or implicit statements or warranties regarding the content of this document.

The names, links, descriptions, screenshots, and any other information regarding third-party software mentioned in this document are provided for your reference only. Ruijie Networks does not explicitly or implicitly endorse or recommend the use of any third-party software and does not make any assurances or guarantees concerning the applicability, security, or legality of such software. You should choose and use third-party software based on your business requirements and obtain proper authorization. Ruijie Networks assumes no liability for any risks or damages arising from your use of third-party software.

The content of this document is subject to constant change due to product version upgrades or other reasons. Thus, Ruijie Networks reserves the right to modify the content of the document without prior notice or prompt.

This manual serves solely as a user guide. While Ruijie Networks endeavors to ensure the accuracy and reliability of the content when compiling this manual, it does not guarantee that the content of the manual is free of errors or omissions. All information contained in this manual does not constitute any explicit or implicit warranties.

Preface

Intended Audience

This document is intended for:

- Network engineers
- Technical support and servicing engineers
- Network administrators

Technical Support

- Ruijie Reeye website: <https://reyee.ruijie.com>
- Online support center: <https://reyee.ruijie.com/en-global/support>
- Case portal: <https://www.ruijie.com/support/caseportal>
- Community: <https://community.ruijie.com>
- Email support: service_rj@ruijie.com
- Live chat: <https://reyee.ruijie.com/en-global/rita>

Conventions

1. Signs

This document also uses signs to indicate some important points during the operation. The meanings of these signs are as follows:

Caution

An alert that calls attention to safety instruction that if not understood or followed can result in personal injury.

Warning

An alert that calls attention to important rules and information that if not understood or followed can result in data loss or equipment damage.

Note

An alert that calls attention to essential information that if not understood or followed can result in function failure or performance degradation.

Instruction

An alert that contains additional or supplementary information that if not understood or followed will not lead to serious consequences.

✔ Specification

An alert that contains a description of product or version support.

2. Notes

This manual presents installation instructions, troubleshooting techniques, technical specifications, cable and connector requirements, and usage guidelines. It is intended for users who want to gain insight into the above content and have some experience in installing and maintaining network hardware. It is assumed that users are already familiar with relevant terms and concepts.

Contents

Preface	1
1 Product Overview	1
1.1 Package Contents.....	1
1.2 Introduction to RG-NIS2100	1
1.3 RG-NIS2100-8GT2SFP-HP	2
1.3.1 Product Appearance	2
1.3.2 Technical Specifications.....	7
1.4 RG-NIS2100-4GT2SFP-HP	11
1.4.1 Product Appearance	11
1.4.2 Technical Specifications.....	16
2 Preparing for Installation	20
2.1 Safety Precautions.....	20
2.1.1 General Safety	20
2.1.2 Handling Safety.....	20
2.1.3 Electric Safety	20
2.1.4 Electrostatic Discharge Safety.....	21
2.1.5 Laser Safety	21
2.2 Installation Environment Requirements.....	22
2.2.1 Bearing.....	22
2.2.2 Clearance.....	22
2.2.3 Temperature and Humidity.....	22
2.2.4 Cleanliness.....	23

2.2.5 Anti-Interference.....	24
2.2.6 Grounding.....	24
2.2.7 Surge Protection	25
2.2.8 EMI.....	25
2.3 Tools	26
3 Installing the Switch	27
3.1 Installation Procedure	27
3.2 Before You Begin.....	27
3.3 Precautions	28
3.4 Installing the Switch	28
3.4.1 Mounting the Switch on the DIN Rail.....	28
3.4.2 Mounting the Switch on the Wall	29
3.5 Grounding the Switch	30
3.6 Installing the Power Module.....	31
3.7 Connecting Cables.....	33
3.8 Bundling the Cables.....	33
3.9 Verifying Installation.....	33
4 Debugging	35
4.1 Powering On the Switch	35
4.2 Log In to the Web Interface	35
5 Common Troubleshooting.....	36
5.1 Troubleshooting Flowchart	36
5.2 Common Faults.....	36
6 Appendix.....	38

6.1 Connectors and Media.....	38
6.1.1 1000BASE-T/100BASE-TX/10BASE-T Port.....	38
6.1.2 Optical Cable Connection	39
6.2 SFP Modules	39
6.3 Surge Protection	43
6.3.1 Installing an AC Power Arrester (Lightning Resistance Socket)	43
6.3.2 Installing the Ethernet Port Arrester.....	45
6.4 Cabling Recommendations.....	47
6.4.1 Requirements for Cable Bend Radius	47
6.4.2 Requirement for the Minimum Bend Radius of an Optical Cable	47
6.4.3 Precautions for Bundling up Cables	47
6.5 Equipment Room Site Selection	50

1 Product Overview

1.1 Package Contents

Table 1-1 Package Contents

Number	Item	Quantity
1	Switch	1
2	Mounting bracket (for wall mounting)	2
3	User Manual	1
4	Warranty card	1
5	M3 x 5 mm cross recessed countersunk head screw	4

 Note

The preceding package contents are intended to provide a general overview. The actual delivery is subject to the order contract. Please check your goods carefully against the order contract. If you have any questions, please contact the distributor.

1.2 Introduction to RG-NIS2100

The RG-NIS2100 series Layer 2 industrial switches boast a unique industrial design. With Ruijie's unique self-organizing network (SON) technology and Ruijie Cloud, they have an industrial-grade operating temperature range, professional capability in outdoor lightning protection, and enterprise-class dustproof rating. They provide user-friendly features for ease of use and O&M and can withstand various harsh and complex environments.

Table 1-2 Interface Specifications of the RG-NIS2100 Series Switches

Model	10/100/1000BASE-T Ethernet Ports with Auto-Negotiation	1000BA SE-X SFP Port	Console Port	PoE Port	Power Supply
RG-NIS2100-8GT2SFP-HP	8	2	/	8	1+1 redundancy
RG-NIS2100-4GT2SFP-HP	4	2	/	4	1+1 redundancy

i Note

- 1000BASE-T ports are downward compatible with 100BASE-T and 10BASE-T ports.
- Only one power supply is used at a time, and the other power supply is used as a backup.
- The "Technical Specifications" section provides specifications for some supported power modules. For details about more power modules and their specifications, search for RG-NIS-PA Series Power Modules Installation Guide at <https://reyee.ruijie.com/en-global/resources/products>.

1.3 RG-NIS2100-8GT2SFP-HP

1.3.1 Product Appearance

The RG-NIS2100-8GT2SFP-HP full Gigabit Ethernet switch provides eight RJ45 ports supporting 10/100/1000BASE-T auto-negotiation, and two 1000Base-X SFP ports on the front panel. On the top panel, there are one dual-output DC power connector, one DIP switch, one reset button, and one grounding screw.

The product appearance is as follows.

Figure 1-1 Appearance of the RG-NIS2100-8GT2SFP-HP



1. Front Panel

Figure 1-2 Front Panel of the RG-NIS2100-8GT2SFP-HP

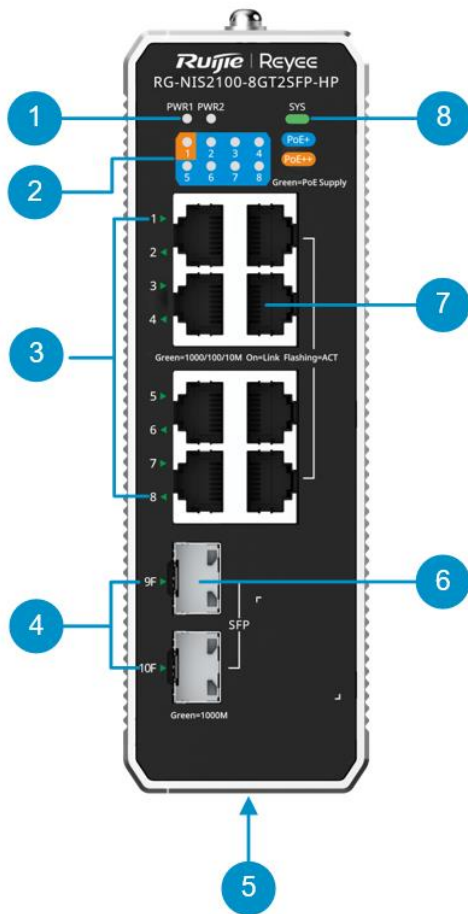

Table 1-3 Front Panel

Number	Item	Description
1	PWR LED	<ul style="list-style-type: none"> ● Off: The power supply is disabled. ● On: The power supply is enabled.
2	PoE status LED	<ul style="list-style-type: none"> ● Off: Power over Ethernet (PoE) is disabled. ● Solid green: PoE is enabled.
3	Electrical port status LED	<ul style="list-style-type: none"> ● Off: The port is not connected. ● Solid green: The port operates at 1000/100/10 Mbps and no data is transmitted. ● Blinking green: The port operates at 1000/100/10 Mbps and is transmitting data. <p>(Note: Port 1 is IEEE 802.3bt-compliant.)</p>
4	Optical port status LED	<ul style="list-style-type: none"> ● Off: The port is not connected. ● Solid green: The port operates at 1000 Mbps and no data is transmitted. ● Blinking green: The port operates at 1000 Mbps and is transmitting data.

Number	Item	Description
5	Nameplate	Nameplate on the bottom of the device
6	1000BASE-X SFP ports	SFP port for SFP module expansion
7	10/100/1000BASE-T Ethernet port with auto-negotiation	RJ45 electrical port that connects to a CAT5e network cable
8	System status LED	<ul style="list-style-type: none"> ● Off: The switch is not powered on. ● Fast blinking green (8 to 10 Hz): The switch is starting up. ● Solid green: The switch is operating normally after startup. ● Slow blinking green (0.5 Hz): The switch is operating normally after startup but does not connect to Ruijie Cloud. ● Blinking green (2 Hz): The system is restoring factory settings or upgrading.

2. Top Panel

Figure 1-3 Top Panel of the RG-NIS2100-8GT2SFP-HP

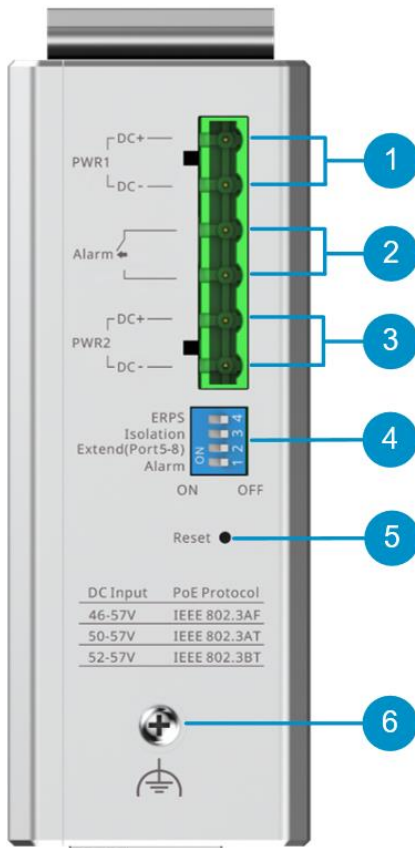

Table 1-4 Top Panel

Number	Item	Description
1	PWR1 DC power connector	Connects to a DC power supply.
2	Alarm port	<ul style="list-style-type: none"> ● In normal cases, the contact of an alarm port is closed. ● When an alarm is triggered (by power failure of a power supply), the contact is opened.
3	PWR2 DC power connector	Connects to a DC power supply.
4	DIP switch	<ul style="list-style-type: none"> ● ERPS: <ul style="list-style-type: none"> ○ On: Ethernet Ring Protection Switching (ERPS) is enabled. ○ Off: ERPS is disabled. ● Isolation: <ul style="list-style-type: none"> ○ On: Ports 1–8 cannot communicate with each other, but can communicate with ports 9 and 10. Ports 9 and 10 can communicate with each other. ○ Off: Port isolation is disabled. ● Extend(Port 5–8): Sets the rate of ports 5–8 to 10 Mbps. ● Alarm: Generates an alarm when the power module is not detected. When the switch is turned off, the alarm function is disabled.
5	Reset button	<ul style="list-style-type: none"> ● Press and hold the button for shorter than two seconds to restart the system. ● Press and hold the button for longer than five seconds until the system status LED starts blinking to restore the factory setting and restart the device. ● If the button is pressed and held for two to five seconds, no operation is triggered.
6	Grounding screw	Connects to the ground.

 Note

ERPS, port isolation, and extension mode can be configured through the DIP switch on the device panel or on Eweb. The new configuration will overwrite the old configuration.

3. Rear Panel

Figure 1-4 Rear Panel of the RG-NIS2100-8GT2SFP-HP

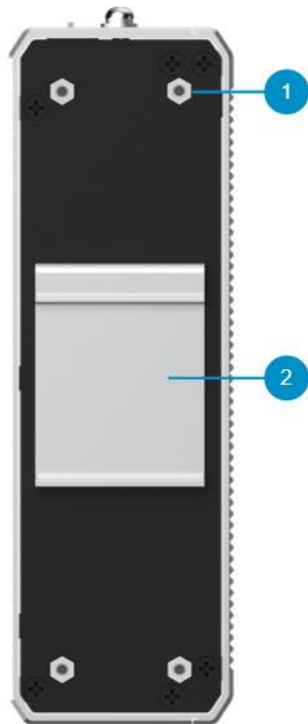

Table 1-5 Rear Panel

Number	Item	Description
1	Mounting bracket screw hole	Used to install mounting brackets
2	DIN rail clamp	Used to secure the switch to the guide rail.

i Note

When mounting the switch on a wall, secure the two screws removed from the DIN rail clamp back into their original holes to guarantee the IP40 protection level of the switch.

4. Bottom Panel

Figure 1-5 Bottom Panel of the RG-NIS2100-8GT2SFP-HP

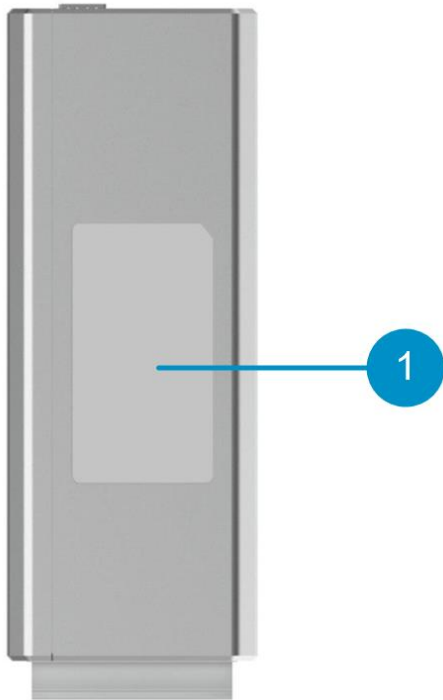

Table 1-6 Bottom Panel

Number	Item	Description
1	Nameplate	Nameplate on the bottom of the device

1.3.2 Technical Specifications

Table 1-7 Technical Specifications of the RG-NIS2100-8GT2SFP-HP

System Specifications	Flash memory	8 MB
	Forwarding rate	14.8 Mpps
	Switching capacity	20 Gbps(bit/s)
Port Specifications	Total number of RJ45 ports	8
	Total number of optical ports	2
	Number of 1GE SFP ports	2

	Number of 10/100/1000BASE-T ports	8
	Long-distance transmission	<p>Yes (ports 5–8)</p> <p>Notes:</p> <ul style="list-style-type: none"> ● Support a stable transmission distance of up to 200 m (656.17 ft.). In a lab environment, with CAT5e or better Ethernet cables, the transmission distance can reach up to 250 m (820.21 ft.). ● Refer to the note below the specifications table for other restrictions on the long-distance transmission feature.
	Reset button	1
	DIP switch	<ul style="list-style-type: none"> ● ERPS mode: Enable ERPS ring network ● Isolation mode: Upper port and lower port isolation ● Extend mode: The rate of Ports 5 to 8 is reduced to 10 Mbps, but the maximum transmission distance can be up to 200 meters (Cat5e cables required) ● Alarm mode: Turn on power in-position detection alarm
	Supported Optical Module Models	For details, see 6.2 SFP Module . Copper cables are not supported.
Power Supply and Consumption	PoE Out standard	PoE/PoE+/PoE++ (IEEE 802.3af/at/bt)
	Number of PoE/PoE+ Out ports	8
	Number of PoE/PoE+/PoE++ Out ports	1
	PoE budget per port	<ul style="list-style-type: none"> ● Port 1: 90 W ● Ports 2–8: 30W
	PoE budget	<ul style="list-style-type: none"> ● Default: 228 W ● MAX: 300 W (web reserved adjustable interface)
	PoE power pins	<ul style="list-style-type: none"> ● Port 1: 1–2 (-), 3–6 (+), 4–5 (+), 7–8 (-) ● Ports 2–8: 1–2 (+), 3–6 (-)
	Power input	<p>DC input:</p> <ul style="list-style-type: none"> ● Rated voltage range: 46 V DC to 57 V DC ● Rated current range: 7 A <p>RG-NIS-PA240-48 (AC input):</p> <ul style="list-style-type: none"> ● Rated input voltage: 100 V AC to 240 V AC, 50/60 Hz

		<ul style="list-style-type: none"> ● Maximum input voltage: 90 V AC to 264 V AC, 47 Hz to 63 Hz ● Rated input current: 3.5 A <p>Output:</p> <ul style="list-style-type: none"> ● Rated output voltage: 54 V DC ● Maximum output current: 4.4 A <p>RG-NIS-PA120-48 (AC input):</p> <ul style="list-style-type: none"> ● Rated input voltage: 100 V AC to 240 V AC, 50/60 Hz ● Maximum input voltage: 85 V AC to 264 V AC, 47 Hz to 63 Hz ● Rated input current: 1.5 A <p>Output:</p> <ul style="list-style-type: none"> ● Rated output voltage: 48 V DC ● Maximum output current: 2.5 A
	Maximum power consumption	<ul style="list-style-type: none"> ● 12 W (with no PoE load) ● 312 W (with PoE full load)
	Power supply	<ul style="list-style-type: none"> ● DC power adapter ● Power module
Dimensions and Weight	Casing	Metal
	Product dimensions (W x D x H)	50 mm x 155 mm x 130 mm (1.97 in. x 6.10 in. x 5.12 in.)
	Weight	<ul style="list-style-type: none"> ● 0.79 kg (1.74 lbs) (without packaging materials) ● 1.10 kg (2.43 lbs) (with packaging materials)
Environment and Reliability	Fan	Fanless design
	Cooling	Natural cooling
	Mounting options	DIN rail mount/Wall
	Hot swapping of cables	Hot swapping supported by the service port and power connector
	MTBF	200,000 hours
	Operating temperature	-40°C to +75°C (-40°F to +167°F)
	Storage temperature	-40°C to +85°C (-40°F to +185°F)
	Operating humidity	10% RH to 90% RH (non-condensing)
	Storage humidity	5% RH to 95% RH (non-condensing)

	Altitude	-500 m to +5,000 m (-1,640.42 ft. to +16,404.20 ft.)
	Corrosion class	Salt Tolerance
	ESD protection	<ul style="list-style-type: none"> ● Air discharge: 15 kV ● Contact discharge: 8 kV
	Surge protection	<ul style="list-style-type: none"> ● Service port: ±6 kV for common mode ● Power connector: ±4 kV for common mode and ±2 kV for differential mode
	Ground Leakage Current	≤ 3.5 mA
Certification and Regulatory Compliance	EMC	IEC/EN 61000-4-2 IEC/EN 61000-4-3 IEC/EN 61000-4-4 IEC/EN 61000-4-5 IEC/EN 61000-4-6 IEC/EN 61000-4-8
	Safety compliance	EN 62638-1
	Certification	CE, FCC
Interface	EEE	Yes

 **Warning**

Operation of this equipment in a residential environment could cause radio interference.

 **Notes**

Before using long-distance transmission, the following requirements must be met.

1. A CAT5e or better Ethernet cable must be used, with an impedance of less than 25 ohms over a 100-meter (328.08-foot) length.
2. The connected device also supports long-distance transmission.
3. The supply voltage should be 54 V.S
4. After long-distance transmission is enabled on a port with PoE Out supported, its rate will decrease to 10 Mbps. In addition, the cable material, powered device performance, ambient temperature, and other factors will affect the actual transmission distance.

1.4 RG-NIS2100-4GT2SFP-HP

1.4.1 Product Appearance

The RG-NIS2100-4GT2SFP-HP full Gigabit Ethernet switch provides four RJ45 ports supporting 10/100/1000BASE-T auto-negotiation, and two 1000Base-X SFP ports on the front panel. On the top panel, there are one dual-output DC power connector, one DIP switch, one reset button, and one grounding screw.

The product appearance is as follows.

Figure 1-6 Appearance of the RG-NIS2100-4GT2SFP-HP



1. Front Panel

Figure 1-7 Front Panel of the RG-NIS2100-4GT2SFP-HP

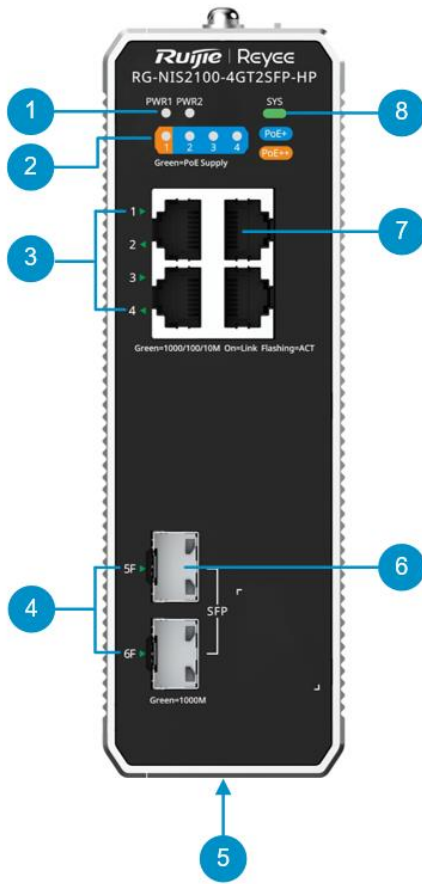

Table 1-8 Front Panel

Number	Item	Description
1	PWR LED	<ul style="list-style-type: none"> ● Off: The power supply is disabled. ● On: The power supply is enabled.
2	PoE status LED	<ul style="list-style-type: none"> ● Off: PoE is disabled. ● Solid green: PoE is enabled.
3	Electrical port status LED	<ul style="list-style-type: none"> ● Off: The port is not connected. ● Solid green: The port operates at 1000/100/10 Mbps and no data is transmitted. ● Blinking green: The port operates at 1000/100/10 Mbps and is transmitting data. (Note: Port 1 is IEEE 802.3bt-compliant.)
4	Optical port status LED	<ul style="list-style-type: none"> ● Off: The port is not connected. ● Solid green: The port operates at 1000 Mbps and no data is transmitted. ● Blinking green: The port operates at 1000 Mbps and is transmitting data.

Number	Item	Description
5	Nameplate	Nameplate on the bottom of the device
6	1000BASE-X SFP ports	SFP port for SFP module expansion
7	10/100/1000BASE-T Ethernet port with auto-negotiation	RJ45 electrical port that connects to a CAT5e network cable
8	System status LED	<ul style="list-style-type: none"> ● Off: The switch is not powered on. ● Fast blinking green (8 to 10 Hz): The switch is starting up. ● Solid green: The switch is operating normally after startup. ● Slow blinking green (0.5 Hz): The switch is operating normally after startup but does not connect to Ruijie Cloud. ● Blinking green (2 Hz): The system is restoring factory settings or upgrading.

2. Top Panel

Figure 1-8 Top Panel of the RG-NIS2100-4GT2SFP-HP

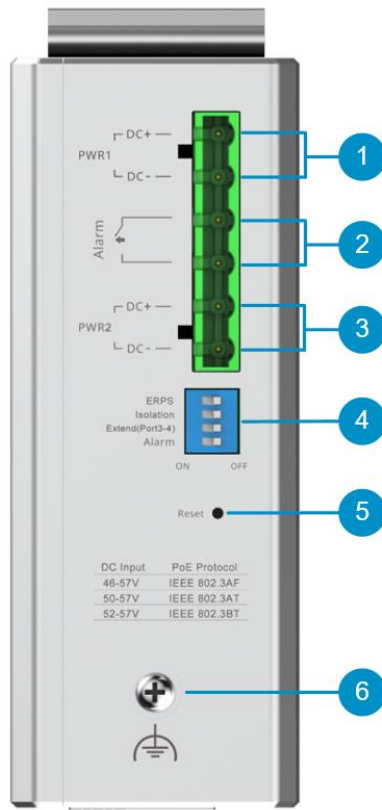

Table 1-9 Top Panel

Number	Item	Description
1	PWR1 DC power connector	Connects to a DC power supply
2	Alarm port	<ul style="list-style-type: none"> ● In normal cases, the contact of an alarm port is closed. ● When an alarm is triggered (by power failure of a power supply), the contact is opened.
3	PWR2 DC power connector	Connects to a DC power supply
4	DIP switch	<ul style="list-style-type: none"> ● ERPS: <ul style="list-style-type: none"> ○ On: Ethernet Ring Protection Switching (ERPS) is enabled. ○ Off: ERPS is disabled. ● Isolation: <ul style="list-style-type: none"> ○ On: Ports 1–4 cannot communicate with each other, but can communicate with ports 5 and 6. Ports 5 and 6 can communicate with each other. ○ Off: Port isolation is disabled. ● Extend(Port3–4): Sets the rate of ports 3–4 to 10 Mbps. ● Alarm: Generates an alarm when the power module is not detected. When the switch is turned off, the alarm function is disabled.
5	Reset button	<ul style="list-style-type: none"> ● Press and hold the button for shorter than two seconds to restart the system. ● Press and hold the button for longer than five seconds until the system status LED starts blinking to restore the web password to the default setting. After saving user configurations, the system restores the factory setting and restarts. ● If the button is pressed and held for two to five seconds, no operation is triggered.
6	Grounding screw	Connects to the ground.

 Note

ERPS, port isolation, and extension mode can be configured through the DIP switch on the device panel or on Eweb. The new configuration will overwrite the old configuration.

3. Rear Panel

Figure 1-9 Rear Panel of the RG-NIS2100-4GT2SFP-HP

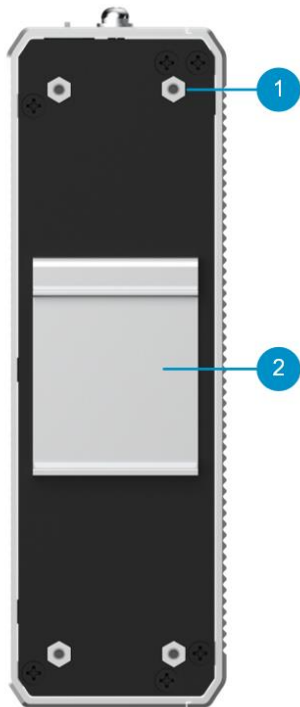

Table 1-10 Rear Panel

Number	Item	Description
1	Mounting bracket screw hole	Used to install mounting brackets
2	DIN rail clamp	Used to secure the switch to the guide rail.

i Note

When mounting the switch on a wall, secure the two screws removed from the DIN rail clamp back into their original holes to guarantee the IP40 protection level of the switch.

4. Bottom Panel

Figure 1-10 Bottom Panel of the RG-NIS2100-4GT2SFP-HP

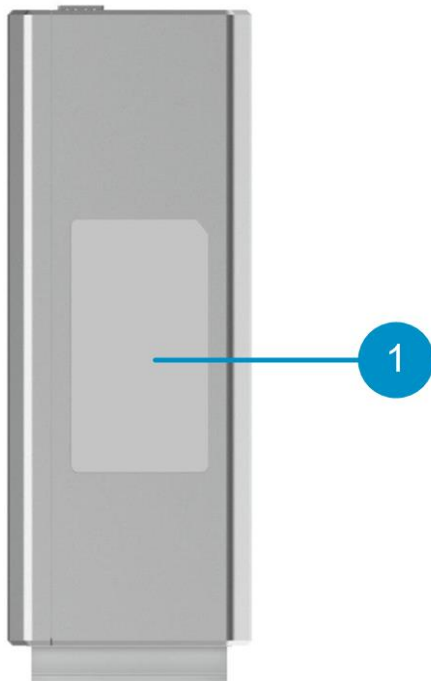

Table 1-11 Bottom Panel

Number	Item	Description
1	Nameplate	Nameplate on the bottom of the device

1.4.2 Technical Specifications

Table 1-12 Technical Specifications of the RG-NIS2100-4GT2SFP-HP

System Specifications	Flash memory	8 MB
	Forwarding rate	8.9 Mpps
	Switching capacity	12 Gbps(bit/s)
Port Specifications	Total number of RJ45 ports	4
	Total number of optical ports	2
	Number of 1GE SFP ports	2
	Number of 10/100/1000BASE-T ports	4

	Long-distance transmission	<p>Yes (ports 3–4)</p> <p>Notes:</p> <ul style="list-style-type: none"> ● Support a stable transmission distance of up to 200 m (656.17 ft.). In a lab environment, with CAT5e or better Ethernet cables, the transmission distance can reach up to 250 m (820.21 ft.). ● Refer to the note below the specifications table for other restrictions on the long-distance transmission feature.
	Reset button	1
	DIP switch	<ul style="list-style-type: none"> ● ERPS mode: Enable ERPS ring network ● Isolation mode: Upper port and lower port isolation ● Extend mode: The rate of Ports 3 to 4 is reduced to 10 Mbps, but the maximum transmission distance can be up to 200 meters (Cat5e cables required) ● Alarm mode: Turn on power in-position detection alarm
	Supported Optical Module Models	For details, see 6.2 SFP Module . Copper cables are not supported.
Power Supply and Consumption	PoE Out standard	PoE/PoE+/PoE++ (IEEE 802.3af/at/bt)
	Number of PoE/PoE+ Out ports	4
	Number of PoE/PoE+/PoE++ Out ports	1
	PoE budget per port	<ul style="list-style-type: none"> ● Port 1: 90 W ● Ports 2–4: 30 W
	PoE budget	<ul style="list-style-type: none"> ● Default: 108 W ● MAX: 180 W (web reserved adjustable interface)
	PoE power pins	<ul style="list-style-type: none"> ● Port 1: 1–2 (-), 3–6 (+), 4–5 (+), 7–8 (-) ● Ports 2–4: 1–2 (+), 3–6 (-)
	Power input	<p>DC input:</p> <ul style="list-style-type: none"> ● Rated voltage range: 46 V DC to 57 V DC ● Rated current range: 4.2 A <p>RG-NIS-PA240-48 (AC input):</p> <ul style="list-style-type: none"> ● Rated input voltage: 100 V AC to 240 V AC, 50/60 Hz ● Maximum input voltage: 90 V AC to 264 V AC, 47 Hz to 63 Hz ● Rated input current: 3.5 A

		<p>Output:</p> <ul style="list-style-type: none"> ● Rated output voltage: 54 V DC ● Maximum output current: 4.4 A <p>RG-NIS-PA120-48 (AC input):</p> <ul style="list-style-type: none"> ● Rated input voltage: 100 V AC to 240 V AC, 50/60 Hz ● Maximum input voltage: 85 V AC to 264 V AC, 47 Hz to 63 Hz ● Rated input current: 1.5 A <p>Output:</p> <ul style="list-style-type: none"> ● Rated output voltage: 48 V DC ● Maximum output current: 2.5 A
	Maximum power consumption	<ul style="list-style-type: none"> ● 12 W (with no PoE load) ● 192 W (with PoE full load)
	Power supply	<ul style="list-style-type: none"> ● DC power adapter ● Power module
Dimensions and Weight	Casing	Metal
	Product dimensions (W x D x H)	50 mm x 155 mm x 130 mm (1.97 in. x 6.10 in. x 5.12 in.)
	Weight	<ul style="list-style-type: none"> ● 0.77 kg (1.70 lbs) (without packaging materials) ● 1.08 kg (2.38 lbs) (with packaging materials)
Environment and Reliability	Fan	Fanless design
	Cooling	Natural cooling
	Mounting options	DIN rail mount/Wall
	Hot swapping of cables	Hot swapping supported by the service port and power connector
	MTBF	200,000 hours
	Operating temperature	-40°C to +75°C (-40°F to +167°F)
	Storage temperature	-40°C to +85°C (-40°F to +185°F)
	Operating humidity	10% RH to 90% RH (non-condensing)
	Storage humidity	5% RH to 95% RH (non-condensing)
Altitude	-500 m to +5,000 m (-1,640.42 ft. to +16,404.20 ft.)	

	Corrosion class	Salt Tolerance
	ESD protection	<ul style="list-style-type: none"> ● Air discharge: 15 kV ● Contact discharge: 8 kV
	Surge protection	<ul style="list-style-type: none"> ● Service port: ±6 kV for common mode ● Power connector: ±4 kV for common mode and ±2 kV for differential mode
	Ground Leakage Current	≤ 3.5 mA
Certification and Regulatory Compliance	EMC	IEC/EN 61000-4-2 IEC/EN 61000-4-3 IEC/EN 61000-4-4 IEC/EN 61000-4-5 IEC/EN 61000-4-6 IEC/EN 61000-4-8
	Safety compliance	EN 62638-1
	Certification	CE, FCC
Interface	EEE	Yes

 **Warning**

Operation of this equipment in a residential environment could cause radio interference.

 **Notes**

Before using long-distance transmission, the following requirements must be met.

1. A CAT5e or better Ethernet cable must be used, with an impedance of less than 25 ohms over a 100-meter (328.08-foot) length.
2. The connected device also supports long-distance transmission.
3. The supply voltage should be 54 V.
4. After long-distance transmission is enabled on a port with PoE Out supported, its rate will decrease to 10 Mbps. In addition, the cable material, powered device performance, ambient temperature, and other factors will affect the actual transmission distance.

2 Preparing for Installation

2.1 Safety Precautions

 Caution

- To avoid personal injury and device damage, please read the safety precautions carefully before installing the device.
 - The following safety precautions may not cover all possible dangers.
-

2.1.1 General Safety

- Keep the chassis clean and dust-free.
- Do not place the device in walking areas.
- During installation and maintenance, do not wear loose clothes, ornaments, or any other things that may be hooked by the chassis.
- Cut off all the power supplies and unplug all power cords before mounting the device in a rack or removing the device from a rack.

2.1.2 Handling Safety

- Avoid handling the device frequently.
- Keep balance and prevent personal injuries when handling the device.
- Cut off all the power supplies and unplug all power cords before moving or handling the switch.

2.1.3 Electric Safety

 Warning

- Improper or incorrect electric operations may cause a fire, electric shock, and other accidents, and lead to severe and fatal personal injury and device damage.
 - Direct or indirect touch through a wet object on high-voltage or mains power supply may be fatal.
-

- Observe local regulations and specifications during electric operations. Only personnel with relevant qualifications can perform such operations.
- Do not maintain the device by yourself when the device is powered on.
- Make sure that the switch is powered off when you cut off the power supply.
- Before installing the device, check potential risks in the work area, such as ungrounded power socket and wet floor.
- Find out the position of the indoor emergency power switch before installation. Cut off the power supply in case of accidents.
- Do not place the switch in a wet position, and keep the switch away from liquid.
- Equip the power supply system with a leakage protector (also referred to as leakage current switch or leakage

current breaker) to automatically cut off the power in case of power leakage or shock. When selecting the leakage protector, observe the following rules:

- The rated leakage action current of each leakage protector must be larger than twice the theoretical maximum leakage current of all the power supplies in the system.

For example, if a system is equipped with 16 identical power supplies and the leakage current of each power supply is equal to or smaller than 3.5 mA, the leakage current of the system totals 56 mA. A leakage protector with 30 mA rated action current supports a maximum of four power supplies (that is, Rated action current of the leakage protector/2/Maximum leakage current of each power supply = $30/2/3.5 \approx 4.28$). In this case, the 16 power supplies in the system require at least four leakage protectors with 30 mA rated action current and each leakage protector supports four power supplies.

If power supplies in a system differ in models, the rated leakage action current of each leakage protector divided by two must be larger than the sum of maximum leakage currents of all the power supplies.

- The rated leakage non-action current of a leakage protector shall be 50% of the rated leakage action current. If the rated leakage non-action current is too small, the leakage protector may be highly sensitive and trip unnecessarily on a normal leakage current, causing device power-off and service interruption.

For instance, the rated leakage non-action current of a leakage protector with 30 mA rated action current of shall be 15 mA. In this case, the leakage protector will not trip when the leakage current is smaller than 15 mA.

 Caution

- To guarantee personal safety, the rated leakage action current of each leakage protector in the system must be equal to or smaller than 30 mA, the amount of current that a person can tolerate. When twice of the total leakage current of the system is larger than 30 mA, the system must be equipped with two or more leakage protectors.
 - For the leakage current value of each power supply model, see the technical specifications in [1 Product Overview](#).
-

2.1.4 Electrostatic Discharge Safety

- Ensure that the grounding screw on the side panel of the device is grounded.
- Keep the indoor installation environment clean and free of dust.
- Keep the indoor humidity within the required range.

2.1.5 Laser Safety

A device with an optical port usually supports multiple types of optical transceivers, all of which are Class I laser products. Pay attention to the following during the use of optical transceivers:

- When an optical transceiver is in operation, ensure that its port is connected to an optical fiber or covered by a dust cap to keep out dust and prevent it from burning your eyes.
- When an optical transceiver is in operation, do not look into its port after removing the optical fiber. Doing so may result in eye injury.

Figure 2-1 Laser Product Warning

! Warning

Do not approach or look directly into any optical port under any circumstances. This may cause permanent damage to your eyes.

2.2 Installation Environment Requirements

To ensure the normal running and prolonged service life of the device, the installation site must meet the following requirements.

2.2.1 Bearing

Evaluate the weight of the device and its accessories, including the cabinet, chassis, and power module, and ensure that the installation site can bear the weight.

2.2.2 Clearance

- To have sufficient room for chassis handling and module swapping, you are advised to maintain an indoor pathway of at least 0.8 m (31.50 in.) wide.
- Maintain a minimum clearance of 0.4 m (15.75 in.) around the device for heat dissipation and device maintenance.

2.2.3 Temperature and Humidity

To ensure the normal operation and prolonged service life of the device, maintain an appropriate temperature and humidity in the equipment room.

Working in an environment with too high or too low temperature and humidity for a long period may damage the device.

- In an environment with high relative humidity, the insulating material may have poor insulation or even leak electricity.
- In an environment with low relative humidity, the insulating strip may dry and shrink, resulting in screw loosening.
- In a dry environment, the internal circuits are prone to static electricity.
- A high temperature can accelerate the aging process of insulating materials, greatly reducing the reliability of the device and severely affecting its service life.

The following table describes the temperature and humidity requirements for the RG-NIS2100 series switches.

Table 2-1 Requirements for Temperature and Humidity

Temperature	Relative Humidity
-40°C to +75°C (-40°F to +167°F)	5% to 95%

 Note

The operating temperature and humidity of the device are measured at the point that is 1.5 m (4.92 ft.) above the floor and 0.4 m (1.31 ft.) before the device when there is no protective plate in front or at the back of the device.

2.2.4 Cleanliness

Dust poses a serious threat to device operation. Dust that falls onto the surface of the device can be absorbed onto metal contact points by static electricity, resulting in poor contact. Electrostatic absorption of dust occurs more easily when the relative humidity is low, which may shorten the service life of the device and cause communication failures. Table 2-2 shows the maximum concentration and diameter of dust allowed in the equipment room.

Table 2-2 Requirements for Dust

Dust	Unit	Maximum Quantity
Dust particles (diameter $\geq 0.5 \mu\text{m}$)	Particles/ m^3	$\leq 3.5 \times 10^6$
Dust particles (diameter $\geq 5 \mu\text{m}$)	Particles/ m^3	$\leq 3 \times 10^4$

Besides, the contents of salts, acids and sulfides in the air are also strictly limited for the equipment room. These substances can accelerate metal corrosion and the aging of some parts. These substances can accelerate metal corrosion and the aging of some parts. Table 2-3 describes the limit of some hazardous gases such as SO_2 , H_2S , NO_2 and Cl_2 in the equipment room.

Table 2-3 Requirements for Gases

Gas	Average (mg/m^3)	Maximum (mg/m^3)
Sulfur dioxide (SO_2)	0.3	1.0
Hydrogen sulfide (H_2S)	0.1	0.5
Nitrogen dioxide (NO_2)	0.5	1.0
Chlorine gas (Cl_2)	0.1	0.3

 Note

Average refers to the average value of harmful gases measured in one week. Maximum refers to the upper limit of the harmful gas measured in one week for up to 30 minutes every day.

2.2.5 Anti-Interference

The device is susceptible to external interference such as capacitive coupling, inductive coupling, electromagnetic waves, common impedance (grounding) coupling, or conduction over conducting wires including power cords, signal cables, and output cables.

- In a TN earthing system, use a 3-wire single-phase outlet that has a protective earth (PE) contact to allow the filter circuit in the device to eliminate interference from the power grid.
- Keep the device away from high-power radio transmitters, radar transmitters, and high-frequency high-current devices.
- Use electromagnetic interference (EMI) shielding such as shielded interface cables to minimize interference when necessary.
- Route interface cables only indoors to prevent signal ports from getting damaged by overvoltage or overcurrent caused by lightning strikes.

2.2.6 Grounding

A proper grounding system is the basis for stable and reliable running. It is indispensable for lightning protection and interference prevention. Carefully check the grounding conditions at the installation site according to the grounding specifications, and complete grounding properly based on the actual situation.

- Secure Grounding

Ensure that the rack and power distribution device are securely grounded when the device uses the AC power supply. Otherwise, electric shock may occur when the insulation resistance between the power supply inside the device and the chassis becomes small.

 Caution

- The building should provide a protective ground connection to ensure that the device is connected to a protective ground.
 - The O&M personnel should check whether the AC outlet is reliably connected to the protective ground of the building. If not, the O&M personnel should use a protective grounding wire to connect the AC outlet PE terminal to the building protective ground.
 - The power outlet should be installed near the device and easily accessible.
 - During device installation, connect the grounding wire first and disconnect it last.
 - The cross-sectional area of the protective grounding wire should be at least 0.75 mm² (18 AWG).
 - Install the device by using three-core power cords, with a minimum cross-sectional area of 0.75 mm² or 18 AWG per pin.
-

- Lightning Grounding

The lightning protection system of facilities is standalone, and is composed of a lightning rod, a down conductor, and a connector connected to the grounding system. The grounding system is usually used for both power reference grounding and safe grounding of the rack. Lightning grounding is required only for facilities and is not required for the device.

- EMC Grounding

Grounding required for electromagnetic compatibility includes shielded grounding, filter grounding, noise and interference suppression, and level reference, which contribute to the overall grounding requirements.

The resistance of the grounding wire should be smaller than 1 Ohm.

2.2.7 Surge Protection

The device can guard against lightning strikes. As an electrical device, too strong lightning strikes may still damage the device. Take the following surge protection measures:

- Ensure that the grounding wire of the cabinet is in good contact with the ground.
- Ensure that the neutral point of the power socket is in good contact with the ground.
- You are advised to install a power lightning arrester in front of the power input end to enhance surge protection for the power supply.

 Note

- Surge protection sockets are customer-supplied.
 - For details about surge protection sockets, see the related user guide.
-

2.2.8 EMI

All EMI sources, either from outside or inside of the device or application system, affect the device by capacitive coupling, inductive coupling, or electromagnetic waves.

EMI occurs due to radiation or conduction, depending on the transmission path.

When the energy, often RF energy, from a component arrives at a sensitive component through the space, the energy is known as radiated interference. The interference source can be either a part of the interfered system or a completely electrically isolated unit. Conducted interference occurs when interference is transferred from one unit to another through cables which are usually electromagnetic wires or signal cables connecting the source and the sensor. Conducted interference often affects the power supply of the device, but this can be controlled by a filter. Radiated interference may affect any signal path in the device, and is difficult to shield.

To mitigate electromagnetic interference and safeguard the device, the following measures should be taken.

- Interference prevention measures should be taken for the power supply system.
- Keep the grounding device of the device far away from the grounding device and lightning grounding device of the power equipment.
- Keep the device far away from the high-power radio transmitter, radar transmitter, and high-frequency large-current devices.
- Take electromagnetic shielding measures when necessary.

2.3 Tools

Table 2-4 Tools

Common Tools	Phillips screwdriver, slotted screwdriver, related copper and optical cables, cage nuts, diagonal pliers, and cable ties
Special Tools	ESD tools
Meters	Multimeter
Other Devices	PC, display, and keyboard

 Note

The RG-NIS2100 series switches are delivered without a tool kit. You need to prepare the tools listed in the tool table.

3 Installing the Switch

⚠ Caution

Before installing the device, make sure that you have carefully read the requirements described in [2 Preparing for Installation](#).

3.1 Installation Procedure

Figure 3-1 Installation Procedure

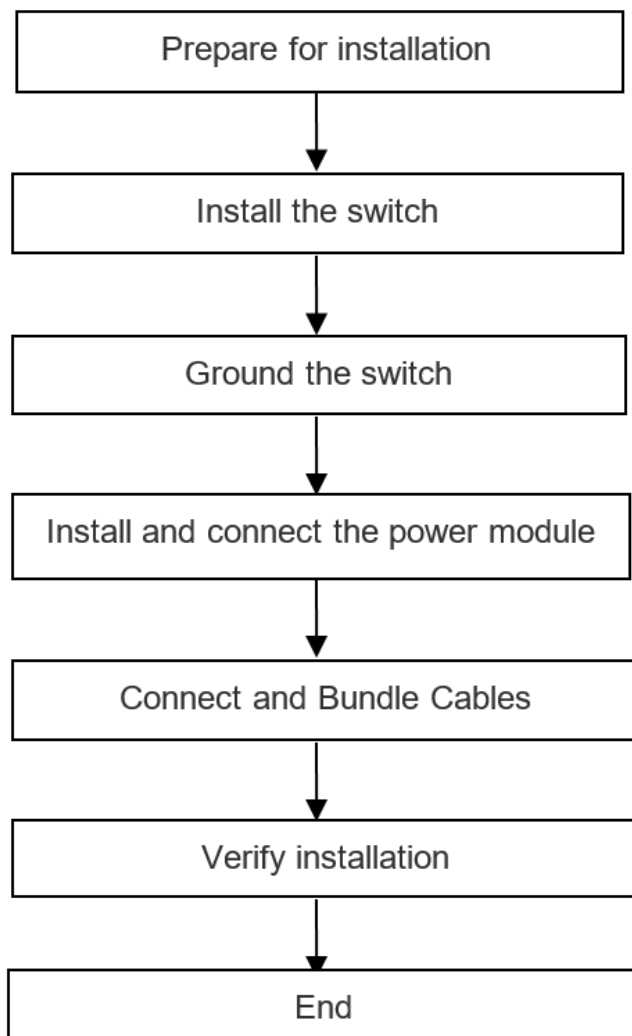

3.2 Before You Begin

Confirm the following requirements before installation:

- The installation environment meets heat dissipation requirements.
- The installation environment meets the temperature and humidity requirements.
- The installation site has a power supply that meets the current requirements.
- The relevant network cables have been arranged at the installation site.

3.3 Precautions

Pay attention to the following:

- Connect the power cords of different colors to the corresponding cable terminals.
- Ensure that the connector of the power cord is properly seated in the power port of the switch. After plugging the power cord into the switch, secure the power cord with power cord retention clip.
- Do not place anything on the top of the switch.
- Maintain a minimum clearance of 0.4 m (15.75 in.) around the device to ensure proper airflow. Do not stack switches.
- Keep the switch away from high-power radio transmitters, radar transmitters, and high-frequency large-current devices. Use EMI shielding such as shielded interface cables to minimize interference when necessary.
- Manage Ethernet cables with a distance of 100 m (328.08 ft.) indoors. Take lightning protection measures if they need to be routed outdoors.

3.4 Installing the Switch

3.4.1 Mounting the Switch on the DIN Rail

The RG-NIS2100 series switches can be mounted on the DIN rail. The installation steps are as follows:

- (1) Position the switch with the DIN rail bracket on the rear facing the DIN rail.

Figure 3-2 Mounting Procedure

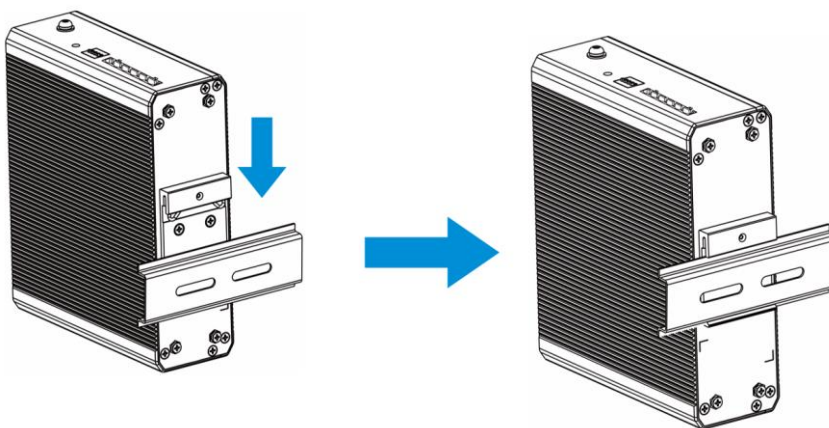

- (2) Engage the DIN rail bracket with the top section of the DIN rail, and then rotate the device so that the bottom hook of the DIN clip clamps to the bottom section of the DIN rail.

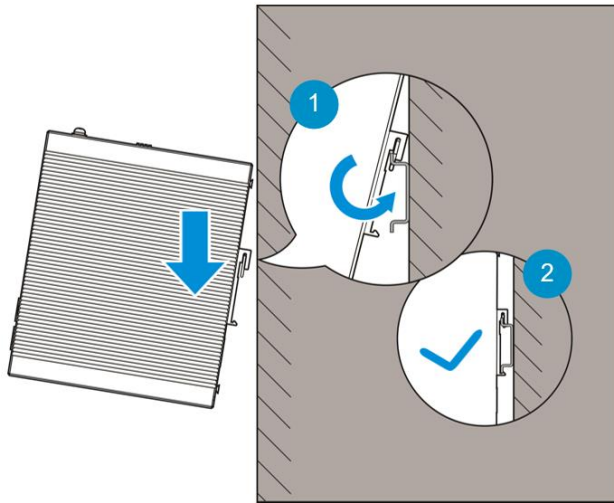
Figure 3-3 Mounting Details

3.4.2 Mounting the Switch on the Wall

⚠ Caution

- Mount the device on a concrete or non-flammable wall.
- You need to prepare four screws and four expansion tubes of appropriate sizes to secure the device.

The RG-NIS2100 series switches can be mounted on a wall using the mounting brackets delivered with the device. The installation steps are as follows:

- (1) Remove the two screws securing the DIN slot, and then remove the DIN slot.
- (2) Secure the two removed screws back into place.
- (3) Use the four M3 x 5 mm screws in the accessory package to secure the mounting brackets to the back of the switch.

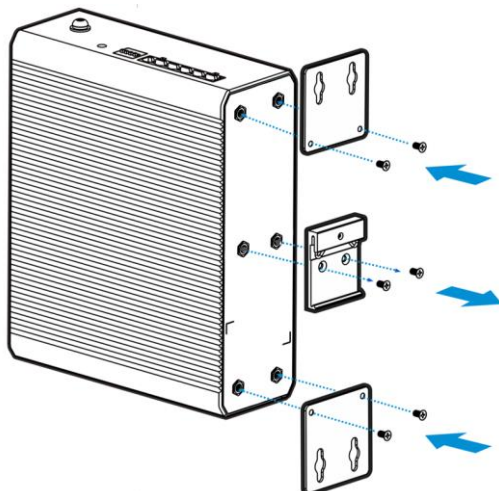
Figure 3-4 Removing the DIN Rail Bracket and Securing the Mounting Brackets

- Use a hammer drill to drill four holes (two on the top and two on the bottom) on the wall, and secure the switch to the wall using four expansion screws.

Note

The distances between holes are shown in the following figure. The hole diameter and depth depend on the screws and expansion tubes you prepare.

Figure 3-5 Securing the Switch

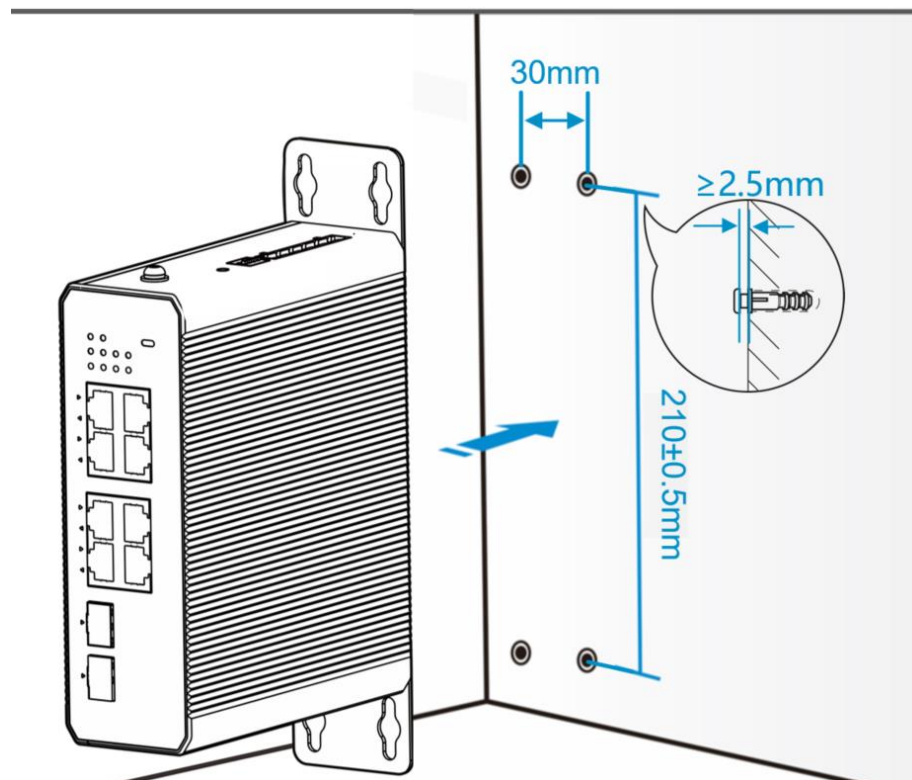

3.5 Grounding the Switch

Note

- If the device is mounted on a wall, connect the grounding stud on the back of the device to the grounding bar in the equipment room.
- The grounding wire of the RG-NIS2100 series switches is not delivered with the device and should be purchased separately.

The switch has a grounding stud on the rear panel. Connect the grounding stud to the grounding point of the rack and then connect the grounding point of the rack to the ground bar of the equipment room.

Precautions:

- The cross-sectional area of a grounding wire should be determined according to the maximum current.

- The grounding wires should be good conductors.
- Do not use bare conductors.
- The resistance between the chassis and ground should be less than 1 ohm.

⚠ Caution

- To avoid personal injury and device damage, connect the switch to earth ground properly.
- The O&M personnel should check whether the AC outlet is reliably connected to the protective ground of the building. If not, the O&M personnel should use a protective grounding wire to connect the AC outlet PE terminal to the building protective ground.
- The power outlet should be installed near the device and easily accessible.
- During device installation, connect the grounding wire first and disconnect it last.
- The cross-sectional area of the protective grounding wire must be at least 0.75 mm² (18 AWG).

3.6 Installing the Power Module

i Note

- This section takes the RG-NIS-PA series power modules as an example. If you purchase a power module of another model, install and connect it to the switch according to the power module description specific to the model.
- Purchase power cords according to the specifications of the switch and power modules. The length of the power cord should be determined based on the actual installation requirements.
- The RG-NIS-PA series power modules can be installed only on DIN rails.

(1) Install the power module.

- Engage the DIN rail bracket of the power module with the top section of the DIN rail.
- Pull down the spring and rotate the device so that the bottom hook of the DIN clip clamps to the bottom section of the DIN rail.

Figure 3-6 Installing the Power Module

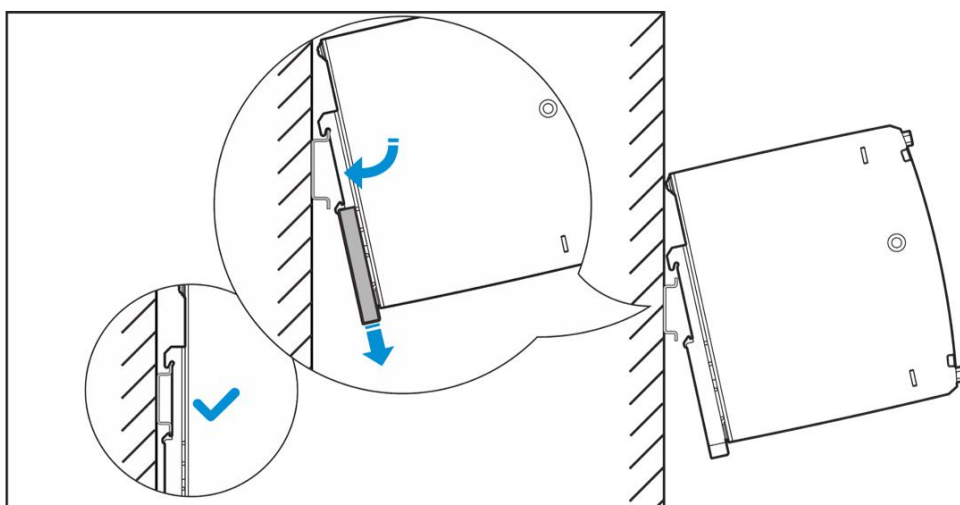

- (2) Connect the power module to the switch according to the following figure:
 - a Connect the power output connector of the power module to the DC power input connector of the switch.
(Ensure that the positions of positive and negative electrodes are correct.)
 - b Connect the power input connector of the power module to the AC grid.

Figure 3-7 Connecting the Power Module to the Switch

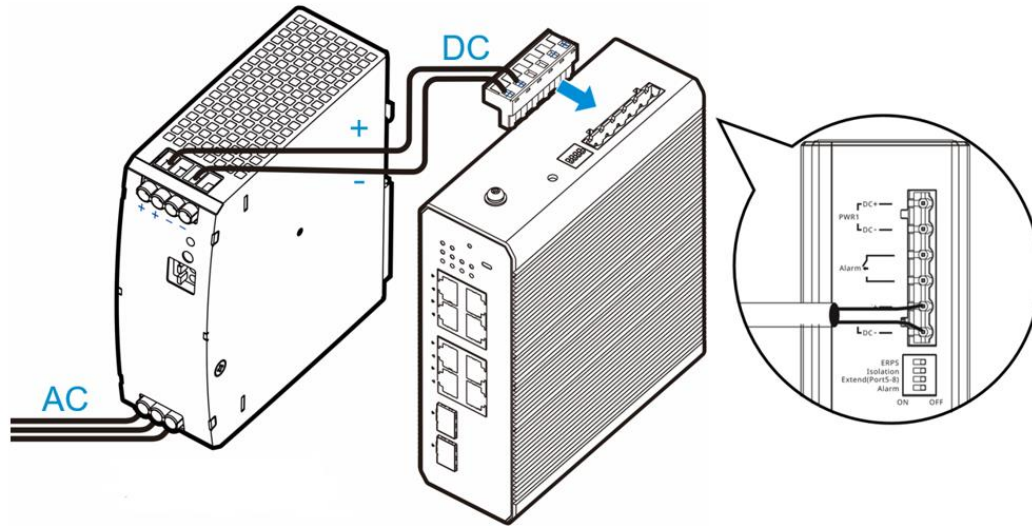

⚠ Caution

When the switch uses the RG-NIS-PA240-48 or RG-NIS-PA120-48 power module and should be IEEE 802.3at/bt-compliant, turn the **ADJ** knob on the power module fully clockwise.

Figure 3-8 ADJ Knob on the Power Module



3.7 Connecting Cables

 Note

- Distinguish single-mode and multi-mode optical cables and interfaces.
 - Avoid a small bend radius at the connector.
-

Connection Procedure

- (1) Connect the RJ45 connector of the Ethernet cable to any electrical port on the front panel of the device, and connect the other end to the network management terminal or control terminal unit.
- (2) Identify the transmit and receive ends of the optical cables, and insert the single-mode or multi-mode optical cables into the corresponding interfaces according to the silkscreen labels.
- (3) Distinguish crossover and straight-through cables, and insert the twisted pair cables with RJ45 connectors into the corresponding interfaces according to the silkscreen labels.

3.8 Bundling the Cables

 Note

- Bundle the power cords and other cables neatly.
 - When bundling optical cables, ensure that they have natural bends or large bend radius at the connectors.
 - Do not bundle optical cables and twisted pairs too tightly, as this may press the cables and affect their service life and transmission performance.
-

Bundling Steps

- (1) Bundle the drooping part of the optical cables and twisted pairs, and route them to both sides of the chassis for convenience.
- (2) On both sides of the chassis, fasten the optical cables and twisted pairs to the cable management bracket or trough.
- (3) For the power cords, bundle them closely along the bottom of the chassis, in a straight line wherever possible.

3.9 Verifying Installation

 Warning

Turn off the power to avoid personal injury and damage to components caused by incorrect connection.

- Verify that the ground wire is connected.
- Verify that the Ethernet cables and power cords are properly connected.
- Verify that the cables with a distance of 100 m (328.08 ft.) are managed indoors. If not, check whether the

power supply and interfaces are protected from lightning strikes.

- Verify that there is a minimum clearance of 0.4 m (15.75 in.) around the switch.

4 Debugging

4.1 Powering On the Switch

(1) Checklist Before Power-On

- The switch is properly grounded.
- The power cord is properly connected.
- The input voltage follows the requirement.
- The Ethernet port on the PC is properly connected to the Ethernet port on the switch. Parameters are set correctly.

(2) Checklist After Power-on

After power-on, you are advised to check the following list to ensure the normal operation of the switch:

- Indicators of the switch are in the normal state.
- Service ports can forward data properly.

4.2 Log In to the Web Interface

- (1) Start up the PC and configure the local connection attribute on the PC. Change the static IP address of the PC to 10.44.77.XXX (1–255, excluding 200).

Figure 4-1 Change the IP Address of the PC

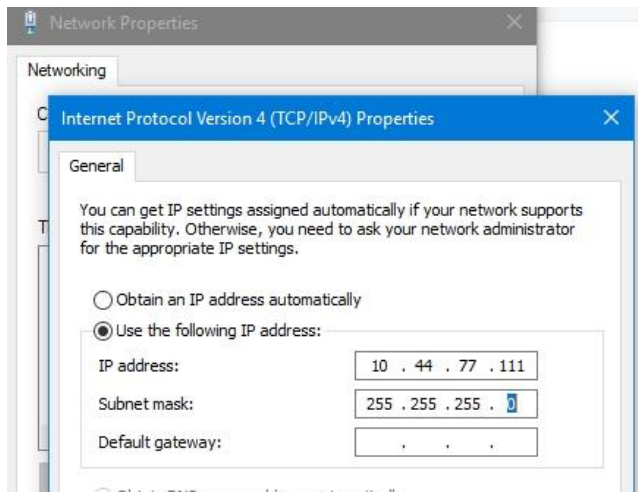

- (2) Open a browser on the PC and enter 10.44.77.200 to log in to the web interface. The default password is "admin" for the first login.

⚠ Caution

To ensure security, you are advised to change the password after login, and update the password regularly.

5 Common Troubleshooting

5.1 Troubleshooting Flowchart

Figure 5-1 Troubleshooting Flowchart

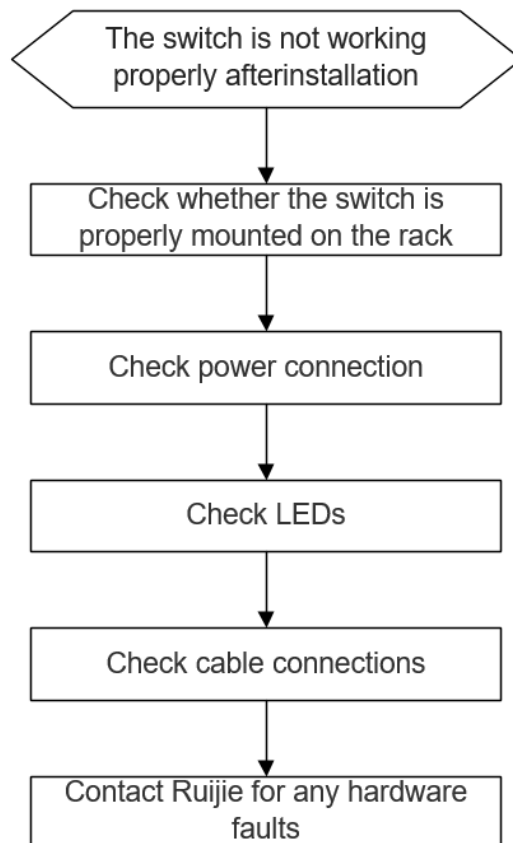

5.2 Common Faults

Table 5-1 Common Faults

Symptom	Possible Cause	Suggested Action
The login password of the web management system is forgotten.	The login password is forgotten after being manually configured.	Press and hold the Reset button to restore the switch to factory settings.

Symptom	Possible Cause	Suggested Action
The SYS LED is off after power on.	No power is supplied to the switch or the power cord is loose.	Check whether the power socket in the equipment room functions normally and whether the power cord connected to the switch is loose.
An RJ45 port is unreachable or a frame sending or receiving error occurs.	<ul style="list-style-type: none"> ● The twisted pair cable is not connected properly. ● The cable length exceeds 100 m (328. 08 ft.). ● The port is specially configured and not in the same working mode as the connected switch. 	<ul style="list-style-type: none"> ● Replace the twisted pair cable. ● Make sure that the port works in the same mode as the connected switch.
An optical port is unreachable.	<ul style="list-style-type: none"> ● The receiving and transmitting ends are connected incorrectly. ● The type of the connected optical module does not match. ● The optical cable does not meet requirements. ● The length of the optical cable is beyond the allowed length marked on the optical module. 	<ul style="list-style-type: none"> ● Exchange the transmitting and receiving ends of the optical cable. ● Replace the optical module with another one of the same type. ● Replace the optical cable with a qualified one. ● Use an optical cable with the required length.

6 Appendix

6.1 Connectors and Media

6.1.1 1000BASE-T/100BASE-TX/10BASE-T Port

The 1000BASE-T/100BASE-TX/10BASE-T is a 10/100/1000 Mbps auto-negotiation port that supports auto MDI/MDIX Crossover.

Compliant with IEEE 802.3ab, 1000BASE-T requires Cat5e 100-ohm UTP or STP (recommended) with a maximum distance of 100 m (328 ft.).

The 1000BASE-T port requires all four pairs of wires to be connected for data transmission. The following Figure shows the connection of twisted pairs used by a 1000BASE-T port.

Figure 6-1 Connections of Four Twisted Pairs for the 1000BASE-T Port

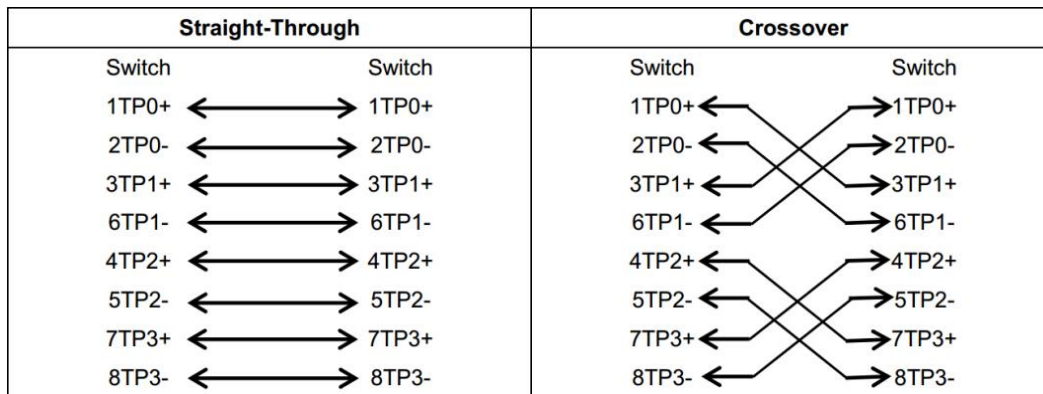

100BASE-TX/10BASE-T can be interconnected using cables of the preceding specifications. For 10 Mbps, the 100BASE-TX/10BASE-T port can be connected using 100-ohm Category 3, Category 4, and Category 5 cables; for 100 Mbps, the 100BASE-TX/10BASE-T port can be connected using 100-ohm Category 5 cables with a maximum connection distance of 100 m (328 ft.). The following table shows 100BASE-TX/10BASE-T pin assignments.

Table 6-1 Pin Assignments for the 100BASE-TX/10BASE-T Port

Pin	Socket	Plug
1	Input Receive Data+	Output Transmit Data+
2	Input Receive Data-	Output Transmit Data-
3	Output Transmit Data+	Input Receive Data+
6	Output Transmit Data-	Input Receive Data-

Pin	Socket	Plug
4, 5, 7, 8	Not Used	Not Used

The following figure shows feasible connections of the straight-through and crossover twisted pairs for a 100BASE-TX/10BASE-T port.

Figure 6-2 Twisted Pair Connections for the 100BASE-TX/10BASE-T Port

Straight-Through		Crossover	
Switch	Adapter	Switch	Switch
1 IRD+ ←	→ 1 OTD+	1 IRD+ ←	→ 1 IRD+
2 IRD- ←	→ 2 OTD-	2 IRD- ←	→ 2 IRD-
3 OTD+ ←	→ 3 IRD+	3 OTD+ ←	→ 3 OTD+
6 OTD- ←	→ 6 IRD-	6 OTD- ←	→ 6 OTD-

6.1.2 Optical Cable Connection

Choose single mode or multi-mode fiber (MMFs) according to the module types.

Figure 6-3 Optical Cable Connection

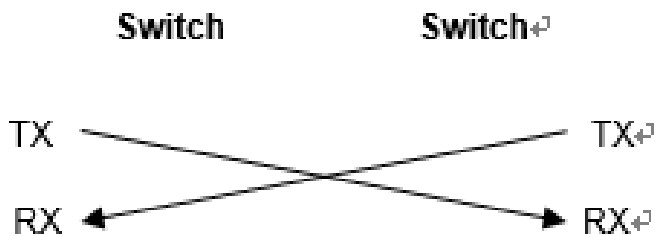

6.2 SFP Modules

We provide appropriate SFP modules according to the port types. You can select a module as required. Besides, the Mini-GBIC-GT modules are also supported. The following models and technical specifications of some SFP modules are listed for your reference. For details about the technical specifications, see *Ruijie Transceiver Installation and Reference Guide*.

Table 6-2 SFP Optical Modules and Technical Specifications (Commercial)

Model	Wavelength (nm)	Fiber Type	Operating Temperature	DDM (Yes/No)	Transmit Power (dBm)		Receive Power (dBm)	
					Min.	Max.	Min.	Max.
MINI-GBIC-SX-MM850	850	MMF	0°C to 70°C (32°F to 158°F)	No	-9.5	-3	-17	0
MINI-GBIC-LX-SM1310	1310	SMF	0°C to 70°C (32°F to 158°F)	No	-9.5	-3	-20	-3
GE-eSFP-SX-MM850	850	MMF	0°C to 70°C (32°F to 158°F)	Yes	-9.5	-3	-17	0
GE-eSFP-LX-SM1310	1310	SMF	0°C to 70°C (32°F to 158°F)	Yes	-9.5	-3	-20	-3
GE-SFP-LX-SM1310	1310	SMF	0°C to 70°C (32°F to 158°F)	No	-9.5	-3	-20	-3
MINI-GBIC-LH40-SM1310	1310	SMF	0°C to 70°C (32°F to 158°F)	Yes	-2	3	-22	-3
GE-SFP-SX-SM1310-BIDI	1310	MMF	0°C to 70°C (32°F to 158°F)	No	-10	-5	-17	-3
GE-SFP-SX-SM1550-BIDI	1550	MMF	0°C to 70°C (32°F to 158°F)	No	-10	-5	-17	-3
GE-SFP-LX20-SM1310-BIDI	1310TX/1550RX	SMF	0°C to 70°C (32°F to 158°F)	Yes	-9	-3	-20	-3
GE-SFP-LX20-SM1550-BIDI	1550TX/1310RX	SMF	0°C to 70°C (32°F to 158°F)	Yes	-9	-3	-20	-3
GE-SFP-LH40-SM1310-BIDI	1310TX/1550RX	SMF	0°C to 70°C (32°F to 158°F)	Yes	-5	0	-24	-1
GE-SFP-LH40-SM1550-BIDI	1550TX/1310RX	SMF	0°C to 70°C (32°F to 158°F)	Yes	-5	0	-24	-1
MINI-GBIC-ZX50-SM1550	1550	SMF	0°C to 70°C (32°F to 158°F)	Yes	-5	0	-22	-3
MINI-GBIC-ZX80-SM1550	1550	SMF	0°C to 70°C (32°F to 158°F)	Yes	0	4.7	-22	-3
MINI-GBIC-ZX100-SM1550	1550	SMF	0°C to 70°C (32°F to 158°F)	Yes	0	5	-30	-9

Model	Wavelength (nm)	Fiber Type	Operating Temperature	DDM (Yes/No)	Transmit Power (dBm)		Receive Power (dBm)	
					Min.	Max.	Min.	Max.
GE-SFP-SX	850	MMF	0°C to 70°C (32°F to 158°F)	No	-9.5	-3	-17	0
GE-SFP-LX	1310	SMF	0°C to 70°C (32°F to 158°F)	No	-9.5	-3	-20	-3
SFP-MM850	850	MMF	0°C to 70°C (32°F to 158°F)	No	-9.5	-3	-17	0
SFP-SM1310	1310	SMF	0°C to 70°C (32°F to 158°F)	No	-9.5	-3	-20	-3

Table 6-3 SFP Optical Modules and Technical Specifications (Industrial)

Model	Wavelength (nm)	Fiber Type	Operating Temperature	DDM (Yes/No)	Transmit Power (dBm)		Receive Power (dBm)	
					Min.	Max.	Min.	Max.
NIS-GE-SFP-10KM-SM1310	1310	SMF	-40°C to 85°C (-40°F to +185°F)	Yes	-9.5	-3	-20	-3
NIS-GE-SFP-20KM-SM1310-BIDI	1310TX/1550RX	SMF	-40°C to 85°C (-40°F to +185°F)	Yes	-9	-3	-22	-3
NIS-GE-SFP-20KM-SM1550-BIDI	1550TX/1310RX	SMF	-40°C to 85°C (-40°F to +185°F)	Yes	-9	-3	-22	-3
NIS-GE-SFP-550M-MM850	850	MMF	-40°C to 85°C (-40°F to +185°F)	Yes	-9.5	-3	-17	0

Table 6-4 1000BASE-T SFP Copper Module

Standard	1000BASE-T SFP Module	DDM (Yes/No)
1000BASE-T	Mini-GBIC-GT	No

Table 6-5 Cabling Specifications of SFP Modules

SFP Model	Connector Type	Fiber type	Core Size (μm)	Max. Cabling Distance
MINI-GBIC-SX-MM850	LC	MMF	62.5/125	275 m (902.23 ft.)
			50/125	550 m (1804.46 ft.)
MINI-GBIC-LX-SM1310	LC	SMF	9/125	10 km (6.21 mi.)
GE-eSFP-SX-MM850	LC	MMF	62.5/125	275 m (902.23 ft.)
			50/125	550 m (1804.46 ft.)
GE-eSFP-LX-SM1310	LC	SMF	9/125	10 km (6.21 mi.)
GE-SFP-LX-SM1310	LC	SMF	9/125	10 km (6.21 mi.)
MINI-GBIC-LH40-SM1310	LC	SMF	9/125	40 km (24.85 mi.)
GE-SFP-SX-SM1310-BIDI	LC	MMF	50/125	500 m (1640.42 ft.)
GE-SFP-SX-SM1550-BIDI	LC	MMF	50/125	500 m (1640.42 ft.)
GE-SFP-LX20-SM1310-BIDI	LC	SMF	9/125	20 km (12.43 mi.)
GE-SFP-LX20-SM1550-BIDI	LC	SMF	9/125	20 km (12.43 mi.)
GE-SFP-LH40-SM1310-BIDI	LC	SMF	9/125	40 km (24.85 mi.)
GE-SFP-LH40-SM1550-BIDI	LC	SMF	9/125	40 km (24.85 mi.)
MINI-GBIC-ZX50-SM1550	LC	SMF	9/125	50 km (31.07 mi.)
MINI-GBIC-ZX80-SM1550	LC	SMF	9/125	80 km (49.71 mi.)
MINI-GBIC-ZX100-SM1550	LC	SMF	9/125	100 km (62.14 mi.)
GE-SFP-SX	LC	MMF	62.5/125	275 m (902.23 ft.)
			50/125	550 m (1804.46 ft.)

SFP Model	Connector Type	Fiber type	Core Size (µm)	Max. Cabling Distance
GE-SFP-LX	LC	SMF	9/125	10 km (6.21 mi.)
Mini-GBIC-GT	RJ45 Ethernet cable	Cat 5 (or higher) twisted pair		100 m (302.08 ft.)

 **Caution**

- For optical modules with a cabling distance of over 40 km (24.85 mi.) (including 40 km) (including 24.85 miles), install an optical attenuator to avoid overload on the optical receiver when using short-distance single-mode fibers (SMFs).
- An optical module is a laser transmitter. Do not look directly into the optical module to prevent it from burning your eyes.
- To keep the optical module clean, ensure that the unused ports remain capped.

Table 6-6 Pairing Models of the BIDI Optical Modules

Speed/Distance	Pairing Model
1GE/500 m	<ul style="list-style-type: none"> ● GE-SFP-SX-SM1310-BIDI ● GE-SFP-SX-SM1550-BIDI
1GE/20 km	<ul style="list-style-type: none"> ● GE-SFP-LX20-SM1310-BIDI ● GE-SFP-LX20-SM1550-BIDI
1GE/40 km	<ul style="list-style-type: none"> ● GE-SFP-LH40-SM1310-BIDI ● GE-SFP-LH40-SM1550-BIDI
10GE/300 m	<ul style="list-style-type: none"> ● XG-SFP-SR-SM1270-BIDI ● XG-SFP-SR-SM1330-BIDI
10GE/10 km	<ul style="list-style-type: none"> ● XG-SFP-LR-SM1270-BIDI ● XG-SFP-LR-SM1330-BIDI

 **Note**

The BIDI modules must be used in pairs. For example, if you install the GE-SFP-LX20-SM1310-BIDI in the local port, you must install the GE-SFP-LX20-SM1550-BIDI in the peer port.

6.3 Surge Protection

6.3.1 Installing an AC Power Arrester (Lightning Resistance Socket)

When an AC power cord is introduced from outdoors and directly connected to the power port of the switch, the AC power port must be connected to an external surge protection power strip to protect the switch against lightning strokes. The lightning resistance socket can be fixed on the rack, workbench, or wall in the equipment

room by using cable ties and screws. AC power enters the surge protection power strip and then enters the switch.

Figure 6-4 Power Arrester

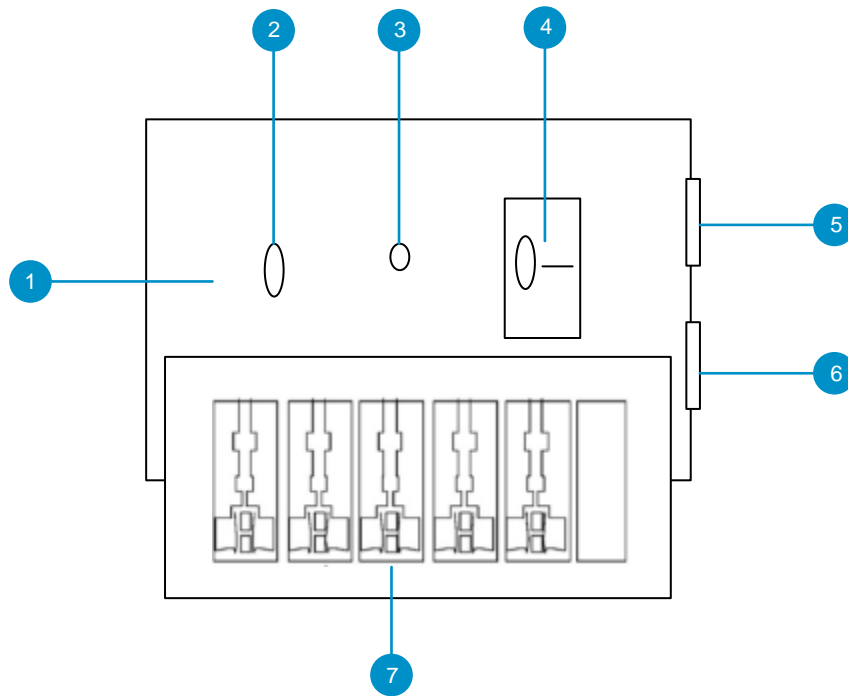

No.	Description
1	Installed electronic circuit board
2	Normally running indicator: When the indicator is green, the circuit is working properly. Otherwise, the protective circuit is damaged.
3	Grounding and polarity detection indicator: If the indicator is red, cable connection is incorrect (the ground cable is not connected, or the N and L lines are reversely connected). Check your power supply line.
4	Power switch
5	IEC standard socket, which is connected to the power supply in the equipment room through the power cable
6	Overload auto-protector, which can be reset manually
7	Multi-purpose sockets (connected to the power supply of the switch)

Note

The power arrester is not delivered with the switch. Please purchase it based on actual requirements.

Important points:

- Make sure that the PE terminal of the power arrester is well grounded.
- After the AC power plug of the switch is connected to the socket of the power arrester (lightning resistance socket), the surge protection function is implemented only if the RUN LED is green and the ALARM LED is off.
- If the ALARM LED on the power arrester is red, check whether it is caused by poor grounding connection or by the reversed connection of the Null and Live lines. The detection method is as follows: Use a multimeter to measure the polarity of the power socket for the arrester when the LED is red. If the N line is on the left and the L line is on the right (facing the socket), the arrester's PE terminal is not grounded. If not, the polarity of the arrester power cord should be reversed. In this case, you should open the power arrester and rectify the polarity of the connection. If the indicator is still red, the arrester's PE terminal is not grounded.

6.3.2 Installing the Ethernet Port Arrester

Connect an Ethernet port arrester to the switch to prevent the damage by lightning before connecting an outdoor network cable to the switch.

Tools: Phillips screwdrivers or flat-head screwdriver, multimeter, and diagonal pliers

Installation Steps:

- (1) Tear one side of the protective paper for the double-sided adhesive tape and paste the tape to the enclosure of the Ethernet port arrester. Tear the other side of the protective paper for the double-sided adhesive tape and paste the Ethernet port arrester to the switch enclosure. The paste position for the Ethernet port arrester should be as close to the grounding terminal of the switch as possible. over any of its shares arising under its Articles of Association;
- (2) According to the distance between the switch grounding terminal and the Ethernet port arrester, cut the grounding cable for the Ethernet port arrester and firmly crimp the grounding cable to the grounding terminal of the switch.
- (3) Use a multimeter to check whether the grounding cable for the arrester is in good contact with the grounding terminal and the enclosure of the switch.
- (4) Connect the arrester by using an adapter cable (note that the external network cable is connected to the IN end, while the adapter cable connected to the switch is connected to the OUT end) and check whether the service module LED is normal.
- (5) Use a nylon cable tie to bind the power cords.

Figure 6-5 Installation of the Ethernet Port Arrester

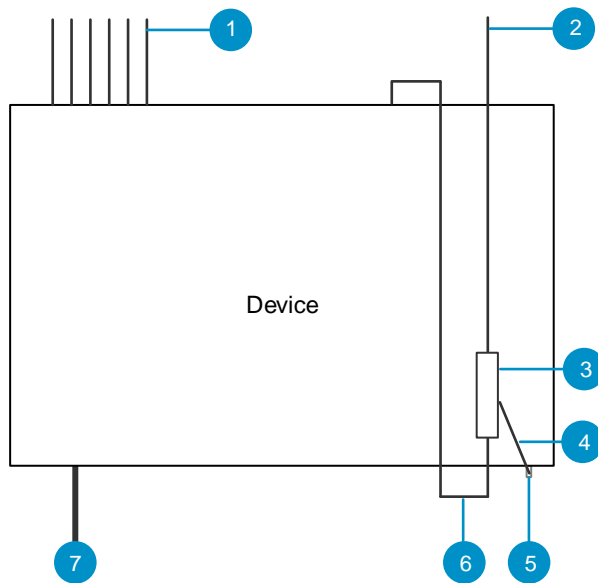

No.	Description
1	Ethernet cable for indoor connection
2	Ethernet cable connected to the outdoor
3	RJ45 port arrester (pasted on the enclosure)
4	Ground cable of the arrester
5	Grounding lug of the equipment
6	RJ45 port adapter cable
7	Power input

⚠ Caution

- The Ethernet port arrester is only for the 10/100 Mbps electrical ports with an RJ45 connector.
- The Ethernet port arrester is not delivered with the switch. Please purchase it based on actual requirements. The Ethernet port arrester user manual contains technical parameters and maintenance and installation instructions for the Ethernet port arrester. Carefully read this manual before installation.

Pay attention to the following situations during the installation to avoid influencing the performance of the Ethernet port arrester:

- Reversed installation direction of the arrester. Connect the external network cable to the "IN" end and connect the Ethernet port of the switch to the "OUT" end.
- Poor grounding of the arrester. The grounding cable of the arrester should be as short as possible to ensure that it is in good contact with the grounding terminal of the switch. Use a multimeter to confirm the contact condition after grounding.

- Incomplete arrester installation. If there is more than one port connected to the peer device on the switch, arresters need to be installed on all connection ports for the purpose of surge protection.

6.4 Cabling Recommendations

6.4.1 Requirements for Cable Bend Radius

- The bend radius of a fixed power cord, network cable, or flat cable should be over five times greater than their respective diameters. The bend radius of these cables that are often bent or plugged should be over seven times greater than their respective diameters.
- The bend radius of a fixed common coaxial cable should be over seven times greater than its diameter. The bend radius of the common coaxial cable that is often bent or plugged should be over 10 times greater than its diameter.
- The bend radius of a fixed high-speed cable (such as SFP+ cable) should be over five times greater than its diameter. The bend radius of the fixed high-speed cable that is often bent or plugged should be over 10 times greater than its diameter.

6.4.2 Requirement for the Minimum Bend Radius of an Optical Cable

- The diameter of a cable tray to hold cables should be over 25 times greater than the diameter of the cable.
- When an optical cable is moved, the bend radius of the cable should be over 20 times greater than the diameter of the fiber.
- During cabling of an optical cable, the bend radius of the cable should be over 10 times greater than the diameter of the fiber.

6.4.3 Precautions for Bundling up Cables

- Before cables are bundled, mark labels and stick the labels to cables wherever appropriate.
- Cables should be neatly and properly bundled in the rack without twisting or bending.

Figure 6-6 Binding Cables (1)

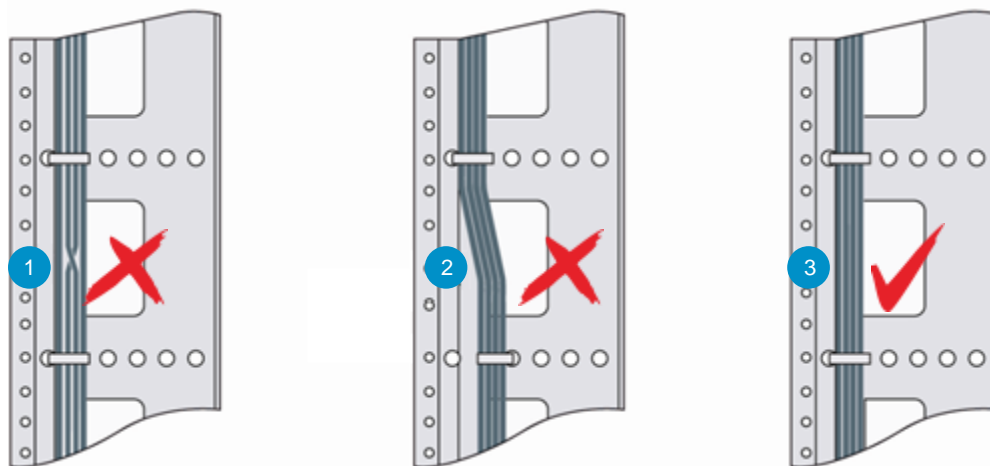

No.	Description
1	In the rack, cables should not be wound up after being bundled.
2	In the rack, cables should not bend after being bundled.
3	In the rack, cables should be neatly and straightly bundled.

- Cables of different types (such as power cords, signal cables, and ground cables) should be separated in cabling and bundling. Mixed bundling is disallowed. When they are close to each other, you are advised to adopt crossover cabling. In the case of parallel cabling, maintain a minimum distance of 30 mm (1.18 in.) between power cords and signal cables.
- The cable management brackets and cabling troughs inside and outside the rack should be smooth without sharp corners.
- The metal hole traversed by cables should have a smooth and fully rounding surface or an insulated lining.
- Use cable ties to bundle up cables properly. Please do not connect two or more cable ties to bundle up cables.
- After bundling up cables with cable ties, cut off the remaining part. The cut should be smooth and trim without sharp corners.

Figure 6-7 Binding Cables (2)

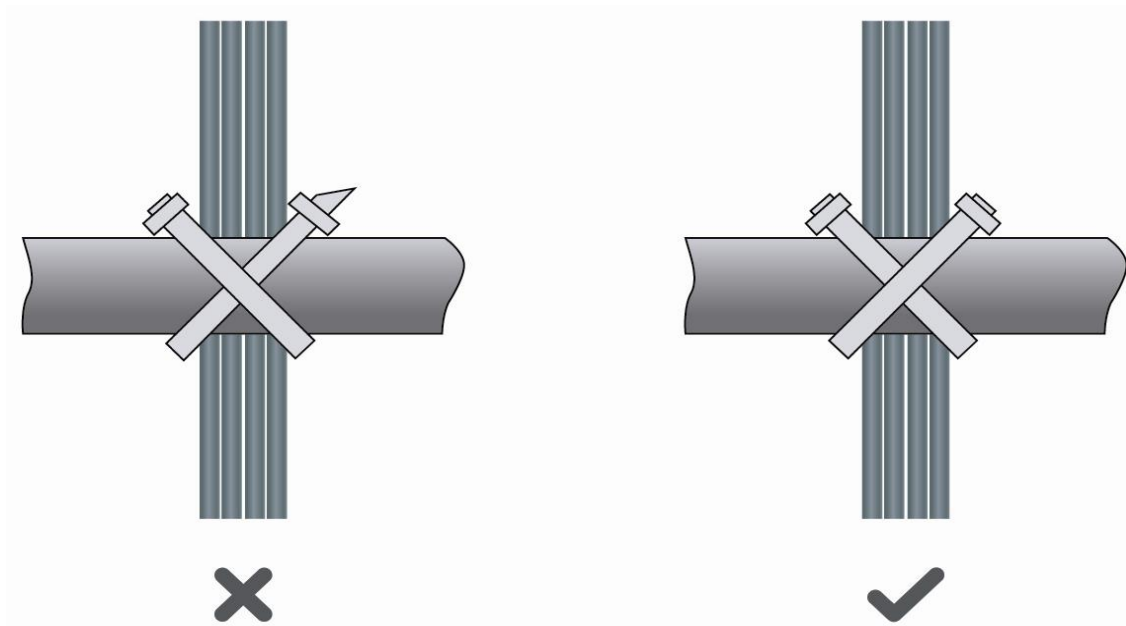

- When cables need to be bent, please bundle them up but do not tie them where the cables will be bent. Otherwise, stress may be generated on the cables, causing the cable cores inside to break.

Figure 6-8 Binding Cables (3)

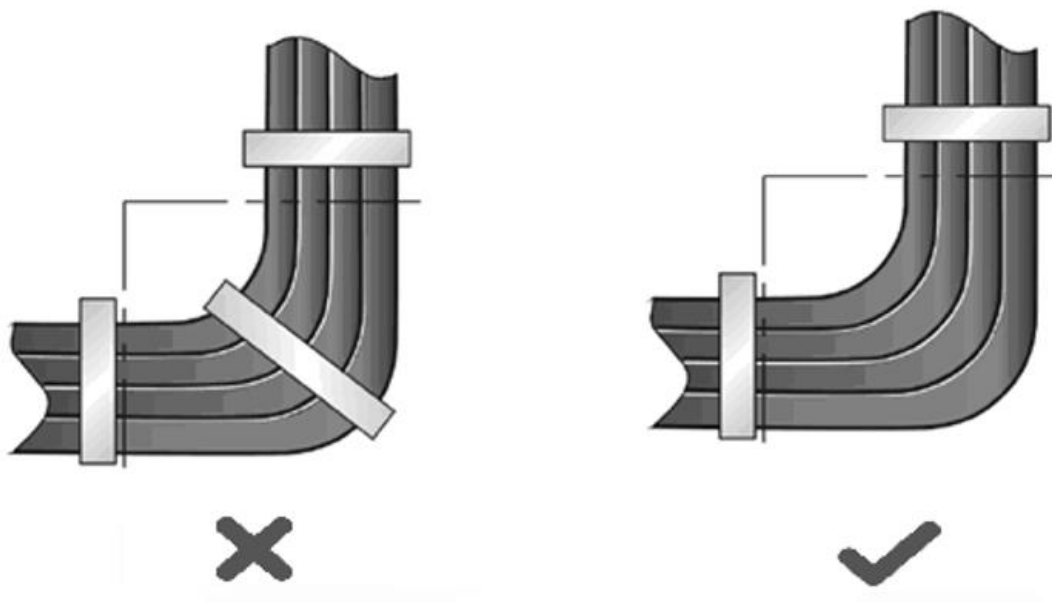

- Cables not to be assembled or remaining parts of cables should be folded and placed in a proper position of the rack or cable trough. The proper position refers to a position that does not affect device running or damage the switch or cable.
- Do not bind power cords to the guide rails of moving parts.
- The power cords connecting moving parts such as door grounding cables should be reserved with some access after being assembled to avoid suffering tension or stress. After the moving part is installed, the remaining cable part should not touch heat sources, sharp corners, or sharp edges. If heat sources cannot be avoided, high-temperature cables should be used.
- When screw threads are used to secure a cable terminal, the bolt or screw must be tightened, and measures should be taken to retain the terminal.

Figure 6-9 Securing Cables

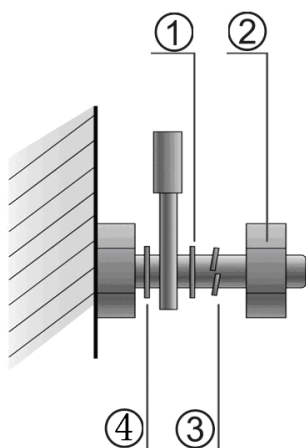

No.	Description
1	Flat washer
2	Screw nut
3	Spring washer
4	Flat washer

- Hard power cords should be fastened in the terminal connection area to prevent stress on terminal connection and cable.
- Do not use self-tapping screws to fasten terminals.
- Power cords of the same type and in the same cabling direction should be bundled up into cable bunches, with cables in cable bunches clean and straight.
- Bundle up cables by using cable ties.

Table 6-7 Requirements for Binding Cables with Cable Ties

Cable Bunch Diameter	Distance Between Every Binding Point
10 mm (0.39 in.)	80 mm to 150 mm (3.15 in. to 5.91 in.)
10 mm to 30 mm (0.39 in. to 1.18 in.)	150 mm to 200 mm (5.91 in. to 7.87 in.)
30 mm (1.18 in.)	200 mm to 300 mm (7.87 in. to 11.81 in.)

- Do not tie cables or bundles in a knot.
- For wiring terminal sockets (such as circuit breakers) with cord end terminals, the metal part of the cord end terminal should not be exposed outside the terminal socket when assembled.

6.5 Equipment Room Site Selection

- The equipment room should be at least 5 km (3.11 mi.) away from heavy pollution sources, such as the smelter works, coal mine, and thermal power plant. The equipment room should be at least 3.7 km (2.30 mi.) away from medium pollution sources, such as the chemical factory, rubber factory, and electroplating factory. The equipment room should be at least 2 km (1.24 mi.) away from light pollution sources, such as the food factory and leather plant. If the pollution source is unavoidable, the equipment room should be located on the windward side of the pollution source perennially with advanced protection.
- The equipment room should be at least 3.7 km (2.30 mi.) away from the sea or salt lake. Otherwise, the equipment room must be sealed, with air conditioner installed for temperature control. Saline soil cannot be used for construction. Otherwise, you should select devices with advanced protection against severe environment.
- Do not build the equipment room in the proximity of livestock farms. Otherwise, the equipment room should be located on the windward side of the pollution source perennially. The previous livestock house or fertilizer warehouse cannot be used as the equipment room.

- The equipment room should be firm enough to withstand severe weather conditions such as windstorm and heavy rain as well as away from dust. If the dust is unavoidable, keep the door and window away from the pollution source.
- The equipment room should be away from the residential area. Otherwise, the equipment room should meet the construction standard in terms of noise.
- Make sure the air vent of the equipment room is away from the sewage pipe, septic tank, and sewage treatment tank. Keep the equipment room under positive pressure to prevent corrosive gas from entering the equipment room to corrode components and circuit boards.
- Keep the equipment room away from industrial boiler and heating boiler.
- The equipment room should be on the second floor. Otherwise, the equipment room floor should be 600 mm (23.62 in.) higher than the highest flood level ever recorded.
- Make sure there are no cracks or holes in the wall and floor. If there are cable entries in the wall or window, take proper sealing measures. Ensure that the wall is flat, wear-resistant, and dust-free, which should be up to the standard for flame retarding, soundproofing, heat absorption, dust reduction, and electromagnetic shielding.
- Keep the door and the window closed to make the equipment room sealed.
- The steel door is recommended for soundproofing.
- Sulfur-containing materials are forbidden.
- Keep the air conditioner from blowing wind straight toward the device or blowing water drops from the window or air vent toward the device.