

VISTA ISOMETRICA

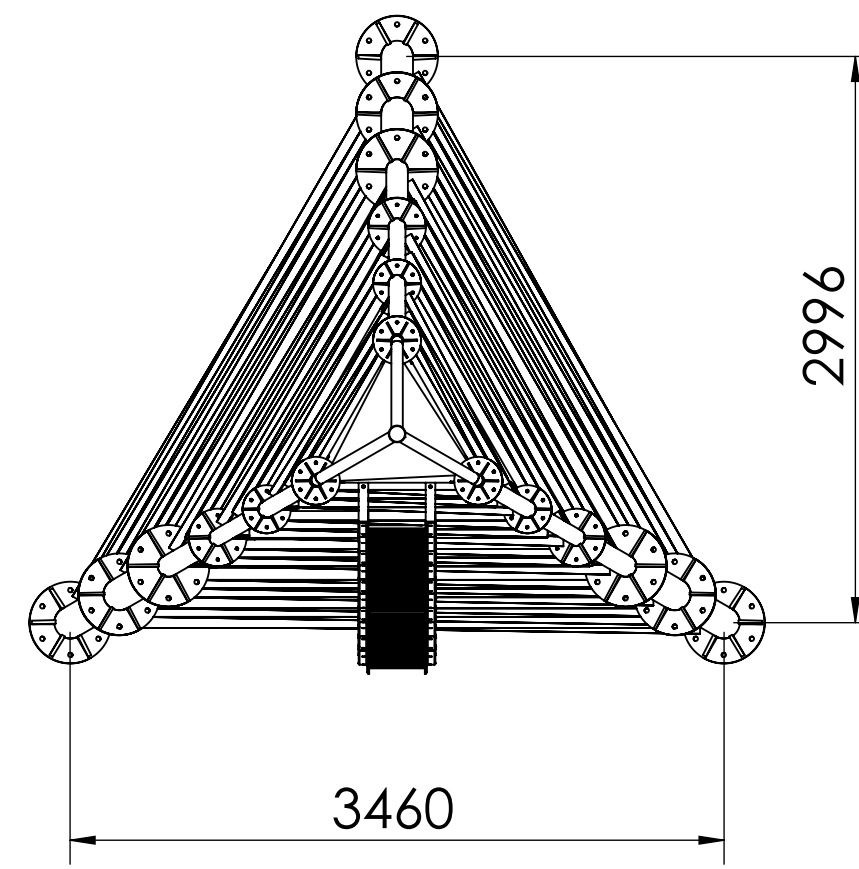

VISTA PLANTA

TORRE 30 M

N.º DE ELEMENTO	N.º DE PIEZA	CANTIDAD	PESO TOTAL KG.
1	Tramo B	1	504
2	Tramo C	1	702
3	Tramo D	1	933
4	Tramo E	1	1,399
5	Tramo F	1	1,479
Peso Total Kg			5,017

LISTA MATERIALES TRAMO

N.º DE ELEMENTO	N.º DE PIEZA	TRAMO TORRE	CANTIDAD
1	TS-02	B	3
2	ARR-03	B	2
3	ARR-04	B	2
4	ARR-05	B	2
5	CV-03	B	6
6	CV-04	B	6
7	CV-05	B	6
8	ARR-03.1	B	1
9	ARR-04.1	B	1
10	ARR-05.1	B	1
11	ES02	B	1
12	ES03	B	1
13	SP-01	B	9
14	TS-03	C	3
15	ARR-06	C	2
16	ARR-07	C	2
17	ARR-08	C	2
18	CV-06	C	6
19	CV-07	C	6
20	CV-08	C	6
21	ARR-06.1	C	1
22	ARR-07.1	C	1
23	ARR-08.1	C	1
24	ES04	C	1
25	ES05	C	1
26	SP-01	C	9
27	TS-04	D	3
28	ARR-09	D	2
29	ARR-10	D	2
30	ARR-11	D	2
31	CV-09	D	6
32	CV-10	D	6
33	CV-11	D	6
34	ARR-09.1	D	1
35	ARR-10.1	D	1
36	ARR-11.1	D	1
37	ES06	D	1
38	ES07	D	1
39	SP-01	D	9
40	TS-05	E	3
41	ARR-12	E	2
42	ARR-13	E	2
43	ARR-14	E	2
44	CV-12	E	6
45	CV-13	E	6
46	CV-14	E	6
47	ARR-12.1	E	1
48	ARR-13.1	E	1
49	ARR-14.1	E	1
50	ES08	E	1
51	ES09	E	1
52	SP-02	E	9
53	TS-06	F	3
54	ARR-15	F	2
55	ARR-16	F	2
56	ARR-17	F	2
57	CV-15	F	6
58	CV-16	F	6
59	CV-17	F	6
60	ARR-15.1	F	1
61	ARR-16.1	F	1
62	ARR-17.1	F	1
63	ES10	F	1
64	ES11	F	1
65	SP-02	F	1

ACABADO <small>* GALVANIZADO POR INMERSION EN CALIENTE (HOT DIP) DE ACUERDO A NORMA. * ASTM-A123 * MNX-H-004-SCFI-2020 TODA LA INFORMACION EMITIDA EN ESTE PLANO ES PROPIEDAD DE INDUSTRIAS METALICAS HALCON QUEDA PROHIBIDA SU REPRODUCCION PARCIAL O TOTAL.</small>	NOTAS GENERALES <small>1. MEDIDAS EN MILIMETROS, EXCEPTO INDICADAS. 2. TOLERANCIA GENERAL +3 MM. 3. TODO MATERIAL ES DE ACERO ASTM A-36. 4. TODA LA SOLDADURA SERA DEL TIPO AWS E7018. 5. LA TORNILLERIA ES GRADO A-325 HOT DIP. 6. DISEÑO CONFORME A NORMA ANSI TIA 222 H</small>	NOMBRE <small>DIBUJO: PEDRO MENDOZA REVISO: ALEJANDRO FRAIRE APROBO: ALEJANDRO FRAIRE EMISION: 15 JULIO 2024</small>	DESCRIPCION PRODUCTO <p style="text-align: center; color: red; font-weight: bold; font-size: 1.2em;">TORRE DE 30 MTS</p>		
		<small>NOMBRE PLANO: TAS-30M REVISION: A</small>			