

Ruijie Cybrex RG-NSEC-SIC-LTE-S Module

Installation Guide

Copyright

Copyright © 2026 Ruijie Networks

All rights are reserved in this document and this statement.

Without the prior written consent of Ruijie Networks, no organization or individual is permitted to reproduce, extract, back up, modify, or distribute the content of this document in any manner or form. It is also prohibited to translate the document into other languages or use any or all parts of it for commercial purposes.



and other Ruijie networks logos are trademarks of Ruijie Networks.

All other trademarks or registered trademarks mentioned in this document are owned by their respective owners.

Disclaimer

The products, services, or features that you purchase are subject to commercial contracts and terms. It is possible that some or all of the products, services, or features described in this document may not be available for purchase or use. Unless agreed upon otherwise in the contract, Ruijie Networks does not provide any explicit or implicit statements or warranties regarding the content of this document.

The names, links, descriptions, screenshots, and any other information regarding third-party software mentioned in this document are provided for your reference only. Ruijie Networks does not explicitly or implicitly endorse or recommend the use of any third-party software and does not make any assurances or guarantees concerning the applicability, security, or legality of such software. You should choose and use third-party software based on your business requirements and obtain proper authorization. Ruijie Networks assumes no liability for any risks or damages arising from your use of third-party software.

The content of this document is subject to constant change due to product version upgrades or other reasons. Thus, Ruijie Networks reserves the right to modify the content of the document without prior notice or prompt.

This manual serves solely as a user guide. While Ruijie Networks endeavors to ensure the accuracy and reliability of the content when compiling this manual, it does not guarantee that the content of the manual is free of errors or omissions. All information contained in this manual does not constitute any explicit or implicit warranties.

Preface

Intended Audience

This document is intended for:

- Network engineers
- Technical support and servicing engineers
- Network administrators

Technical Support

- Ruijie Reye website: <https://reyee.ruijie.com>
- Online support center: <https://reyee.ruijie.com/en-global/support>
- Case portal: <https://www.ruijie.com/support/caseportal>
- Community: <https://community.ruijie.com>
- Email support: service_rj@ruijie.com
- Live chat: <https://reyee.ruijie.com/en-global/rita>

Conventions

1. Signs

The signs used in this document are described as follows:

Danger

An alert that calls attention to safety instruction that if not understood or followed can result in personal injury.

Warning

An alert that calls attention to important rules and information that if not understood or followed can result in data loss or equipment damage.

Caution

An alert that calls attention to essential information that if not understood or followed can result in function failure or performance degradation.

Note

An alert that contains additional or supplementary information that if not understood or followed will not lead to serious consequences.

Specification

An alert that contains a description of product or version support.

2. Notes

This manual provides installation steps, troubleshooting, technical specifications, and usage guidelines for cables and connectors. It is intended for users who want to understand the above and have extensive experience in network deployment and management, and assume that users are familiar with related terms and concepts.

Contents

| | |
|---|---|
| Preface | I |
| 1 Overview | 1 |
| 1.1 Introduction to the RG-NSEC-SIC-LTE-S | 1 |
| 1.2 Appearance..... | 1 |
| 1.3 Technical Specifications | 3 |
| 2 Preparing for Installation | 4 |
| 1.1 Safety Guidelines..... | 4 |
| 1.1.1 General Safety Guidelines..... | 4 |
| 1.1.2 Chassis-Lifting Guidelines | 4 |
| 1.1.3 Electricity Safety | 4 |
| 1.1.4 Preventing ESD Damage..... | 4 |
| 1.2 Site Requirements | 5 |
| 1.2.1 Airflow..... | 5 |
| 1.2.2 Space Requirements | 5 |
| 1.2.3 Temperature and Humidity..... | 5 |
| 1.2.4 Cleanliness..... | 5 |
| 1.2.5 System Grounding | 6 |
| 1.2.6 Preventing Electromagnetic Interference | 7 |
| 1.2.7 Surge Protection | 7 |
| 1.2.8 Installation Site..... | 7 |
| 1.3 Tools | 7 |
| 1.4 Unpacking and Checking..... | 8 |

- 3 Installation 9
 - 3.1 Before You Begin..... 9
 - 1.5 Installing a 4G Module 9
 - 1.1 Verifying Installation..... 10
- 4 Commissioning..... 11
 - 1.2 Setting Up the Configuration Environment 11
 - 1.3 Powering on the Device 11
 - 1.3.1 Checklist Before Power-on 11
 - 1.3.2 Powering on the Device 11
 - 1.3.3 Checklist After Power-on 11
 - 1.4 Configuring the Device 11

1 Overview

1.1 Introduction to the RG-NSEC-SIC-LTE-S

The RG-NSEC-SIC-LTE-S is a data module that supports WCDMA, TDD-LTE, and LTE FDD (referred to as 4G module). It can be inserted into the SIC slot of the RG-CF30 series firewalls to enable the firewalls to realize wireless data transmission of 3G/4G public networks.

1.2 Appearance

Figure 1-1 Appearance of the RG-NSEC-SIC-LTE-S



Figure 1-2 RG-NSEC-SIC-LTE-S Faceplate



Table 1-1 RG-NSEC-SIC-LTE-S Faceplate Description

| No. | Parts | Description |
|-----|---|---|
| 1 | Tightening the anchor | Used to secure the 4G service module to the firewall. |
| 2 | 4G antenna (interface) | Used to receive and transmit 3G/4G signals and optimize the network quality |
| 3 | SIM card slot 1 (left), SIM card slot 2 (right) | Accommodates a SIM card. |

1.3 Technical Specifications

Table 1-2 Technical Specifications

| | |
|--|--|
| Model | RG-NSEC-SIC-LTE-S |
| Applicable Gateway Model | RG-CF30XS, RG-CF30XS-H |
| 4G Interface | One 4G interface |
| Connector Type | Two SMA-J interfaces (ANT 1 and ANT 2) for connecting dual antennas |
| Antenna | Two 4G antennas in the standard configuration |
| Supported Rate | FDD-LTE: B1/ 2/ 3/ 4/ 5/ 7/ 8/ 12/ 13 /14/ 17/ 18/ 19/ 20/ 25/ 26/ 28/ 29/ 30 / 32/ 66/ 71 TDD-LTE: B34/ 38/ 39/ 40/ 41/ 42/ 43/ 46/ 48 WCDMA:B1/ 2/ 3/ 4/ 5/ 6/ 8/ 19 |
| SIM Card | Dual SIM single standby Two Micro SIM cards |
| Configuring Module Hot Swapping | Not supported |
| Dimensions (W X D X H) | 103.37mm x 123mm x 28mm |
| Maximum Power Consumption | 5W |
| Operating Temperature | 0°C to 45°C (32°F to 113°F) at an altitude of 0 m to 1,800 m (32 ft. to 11,800 ft.) At a height between 1,800 m (5905.51 ft.) and 5,000 m (16404.20 ft.), every time the altitude increases by 220 m (721.78 ft.), the maximum temperature decreases by 1° C (1.8°F). |
| Operating Humidity | 10% to 90% RH (non-condensing) |

2 Preparing for Installation

1.1 Safety Guidelines

Note

- To avoid personal injury or equipment damage, review the safety guidelines in this chapter before you begin the installation.
 - The following safety precautions may not include all the potentially hazardous situations.
-

1.1.1 General Safety Guidelines

- Do not place the device in a wet position, and keep the device away from liquid. Keep the chassis clean and dust-free.
- Keep the equipment far away from heat sources.
- Ensure that the rack and power distribution system are properly grounded.
- Keep the equipment away from walking areas.
- Do not wear loose clothing or ornament that may get caught in the chassis.
- Keep tools and components away from areas where you or others could trip over them.

1.1.2 Chassis-Lifting Guidelines

- The chassis is not intended to be moved frequently.
- Turn off all power supplies and disconnect all power cords before lifting or moving the equipment.
- When moving a MU, at least two operators are required. Do not move the MU alone, and keep the balance to avoid hurting your legs and feet or twisting your waist.

1.1.3 Electricity Safety

Warning

- Improper electric operations may cause a fire, electric shock, and other accidents, which may lead to severe and fatal personal injury and equipment damage.
 - Direct or indirect touch through a wet object on high-voltage and mains supply can bring a fatal danger.
-

- Always observe the local regulations and standards. Only trained and qualified personnel should be allowed to operate the equipment.
- Carefully check your work area for possible hazards, such as ungrounded power extension cables, missing safety grounds, and moist floors.
- Locate the emergency power-off switch in the room. In the case of an electrical accident, you will be able to quickly turn off the power.
- Be sure to make a careful check before shutting down the power supply.
- You are advised to use an uninterruptible power source (UPS) to avoid power failures and disturbance.

1.1.4 Preventing ESD Damage

- Ensure that the chassis is connected to earth ground.
- Keep the site as dust free as possible.
- Maintain appropriate humidity conditions.
- Wear an anti-ESD wrist strap and make sure that it is properly grounded.
- Do not touch the printed circuit boards or component boards with bare hands.
- Store the module not in use in a static-shielding container or place it on an anti-ESD workbench.
- Avoid contact between the clothing and other items with the printed circuit board. The ESD wrist strap can only prevent damage to the printed circuit board caused by static electricity on the body. Static electricity on clothing cannot be prevented.

1.2 Site Requirements

The equipment must be installed and used indoors for normal operation and prolonged service life of the equipment.

The installation site must meet the following requirements.

1.2.1 Airflow

Maintain sufficient space around air vents to ensure adequate airflow through the chassis. Manage the Ethernet cables and power cords using cable ties or cable management brackets to avoid blocking air intakes.

1.2.2 Space Requirements

To have sufficient room for chassis handling and module swapping, you are advised to maintain an indoor pathway of at least 800 mm (31.50 in.) wide.

Do not install the device against the wall. Instead, maintain a minimum clearance of 400 mm (15.75 in.) around the device for ventilation and maintenance.

1.2.3 Temperature and Humidity

To ensure the normal operation and prolonged service life of the equipment, maintain appropriate temperature and humidity conditions in the equipment room.

Prolonged exposure to inappropriate temperature and humidity conditions can cause damage to the equipment.

- In an environment with a high relative humidity, insulating materials are prone to poor insulation or even electricity leakage.
- In an environment with a low relative humidity, insulating gaskets may shrink, resulting in screw loosening.
- In a dry environment, static electricity is more likely to occur, posing a risk to the internal circuits of equipment.
- A high temperature can accelerate the aging process of insulation materials, greatly reducing the availability of the equipment and severely affecting its service life.

Table 2-1 Temperature and Humidity

| Temperature | | Relative Humidity | |
|--------------------------------|-------------------------------|--------------------------------------|-----------------------------------|
| Long-term operating conditions | Short-term working conditions | Long-term operating conditions | Short-term working conditions |
| 15°C~30°C | 0°C~45°C | 40% RH to 65% RH (non-condensing) | 10% to 90% RH (non-condensing) |

i Note

- The operating temperature and humidity are measured at 1.5 m (4.92 ft.) above the floor and 0.4 m (1.31 ft.) before the rack when there is no protective plate in front or on the rear of the rack.
- Short-term operating: The continuous operating period is no more than 48 hours or the total operating period per year is no more than 15 days.

1.2.4 Cleanliness

Dust poses a significant hazard to the equipment. The indoor dust takes on a positive or negative static electric charge when falling on the switch, causing poor contact of the metallic joint. Such electrostatic adhesion may

occur more easily when the relative humidity is low, not only affecting the service life of the switch, but also causing communication faults. The following table lists the requirements for dust concentration and particle size in the equipment room.

Table 2-2 Dust and Particles Requirement

| Minimum Dust and Particles Diameter | Content (Particles/m ³) |
|-------------------------------------|-------------------------------------|
| ≥ 0.5 μm | ≤1.4x10 ⁷ |
| ≥ 1 μm | ≤7x10 ⁵ |
| ≥ 3 μm | ≤2.4x10 ⁵ |
| ≥ 5 μm | ≤1.3x10 ⁵ |

Apart from dust, there are also requirements on the salt, acid, and sulfide in the air of the equipment room. These harmful substances will accelerate metal corrosion and component aging. Therefore, the equipment room should be properly protected against the intrusion of harmful gases, such as sulfur dioxide, hydrogen sulfide, nitrogen dioxide, and chlorine gas. The following table lists limit values for harmful gases.

Table 2-3 Gas Requirement

| Gas | Average (Mg/m ³) | Maximum (Mg/m ³) |
|-------------------------------------|------------------------------|------------------------------|
| Sulfur dioxide (SO ₂) | 0.2 | 1.5 |
| Hydrogen sulfide (H ₂ S) | 0.006 | 0.03 |
| Nitrogen dioxide (NO ₂) | 0.04 | 0.15 |
| Ammonia gas (NH ₃) | 0.05 | 0.15 |
| Chlorine gas (Cl ₂) | 0.01 | 0.3 |

 Note

Average refers to the average value of harmful gases measured in a week. Maximum refers to the upper limit of harmful gases measured in a week for up to 30 minutes every day.

1.2.5 System Grounding

A reliable grounding system is the basis for stable and reliable operation, which is indispensable for preventing lightning strikes and interference. Carefully check the grounding conditions at the installation site according to the grounding requirements, and complete grounding properly based on the site situation.

- Safety Grounding

Ensure that the cabinet and power distribution device are securely grounded when the device uses the AC power supply. Otherwise, electric shock may occur when the insulation resistance between the power supply inside the switch and the chassis becomes small.

 **Caution**

The building should provide a protective ground connection to ensure that the equipment is connected to a protective ground.

- **Lightning Grounding**

The lightning protection system is an independent system composed of a lightning rod, a down conductor, and a connector connected to the grounding system. The grounding system is typically used for power reference grounding and safety grounding of the rack. Lightning grounding is required only for facilities, and is not required for the equipment.

- **EMC Grounding**

Electromagnetic compatibility (EMC) grounding includes shielded grounding, filter grounding, noise and interference suppression, and level reference.

which contribute to the overall grounding requirements. The grounding resistance should be smaller than 1 ohm. Before operating the device, make sure that the cabinet or workbench is properly grounded.

1.2.6 Preventing Electromagnetic Interference

- Take interference prevention measures for the power supply system.
- Keep the equipment far away from the grounding system or lightning protection grounding system of the power facility.
- Keep the equipment far away from high-frequency current equipment such as a high-power radio transmitting stations and radar launchers.
- Take electromagnetic shielding measures when necessary.

1.2.7 Surge Protection

- Although the equipment can guard against lightning strikes, strong lightning strikes may still damage the equipment. Take the following surge protection measures:
- Ensure that the grounding cable of the rack is in good close contact with the ground.
- You are advised to install a power arrester in front of the power input end to enhance surge protection for the power supply.

1.2.8 Installation Site

Regardless of whether the equipment is installed in a rack or on a workbench, ensure that the following conditions are met:

- Maintain a proper clearance around the air inlets and outlets for heat dissipation.
- Some models are equipped with fans to draw air from side to rear. Maintain a minimum clearance of 150 mm (5.91 in.) around the air outlets for heat dissipation. You are advised to install the equipment in a standard 19-inch rack, or place it on a clean workbench. In hot areas, air-conditioning is recommended.
- The installation site has a good cooling and ventilation system.
- The installation site is sturdy enough to support the weight of the chassis and its components.
- The installation site is properly grounded.

1.3 Tools

The following table lists the instruments and meters required during the 4G module installation. [Table 2-4](#).

Table 2-4 Tools

| Meters | BOM |
|-----------------|----------------------|
| Common tools | Phillips screwdriver |
| Dedicated tools | ESD-preventive glove |

**Note**

The product is not shipped with a toolkit. You need to prepare the tools and meters listed in the tool kit.

1.4 Unpacking and Checking

Before installing the device, open the accessory package and check whether all accessories are included.

3 Installation

 Caution

- Before installing the equipment, ensure that guidelines and requirements in Chapter 2 have been met.
 - The installation diagram provided here is for reference only. The actual installation process may vary depending on the specific device model.
-

3.1 Before You Begin

Subject to [2 Preparing for Installation](#) Complete preparations before installation and check the following items:

- The installation site provides sufficient space for heat dissipation.
- The installation site meets the temperature and humidity requirements.
- The power supply is available at the installation site, and its current meets the requirements.
- The Ethernet cables have been deployed at the installation site.
- The power supply meets the requirements.
- Find out the position of the emergency power switch before installation, so that the power switch can be cut off in case of accidents.

1.5 Installing a 4G Module

Application Scenario

The RG-NSEC-SIC-LTE-S can be installed on the RG-CF30XS and RG-CF30XS-H firewalls. If you have purchased this module, install it according to this section to avoid any damage.

Precautions

4G modules do not support hot swapping. Therefore, install or remove a 4G module when the device is powered off.

Procedure

- (1) On the rear panel of the firewall, unscrew the two fastening screws on the faceplate of the 4G module counterclockwise, remove the faceplate, and keep it properly.
- (2) Align two 4G antennas with ANT interfaces, tighten them clockwise, and slowly push the 4G module horizontally into the slot until it is completely inserted into the slot.

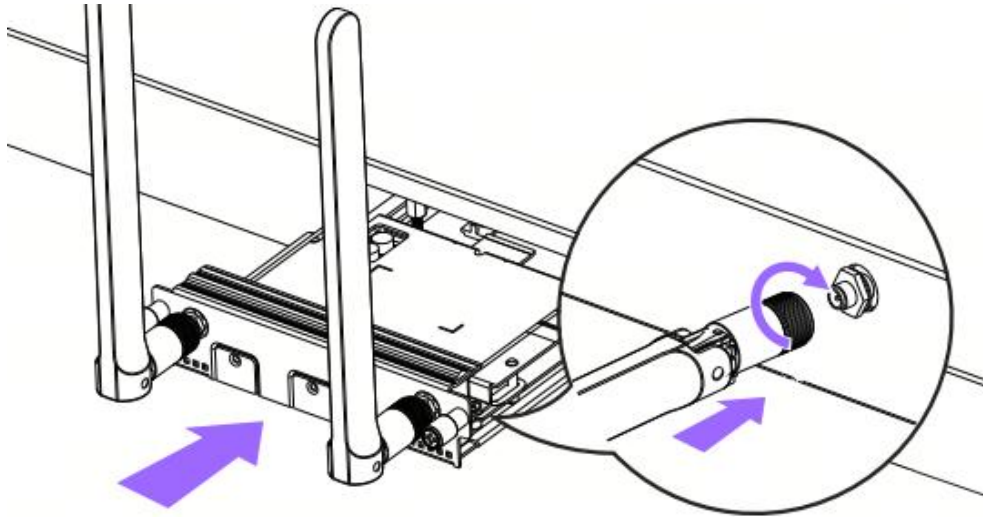

(3) Tighten the fastening screws on the expansion card clockwise.

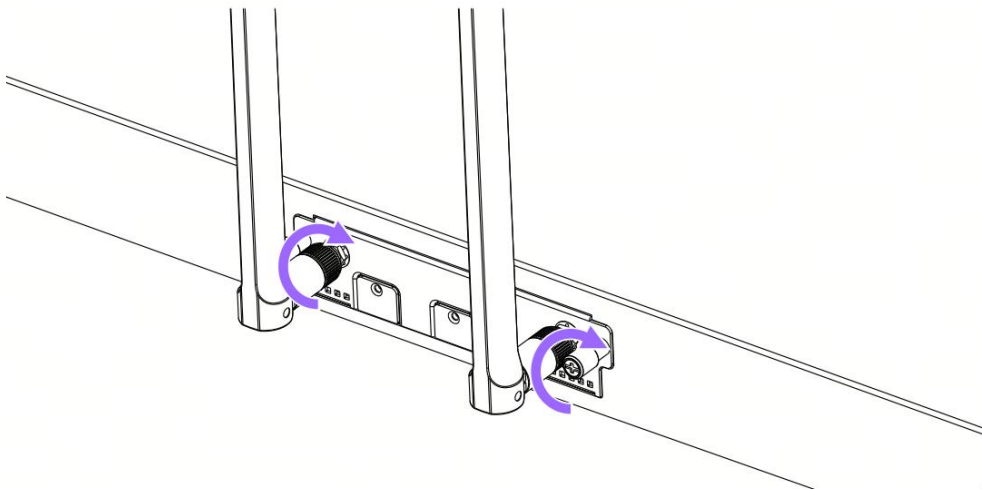

(4) Rotate the fastening screws on the faceplate of the SIM card slot counterclockwise, remove the faceplate, insert the SIM card in the direction indicated on the faceplate, and then install the faceplate back in place.

1.1 Verifying Installation

After installing the 4G service module, install the firewall. For details about the firewall, see the Hardware Installation and Reference Guide.

Before powering on the firewall, check the following items to ensure normal operation of the firewall.

- If the device is installed in a cabinet, check whether the device is securely installed in the cabinet and whether sufficient space is reserved around the device for heat dissipation. If the device is installed on a workbench, check whether sufficient space is reserved around the device and whether the workbench is stable.
- The specifications of the external power supply system meet requirements of the device.
- The protective earthing conductors of the device are properly connected.
- The power cord is correctly and reliably connected, and is in good contact. The power cord is long enough to avoid being tightened, which reduces its service life.
- The device is correctly connected to other devices such as the configuration terminal.

4 Commissioning

1.2 Setting Up the Configuration Environment

Firewalls provide the following default management IP addresses: [Table 4-1](#) shows the default settings.

Table 4-1 Factory Settings

| | |
|-----------------------------------|-----------------------------------|
| Login Address | 10.20.30.42/24 |
| Logging In to an Interface | MGMT port |
| Account and Password | Account: admin Password: admin |

Procedure

- (1) Connect the network port of the management PC to the MGMT port of the device through an Ethernet cable.
- (1) Set the IP address of the PC to be in the same network segment as the MGMT interface and a non-conflicting IP address. Example: 10.20.30.1/24.

1.3 Powering on the Device

1.3.1 Checklist Before Power-on

- Connect the device to the ground properly.
- The power cord is correctly connected.
- The external supply voltage is in line with the device requirements.
- Verify that the Ethernet cable is correctly connected.

1.3.2 Powering on the Device

Turn on the power switch of the power supply equipment.,

1.3.3 Checklist After Power-on

Determine whether the AP is working properly based on indicators on the AP.

Table 4-2 LED Status After Power-on

| LED | Normal |
|-------------------------|-------------|
| SYS status LED | Solid green |
| 4G status LTE LED (LTE) | Solid green |

1.4 Configuring the Device

Open a browser on the management PC, enter <https://10.20.30.42>, and press Enter to log in to the web management page of the device. Choose Network > Interface > Cellular Interface to configure 4G services. For details about device configuration, see the user manual of the corresponding version.