

# UltraStar® US 5, US 6, US 7 | Strobe Beacon

## Features

- Powder coated aluminum die-cast base
- Shock-mounted strobe tube
- Industry standard mounting: permanent/1" pipe, magnetic and J-bolt
- Five-year product warranty

### US 5

- 13 Joules, double flash and 14 Joules, quad flash

### US 6

- 17/12 Joules, double flash
- Built-in photocell provides automatic adjustment to ambient light for day or night operation (may be converted to a manual [switchable] adjustment)
- Potted, fully-encapsulated power supply

### US 7

- Power supply produces 21 Joules
- Built-in photocell provides automatic adjustment to ambient light for day or night operation (may be converted to a manual [switchable] adjustment)
- Potted, fully-encapsulated power supply

## Approvals

- SAE J1318 Class 1 (tall dome models)
- SAE J1318 Class 2 (short dome models)

## Applications

- Construction
- Municipal
- Utility



CLASS 1 CLASS 2

Model	Description
<b>US5, 13J, 12-24 VDC, 18.4 W, double flash, tall dome</b>	
250121-02	Permanent/pipe mount, Amber; -03(Blue); -04(Red); -05(Clear), Class 1
250141-02	Magnetic mount, Amber; -03(Blue); -04(Red); -05(Clear), Class 1
<b>US5, 13J, 12-24 VDC, 18.4 W, double flash, short dome</b>	
251121-02	Permanent/pipe mount, Amber; -03(Blue); -04(Red); -05(Clear), Class 2
251141-02	Magnetic mount, Amber; -04(Red), Class 2
<b>US6, 17/12J, 12-24 VDC, 21.3/15 W, double flash</b>	
252600-02	Permanent/1" pipe mount, Amber; -03(Blue); -04(Red); -05(Clear), Class 1
252601-02	Magnetic mount, Amber; -04(Red), Class 1
<b>US7, 21/13J, 12-24 VDC, 26.3/16.3 W, quad flash, tall dome</b>	
250721-02	Permanent/pipe mount, Amber; -03(Blue); -05(Clear), Class 1
250741-02	Magnetic mount, Amber; -05(Clear), Class 1
<b>Accessories and Kits</b>	
SW2	Switch control
448310	Kit, vibration mount
448320	MZDGP pipe mount adapter for 448330 branch guard
448330	MZDGK branch guard
Z8444373A-01	Dust cover, tall dome, Clear
Z8444375A-01	Dust cover, short dome, Clear
<b>Common Replacement Parts</b>	
251500	Flash tube, US5
251501	Flash tube, US7
250520	Double flash power supply, US5
250530	Quad flash power supply, US7
Z8444372A	Dome, tall; -01(Clear); -02(Red); -03(Amber); -04(Blue); -05(Green)
Z8444374A	Dome, short; -01(Clear); -02(Red); -03(Amber); -04(Blue); -05(Green)
Z8575272A	Flash tube assembly, US6

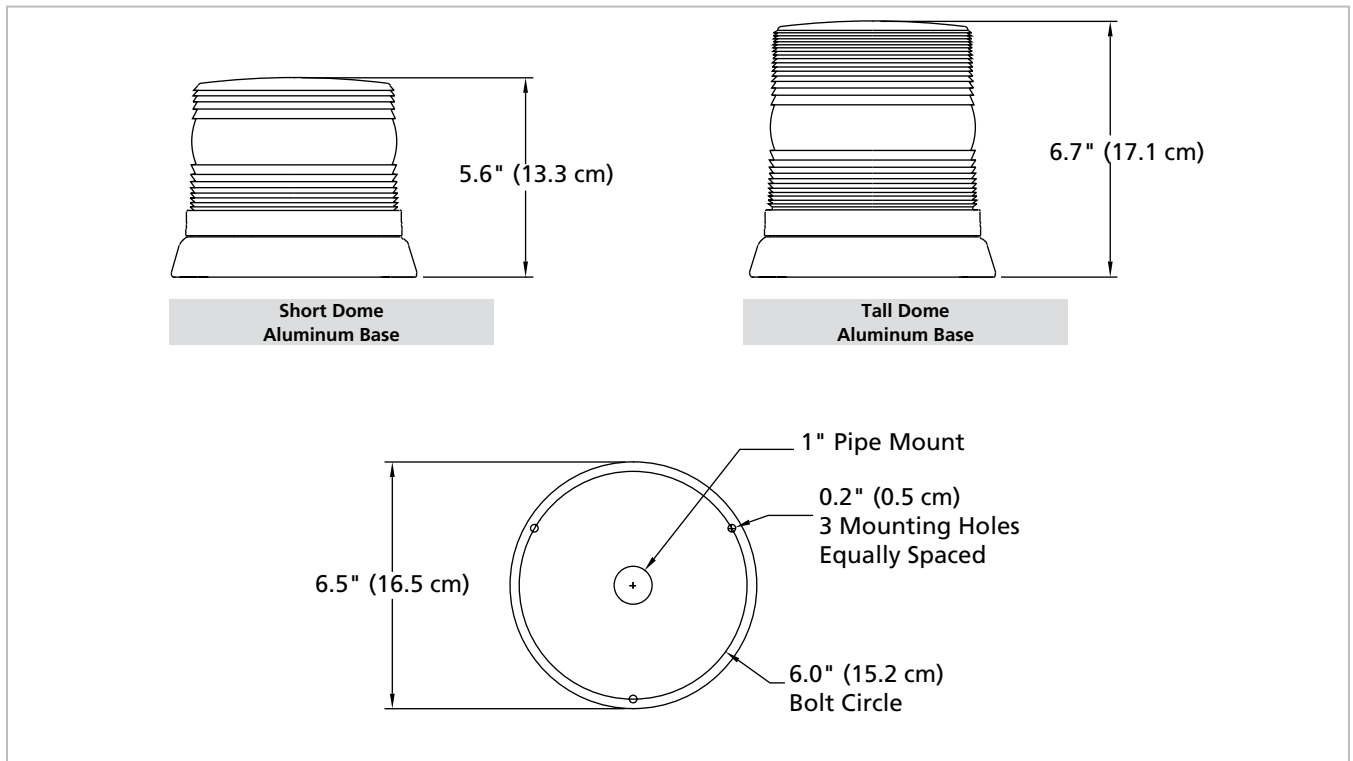

Model	Operating Voltage	Amp Draw	Joules	Watts	FPM	Approvals	Base Material	Dome Colors	Dimensions (D x H)	Ship Weight (lbs)	Warranty (years)
<b>UltraStar US 5</b>	12/24	1.8 A @ 12 V to 0.9 A @ 24 V	13/14	18.4/19	85/80	Class 1 & 2	Aluminum	Amber, Blue, Clear and Red	6.5" x 6.74" (Tall) 6.5" x 5.25" (Short)	4.0	5
<b>UltraStar US 6</b>	12/24	2.0 A @ 12.8 V to 1.2 A @ 25.6 V (high); 1.6 A @ 12.8 V to 0.8 A @ 25.6 V (low)	17/12	17/12	75	Class 1	Aluminum	Amber, Blue, Clear and Red	6.5" x 6.7" (Perm.) 6.5" x 6.9" (Mag.)	4.25 (Perm.) 4.95 (Mag.)	5
<b>UltraStar US 7</b>	12/24	2.5 A @ 12 V to 1.2 A to 24 V	21/13 Hi-Lo	21.3/15	75	Class 1	Aluminum	Amber, Blue, Clear and Red	6.5" x 6.7" (Tall)	4.0	5



448330



448320