

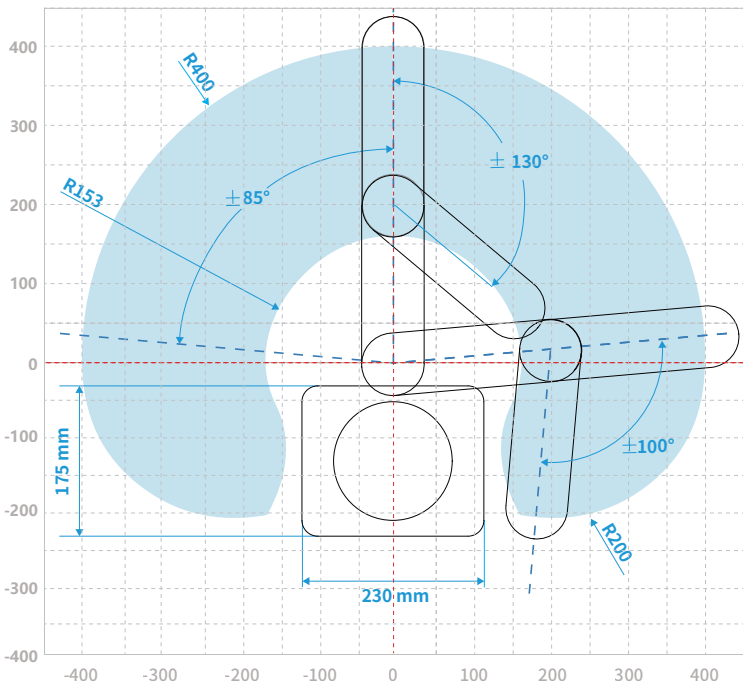

## DOBOT M1 Pro

中国·深圳市越疆科技有限公司  
Shenzhen Yuejiang Technology Co.,Ltd. | China  
cn.dobot.cc

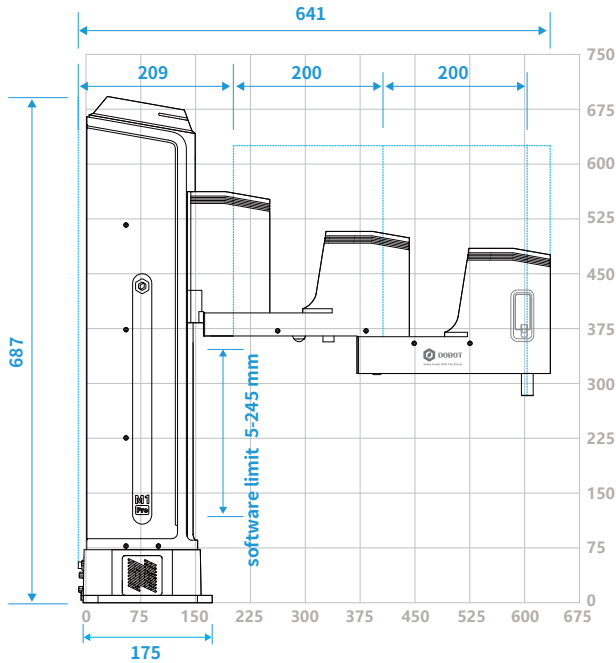

**Product Name** DOBOT M1 Pro  
**Product Model** DT-M1-P4R15-01I

**Controlled Axes** 4  
**Rated Load** 1.5kg  
**Max. Reach** 400 mm  
**Repeatability** ±0.02 mm

Motion Parameters	Joint	Motion Range	Max. Speed
	J1	±85°	180°/s
	J2	±130°	180°/s
	J3	5mm ~ 245mm	1000mm/s
	J4	±360°	1000°/s

**Power Input** 100~240 VAC, 50/60 Hz  
**Rated Voltage** DC 48 V  
**Rated Power** 192 W  
**Communication** TCP/IP, Modbus TCP  
**Installation** Desktop  
**Weight** 15.7 kg  
**Base Dimension** 230 mm × 175 mm  
**Work Environment** 0 °C~40 °C  
**Software** DobotStudio 2020, SCStudio

### Interface

**Base:** Digital Input 16  
Digital Output 16  
Ethernet 2  
USB 2.0 2  
Encoder Input 1  
Emergency Stop 1

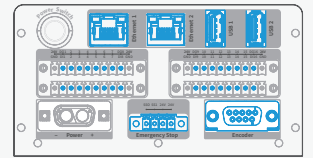

**End:** Digital Input 4  
Digital Output 4

### Mounting Drawing

