

## FULL HEIGHT MAXIMUM SECURITY TURNSTILE

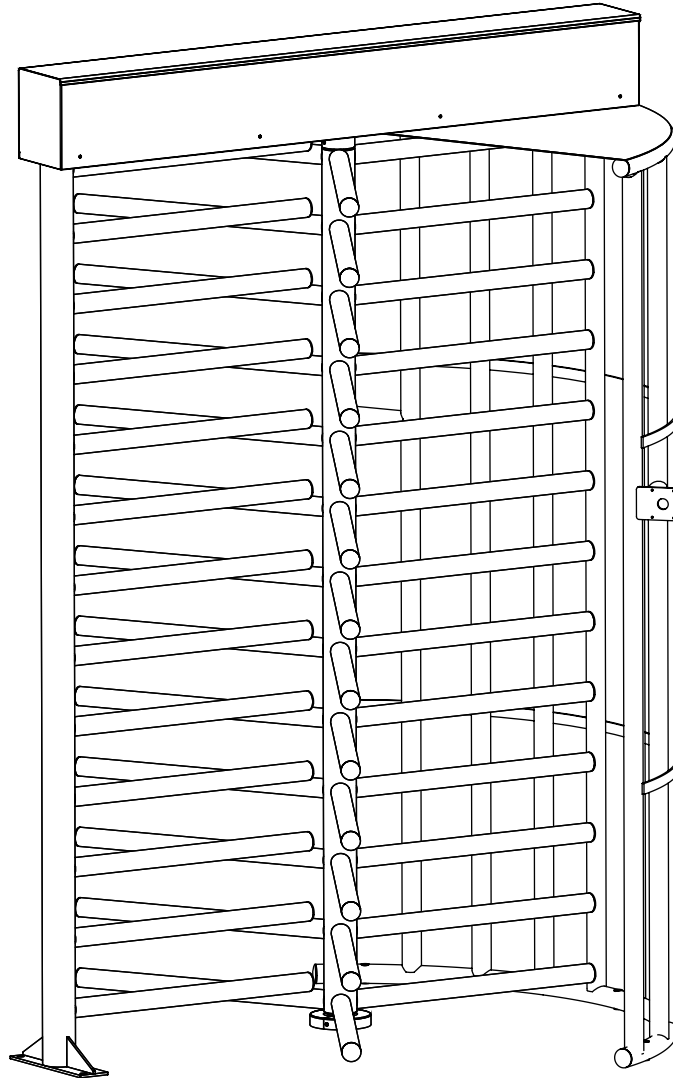

### Installation and Operation Instructions

---

**Alvarado Manufacturing Company, Inc.**

12660 Colony Street, Chino, CA 91710

Phone: (909) 591-8431

Fax: (909) 628-1403

support@alvaradomfg.com

www.alvaradomfg.com



**Contents**

Contents ..... 2

Safety Precautions ..... 3

Safety Icons ..... 3

Compliance and Standards ..... 4

Installation Tools ..... 4

Parts List ..... 5

Before You Begin ..... 6

Common Terms ..... 6

Installation Instructions ..... 7

    Installation Locations ..... 7

    Bottom Bearing Plate Installation ..... 8

    Yoke Installation ..... 9

    OV Installation ..... 10

Roto Installation ..... 10

Top Channel Installation ..... 11

Guard Plate Installation ..... 13

Bearing Cover Installation ..... 14

    Top Bearing Cover Installation ..... 14

    Bottom Bearing Cover Installation ..... 14

Final Mechanical Installation Steps ..... 15

Key Override Operation ..... 15

Conduit Instructions ..... 16

Electrical Wiring Instructions ..... 17

    Turnstile Control Board Layout ..... 18

    Terminal Descriptions ..... 19

    SW4 DIP Switch Descriptions ..... 21

User Activation and Passage Instructions ..... 22

Post-Installation Checklist ..... 23

Troubleshooting ..... 24

Cleaning and Maintenance ..... 29

Lubrication ..... 31

Appendix A - CPST Installation ..... 33

    Yoke Installation ..... 34

Appendix B - CLST Installation ..... 36

Appendix C - FMST Installation ..... 37

Appendix D - MST47 Installation ..... 38

Appendix E - Fail-lock / Fail-safe Spring and Solenoid Configurations ..... 39

    Clockwise ..... 39

    Fail-safe ..... 39

    Fail-lock ..... 39

    Counterclockwise ..... 40

    Fail-safe ..... 40

    Fail-lock ..... 40

Appendix E - Fail-lock / Fail-safe Spring and Solenoid Configurations (Cont) ..... 41

    Clockwise ..... 41

    Fail-safe ..... 41

    Fail-lock ..... 41

    Clockwise ..... 42

    Fail-safe ..... 42

    Fail-lock ..... 42

Appendix F - Key Override Adjustable Cam Installation ..... 43

    Clockwise ..... 43

    Counterclockwise ..... 44

Revision History ..... 45



## Safety Precautions

The Full Height Security Turnstile may present a risk to persons and property if it is not installed and/or operated correctly. This manual must be read in its entirety and all safety and operations information must be followed. Note the following precautions:

- Use only skilled individuals to install and service the turnstile.
  - DO NOT operate the turnstile if it has been damaged in any manner. If damaged, have the unit repaired or adjusted by a skilled service person before use.
  - DO NOT modify or alter the turnstile.
  - Have skilled individuals maintain the turnstile according to a proper maintenance schedule.
  - In access control applications, train all personnel that will be using the turnstile in the proper method of operation. In addition, properly train new users as they are added to the system.
  - DO NOT use non-Alvarado parts to repair a damaged turnstile.
  - Closely follow the handling instructions for moving or lifting the turnstile during installation.
  - Power off the turnstile before connecting or disconnecting any communication or power wiring to the turnstile.
  - The turnstile is not a toy. DO NOT allow children to play on or near the turnstile. DO NOT allow horseplay near the turnstile.
- 
- Utilisez uniquement des personnes qualifiées pour installer et entretenir le tourniquet.
  - NE PAS faire fonctionner le tourniquet s'il a été endommagé de quelque façon. S'il est endommagé, faire réparer ou ajuster l'unité avant l'utilisation par un(e) préposé(e) à l'entretien qualifié(e).
  - NE PAS modifier ou altérer le tourniquet.
  - Le tourniquet doit être maintenu selon un calendrier d'entretien adéquat par des personnes qualifiées.
  - Dans les applications de contrôle d'accès, former tout le personnel qui utilisera le tourniquet selon la bonne méthode de fonctionnement. De plus, bien former les nouveaux utilisateurs à leur intégration au système.
  - NE PAS utiliser des pièces ne provenant pas du Alvarado pour réparer un tourniquet endommagé.
  - Suivez strictement les instructions de manutention pour déplacer ou soulever le tourniquet lors de l'installation.
  - Éteignez le tourniquet avant de brancher ou de débrancher le câblage de communication ou le câblage d'électricité.
  - Le tourniquet n'est pas un jouet. Ne pas laisser les enfants jouer sur ou près du tourniquet. Ne pas se chamailler près du tourniquet.

**SAVE THESE INSTRUCTIONS**

## Safety Icons

The following symbols are used throughout the manual to highlight important information and potential risks when installing, servicing or using the turnstiles covered in this manual.



**WARNING**

This symbol is used in this manual to warn installers and operators of potential harm. Please read these instructions very carefully.



**CAUTION**

This symbol is used in this manual to designate potential conditions that may pose a risk to pedestrians, personnel, property and equipment. Please read these instructions very carefully.

**NOTE**

This symbol is used in this manual to designate useful information for the installer and operator. Please read these instructions.



For questions, please contact Alvarado at (909) 591-8431, Monday – Friday 7:00am to 4:30 PST. Please read this manual completely before installing or operating the product.

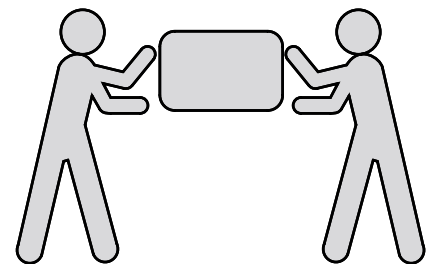

A minimum of two people is required to complete the installation of this product.



### Compliance and Standards

This page defines the product labels required for compliance with UL Electrical Testing Laboratory and International CE standards.

#### International CE standards:

a. Label (2) the Fuse Specification.



b. Label (3) the Warning, Risk of Electric Shock.



c. Label (4) the Caution, Risk of Danger.



#### UL 294, UL 325 Testing Laboratory Standards:

a. Label (2) the Fuse Caution.

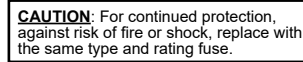

b. Label (3) the Warning, Risk of Electric Shock.

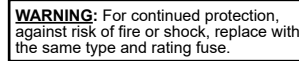

c. UL 294, Access Control Levels:

Destructive Attack - Level 1

Line Security - Level 1

Endurance - Level 4

Standby Power - Level 1

### UL Certification



This product is fully certified by a nationally recognized testing laboratory to UL 294, UL 325, and CSA C22.2 NO.247-14. Unauthorized modification to this product in any way is prohibited.

### Installation Tools

The following tools may be required during the installation, dependent on the specific product installed. These tools are not provided.

Tape Measure 	Drill 	Hammer Drill 	Chalk Line 	Wire Strippers 	Ladder 
Phillips Tip Screwdriver 	1/8" Allen Wrench 	Torque Wrench 	Socket Wrench 	9/16" Wrench 3/4" Wrench 	Level 
Flat Tip Screwdriver 	9/16" Socket 3/4" Socket 	5/8" Concrete Drill Bit 9/64" Drill Bit 	Pencil 	Grease (see "Lubrication") 	Clear RTV Silicone 







## Parts List

This product is shipped with all required installation hardware and components. Make sure that none of these parts are missing and/or damaged before beginning installation. If there are parts missing and/or damaged, please stop the installation and contact Alvarado.

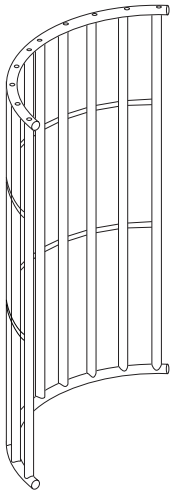
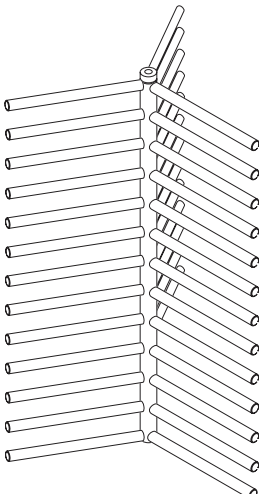
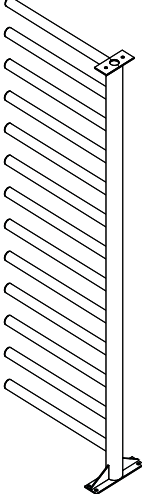
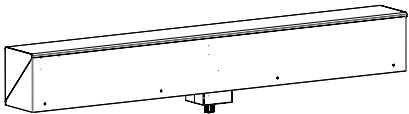
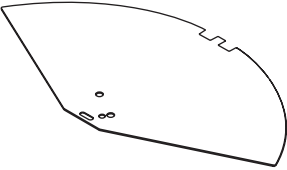
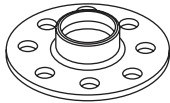
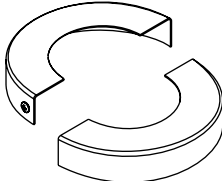
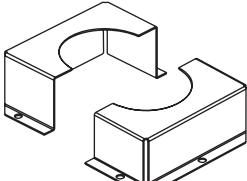

**NOTE**

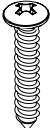
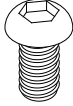
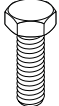
Alvarado full height turnstiles share common components across models. The parts list below is for the MST-3 and MST-6X models only. Reference appendix A-D to see alternate components used on other models.

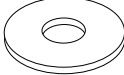
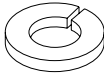
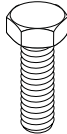
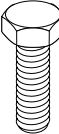
### MST Illustrated Parts List

 Yoke (Qty 1)	 Roto (Qty 1)	 OV (Qty 1)	 Top Channel (Qty 1)
 Yoke Guard Plate (Qty 1)	 Bottom Bearing Plate (Qty 1)	 Bottom Bearing Cover (Qty 1)	 Top Bearing Cover (Qty 1)
 Bottom Bearing (Qty 1)	 #10 x 3/4" Phillips Pan Head Screw (Qty 10)	 10-32 x 1/2" Allen Head Screw (Qty 6)	 1/2" x 1 1/2" Hex Head Bolt (Qty 2)
 1/2" Nut (Qty 5)	 1/2" Flat Washer (Qty 1)	 1/2" Lock Washer (Qty 5)	 1/2" x 1" Hex Head Bolt (Qty 1)
			 1/2" x 2 3/4" Hex Bolt Head (Qty 2)

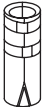
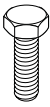
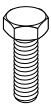
### Concrete Anchor Package

 3/8" x 2.00" Concrete Anchors (Qty 12)	 3/8" x 4 1/2" Anchor Bolt (Qty 3) - Yoke Only	 3/8" x 2 1/2" Anchor Bolt (Qty 12)	 3/8" Flat Washers (Qty 12)
--	---	---	--

**NOTE**

For stainless steel installations, discard the 2 1/2" zinc anchor bolts and 3/8" zinc flat washers packaged with the concrete anchors. Use the supplied 2 1/2" stainless steel anchor bolts and 3/8" stainless steel flat washers.

**Before You Begin**

This manual focuses on the installation of Alvarado full height turnstiles, using the MST and MSTX as the basis of instruction. Most steps are identical across models. Differences in components or installation process are called out, as applicable. These instructions are applicable for the installation of the following models:

MST-3  
MST-6X

CLST-3  
CLST-6X

CPST-6X

FMST-3  
FMST-6X

MST47-3  
MST47-6X

**Common Terms**

<b>Activation</b>	Activation (unlocking) of electric models is accomplished by providing a momentary dry contact of .5 seconds to 2 seconds or greater to the appropriate location on the turnstile control board. Activations are not buffered. After an activation is received, the turnstile will not accept another activation until the turnstile is rotated or the activation has timed out (see Time-Out below).
<b>Clockwise Rotation</b>	Turnstile arms rotate in a clockwise direction.
<b>Counterclockwise Rotation</b>	Turnstile arms rotate in a counterclockwise direction.
<b>Electric Lock Control</b>	Relevant to electric models only.  Electric units ("6X" models) provide electric lock control. The turnstile is unlocked by providing an activation (unlock signal), in the form of a momentary dry contact of .5 seconds to 2 seconds, to the appropriate location on the turnstile control board. Separate controls are provided for each direction of rotation.
<b>Fail-Lock</b>	Relevant to electric models only.  Upon loss of power, the rotating section (roto) cannot be rotated in the fail-lock direction(s).
<b>Fail-Safe</b>	Relevant to electric models only.  Upon loss of power, the roto freely rotates in the fail-safe direction(s).
<b>Key Override</b>	All full height turnstiles, whether manual or electric, come with key locks, located on the underside of the top channel, to allow key override control of the roto. Separate key overrides are provided for each rotation direction.  For manual units ("3" models), the key override control allows each rotation direction to be either locked (no passage) or unlocked (free passage).  For electric units ("6X" models), key override control allows each rotation direction to be locked, in which case the turnstile can be unlocked by an activation. Alternatively, key override control allows each direction of rotation to be unlocked, in which case the turnstile will freely rotate in the unlocked direction(s).
<b>Manual Control</b>	Manual control of the turnstile is available through use of the key override control function (see above).
<b>Self-Centering</b>	The turnstile arms automatically return to home position once rotation has been completed.
<b>Time-Out</b>	When the turnstile receives an activation (unlock signal), the user is allowed a set time to pass through the turnstile before it automatically re-locks. The factory default time-out setting is 20 seconds. The turnstile control board allows the user to decrease this time setting to 5, 10 or 15 seconds.



## Installation Instructions

### NOTE

Install the turnstile on a 6' x 6' (min.) level concrete slab. The slab must be a minimum of 4" thickness. The turnstile may only be installed on concrete. Do not install the turnstile on asphalt.

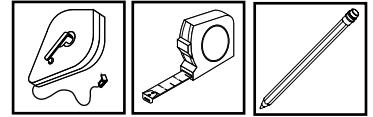

DIMENSIONS SHOWN ARE FOR MST-3 and MST-6X MODELS. SEE APPENDIX A-D FOR OTHER MODELS.

## Installation Locations

### NOTE

The turnstile is rated for both indoor and outdoor use.

1. Determine where the turnstile will be installed. Consider the overall footprint size of the unit when determining the installation location (Figure 1). Once the installation location has been determined, use a chalk line to mark the centerline of the turnstile.

### NOTES

Default entry rotation is counterclockwise. Confirm correct entry direction prior to installation.

Alvarado recommends that the minimum installation width required be 64".

2. Determine and mark the centerline location for the OV, Roto, and Yoke (Figure 2).

### NOTE

The overall height of the MST is 91.5". However, an additional 3" of clearance must be added for service and maintenance.

If desired, installers can stub up the power conduit at the intersection of the turnstile centerline and the OV centerline. Power may also be routed directly into the top channel (Figure 26).

Mark all center lines prior to installation.

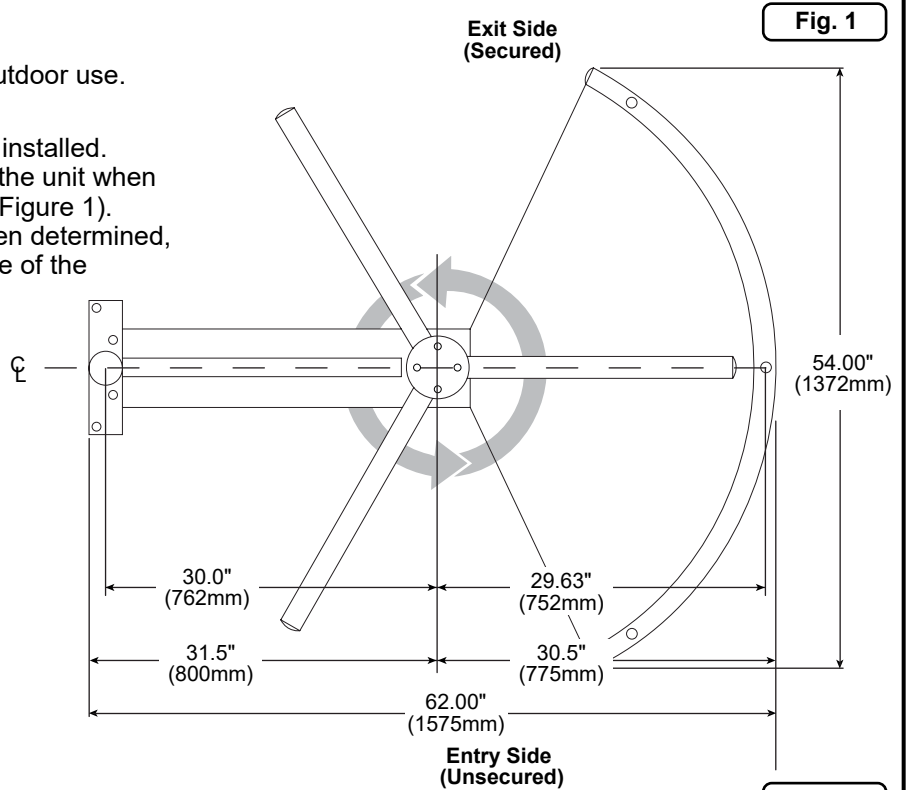
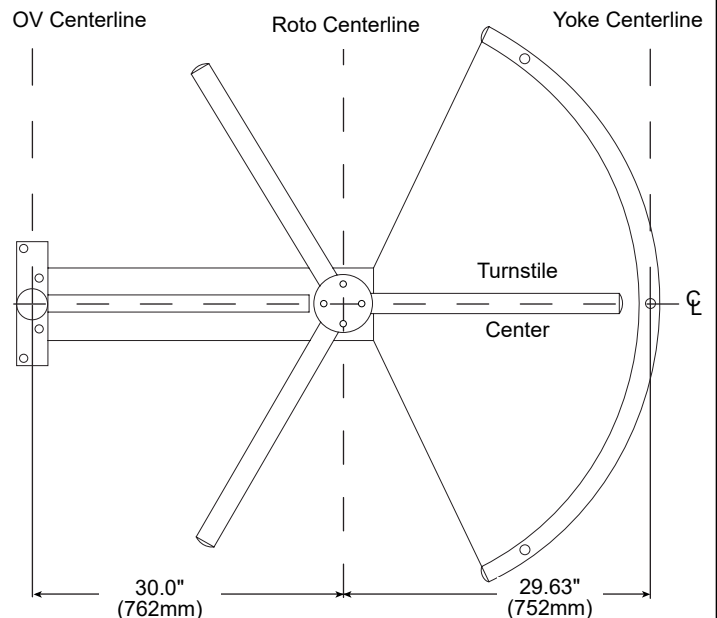

Fig. 1

Fig. 2





### Bottom Bearing Plate Installation

1. Place the bottom bearing plate over the turnstile and roto intersecting lines.
2. Mark the center location of all four anchor holes for the bottom bearing plate (Figure 3). Set aside the bottom bearing plate.
3. Using a  $\frac{5}{8}$ " concrete drill bit, drill four anchor holes, 3" in depth, at the center of each marked location (Figure 3).

**NOTE**

The anchor hole(s) must be clean before installing the anchor bolt(s). If the hole(s) are not clear of debris, the anchor bolt(s) may not tighten correctly.

4. Insert one anchor into each drilled hole (Figure 4). The threaded end of the anchor must be inserted into the hole first. Use a hammer to tap the anchor into place, if needed. Ensure that the anchors are flush with the concrete floor.
5. Place the bottom bearing plate back over the anchor holes and anchor it with four (4)  $\frac{3}{8}$ " x 2 $\frac{1}{2}$ " anchor bolts and flat washers (Figure 5).
6. Use a socket wrench and 9/16" socket to tighten the anchor bolts (Figure 6).
7. Confirm that the bottom bearing plate is level. Shim as needed.
8. Apply a thick bead of clear RTV silicone around the bottom bearing plate (Figure 6).

**NOTE**

Clear RTV silicone is a low volatile formula and has an application temperature range from -70°F up to 400°F.

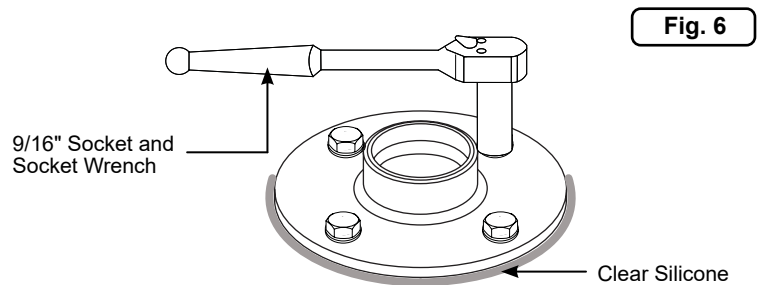
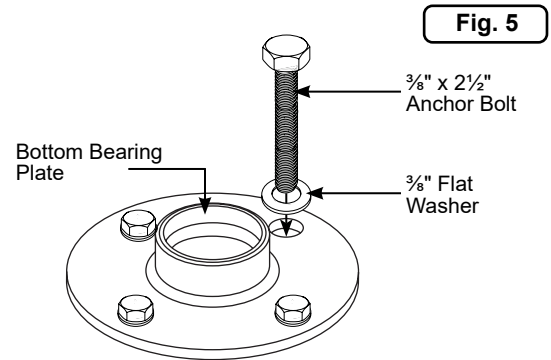
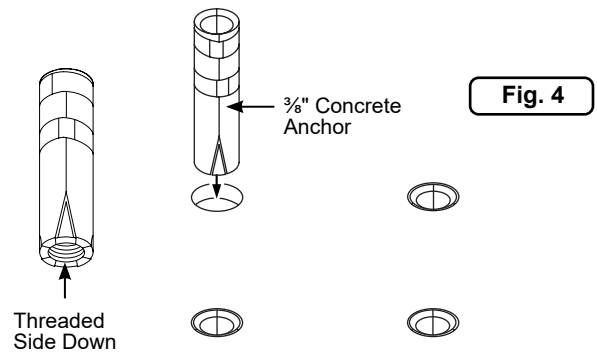
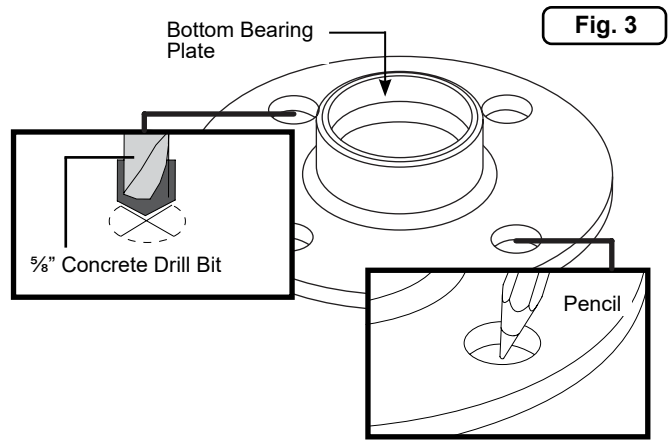



## Yoke Installation

### NOTES

Do not use a single yoke as a template when multiple turnstiles are installed, as yoke dimensions may vary slightly from yoke to yoke.

### NOTE

STEPS AND DIMENSIONS SHOWN ARE FOR MST MODELS. SEE APPENDIX A-D FOR OTHER MODELS.

1. Reconfirm the centerline location for the yoke (Figure 7).
2. Using a  $\frac{5}{8}$ " concrete drill bit, drill an anchor hole 3" in depth.

### NOTE

The anchor hole(s) must be clean before installing the anchor bolt(s). If the hole(s) are not clear of debris, the anchor bolt(s) may not tighten correctly.

3. Insert one anchor into the drilled hole (Figure 8A). The threaded end of the anchor must be inserted into the hole first. Use a hammer to tap the anchor into place, if needed. Ensure that the anchor is flush with the concrete floor.
4. Place the Yoke back over the anchor hole and anchor it with one  $\frac{3}{8}$ " x  $4\frac{1}{2}$ " anchor bolt and flat washer .

### NOTE

Prior to drilling the remaining anchor holes, use a tape measure and measure the distance from the bottom bearing plate center to the remaining mounting holes on the yoke (Figure 7). Adjust the yoke until these two distances are identical. Mark these two locations.

5. Rotate the yoke to the left. Using a  $\frac{5}{8}$ " concrete drill bit, drill two anchor holes 3" in depth at the center of each marked location.
6. Insert two anchors into the drilled holes (Figure 8A). The threaded end of the anchors must be inserted into the holes first. Use a hammer to tap the anchors into place, if needed. Ensure that the anchors are flush with the concrete floor.
7. Rotate the yoke back over the anchor holes and anchor it with two  $\frac{3}{8}$ " x  $4\frac{1}{2}$ " anchor bolt and flat washer (Figure 9).
8. Once the yoke has been anchored, use a socket wrench and  $\frac{9}{16}$ " socket to tighten the anchor bolts (Figure 10).
9. Confirm the yoke is level and plumb. Shim as needed.



Fig. 7

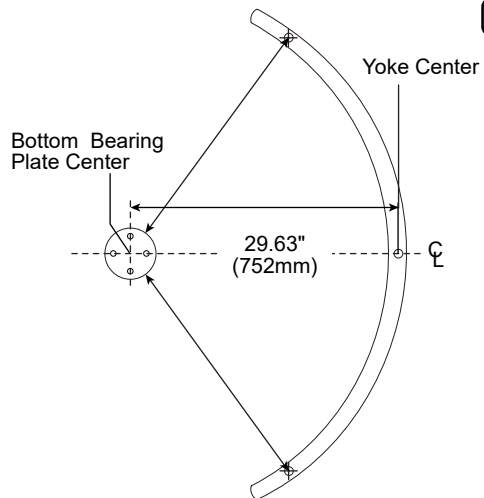

Fig. 8

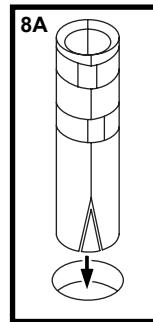

Fig. 9

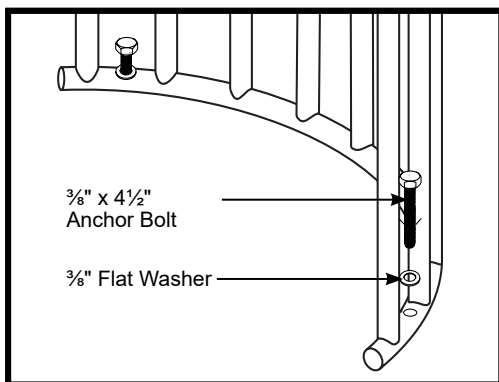
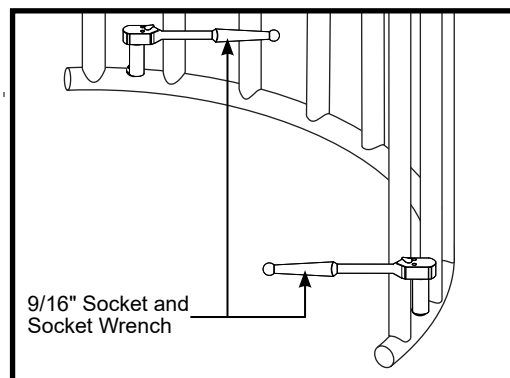

Fig. 10





### OV Installation

**NOTE**

STEPS AND DIMENSIONS SHOWN ARE FOR MST MODELS. SEE APPENDIX A-D FOR OTHER MODELS.



1. Reconfirm the centerline location for the OV (Figure 11).
2. While holding the OV in place, use a pencil and mark the center of all four anchoring holes in the base of the OV (Figure 12).
3. Using a 5/8" concrete drill bit, drill four anchor holes, 3" in depth, at the center of each marked location in Step 2.

**NOTES**

The anchor hole(s) must be clean before installing the anchor bolt(s). If the hole(s) are not clear of debris, the anchor bolt(s) may not tighten correctly.

If desired, conduit stub may be marked and installed at this time. Refer to the "Electrical Wiring" section.

4. Insert anchors into the drilled holes. The threaded end of the anchor must be inserted into the hole first. Use a hammer to tap the anchor into place, if needed. Ensure that the anchors are flush with the concrete floor.
5. Place the OV back over the anchor holes and anchor it with four 3/8" x 2 1/2" anchor bolts and flat washers (Figure 13).
6. Once the OV has been anchored, use a socket wrench and 9/16" socket to tighten the anchor bolts (Figure 14).
7. Confirm OV is level and plumb. Shim as needed.

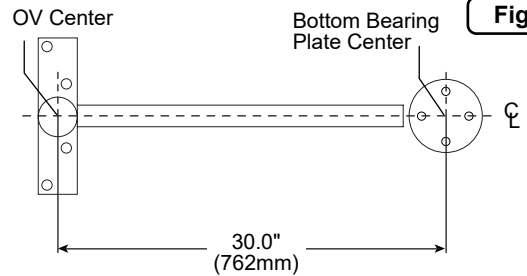

Fig. 11

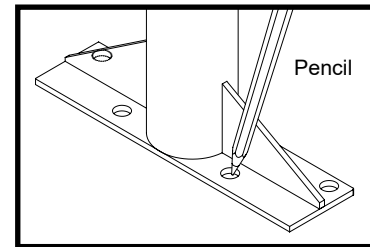

Fig. 12

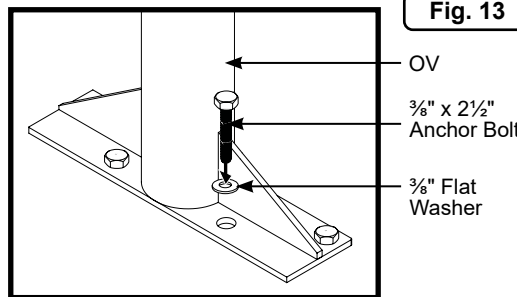

Fig. 13

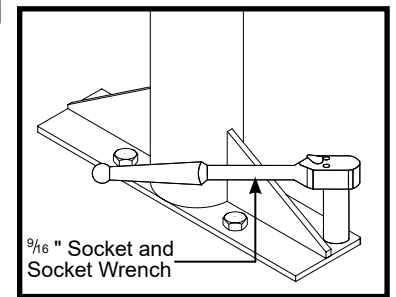
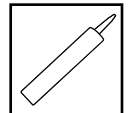

Fig. 14

### Roto Installation

**NOTE**

Prior to installing, liberally apply a coating of grease to the shaft, top of the bearing, sides of the bottom bearing plate and inside the bottom bearing plate (layer 1/4" to 1/2" in thickness). Applying grease as indicated will help protect against moisture and foreign matter penetrating the bearing area.



1. Attach the bottom bearing, collar facing up, to the lower end of the roto (Figure 15) by sliding the bottom bearing onto the mounting shaft (Figure 15A).

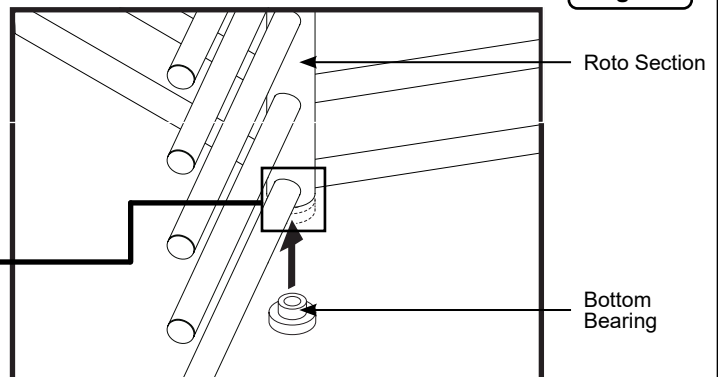
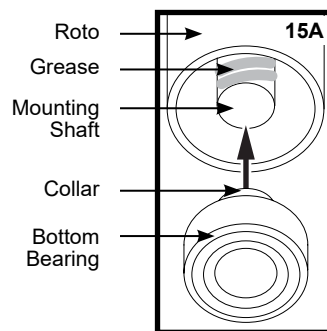

Fig. 15



### Roto Installation (Cont)

2. Apply grease, as instructed in the roto Installation note on the previous page. Lower the roto, bottom bearing first, into the bottom bearing plate (Figure 16). Wipe away any excess grease.
3. When complete, refer to Figure 17 for correct orientation.

Fig. 17

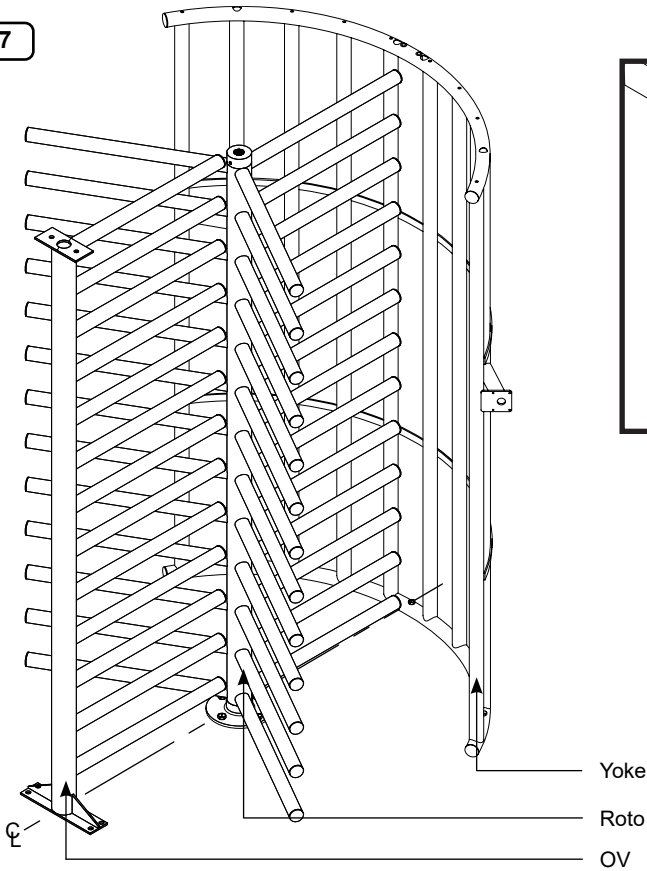
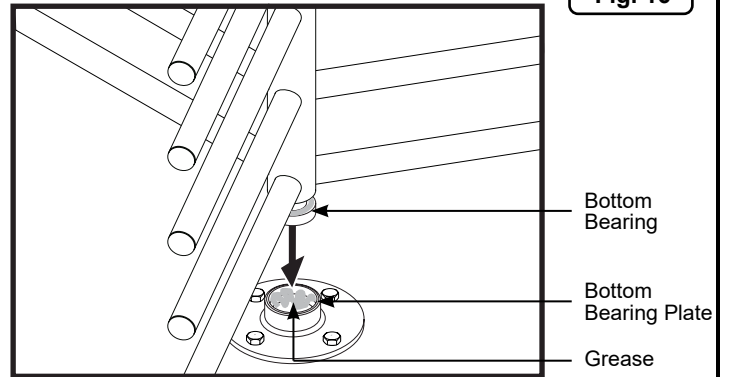

Fig. 16



### Top Channel Installation



A minimum of two people is required to complete the installation of top channel.



1. Remove the cover from the top channel using a 1/8" Allen wrench (Figure 18).
2. Determine orientation before installing the top channel.

**NOTE**

The end of the top channel with the power outlet attached to it must be mounted over the yoke. The end of the top channel with the large hole in the center and two smaller holes on either side must be mounted over the OV.

Fig. 18

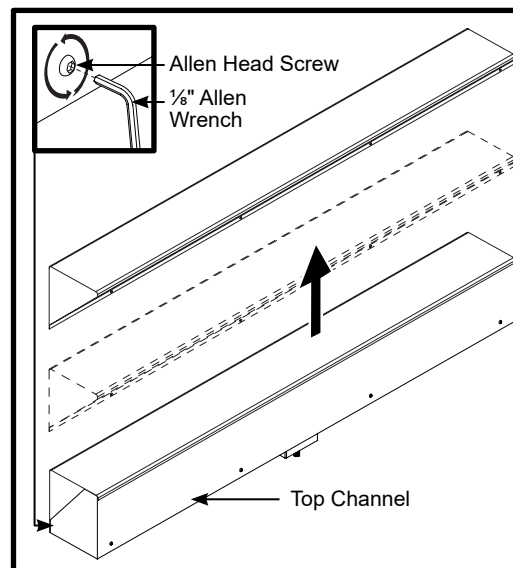



### Top Channel Installation (Cont)

3. With the help of two assistants, lift the top channel up and over roto, yoke and OV (Figure 19).

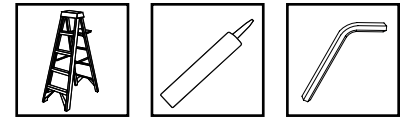

Fig. 19

**DANGER**

Be sure that the feeder wire and/or any access control pad wiring is out of the way and is not caught between the top channel and the yoke, roto or OV, as this may damage the wires.

4. Align the top channel spline shaft with the roto cavity and carefully lower the top channel spline shaft into the roto cavity (Figure 20).

**NOTE**

Apply grease to the end of the spline shaft before inserting.

5. Once the top channel is seated firmly in place, use an Allen wrench to tighten the set screw (Figure 20).
6. Confirm roto is level and plumb.

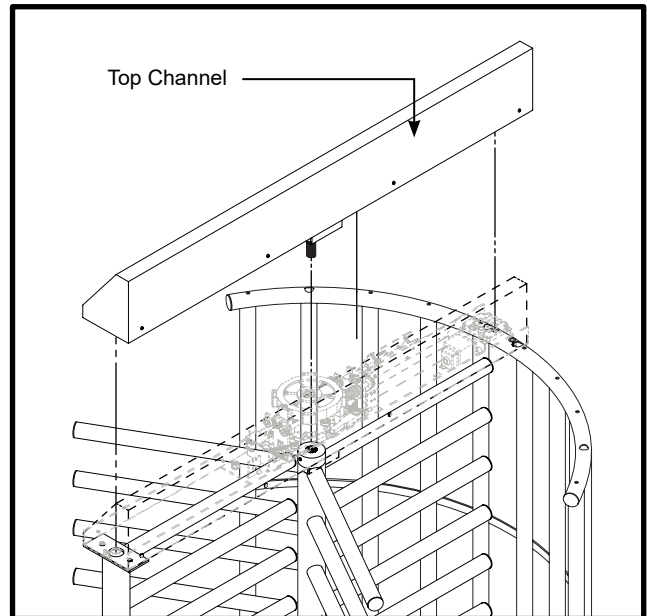
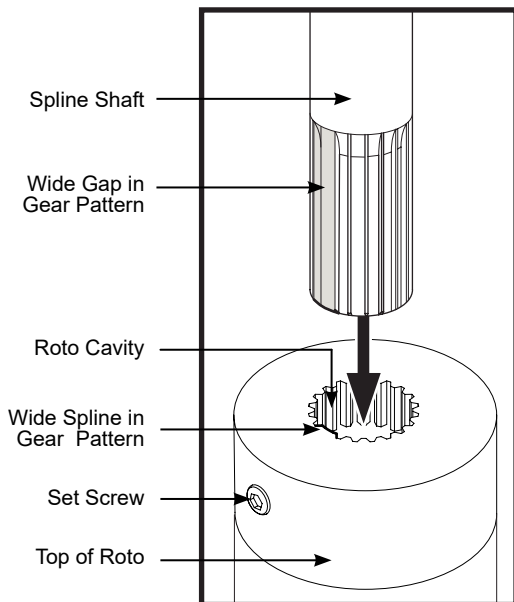
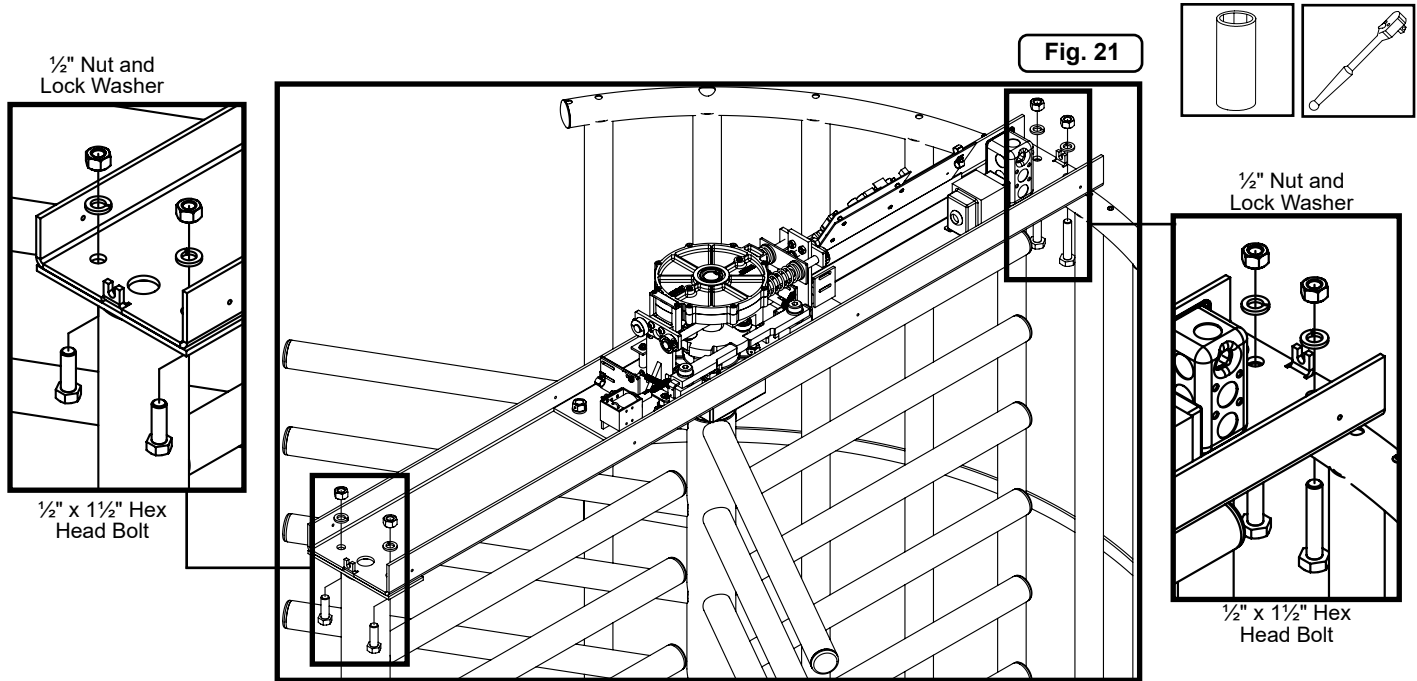

Fig. 20





## Top Channel Installation (Cont)



7. The top channel mounting holes are located at each end of the top channel (Figure 21).
  - A. Yoke Side - Insert two  $\frac{1}{2}$ " x  $2\frac{3}{4}$ " hex head bolts, from the underside of the top channel, up through the mounting holes and secure with two  $\frac{1}{2}$ " lock washers and two  $\frac{1}{2}$ " nuts (Figure 21A).
  - B. OV Side - Insert two  $\frac{1}{2}$ " x  $1\frac{1}{2}$ " hex head bolts, from the underside of the top channel, up through the mounting holes and secure with two  $\frac{1}{2}$ " lock washers and two  $\frac{1}{2}$ " nuts (Figure 21).
8. Hand tighten the top channel mounting hardware at this time using a  $\frac{3}{4}$ " socket wrench and a  $\frac{3}{4}$ " wrench.

## Guard Plate Installation

1. Slide the wide end of the guard plate, (notched end first) between the top channel and the top of the yoke (Figure 22).
2. Insert one  $\frac{1}{2}$ " x 1" hex head bolt and  $\frac{1}{2}$ " flat washer, from the underside of the guard plate, up through the top channel mounting hole and secure with one  $\frac{1}{2}$ " lock washer and one  $\frac{1}{2}$ " nut.
3. Finger tighten the guard plate mounting hardware at this time.

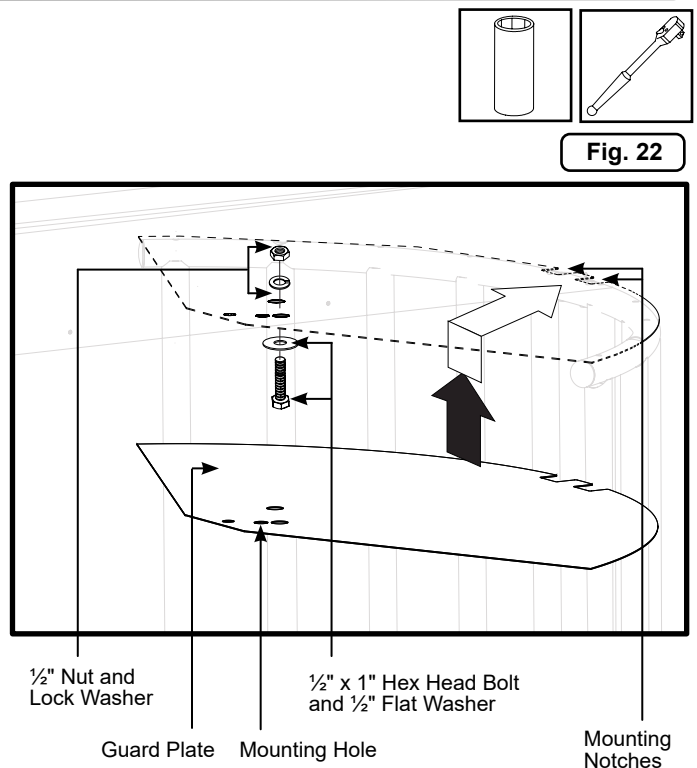



## Bearing Cover Installation

### NOTE

For illustration and clarity purposes only, the bearing cover illustrations are shown without the surrounding sections.

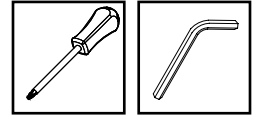

### Top Bearing Cover Installation

1. Place the two halves of the top bearing cover over the top bearing and align the mounting holes.
2. Using an Allen wrench, Insert and tighten the six 10-32 x 1/2" Allen head mounting screws (Figure 23).

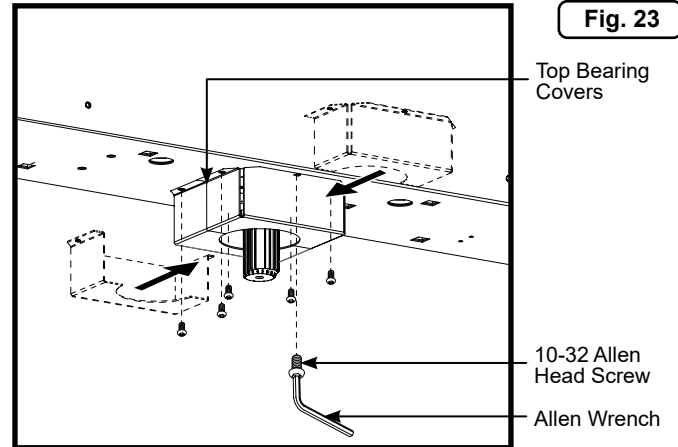

### Bottom Bearing Cover Installation

1. Place the two halves of the bottom bearing cover over the bottom bearing and align the mounting holes.
2. Using a screwdriver, tighten the two mounting screws (Figure 24).

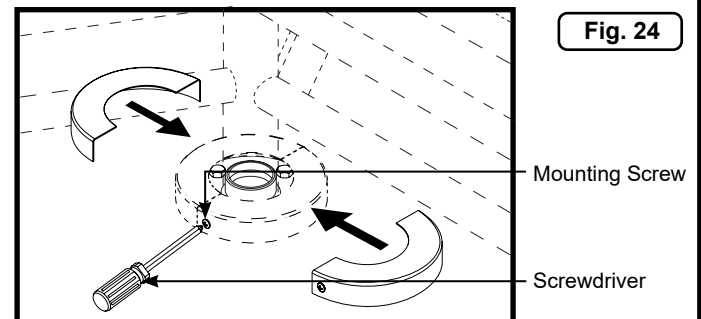



## Final Mechanical Installation Steps

### NOTE

Be sure the guard plate and the yoke are aligned properly and flush before performing the following step(s).

Be sure that the turnstile is level before performing the following step(s). If it is not level, use shims as needed.

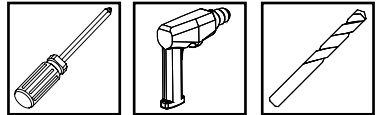

1. Ensure that all mounting hardware is tightened. The anchor bolts (11 total) and the top channel mounting bolts should be tightened to 40 ft-lbs using a torque wrench and appropriate sockets.
2. Using a drill and 9/64" drill bit, pre-drill six holes (three along each side of the yoke).
3. Insert and tighten six #10 x 3/4" Phillips pan head screws (Figure 25).
4. Test the roto for binding when it is functional. If there is binding, loosen the mounting hardware and adjust as needed.
5. Test the roto for binding. If no binding occurs, retighten all mounting hardware.

Fig. 25

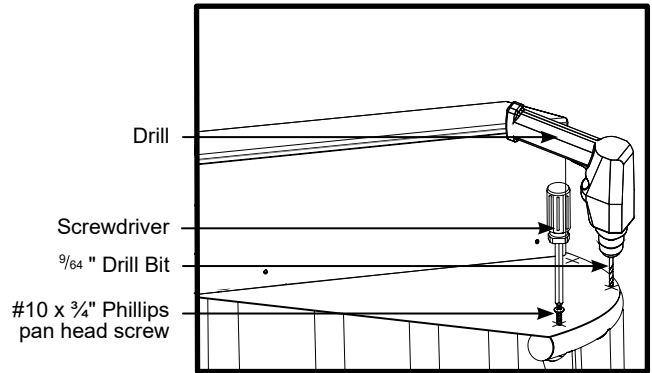

## Key Override Operation

### NOTE

When shipped, the keys are attached to the chassis on the inside of the top channel.

The key override switch manually unlocks the turnstile in the desired direction. Key override switches are installed in the top channel, on either side of the roto.

To engage the key override, turn the key 90°.

### NOTE

Remove keys when complete and store in a safe location. If the key override lock will not properly engage, please refer to the 'Troubleshooting' section.

This completes your installation of the MST.

If the MST is electrically controlled, please proceed to the "Electrical Wiring Instructions" section.

Fig. 26

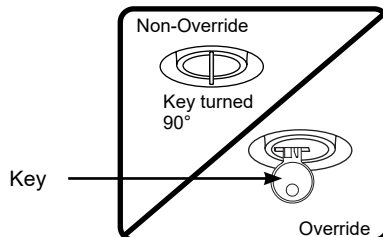
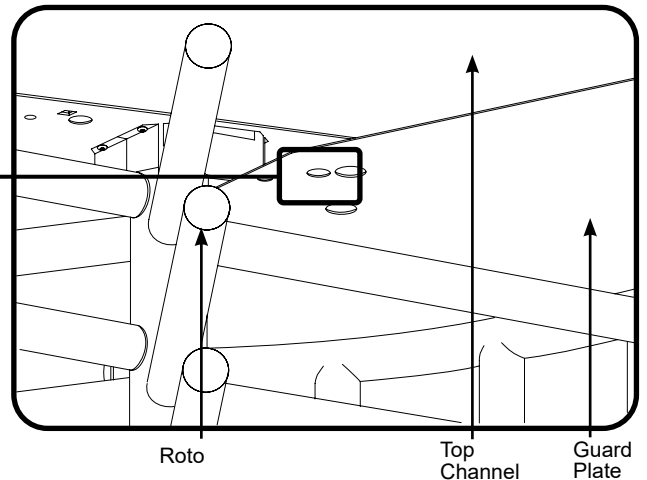

### NOTE

The key will always be parallel to the top channel in the override position.  
The key will always be perpendicular to the top channel in the non-override position.



# Conduit Instructions

For electric models, flex conduit can be run through the vertical tube of the OV. Also, conduit may be attached directly to the top channel cover. After completing primary power and access control wiring, plug all unused holes in the top channel.

## 1. OV Installation

Stub-up at the base of the OV and run conduit through the OV and top channel to the junction box. Flex conduit must be run all the way to the junction box. (Figure 27A).

## 2. Top Channel Cover Installation

Run conduit to the top channel cover in one of the locations shown in (Figure 27B). Punch conduit hole at least 2.5" from the bottom of the top channel lid. Conduit must be run all the way to the junction box.

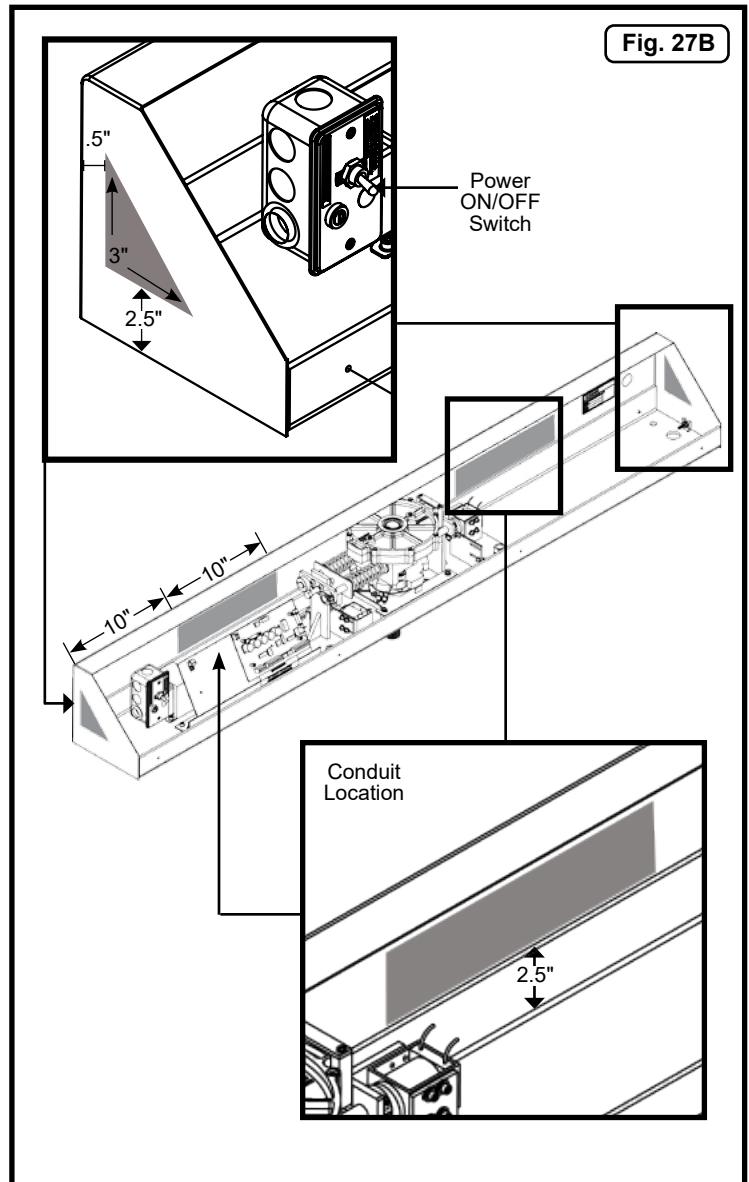
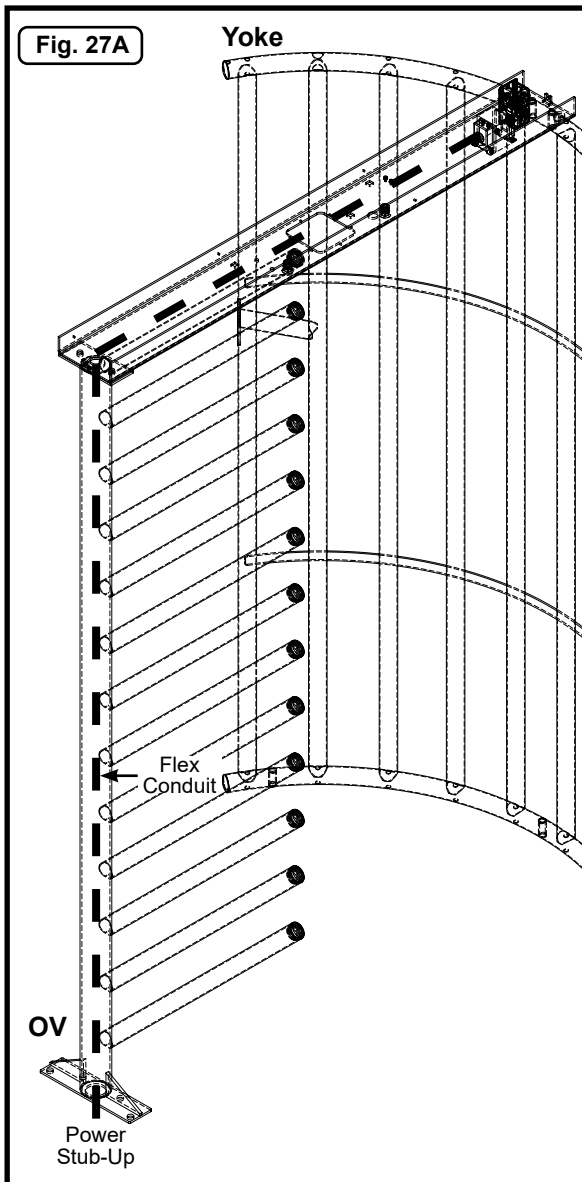



## Electrical Wiring Instructions

### ⚠ WARNING

Run permanent AC power wires to the unit. Primary side of transformer DC resistance is rated at 2.6-ohms. Use a licensed electrician to perform this procedure adhering to all local electrical codes.

### NOTE

In the event the transformer needs to be replaced, it must be replaced with Alvarado P/N 10-3008A (110V) or 10-3003F (220V) as specified in UL File BP20972, Projects 4787469780, 4787461699.

Use a licensed electrician for the following steps.

1. Remove the top channel cover.
2. Make sure the power on toggle switch is in the OFF position. If it is not, move the toggle switch to the OFF position (Figure 27B).
3. Using a screwdriver, remove the cover of the junction box.
4. Locate the power wires inside the junction box.
5. Run the primary power wires, coming in from either side of the top channel, through the knock-out.

### NOTE

The junction box housing has circular knock-outs on the side of the box. Remove the most appropriate knock-out.

6. Secure primary power wires to the provided pig-tail in the junction box and secure with wire nuts. See Figures 28A & B for 110V & 220V configuration.
7. Tuck the excess wire into the junction box and re-attach the junction box cover.
8. Once power has been established, route the access control wires.

### NOTE

If your model was purchased with the option of having a card reader installed, please refer to the installation instructions that come packaged with the card reader mounting plate.

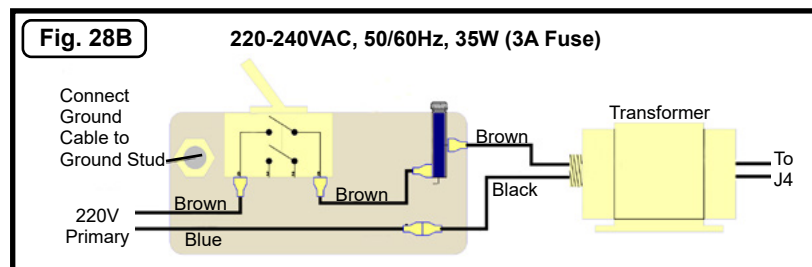
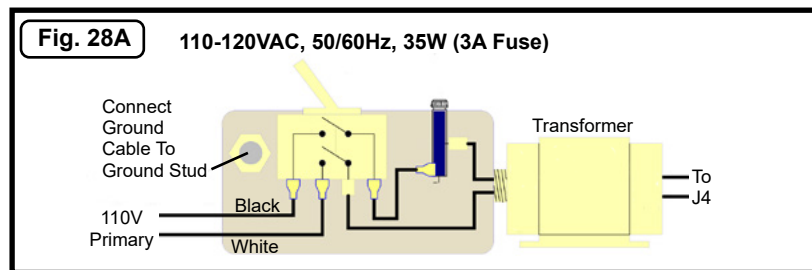



# Turnstile Control Board Layout

Fig. 29

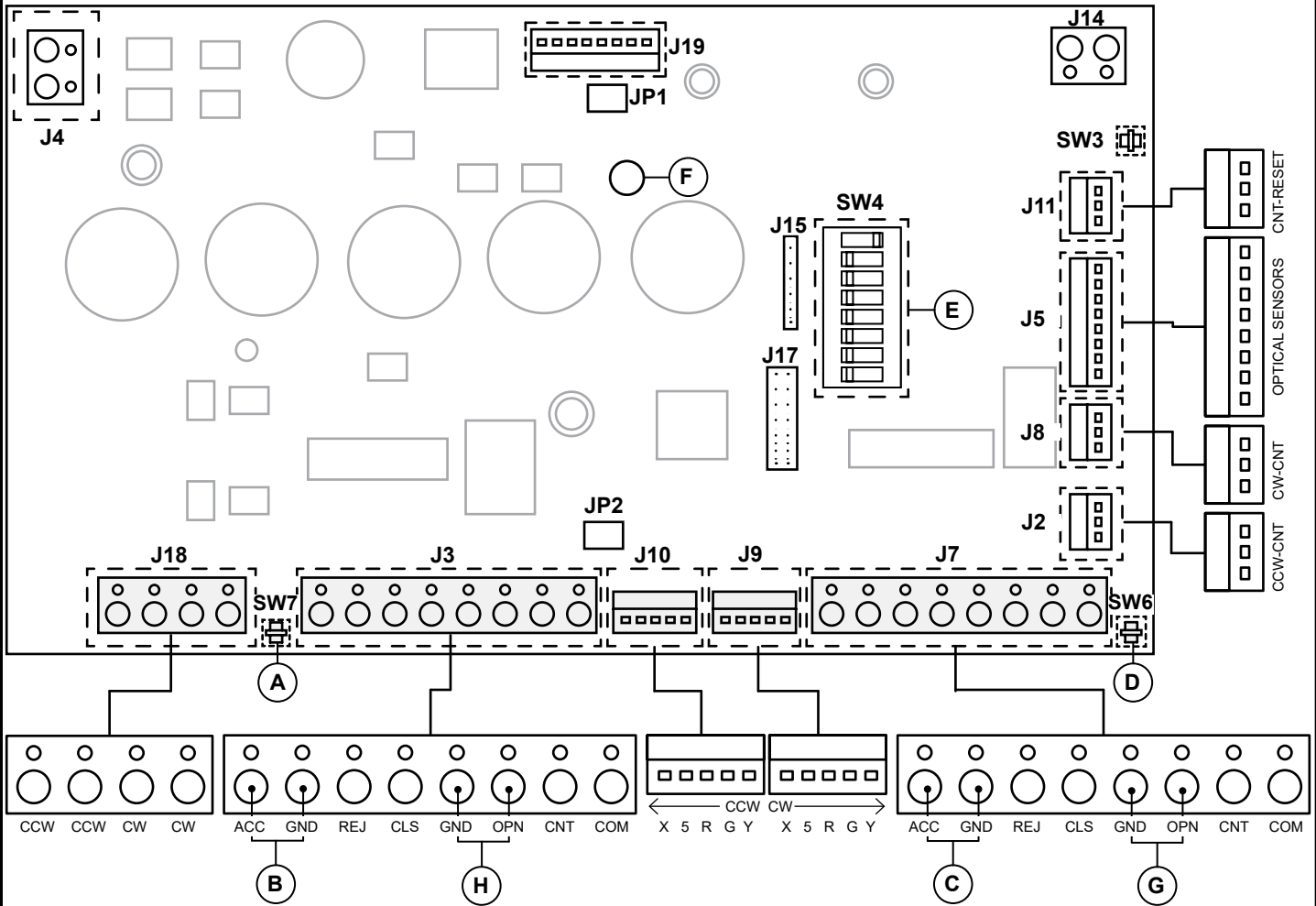

### SW4 Layout

Fig. 29A

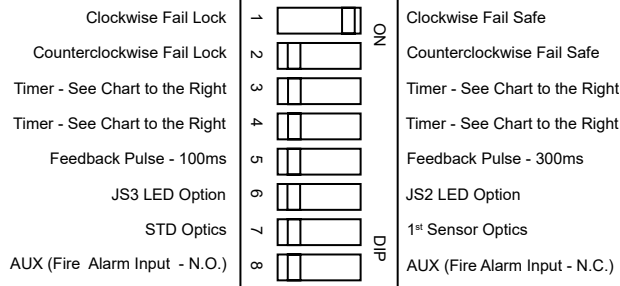

LEGEND	
Item	Name
A	CCW Test Activation Switch (SW7)
B	Access Control Activation - CCW
C	Access Control Activation CW
D	CW Activation Test Switch (SW6)
E	DIP Switches (SW4)
F	Green LED
G	Fire Alarm System Connection - CW
H	Fire Alarm System Connection - CCW

**NOTE**

Default DIP switch settings pictured above are for Fail-lock/Fail-safe configurations.

Fig. 29B

### Entry Time Adjusting Control Switch Settings

TIMED DELAY RESET TIMER (Positions T3 and T4)	T3	T4
5 seconds	ON	ON
10 seconds	ON	OFF
15 seconds	OFF	ON
20 seconds (Default)	OFF	OFF



## Terminal Descriptions

BOARD	NAME	DESCRIPTION	RATING	EXPLANATION
J18	CCW	Solenoid VDC wire connection - Counter Clockwise Direction	12 - 15.73VDC*, 1.53A	Connection for Counter Clockwise Solenoid. Universal polarity.
J18	CCW	Solenoid VDC wire connection - Counter Clockwise Direction	12 - 15.73VDC*, 1.53A	Connection for Counter Clockwise Solenoid. Universal polarity.
J18	CW	Solenoid VDC wire connection - Clockwise Direction	12 - 15.73VDC*, 1.53A	Connection for Clockwise Solenoid. Universal polarity.
J18	CW	Solenoid VDC wire connection - Clockwise Direction	12 - 15.73VDC*, 1.53A	Connection for Clockwise Solenoid. Universal polarity.
SW7	CCW Entry Activation Test Button	Allows user to test turnstile activation - Counter Clockwise Direction	N/A	Depressing button simulates input to J3 ACC, "Entry Accept". If turnstile solenoid "fires" after depressing button AND re-locks after a single rotation of the Roto or upon time out, the turnstile is functioning correctly in the Left Hand/Counter Clockwise Direction.
J3	ACC Entry Accept	"Card Authorized" input connection from the access control system - Counter Clockwise Direction	0VDC, 18mA	This connection is used to tell the turnstile to unlock. The ATC will accept a N.O. dry contact signal of .5 seconds to 2 seconds from the access control system and allow one rotation of the Roto before re-locking.
J3	GND Ground	Ground wire connection from the access control system - Counter Clockwise Direction	0VDC, 18mA	Ground wire connection position for ACC and REJ contact signal.
J3	REJ Entry Reject	"Card Reject" input connection from the access control system - Counter Clockwise Direction	0VDC, 18mA	This connection is used to tell the turnstile to remain locked. The access control system has determined that the card presented is unauthorized for entry.
J3	CLS Close Passage	Connection for placing turnstile in locked "CLOSED" status - Counter Clockwise Direction	0VDC, 18mA	Providing a continuous dry contact at this terminal places the turnstile in a locked "CLOSED" mode. This mode overrides the access control system operation. If status lights are installed (Location J19) the red light will be illuminated continuously.
J3	GND Ground	Ground wire connection for "OPN/CLS" lane control - Counter Clockwise Direction	0VDC, 18mA	Ground wire connection for "OPN/CLS" passage control.
J3	OPN Open Passage	Connection for Fire Alarm System, or placing turnstile in "OPEN" status - Counter Clockwise Direction.	0VDC, 18mA	Providing a continuous dry contact at this terminal places the turnstile in an "OPEN" mode. Typically, this terminal is used to connect the fire alarm system (normally open type) when the turnstile is configured for counterclockwise rotation in the exit direction.
J3	CNT Passage Count	Confirmation signal upon turnstile rotation - Counter Clockwise Direction	0VDC, 18mA	Outputs a dry contact upon rotation of the turnstile. This feature can be used to output a "count" signal to an external system such as Alvarado's GateWatch or to provide feedback to the access control system that a turnstile rotation has taken place.
J3	COM Passage Count	Confirmation signal upon turnstile rotation - Counter Clockwise Direction	0VDC, 18mA	Common dry contact connection for CNT count signal output. See J3 CNT description.
J10	X5RGY-CCW	Connection for Activation Lights - Counter Clockwise Direction	5VDC, 50mA	Connection for JS2 and JS3 activation lights.
J9	X5RGY-CW	Connection for Activation Lights - Clockwise Direction	5VDC, 50mA	Connection for JS2 and JS3 activation lights.
J7	ACC Entry Accept	"Card Authorized" input connection from the access control system - Clockwise Direction	0VDC, 18mA	This connection is used to tell the turnstile to unlock. The ATC will accept a N.O. dry contact signal of .5 seconds to 2 seconds from the access control system and allow one rotation of the Roto before re-locking.
J7	GND Ground	Ground wire connection from the access control system - Counter Clockwise Direction	0VDC, 18mA	Ground wire connection position for ACC and REJ contact signal.
J7	REJ Entry Reject	"Card Reject" input connection from the access control system - Counter Clockwise Direction	0VDC, 18mA	This connection is used to tell the turnstile to remain locked. The access control system has determined that the card presented is unauthorized for entry.

\* After approximately 4 seconds, voltage will drop to approximately 2.7VDC connected to the load of the solenoid.

**Terminal Descriptions (Cont)**

BOARD	NAME	DESCRIPTION	RATING	EXPLANATION
J7	GND Ground	Ground wire connection for "OPN/CLS" lane control - Clockwise Direction	0VDC, 18mA	Ground wire connection for "OPN/CLS" passage control.
J7	CLS Close Passage	Connection for placing turnstile in "OPEN" status - Counter Clockwise Direction	0VDC, 18mA	Providing a continuous dry contact at this terminal places the turnstile in a locked "CLOSED" mode. This mode overrides the access control system operation. If status lights are installed (Location J19) the red light will be illuminated continuously.
J7	OPN Open Passage	Connection for Fire Alarm System or placing turnstile in "OPEN" status - Clockwise Direction	0VDC, 18mA	Providing a continuous dry contact at this terminal places the turnstile in an "OPEN" mode. Typically, this terminal is used to connect the fire alarm system (normally open type) when the turnstile is configured for clockwise rotation in the exit direction (default).
J7	CNT Passage Count	Confirmation signal upon turnstile rotation - Clockwise Direction	0VDC, 18mA	Outputs a dry contact upon rotation of the turnstile. This feature can be used to output a "count" signal to an external system such as Alvarado's GateWatch or to provide feedback to the access control system that a turnstile rotation has taken place.
J7	COM Passage Count	Confirmation signal upon turnstile rotation - Clockwise Direction	0VDC, 18mA	Common dry contact connection for CNT count signal output. See J3 CNT description.
SW6	CW Entry Activation Test Button	Allows user to test turnstile activation - Clockwise Direction	N/A	Depressing button simulates input to J7 ACC. "Entry Accept". If turnstile solenoid "fires" after depressing button AND re-locks after a single rotation of the Roto or upon time out, the turnstile is functioning correctly in the Clockwise Direction.
J2	CCW-CNT	Output of contact closure upon turnstile rotation - Counter Clockwise Direction	1.06VDC, 5µA	Single throw, relay output for connection to Alvarado battery powered, digital counter.
J8	CW-CNT	Output of contact closure upon turnstile rotation - Clockwise Direction	1.06VDC, 5µA	Single throw, relay output for connection to Alvarado battery powered, digital counter.
J5	Optical Sensors	Connection for sensors	3.3VDC, 16.5mA	The ATC uses input from the sensors to monitor rotation of the Roto.
J11	CNT- RESET	Connection for counter reset key switch	1.06VDC, 5µA	N.O. contact connection if counter wires are attached to J2 and/or J8 connections. A 2-position electrical key switch is connected here to provide a reset to the individual counters.
SW3	Reset counters	Local Battery Counter Reset Switch	N/A	If counter wires are attached to the board (J2 and J8), depressing this button will reset the counters. If two counters are installed and wired, both counters will be reset.
J19	EL Light Boards Connector	Connection for EL light boards	12VDC, 242mA	If red/green status lights are used, the green light signifies that the turnstile is ready to accept an activation for the direction shown. When the CLS and GND connection is closed, the red light will be illuminated and signifies that the turnstile will not accept an activation. Refer to description for CLS on J3 and J7.
J4	Power Input	Connection for low-voltage power	13.5VAC, 4.33A	The ATC accepts 10VAC or 13.5VDC power. If primary power is not run to the turnstile, low-voltage power is connected here. The green ground wire must be grounded to the chassis.
JP1	EL Lights Voltage Jumper	Sets voltage supplied to the EL light boards.	N/A	Set voltage to 12VDC.
JP2	JS2/JS3 Lights Voltage Jumper	Sets voltage supplied to the JS2/JS3 light boards.	N/A	Set voltage to 5VDC.
J14	N/A	Not used.	N/A	N/A
J15	Program- ming Port	Not applicable to end-users.	N/A	N/A
J17	N/A	Not used.	N/A	N/A



## SW4 DIP Switch Descriptions

### SW4 Layout (Figure 29A)

LEFT / OFF	Switch Position	Switch Position	RIGHT / ON
Sets solenoid control for the Clockwise direction in fail lock configuration. Power is applied to solenoid upon activation signal to release lock arm for rotation.	<b>CWFL</b>	<b>FS</b>	Sets solenoid control for the Clockwise direction in fail safe configuration. Power is applied to solenoid for locked condition and removed upon activation signal to release lock arm for rotation.
Sets solenoid control for the Counter Clockwise direction in fail lock configuration. Power is applied to solenoid upon activation signal to release lock arm for rotation.	<b>CCWFL</b>	<b>FS</b>	Sets solenoid control for the Counter Clockwise direction in fail safe configuration. Power is applied to solenoid for locked condition and removed upon activation signal to release lock arm for rotation.
Adjusts automatic re-lock timing. See Figure 28A for settings.	<b>T3</b>	<b>T3ON</b>	Adjusts automatic re-lock timing. See Figure 28A for settings.
Adjusts automatic re-lock timing. See Figure 28A for settings.	<b>T4</b>	<b>T4ON</b>	Adjusts automatic re-lock timing. See Figure 28A for settings.
Sets Length of time of contact closure on CNT and COM feedback to 100ms.	<b>100</b>	<b>FBPL</b>	Sets Length of time of contact closure on CNT and COM feedback to 300ms.
Set switch to left when using Red/Yellow/Green Activation Lights.	<b>JS3</b>	<b>JS2</b>	Set switch to right when using Red/Green Activation Lights.
Sets operation to standard optical sensor configuration for passage feedback after second sensor detection.	<b>STD</b>	<b>ROFP</b>	Sets operation to custom optical sensor configuration for passage feedback on first sensor detection.
Configures OPN terminals as normally open (N.O.). OPN inputs are used for fire alarm / free passage modes.	<b>AUX</b>	<b>AUX</b>	Configures OPN terminals as normally closed (N.C.). OPN inputs are used for fire alarm / free passage modes.



## User Activation and Passage Instructions

Print and distribute this page to inform users how to properly operate the turnstile.

### NOTES

- Always walk slowly through the turnstile
- Always use caution when using the turnstile

Follow the steps below on how to use the turnstile.

1. The turnstile should always be in the “Home” position before access is requested (i.e. an access control card is presented to the card reader). If the turnstile is not in the “Home” position, manually reposition the roto section (the arms) to the “Home” position before requesting access (Figure 30).
2. Request access (i.e. present an access control card to the card reader) and activate the turnstile. Listen for the turnstile to unlock (the solenoid will “fire” and make a clicking sound) and (if applicable) look for the green activation light.
3. Immediately step into the turnstile (Figure 31). Keeping your arms extended, gently push on roto arm section “A” and slowly walk through the turnstile (Figure 31). Stay near the yoke and take short steps. Once you have traveled through the passage area move out of the way of the turnstile arms.

### CAUTION

Never grab roto arm section “C” and pull it in front of you. Doing this will result in the roto section stopping suddenly (after rotating 120°) before you are all of the way through the turnstile.

### CAUTION

After walking through the turnstile, the turnstile arms will continue to rotate, completing the 120° rotation. Taking long steps could cause the trailing arm section to strike your heels. Heel and arm guards are an option that can be purchased from Alvarado.

4. Step completely out of the turnstile.

### CAUTION

If a patron does not complete the full rotation before the predefined delay time-out period, the turnstile will re-lock. Based upon the actual position of the patron when the turnstile re-locks, the patron will either complete the full rotation or will be required to back out of the turnstile and initiate another entry access request.

Fig. 30

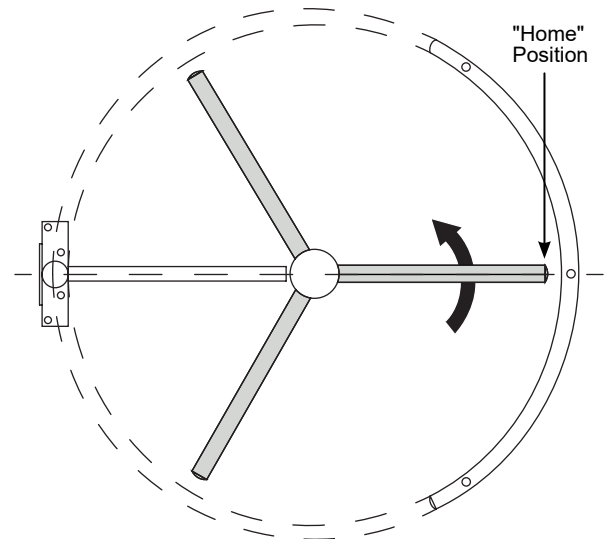
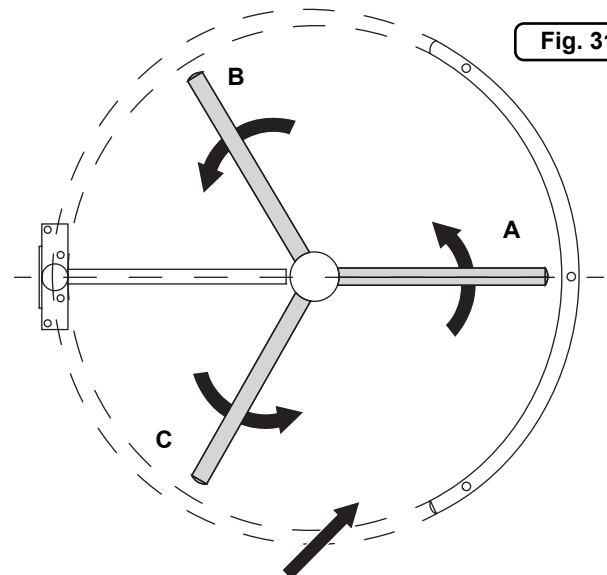

Fig. 31





## Post-Installation Checklist

### 1 Electrical

- Validate that electrical connections meet local code requirements.

### 2 Operation

- Validate key override operation.
- Ensure key overrides are in proper operational position.
- Validate turnstile operation in conjunction with the installed access system. Perform multiple activations and rotations in each direction.
- Ensure that desired outputs are attached and operational.

### 3 Attachment

- Check that mounting bolts and screws are secure and tightened per the requirements in this manual.
- Top and bottom bearing covers are installed.
- Top channel cover is in place.

### 4 Finish

- Stainless Steel (uncoated) – wipe down the entire turnstile with clean water or use the Alvarado recommended commercial products (see Cleaning and Maintenance Section).
- Stainless Steel (units with optional coating) – wipe down entire turnstile with clean water.
- Hot Dipped Galvanized – wipe down the stainless steel top channel as indicated above. Repair any damaged galvanized areas with zinc-rich paint following the manufacturer's instructions. An explanatory document describing the ASTM recommended repair process is available from the American Galvanizer Association website.
- Powder coated - wipe down entire turnstile with clean water. Repair areas that may have been damaged during the installation process. Touch up paint can be purchased from Alvarado.
- Acrylic - wipe down acrylic surfaces with Alvarado recommended commercial products (see Cleaning and Maintenance Section).

### 5 User Instructions

- Train responsible personnel on turnstile operation.
- Provide the User Activation and Passage Instructions contained in this manual to responsible personnel.

### 6 Manual Handoff

- Provide this manual to responsible personnel.



# Troubleshooting

## NOTES

The steps contained in this Troubleshooting section are the most common issues that may arise during the operation of the unit. If the provided steps do not resolve the issue, please contact Alvarado Technical Support (909-591-8431).

The built-in key locks provide override functionality. Verify that locks are not in the override position before performing any troubleshooting procedures. Please see "Key Override Operation" section for instructions.

## WARNING

If at any time during the troubleshooting process you will be exposed to live wires (i.e. opening the junction box), ensure the turnstile is powered off at the supply circuit before beginning.

### FAIL-SAFE / FAIL-LOCK CONFIGURATION

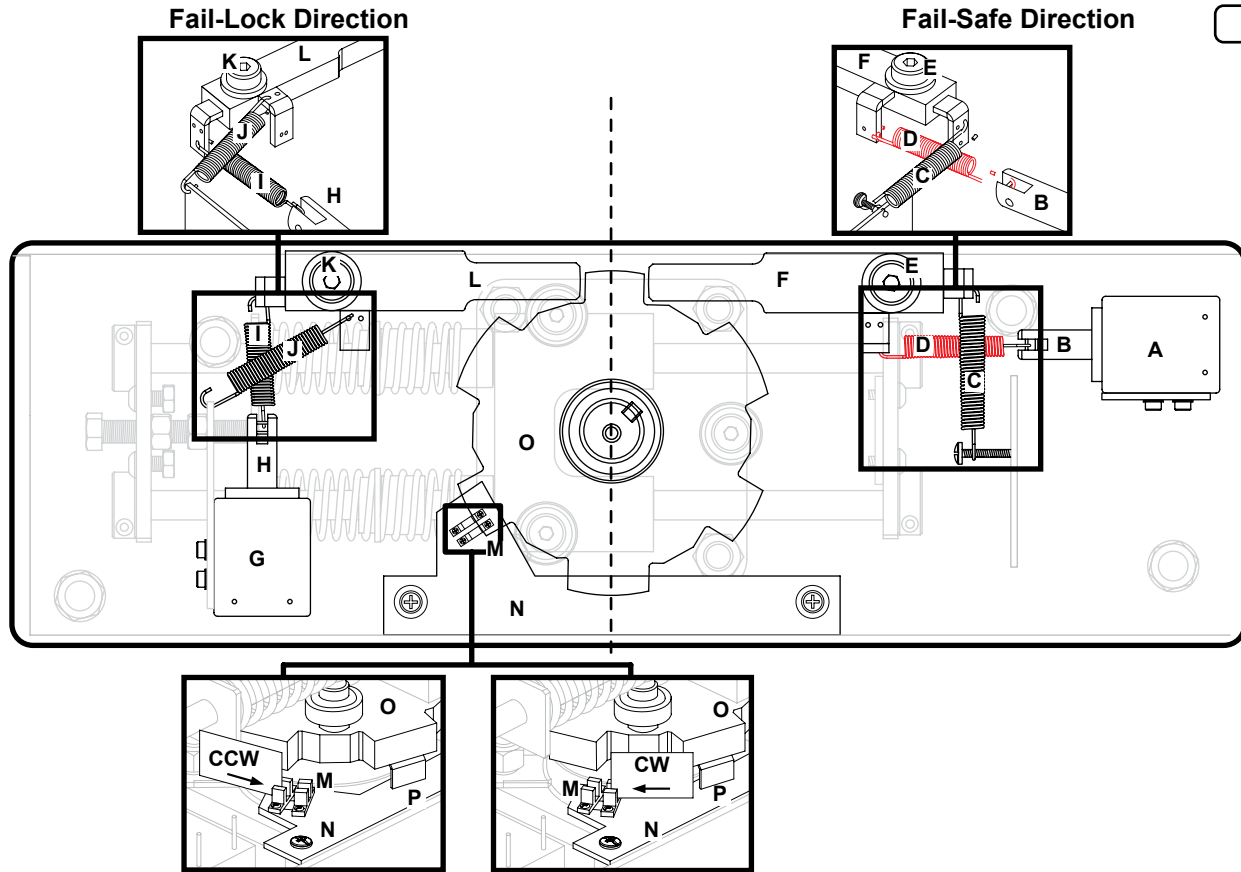

Fig. 32

A	Solenoid (Fail-safe)	I	Solenoid Spring (Fail-lock)
B	Solenoid Plunger (Fail-safe)	J	Return Spring (Fail-lock)
C	Return Spring (Fail-safe)	K	Lock Arm Mounting Bolt (Fail-lock)
D	Solenoid Spring (Fail-safe)	L	Lock Arm (Fail-lock)
E	Lock Arm Mounting Bolt (Fail-safe)	M	Optical Sensors
F	Lock Arm (Fail-safe)	N	Optical Sensor Mounting Plate
G	Solenoid (Fail-lock)	O	Encoder Wheel
H	Solenoid Plunger (Fail-lock)	P	Encoder Flag



## Troubleshooting (Cont)

### Fail-safe direction will not unlock

<b>Power Issues</b>		
Cause	Solution	Reference
Green LED is OFF	<ol style="list-style-type: none"> <li>1. Verify that the power switch is in the ON position and that primary power is provided to the turnstile.</li> <li>2. Check the fuse; replace if bad.</li> <li>3. Check primary power input contacts (J4) on the control board are secure and tight.</li> </ol> <p>If the above steps above did not resolve the issue, contact Technical Support.</p>	<p>Fig. 21A - Power switch is located on the J-box inside the Top Channel.</p> <p>Fig. 21A - Fuse is located on the J-box inside the Top Channel.</p> <p>Fig. 28</p>
<b>Mechanical Issues</b>		
Cause	Solution	Reference
Incorrect springs	Verify that the springs on your unit are identical to the springs used in the illustration.	Fig. 32 (C) (D)
Springs attached incorrectly	Verify that the springs are attached correctly and in the correct mounting holes. Mounting hole locations on unit should match the locations that are shown in the illustration.	Fig. 32 (C) (D)
Incorrect spring tension	Depending on manufacturing date, adjust either the solenoid position or lock arm tab.	Appendix E
Lock arm binding or sticking	Clean and lubricate (see "Lubrication" section). If the lock arm is still binding, contact Technical Support.	Fig. 32 (F)
Solenoid plunger is binding	<ol style="list-style-type: none"> <li>1. Check for and remove any debris from the solenoid plunger and cavity area.</li> <li>2. Use an alcohol-moistened Q-tip to clean the solenoid plunger. Do not use water or lubricate the solenoid plunger. The solenoid is designed for dry operation.</li> </ol>	Fig. 32 (A) (B)
Key Override will not engage	Confirm key override is fully engaging with lock arm. Adjust as needed.	Appendix F
<b>Electronic Issues</b>		
Cause	Solution	Reference
Access Control / Control Board	<ol style="list-style-type: none"> <li>A. Disconnect all wires from terminal blocks J3 and J7.</li> <li>B. Press the test switch (SW6 or SW7) and note if lock arm unlocks.</li> <li>C. If the lock arm unlocks, then the turnstile is operating correctly. The issue is most likely with the access control system. Contact Technical Support.</li> </ol>	<p>Fig. 28 (J7) (J3)</p> <p>Fig. 28 (A) (D)</p>

**If the steps listed above did not solve the issue, contact Technical Support.**

### Fail-safe direction will not re-lock

<b>Power Issues</b>		
Cause	Solution	Reference
Green LED is OFF	<ol style="list-style-type: none"> <li>1. Verify that the power switch is in the ON position and that primary power is provided to the turnstile.</li> <li>2. Check the fuse; replace if bad.</li> <li>3. Check primary power input contacts (J4) on the control board are secure and tight.</li> </ol> <p>If the above steps above did not resolve the issue, contact Technical Support.</p>	<p>Fig. 21A - Power switch is located on the J-box inside the Top Channel.</p> <p>Fig. 21A - Fuse is located on the J-box inside the Top Channel.</p> <p>Fig. 28</p>
<b>Mechanical Issues</b>		
Cause	Solution	Reference
Incorrect springs	Verify that the springs on your unit are identical to the springs used in the illustration.	Fig. 32 (C) (D)
Springs attached incorrectly	Verify that the springs are attached correctly and in the correct mounting holes. Mounting hole locations on unit should match the locations that are shown in the illustration.	Fig. 32 (C) (D)
Incorrect spring tension	Depending on manufacturing date, adjust either the solenoid position or lock arm tab.	Appendix E
Lock arm binding or sticking	Clean and lubricate (see "Lubrication" section). If the lock arm is still binding, contact Technical Support.	Fig. 32 (F)
Solenoid plunger is binding	<ol style="list-style-type: none"> <li>1. Check for and remove any debris from the solenoid plunger and cavity area.</li> <li>2. Use an alcohol-moistened Q-tip to clean the solenoid plunger. Do not use water or lubricate the solenoid plunger. The solenoid is designed for dry operation.</li> </ol>	Fig. 32 (A) (B)
Key Override will not engage	Confirm key override is fully engaging with lock arm. Adjust as needed.	Appendix F

**Troubleshooting (Cont)****Fail-safe direction will not re-lock (cont)**

<b>Electronic Issues</b>		
Cause	Solution	Reference
Optical sensors are dirty	Use an alcohol-moistened Q-tip to clean the optical sensor(s) and retest.	Fig. 32 (M)
Optical sensors misaligned	Verify that cam flag passes freely through the optical sensor assembly.	Fig. 32 (P)
Access Control / Control Board	A. If the 'OPN' signal is connected to the access control system, verify that the 'OPN' signal is not being provided with a continuous dry contact. B. Press SW6 and swipe a business card clockwise through the optical sensors. C. If the unit re-locks, the problem lies with the access control system. D. If the unit does not re-lock, but re-locks after time out, proceed with optical sensors troubleshooting.	Fig. 28 (J3) (J7) (See Terminal Descriptions - J3 'OPN' on Page 17 J7 'OPN' on Page 18)
Optical sensors are installed incorrectly	A. Press SW6 and swipe a business card <u>clockwise</u> through the optical sensors. B. The green LED on the control board should turn OFF, and the unit should re-lock. If the unit re-locks, then optical sensors are installed correctly. C. If the unit does not re-lock, press SW6 again and swipe a business card <u>counterclockwise</u> through the optical sensors. D. If the green LED on the control board turns OFF, and the unit re-locks, then the optical sensors are installed incorrectly. E. Using a Phillips head screwdriver, remove the optical sensors from the optical sensor mounting plate and switch the mounting positions. Repeat step A. <b>NOTE:</b> The business card must pass through both optical sensors for a correct reading.	Fig. 28 (D) (F) Fig. 32 (M)  Fig. 32 (M) (N)
Optical sensors are bad	If the steps above did not resolve the problem, the issue most likely lies with the optical sensors. Please contact Technical Support.	

**If the steps listed above did not solve the issue, contact Technical Support.**

**Fail-lock direction will not unlock**

<b>Power Issues</b>		
Cause	Solution	Reference
Green LED is OFF	1. Verify that the power switch is in the ON position and that primary power is provided to the turnstile.  2. Check the fuse; replace if bad.  3. Check primary power input contacts (J4) on the control board are secure and tight.  If the above steps above did not resolve the issue, contact Technical Support.	Fig. 21A - Power switch is located on the J-box inside the Top Channel.  Fig. 21A - Fuse is located on the J-box inside the Top Channel.  Fig. 28
<b>Mechanical Issues</b>		
Cause	Solution	Reference
Incorrect springs	Verify that the springs on your unit are identical to the springs used in the illustration.	Fig. 32 (I) (J)
Springs attached incorrectly	Verify that the springs are attached correctly and in the correct mounting holes. Mounting hole locations on unit should match the locations that are shown in the illustration.	Fig. 32 (I) (J)
Incorrect spring tension	Depending on manufacturing date, adjust either the solenoid position or lock arm tab.	Appendix E
Lock arm binding or sticking	Clean and lubricate (see "Lubrication" section). If the lock arm is still binding, contact Technical Support.	Fig. 32 (L)
Solenoid plunger is binding	1. Check for and remove any debris from the solenoid plunger and cavity area. 2. Use an alcohol-moistened Q-tip to clean the solenoid plunger. Do not use water or lubricate the solenoid plunger. The solenoid is designed for dry operation.	Fig. 32 (G) (H)
Key Override will not engage	Confirm key override is fully engaging with lock arm. Adjust as needed.	Appendix F
<b>Electronic Issues</b>		
Cause	Solution	Reference
Access Control / Control Board	A. Disconnect all wires from terminal blocks J3 and J7. B. Press the test switch (SW6 or SW7) and note if lock arm unlocks. C. If the lock arm unlocks, then the issue lies with the access control system. Contact Technical Support.	Fig. 28 (J3) (J7) Fig. 28 (A) (D)

**If the steps listed above did not solve the issue, contact Technical Support**



## Troubleshooting (Cont)

### Fail-lock direction will not re-lock

Power Issues		
Cause	Solution	Reference
Green LED is OFF	<ol style="list-style-type: none"> <li>1. Verify that the power switch is in the ON position and that primary power is provided to the turnstile.</li> <li>2. Check the fuse; replace if bad.</li> <li>3. Check primary power input contacts (J4) on the control board are secure and tight.</li> </ol> If the above steps above did not resolve the issue, contact Technical Support.	Fig. 21A - Power switch is located on the J-box inside the Top Channel.  Fig. 21A - Fuse is located on the J-box inside the Top Channel.  Fig. 28
Mechanical Issues		
Cause	Solution	Reference
Incorrect springs	Verify that the springs on your unit are identical to the springs used in the illustration.	Fig. 32 (I) (J)
Springs attached incorrectly	Verify that the springs are attached correctly and in the correct mounting holes.	Fig. 32 (I) (J)
Incorrect spring tension	Depending on manufacturing date, adjust either the solenoid position or lock arm tab.	Appendix E
Lock arm binding or sticking	Clean and lubricate (see "Lubrication" section). If the lock arm is still binding, contact Technical Support.	Fig. 32 (L)
Key Override will not engage	Confirm key override is fully engaging with lock arm. Adjust as needed.	Appendix F
Electronic Issues		
Cause	Solution	Reference
Optical sensors are dirty	Use an alcohol-moistened Q-tip to clean the optical sensor(s) and retest.	Fig. 32 (M)
Optical sensors misaligned	Verify that cam flag passes freely through the optical sensor assembly.	Fig. 32 (P)
Access Control / Control Board	<ol style="list-style-type: none"> <li>A. If the 'OPN' signal is connected to the access control system, verify that the 'OPN' signal is not being provided with a continuous dry contact.</li> <li>B. Press SW7 and swipe a business card counterclockwise through the optical sensors.</li> <li>C. If the unit re-locks, the problem lies with the access control system.</li> <li>D. If the unit does not re-lock, but re-locks after time out, proceed with optical sensors troubleshooting.</li> </ol>	Fig. 28 (J3) (J7) (See Terminal Descriptions - J3 'OPN' on Page 17 J7 'OPN' on Page 18)
Optical sensors are installed incorrectly	<ol style="list-style-type: none"> <li>A. Press SW7 and swipe a business card <u>counterclockwise</u> through the optical sensors.</li> <li>B. The green LED on the control board should turn OFF, and the unit should re-lock. If the unit re-locks, then optical sensors are installed correctly.</li> <li>C. If the unit does not re-lock, press SW7 again and swipe a business card <u>clockwise</u> through the optical sensors.</li> <li>D. If the green LED on the control board turns OFF, and the unit re-locks, then the optical sensors are installed incorrectly.</li> <li>E. Using a Phillips head screwdriver, remove the optical sensors from the optical sensor mounting plate and switch the mounting positions. Repeat step A.</li> </ol> <p><b>NOTE:</b> The business card must pass through both optical sensors for a correct reading.</p>	Fig. 28 (A) (F) Fig. 32 (M)  Fig. 32 (M) (N)
Optical sensors are bad	If the steps above did not resolve the problem, the issue most likely lies with the optical sensors. Please contact Technical Support.	

**If the steps listed above did not solve the issue, contact Technical Support**

### SPARE PARTS KITS

Item Number	Description	Document ID
50-04-2058A	MSTX Optical Sensor Assembly Kit	SPD3168
50-04-8693-2	MST/MSTX Speed Governor Kit	SPD3165
50-10-1070	Solenoid (12VDC) Kit	SPD3159
50-10-7821	MSTX-EDCX Board Driver Kit	SPD3158
50-MST-BK	MST Lock Arm, Bolt and BRG Kit	SPD3150
50-MST-LA	MST/MSTX Lock Arm Kit	SPD3148
50-MST-S1	MST/MSTX Spring Kit	SPD3147

Spare parts kits pricing and additional kits are available by contacting Technical Support. Commonly used kits are listed below.



# Troubleshooting (Cont)

## Self-Centering Adjustment

Fig. 33

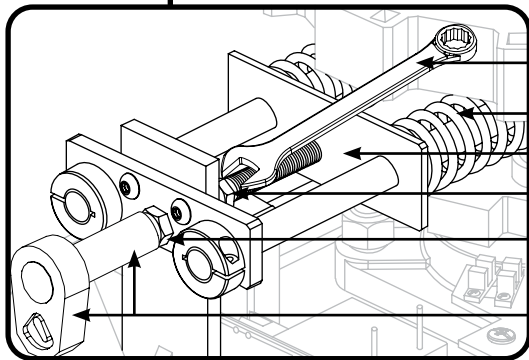
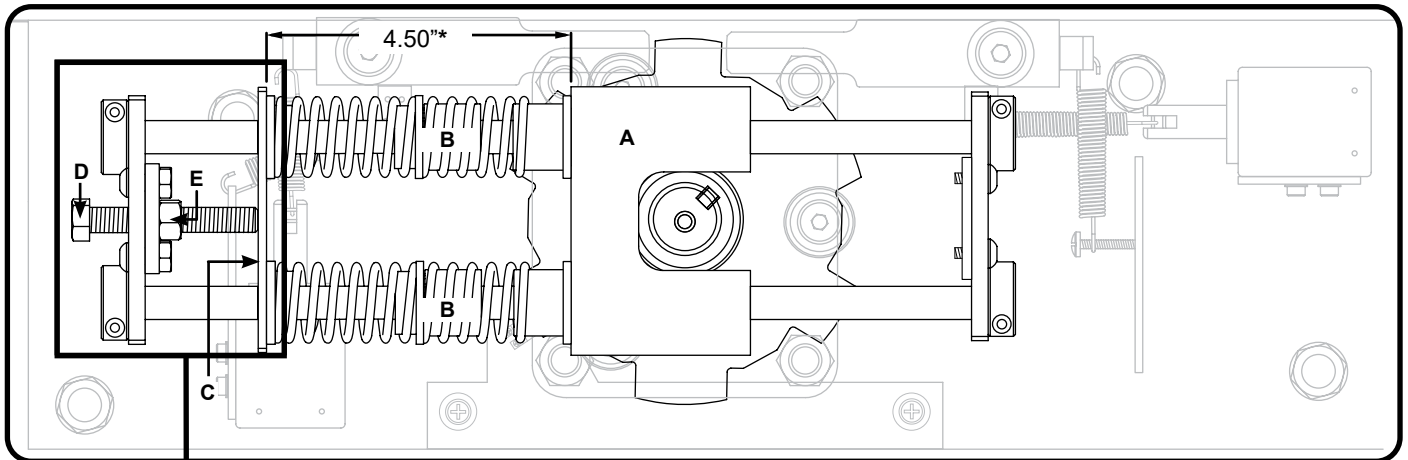

- 9/16" Wrench
- Tension Spring
- Back Plate
- Lock Nut
- Lock Bolt
- 9/16" Socket and Socket Wrench

A	Centering Shoe
B	Tension Springs
C	Back Plate
D	Lock Bolt
E	Lock Nut

\* Dimension shown with Roto in the "home" position (no-load on tension springs).

Tools: 9/16" Open-end wrench; 9/16" socket and socket wrench; tape measure

### **WARNING**

In the resting position, the distance from the centering shoe to the back plate is factory-set at 4.00", which is appropriate for most applications. If desired, this distance may be increased up to 4 3/8" (± 1/16"). Increasing the distance will allow the turnstile to rotate with less effort.

### **NOTE**

If the distance is exceeded, self-centering may not operate correctly.

Issue	Solution	Reference
Customer would like the turnstile to rotate with less pushing force.	<p>The pushing force required to rotate the turnstile is factory set to be suitable for most installations. To lessen the pushing force required to rotate the turnstile, adjust as follows:</p> <ol style="list-style-type: none"> <li>1. Locate the lock bolt and lock nut on the back plate.               <ul style="list-style-type: none"> <li>A. Loosen the lock nut with the 9/16" wrench while holding the lock bolt in place with the 9/16" socket and socket wrench.</li> <li>B. Once the lock nut has been loosened, unscrew the lock bolt 3 turns.</li> <li>C. Confirm smoother operation. If no noticeable change is detected, repeat steps A and B.</li> </ul> </li> <li>2. Once the self-centering tension has been adjusted, tighten all hardware. Perform approximately 10 rotations to confirm that the roto self-centers prior to closing the top channel cover.</li> </ol>	Fig. 33 (C) (D) (E)

**If the steps listed above did not solve the issue, contact Technical Support**



## Cleaning and Maintenance

The frequency of interior maintenance will depend on how often the turnstile is used, the type of personnel using the turnstile and the environment. Installed turnstiles should be inspected once during the first 30 days after installation. Thereafter, follow the maintenance schedule on the following pages. This schedule is based on what we would call a typical installation – which is a temperate climate where weekly use is up to 7500 activations. If use exceeds this threshold, personnel are abusive to the turnstile or the turnstiles are installed in harsh outdoor environments (such as coastal areas, chemical or refinery plants, very hot or cold locations, or extremely dusty environments), consider increasing the frequency of maintenance to a level suitable for your application.

### Galvanized Finishes

A hot dipped galvanized finish is an industrial coating designed to provide corrosion protection. Aesthetic considerations are secondary. Finish irregularities are a natural result of the hot dipped galvanizing process. The appearance of a hot dipped galvanized coating can vary depending on the size and shape of the coated object, as well as from piece to piece or section to section within the same piece. Various appearances for hot dipped galvanized steel (all acceptable under appropriate ASTM standards) include bright and shiny, spangled or mottled, matte gray, or a combination of various conditions. In most instances the appearance of hot dipped galvanized material has no effect on the primary purpose of the finish (corrosion protection) and over time and exposure to the environment, all galvanized finishes will take on a uniform matte gray appearance.

Periodic cleaning of galvanized finishes is recommended. To clean galvanized finishes use a neutral (non-alkaline) detergent, such as a car shampoo, clean warm water and soft brush. Abrasive cleaners, steel wool and chemical cleaning products should not be used. Rinse the surface after cleaning.

Damaged galvanized areas can be treated or touched up with zinc-rich paint. Use an organic cold galvanizing compound following the manufacturer's instructions. An explanatory document describing the ASTM recommended repair process is available from the American Galvanizer Association website.

### Stainless Steel Finishes

Stainless steel is a corrosion resistant chromium/nickel alloy steel that is strong and durable. However, it is not rustproof, particularly in harsh environments. In addition to actual damage, stainless steel can appear to rust when contaminated through contact with carbon steel. This contact can come from tools, adjacent mild steel, fasteners, particulate or through contact with hard water (which can leave spotting and staining on stainless steel). The most common method of contamination in windy, dusty and/or industrial environments is from steel and mineral particles that "land" on the stainless material. Mild steel naturally adheres to a stainless steel surface (due to iron-to-iron affinity). Grained material and weld areas are common areas where foreign particles are trapped. In all these cases, it is generally the steel residue, not the stainless material itself, which rusts initially. Left untreated, however, damage to the stainless surface itself can occur.

Regular cleaning is the best way to maintain any stainless steel finish. The goal of a cleaning program should be to clean the surface, keeping the stainless steel's protective chromium oxide layer intact. The frequency of cleaning will depend on the environment.

Regular cleaning can be accomplished by rinsing the stainless steel surface with fresh water to wash away accumulated chemicals, materials and particulates. Wipe dry with a clean cloth. Especially try to clean equipment immediately after contact with chlorides (chlorine powder, salt melt, seawater, etc.).

For embedded deposits a neutral detergent, such as a car shampoo, clean warm water and a soft brush can be used. Rinse the surface after cleaning. Never use steel wool. MAAS also makes an excellent stainless steel cleaner in a spray form, MAAS Stainless Steel & Chrome Cleaner, available from the MAAS website ([www.maasinc.com](http://www.maasinc.com)). All the products listed below can also be used for general cleaning.



## Cleaning and Maintenance (Cont)

### Stainless Steel Finishes (Cont)

For stubborn stains, heavy spotting and rust, our #1 recommendation is MAAS Metal Polish (in the liquid form). This is hands down the best product we have used. Follow the manufacturer's directions but in brief: (1) wipe down excess dirt from the turnstile; (2) apply polish to the metal; (3) polish in the direction of the grain with a super fine (0000) or fine (000) synthetic steel wool (depending on the level of tarnish); (4) wipe clean; (5) repeat steps 2 - 4 until clean. MAAS Metal Polish (liquid) is available from the MAAS website ([www.maasinc.com](http://www.maasinc.com)). Synthetic steel wool can generally be found at home improvement centers or online at Amazon.com. Again, never use steel wool.

Another product that is good is a product called Hope's Perfect Sink ([www.hopecompany.com](http://www.hopecompany.com)). The Perfect Sink product can be purchased at Lowe's, OSH and Amazon.com. Follow the directions on the bottle.

Rusted surfaces and even damaged pitted surfaces can generally be cleaned with the MAAS product but highly damaged areas may require chemical passivation. To chemically passivate stainless steel, Alvarado recommends the use of a citric acid product, CitriSurf2310, available from Stellar Solutions ([www.citrisurf.com](http://www.citrisurf.com)). This product is especially formulated to clean and passivate stainless steel and can be used in the field. Follow the manufacturer's directions.

Even with periodic cleaning, it is possible that periodic chemical passivation will be required to maintain stainless steel in especially difficult environments.

### Powder Coat Finishes

To clean the powder coat finish, use a neutral detergent, such as a car shampoo, and rinse with clean water. In the event that the powder coat finish is chipped, and bare metal is showing, seal the area as soon as possible. If the area is not sealed, the underlying metal will rust, which could eat away the powder coat and cause flaking. Touch up paint is available from Alvarado.

### Acrylic Finishes

Use cleaning products that are specifically recommended for use on acrylic surfaces. We recommend two products:

- Brillianize
- Novus #1

The two recommended products will clean the material and leave a greaseless shine that will repel dust and resist fingerprints. DO NOT use scouring compounds or chemical cleaners like Windex that contain ammonia or alcohol. Using a soft cloth, clean the acrylic surfaces according to the instructions provided with the recommended cleaning product. DO NOT SCRUB THE ACRYLIC!



## Lubrication

It is recommended that the following lubricants be used when lubricating the MST turnstile.

Dow Corning  
MolyKote G-0010 Multipurpose Grease  
(-20° to +300°)

DuPont  
Teflon Non-Stick Dry-Film Lubricant (Bottle)  
(-100° to +480°)

**NOTE**

For installations in extreme cold locations, we recommend using Molykote 33 Extreme Application Grease (-100° to +400°) in lieu of the MolyKote G-0010.

Items/Points of Contact	Maintenance	Lubricant	Inspect Every...	Replace Every...
Lock Arms and Bolts	Check the lock arm(s) and the lock arm bolt(s). If the lock arm does not move freely, clean and oil the lock arm(s) and bolt(s). If the lock arm bolt is loose, apply a thread locking compound such as Blue Loctite to the threads, tighten and re-test. The lock arm should move freely, except for the pressure of the return spring.	DuPont Teflon Non-Stick Dry-Film Lubricant	6 Months	As required
Springs	Inspect and replace worn or damaged springs. Lubricate spring contact points using DuPont Teflon Non-Stick Dry-Film Lubricant with a tube extension applicator. <b>NOTE:</b> Use only Alvarado springs and only the springs designated for the location and use purpose. Turnstile springs are not interchangeable and should be used in designated locations only.	DuPont Teflon Non-Stick Dry-Film Lubricant	6 Months	1 years
Main Cam & Shaft Bearings	Lubricate the two grease fittings on the upper and lower top channel bearings using the recommended grease and a grease gun.	MolyKote G-0010 Multipurpose Grease	6 Months	As required
Solenoids	Clean the solenoid plunger and solenoid cavity area using alcohol wipes and alcohol moistened Q-tips. Apply a light coating of DuPont Teflon Non-Stick Dry-Film Lubricant on the solenoid plunger.	Alcohol / DuPont	6 Months	2 years
Optical Sensors	Clean & inspect the alignment of the optical sensors. To clean, an alcohol moistened Q-tip works well. The cam tag should rotate freely between the sensors and should travel at approximately 3/4 of the depth of the sensors. Loosen and adjust using the sensor mounting screws.	None	6 Months	As required
Electrical Wiring	Inspect all electrical wires and contacts for exposure to metal parts that may lead to a short.	None	6 Months	As required
Self-Centering Mechanism	Clean and lubricate the two slide rods using DuPont Teflon Non-Stick Dry-Film Lubricant with a tube extension applicator.	DuPont Teflon Non-Stick Dry-Film Lubricant	6 Months	As required

### Lock Arms and Bolts (Figure 34)

If the lock arm does not move freely, or is loose, detach the return spring from the lock arm and use a 5/16" Allen wrench to remove the lock arm bolt. Use DuPont Teflon Non-Stick Dry-Film Lubricant to lubricate the bushings on the top and bottom side of the lock arm. Apply blue Loctite thread locking compound to the lock arm mounting bolt. Tighten the bolt to a torque rating of 35 ft-lb. and check the lock arm for action. The lock arm should move freely, except for the pressure of the return spring.

If the lock arm mounting bolt is loose, follow the directions above, ensuring that blue Loctite thread locking compound is applied to the lock arm mounting bolt threads before re-installing the lock arm mounting bolt. After tightening the bolt the lock arm should move freely, except for the pressure of the return spring.

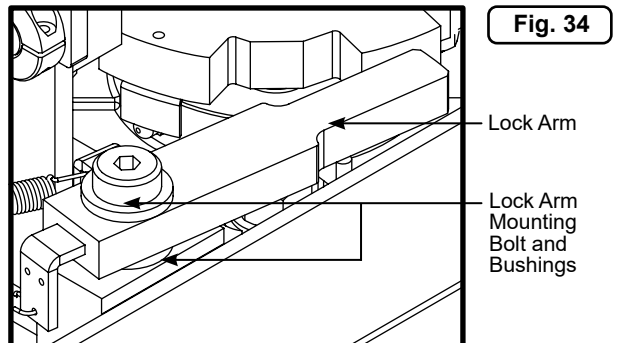

**Fig. 34**



### Lubrication (Cont)

#### Springs (Figure 35)

Lubricate spring contact points with DuPont Teflon Non-Stick Dry-Film Lubricant. Place lubricant on spring body by adding 1 drop on contact points.

Fig. 35

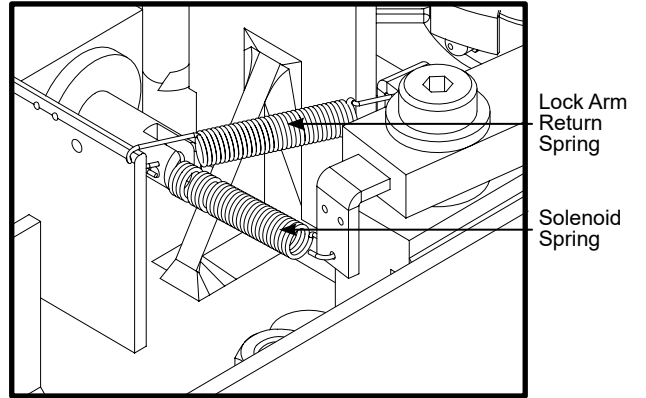

#### Main Cam and Upper Shaft Bearing (Figure 36)

Lubricate the grease fitting on the upper shaft bearing using the recommended grease and a grease gun.

Fig. 36

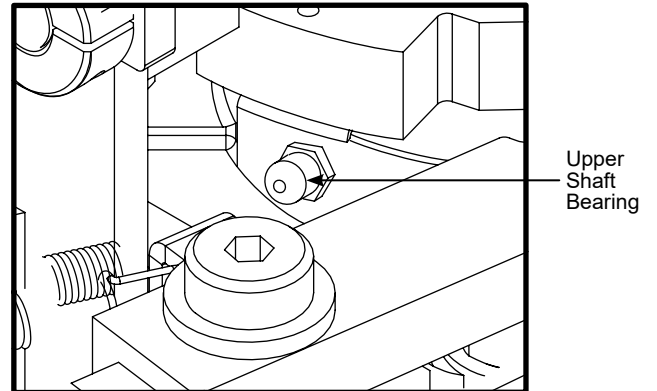

#### Main Cam and Lower Shaft Bearing (Figure 37)

Lubricate the grease fitting on the lower shaft bearing using the recommended grease and a grease gun.

Fig. 37

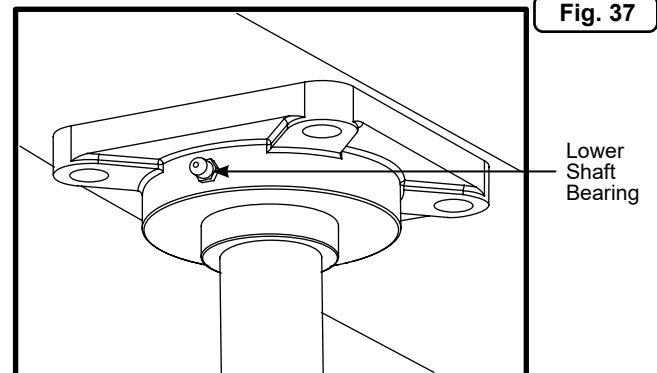

#### Self-Centering Mechanism (Figure 38)

Clean and lubricate the two slide rods using DuPont Teflon Non-Stick Dry-Film Lubricant. Place 2 to 3 drops of DuPont Teflon Non-Stick Dry-Film Lubricant along the shaft of the slide rods. Rotate the turnstile 4 to 5 times to ensure the lubricant is spread evenly along the slide rods.

Fig. 38

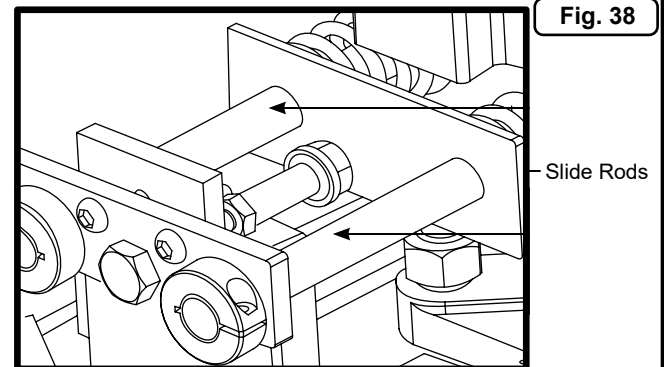



## Appendix A - CPST Installation

These instructions are for installing the yoke section of the CLST. When complete, please refer back to the "OV Installation" section.

### CPST Illustrated Parts List

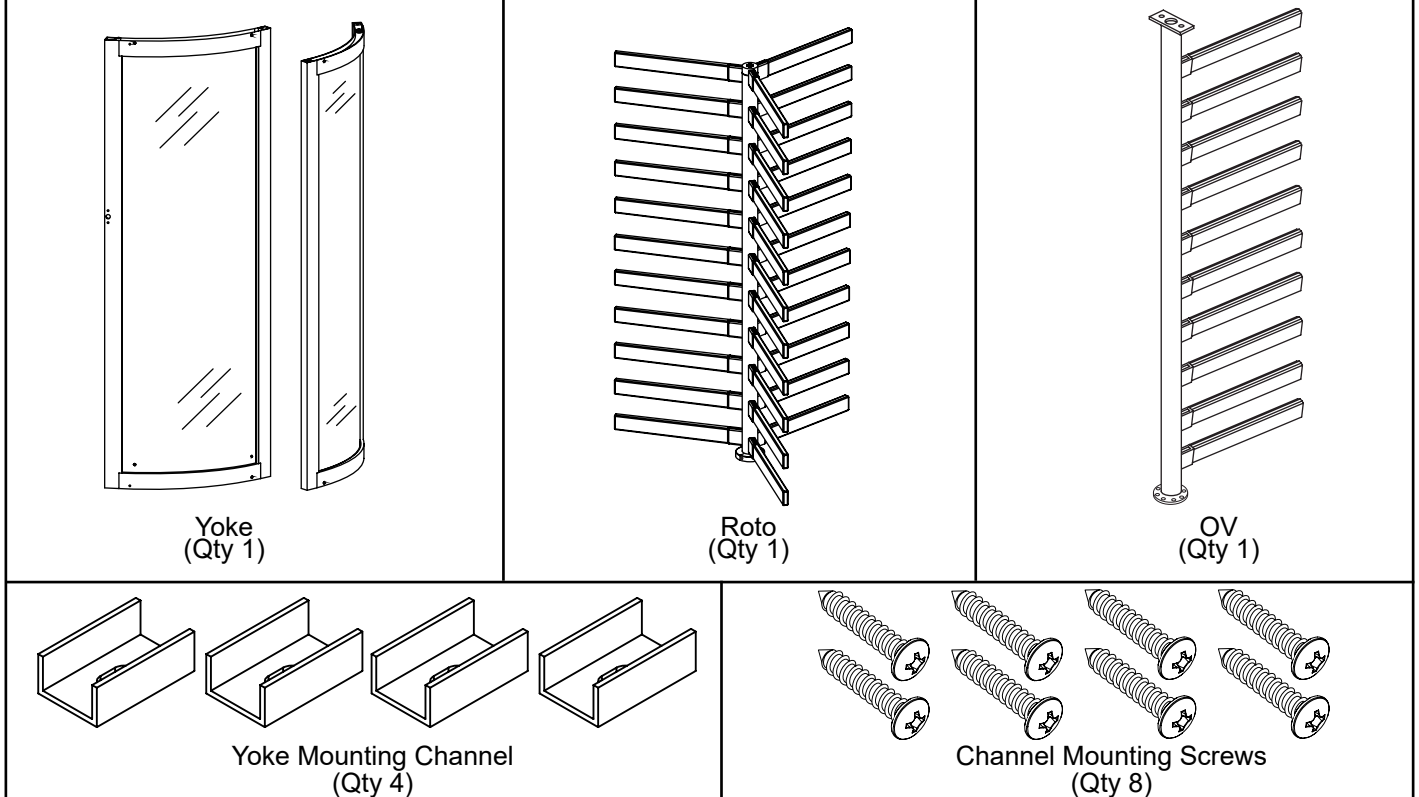

1. Determine where the turnstile will be installed. Consider the overall footprint size of the unit when determining the installation location (Figure A1). Once the installation location has been determined, use a chalk line to mark the centerline of the turnstile.

**Fig. A1**

Default entry rotation is counterclockwise. Confirm correct entry direction prior to installation.

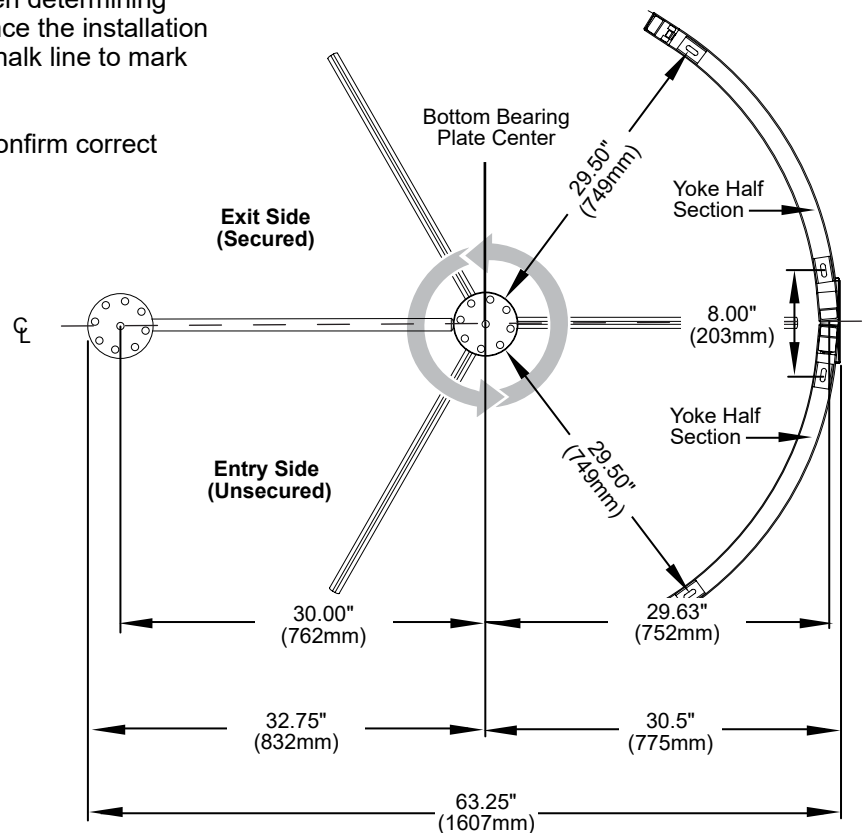

### NOTES

The overall height of the CPST is 91.5". However, an additional 3" of clearance must be added for service and maintenance.



### Yoke Installation

1. Determine the installation location for the yoke. Identify the threaded aluminum block at the top of each section. (Figure A1).
2. Push the two sections together (Figure A2).



#### NOTE

Prior to drilling the anchor bolt holes, use a tape measure and measure the distance from the bottom bearing plate center to the outer mounting holes on the two yoke sections (Figure A1). Adjust the yoke until these two distances are identical. Mark these two locations.

3. Use a pencil and trace the entire outline of the yoke assembly (Figure A3).
4. Locate the four (4) yoke mounting channels. Position the mounting channels within the traced outline, as noted in Step 3. All mounting channels should be placed 4" from each end of the two Yoke assemblies (Figure A4).

#### NOTE

The ground side of each yoke mounting channel should be facing outward.

5. Once the mounting channels are in place, mark each location (Figure A5).

Fig. A2

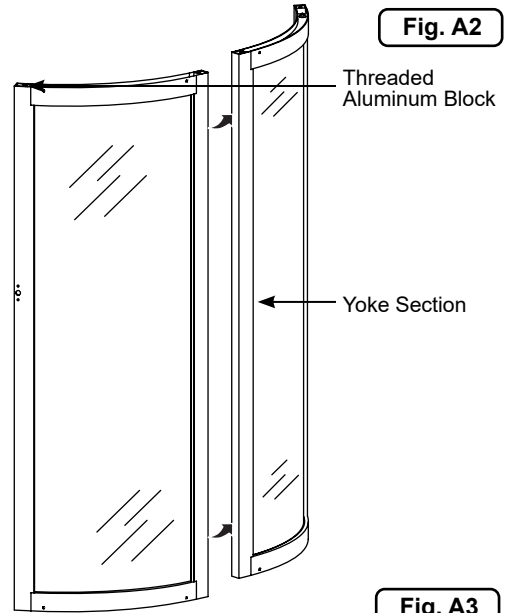

Fig. A3

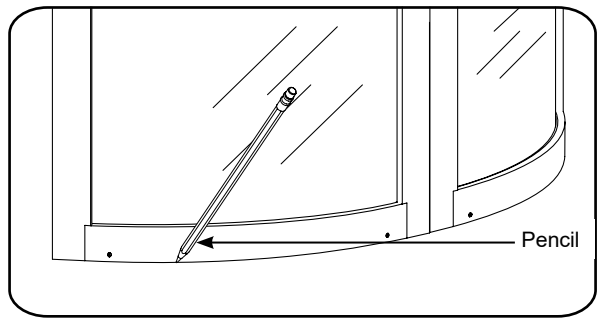

Fig. A5

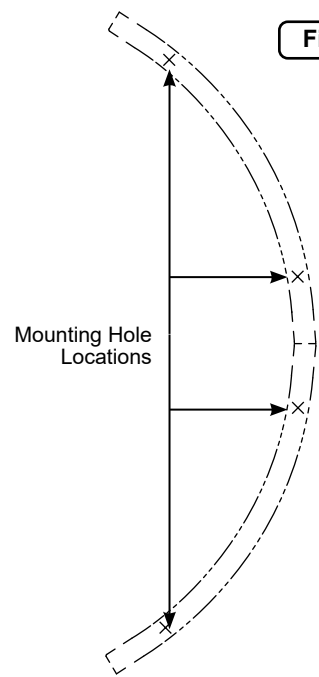
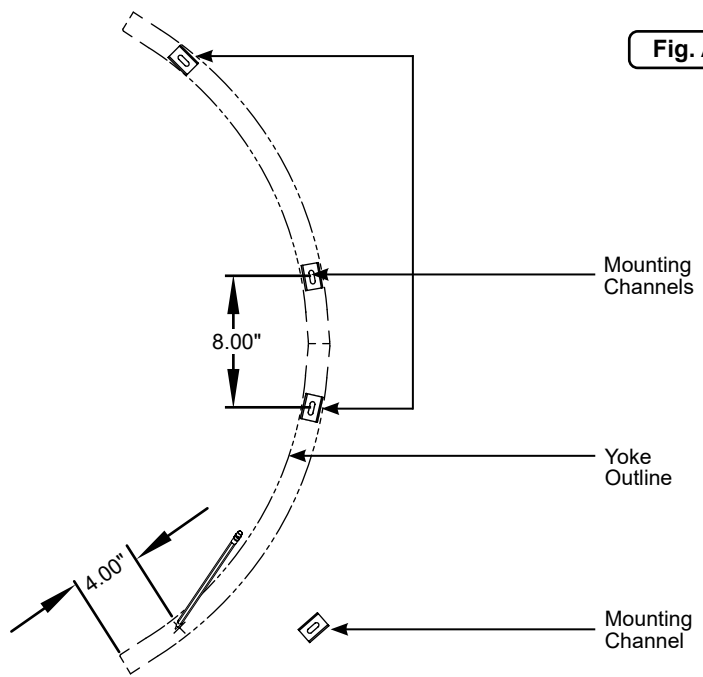

Fig. A4





## Yoke Installation (Cont)

- Using a  $\frac{5}{8}$ " concrete drill bit, drill an anchor hole 3" in depth (Figure A6). Repeat this step for the remaining mounting holes.

### NOTES

The anchor hole(s) must be clean before installing the anchor bolt(s). If the hole(s) are not clear of debris, the anchor bolt(s) may not tighten correctly.

- Insert one anchor into the drilled hole (Figure A6A). The threaded end of the anchor must be inserted into the hole first. Use a hammer to tap the anchor into place, if needed. Ensure that the anchor is flush with the concrete floor.
- Place one lower mounting channel over a mounting hole. Insert and tighten one  $\frac{3}{8}$ " x  $2\frac{1}{2}$ " anchor bolt and flat washer. Use a socket wrench and  $\frac{9}{16}$ " socket to tighten the bolts (Figure A7). Repeat this step for the remaining lower mounting channels and mounting hardware.
- Position the yoke assemblies over the mounting channels. Verify that the yoke assemblies are flush with each other. If the assemblies are flush with each other, then proceed to Step 10. If they are not, remove the yoke assemblies and realign the mounting channels.
- Use a torque wrench and tighten the anchor bolts to 40 ft-lbs.
- Place the yoke assemblies over the mounting channels
- Locate the two holes on the bottom of each yoke assembly. Secure each section to the mounting channel with a  $\frac{1}{4}$ -20 x 1" screw (Figure A8).

Once the yoke is installed and secured, please proceed to the "OV Installation" section.



Fig. A6

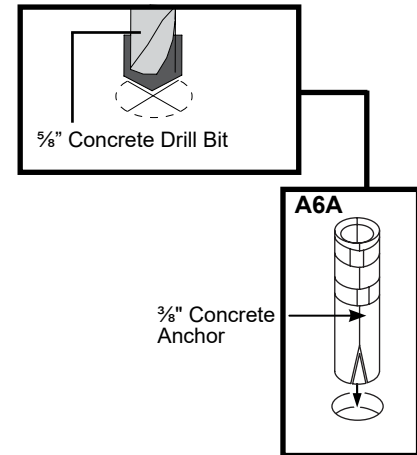

Fig. A7

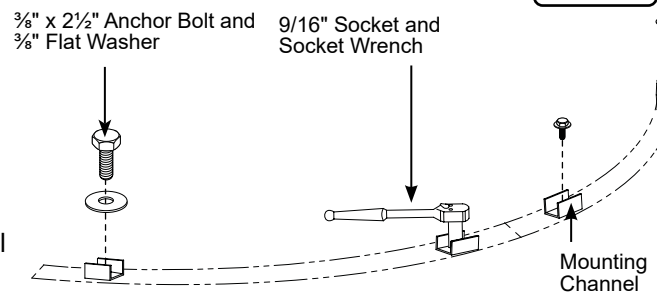
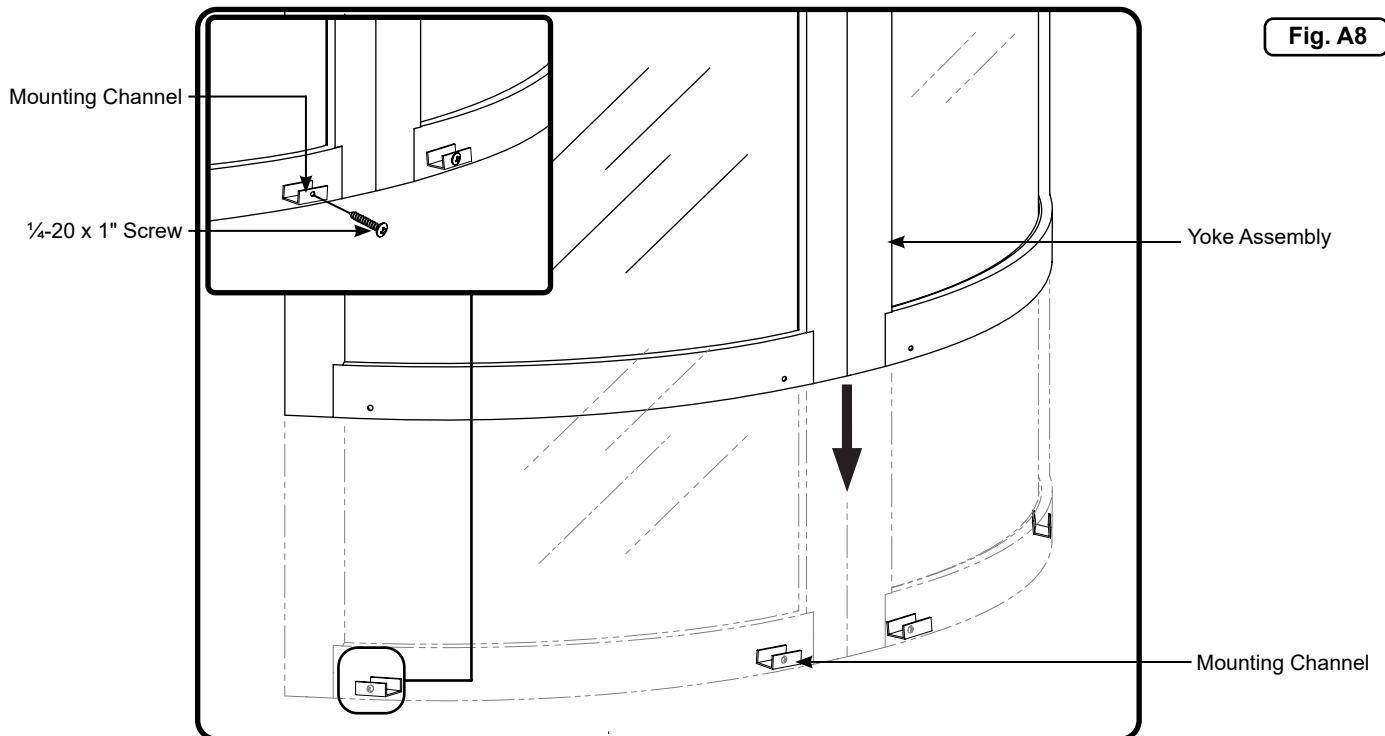

Fig. A8





### Appendix B - CLST Installation

These instructions are for installing the yoke section of the CLST. When complete, please refer back to the "OV Installation" section.

#### CLST Illustrated Parts List

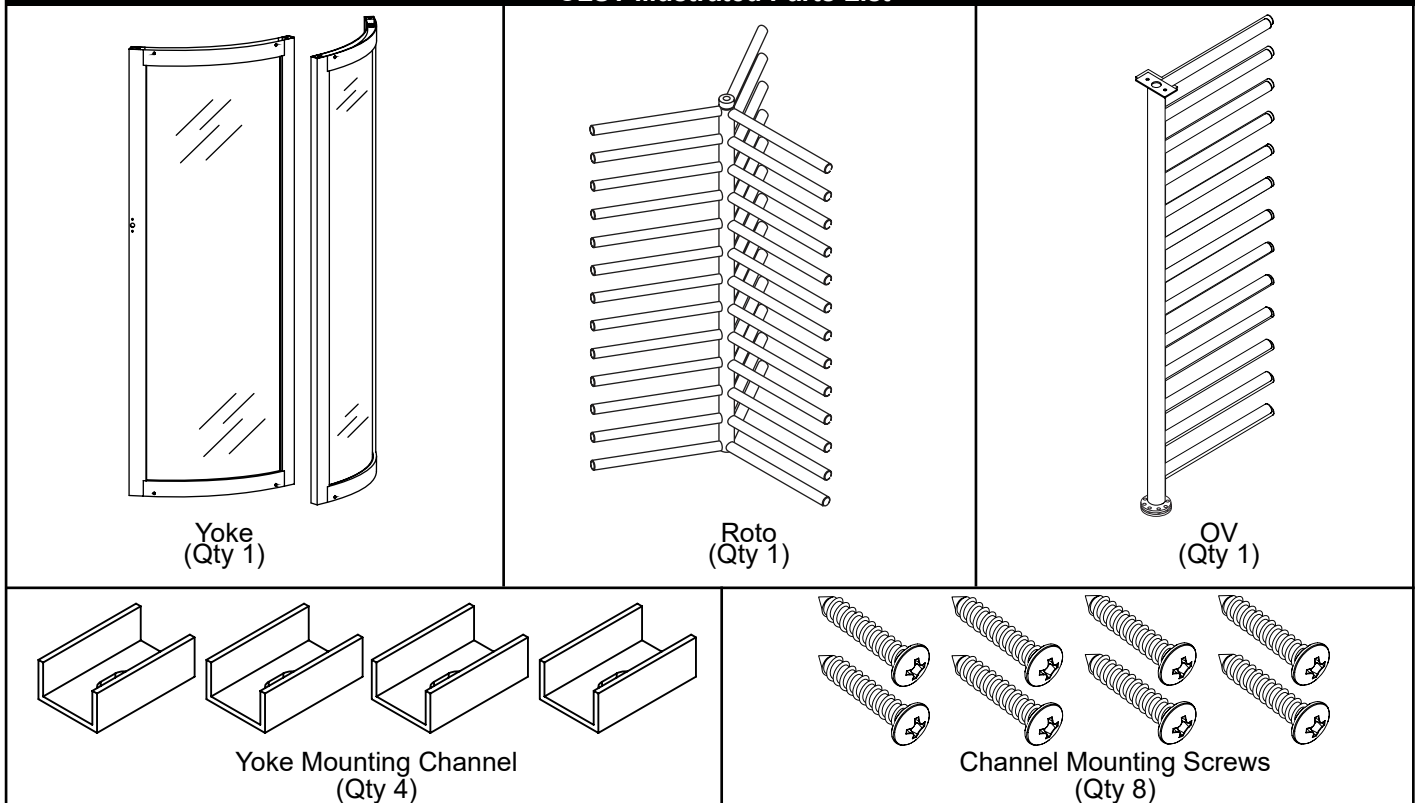

1. Determine where the turnstile will be installed. Consider the overall footprint size of the unit when determining the installation location (Figure B1). Once the installation location has been determined, use a chalk line to mark the centerline of the turnstile.

**Fig. B1**

Default entry rotation is counterclockwise. Confirm correct entry direction prior to installation.

#### Yoke Installation

Follow the steps shown in Appendix A (Figures A2 - A8). When complete, refer to the "OV Installation" to continue the installation.

#### NOTES

The overall height of the CLST is 91.5". However, an additional 3" of clearance must be added for service and maintenance.

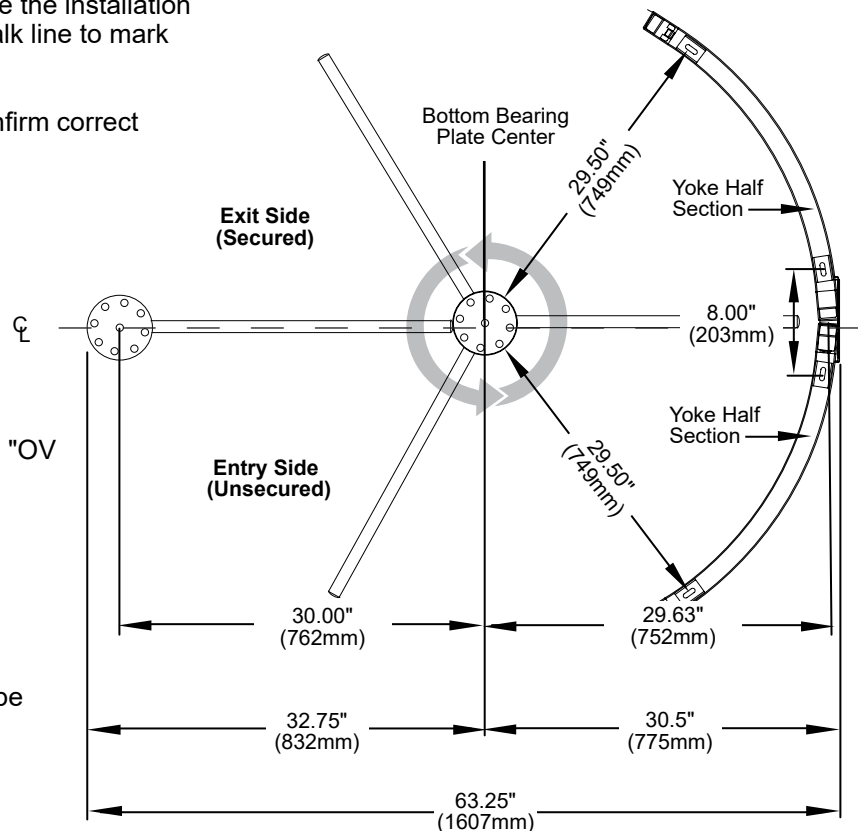



## Appendix C - FMST Installation

These instructions are for installing the yoke section of the FMST. When complete, please refer back to the "OV Installation" section.

### FMST Illustrated Parts List

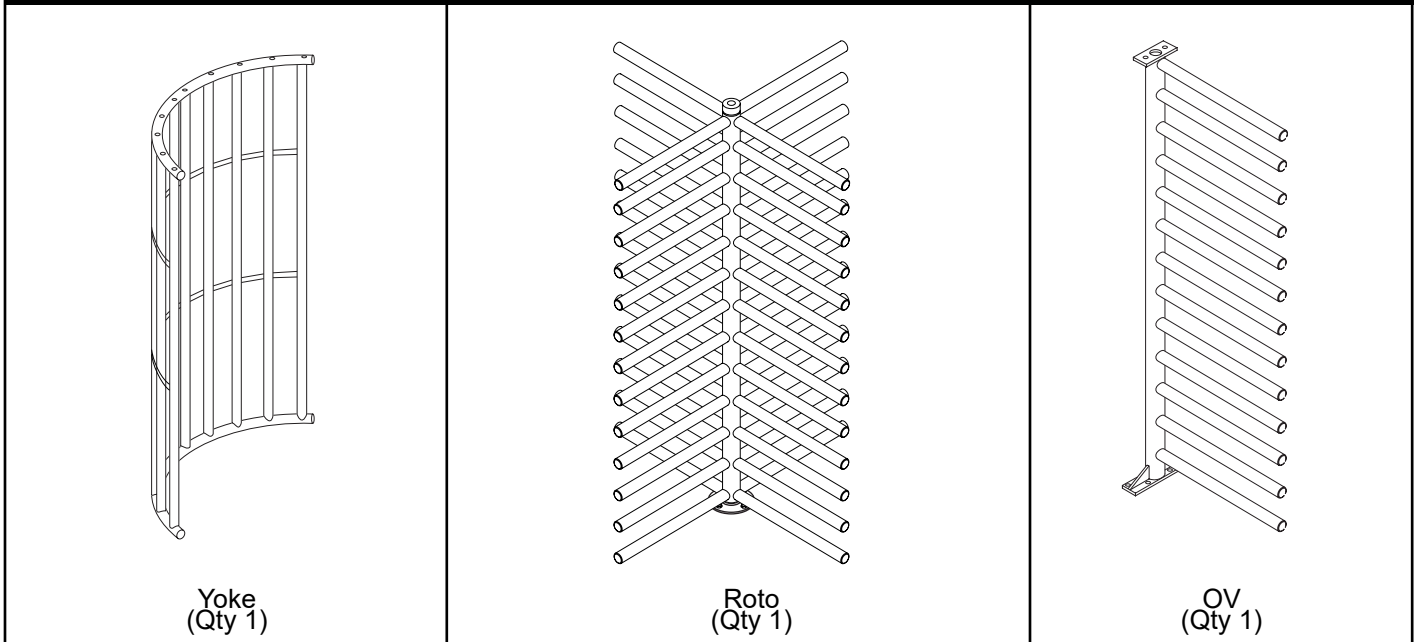

1. Determine where the turnstile will be installed. Consider the overall footprint size of the unit when determining the installation location (Figure C1). Once the installation location has been determined, use a chalk line to mark the centerline of the turnstile.

Default entry rotation is counterclockwise. Confirm correct entry direction prior to installation.

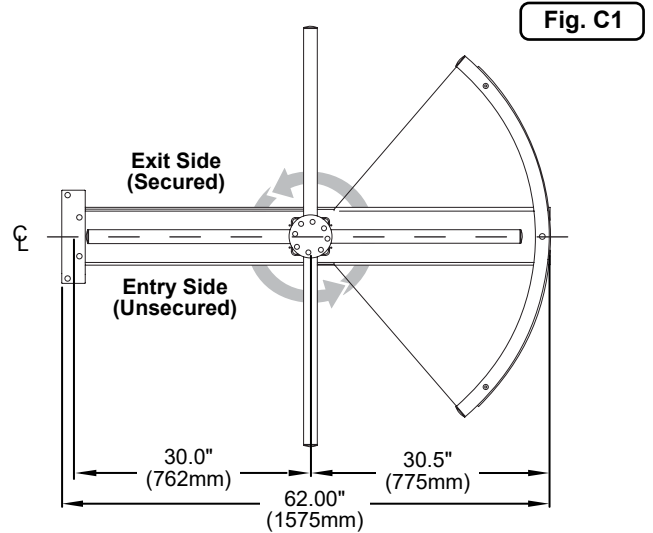

2. Reconfirm the centerline location for the yoke (Figure C2).
3. Continue installation as shown in the "Yoke Installation" section.

#### NOTES

The overall height of the FMST is 91.5". However, an additional 3" of clearance must be added for service and maintenance.

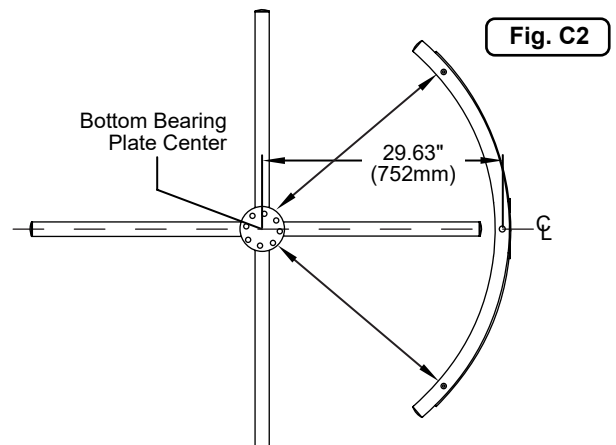



### Appendix D - MST47 Installation

These instructions are for installing the Yoke section of the MST47. When complete, please refer back to the "OV Installation" section.

#### MST47 Illustrated Parts List

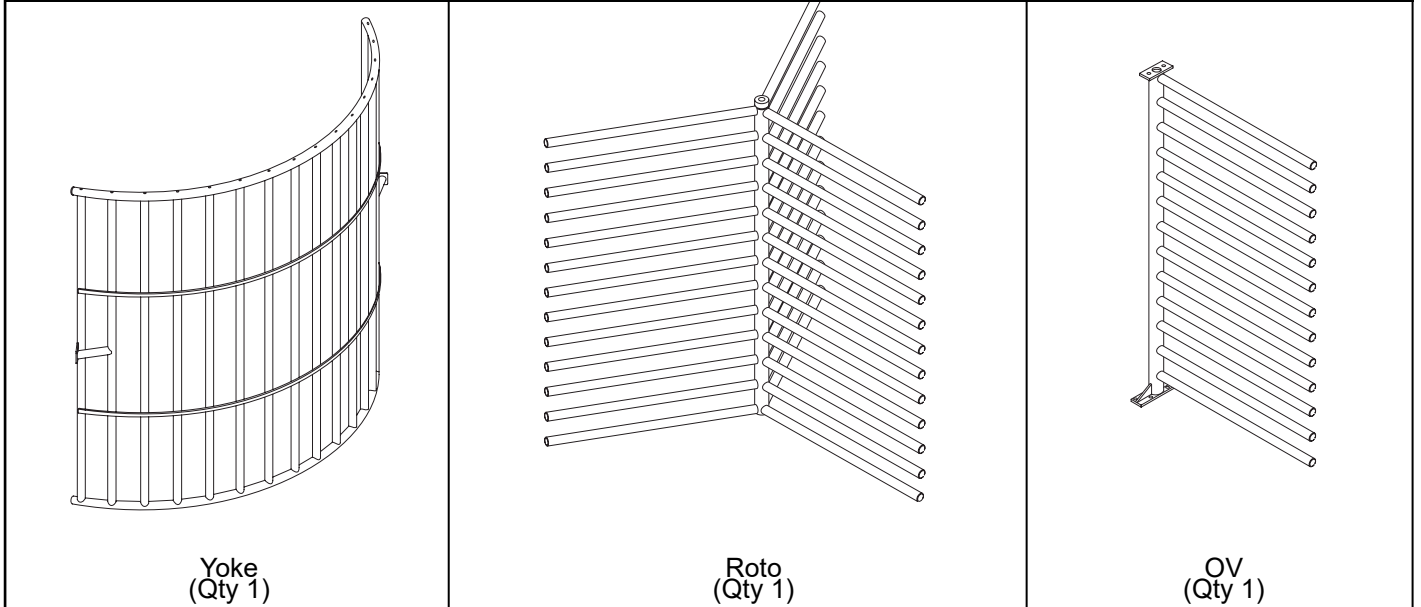

1. Determine where the turnstile will be installed. Consider the overall footprint size of the unit when determining the installation location (Figure D1). The slab requirement to install the MST47 is 10' x 8.5' x 4". Once the installation location has been determined, use a chalk line to mark the centerline of the turnstile.

**NOTE**

The overall height of the MST47 is 94". However, an additional 3" of clearance must be added for service and maintenance.

Default entry rotation is counterclockwise. Confirm correct entry direction prior to installation.

2. Reconfirm the centerline location for the Yoke (Figure D2).
3. Continue installation as shown in the "Yoke Installation" section.

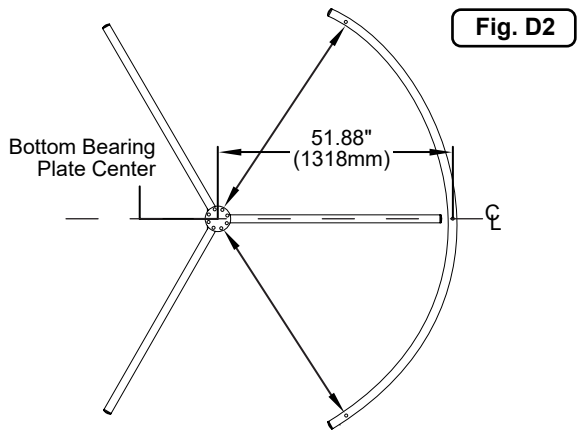
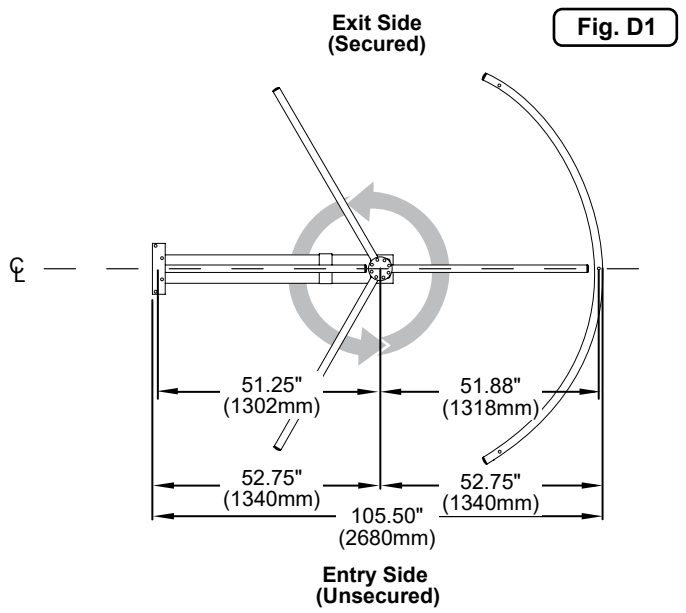



## Appendix E - Fail-lock / Fail-safe Spring and Solenoid Configurations

**Clockwise**

### Fail-lock / Fail-safe Spring and Solenoid Configurations - Adjustable Solenoid

**NOTE**

For use with turnstiles that utilize adjustable solenoid mounting positions.

**Fail-safe**

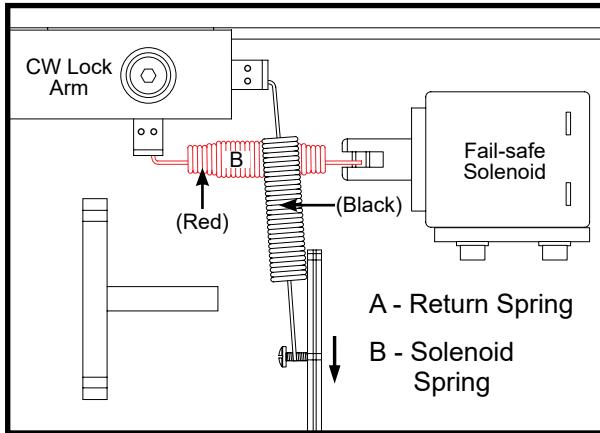

**Fail-lock**

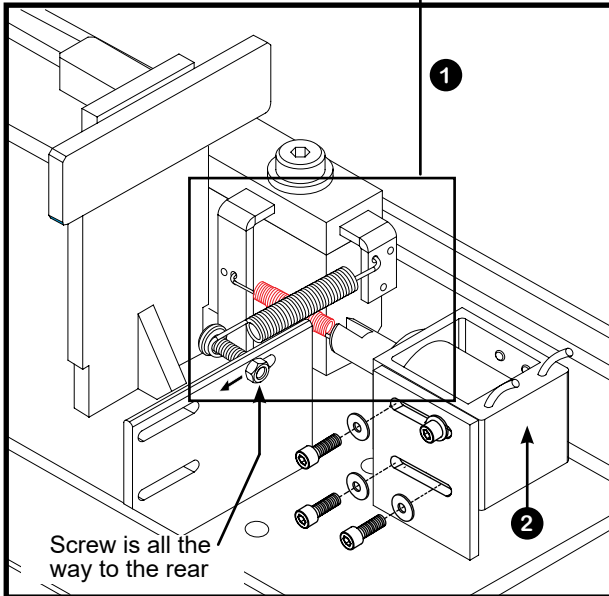
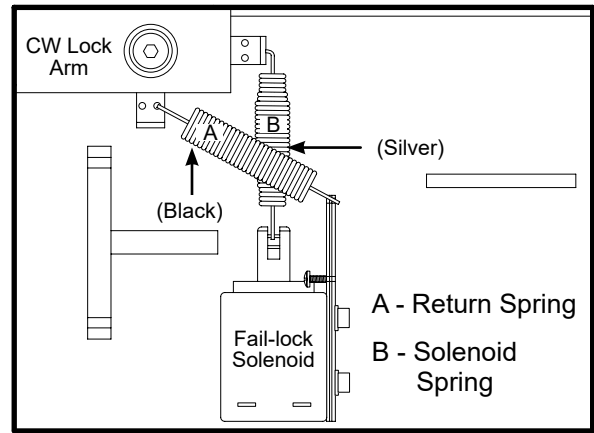

- 1 Spring Configuration
- 2 Solenoid Mount Position

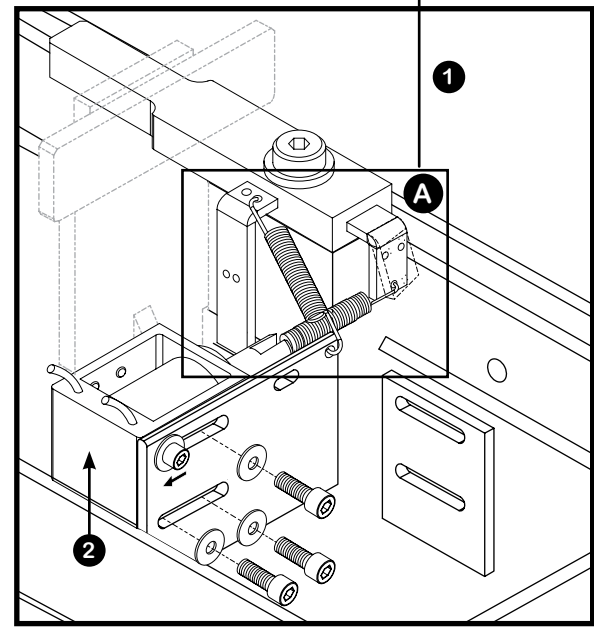

- 1 Spring Configuration
- 2 Solenoid Mount Position

**NOTES**

Spring & Solenoid Operations are contingent on the lock arm tabs being square to the lock arm body.

With exception to fail-lock clockwise (**A**), the solenoid will be mounted to the back of the slots. Then the lock arm tab will be used to adjust the spring tension (see illustration to the right).

Solenoid mounting screws must be tightened to 30 in-lbs. to avoid slippage from continuous use.

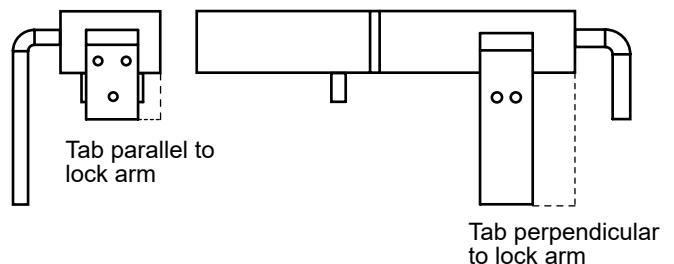



# Appendix E - Fail-lock / Fail-safe Spring and Solenoid Configurations (Cont)

## Counterclockwise

### Fail-lock / Fail-safe Spring and Solenoid Configurations - Adjustable Solenoid

**NOTE**

For use with turnstiles that utilize adjustable solenoid mounting positions.

#### Fail-safe

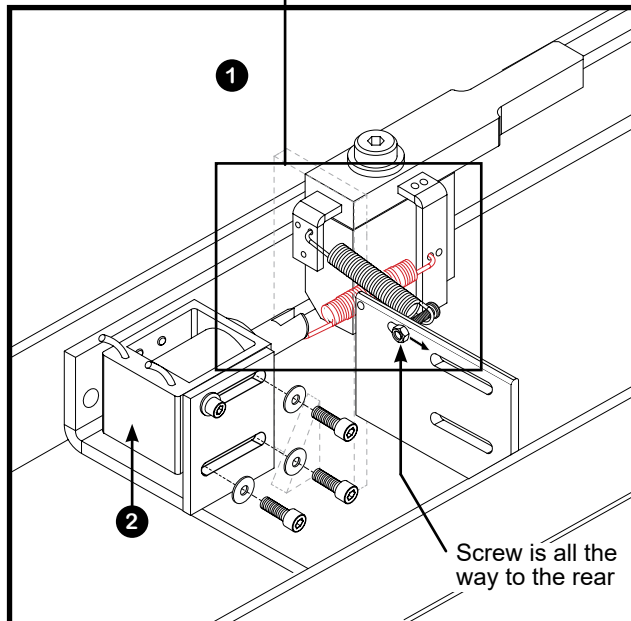
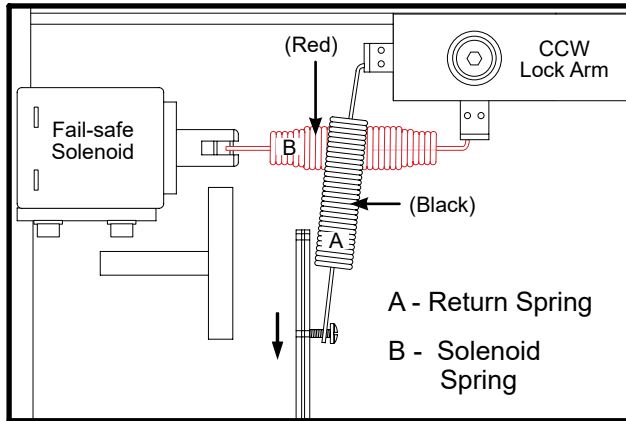

- 1 Spring Configuration
- 2 Solenoid Mount Position

**NOTE**

Spring & Solenoid Operations are contingent on the lock arm tabs being square to the lock arm body.

Solenoid mounting screws must be tightened to 30 in-lbs. to avoid slippage from continuous use.

#### Fail-lock

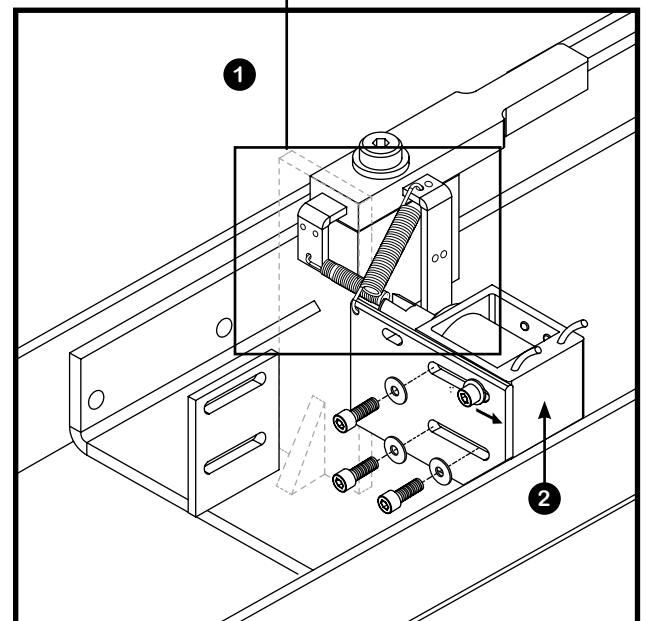
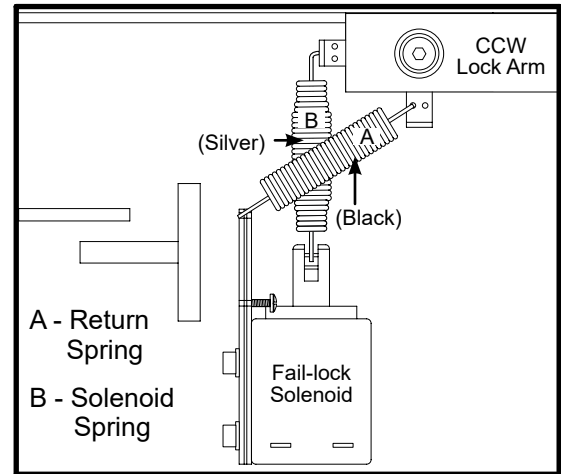

- 1 Spring Configuration
- 2 Solenoid Mount Position

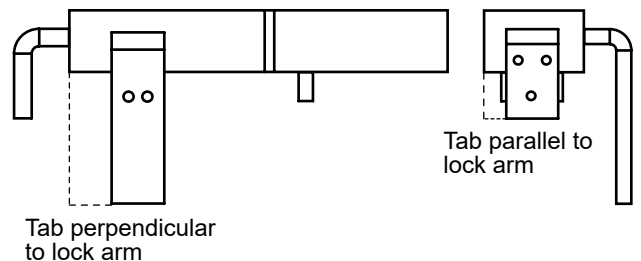



**Appendix E - Fail-lock / Fail-safe Spring and Solenoid Configurations (Cont)**

**Clockwise**

**Fail-lock / Fail-safe Spring and Solenoid Configurations - Fixed Solenoid**

**NOTE**

For use with turnstiles that utilize fixed solenoid mounting positions.

**Fail-safe**

**Fail-lock**

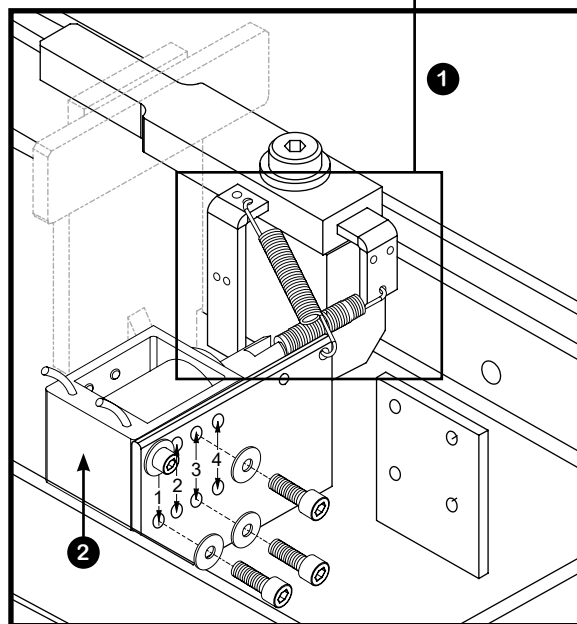
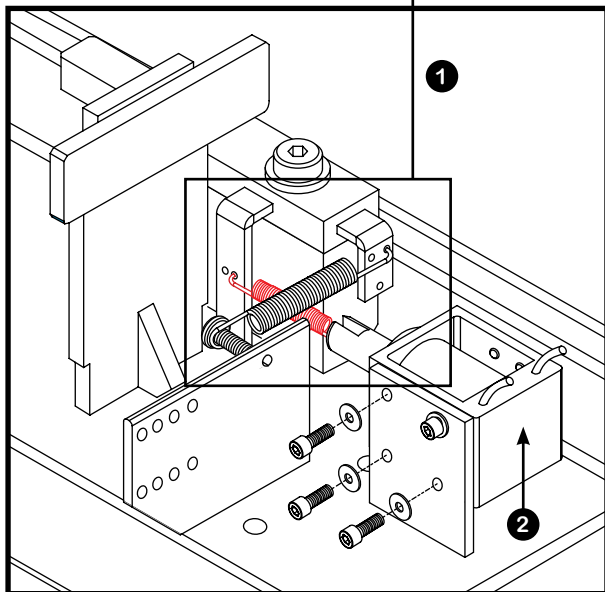
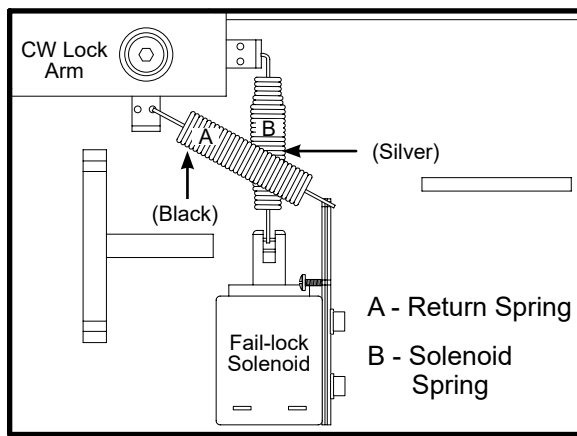
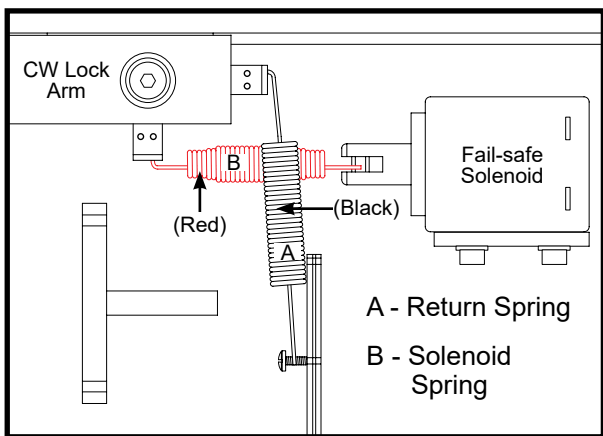

- ❶ Spring Configuration
- ❷ Solenoid Mount Position

- ❶ Spring Configuration
- ❷ Solenoid Mount Position (use holes 1 & 3)

**NOTES**

Bend lock arm tabs to mechanically adjust spring tension.  
Solenoid mounting screws must be tightened to 30 in-lbs. to avoid slippage from continuous use.

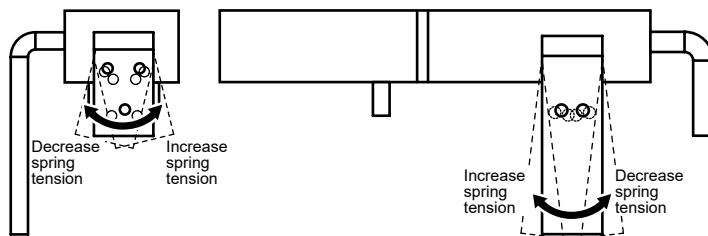



# Appendix E - Fail-lock / Fail-safe Spring and Solenoid Configurations (Cont)

Clockwise

## Fail-lock / Fail-safe Spring and Solenoid Configurations - Fixed Solenoid

**NOTE**

For use with turnstiles that utilize fixed solenoid mounting positions.

### Fail-safe

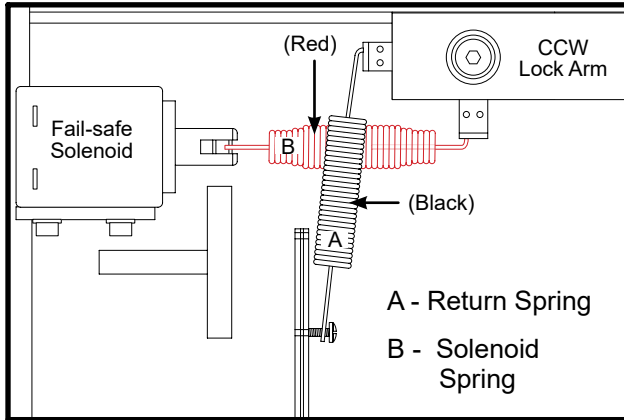

### Fail-lock

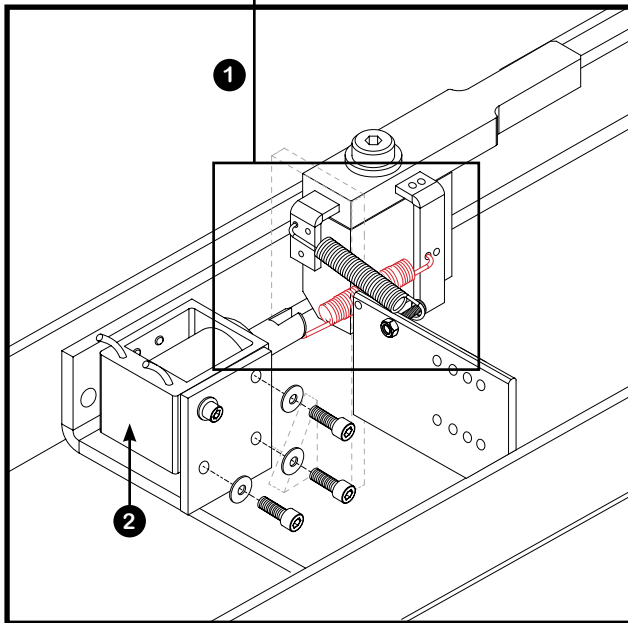
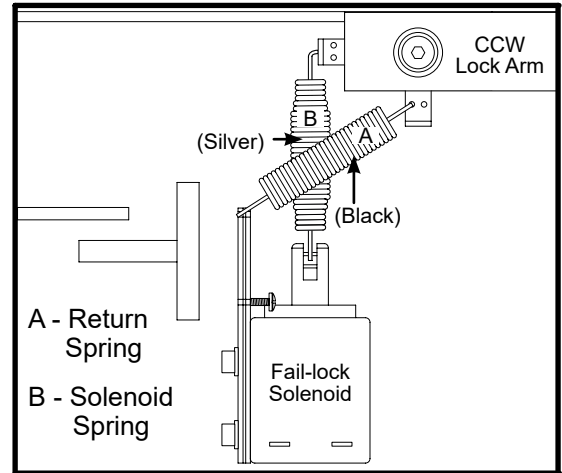

- 1 Spring Configuration
- 2 Solenoid Mount Position

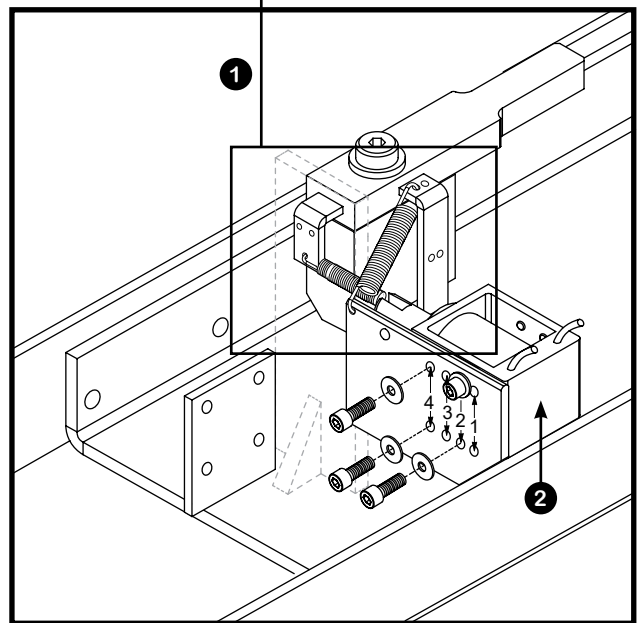

- 1 Spring Configuration
- 2 Solenoid Mount Position (use holes 2 & 4)

**NOTES**

Bend lock arm tabs to mechanically adjust spring tension.

Solenoid mounting screws must be tightened to 30 in-lbs. to avoid slippage from continuous use.

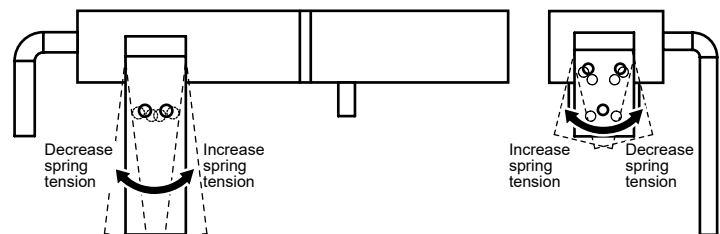



## Appendix F - Key Override Adjustable Cam Installation

### Clockwise

#### Removal / Installation

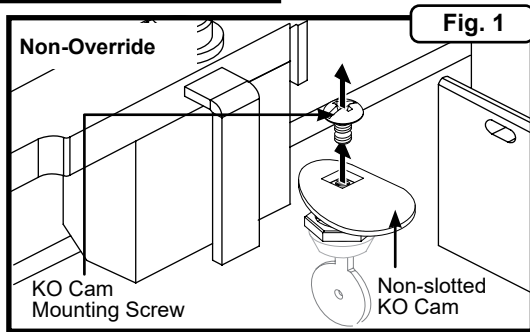

1. Rotate the key lock to the non-override position; then remove non-slotted key override (KO) cam (Figure 1).

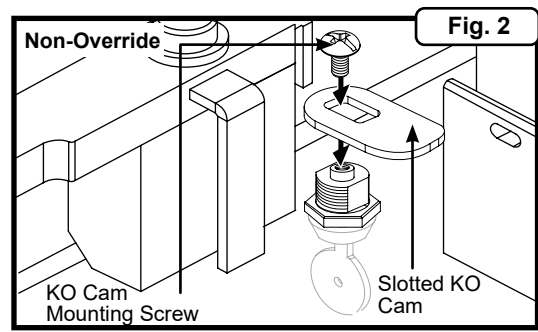

2. Install slotted KO cam. Do not fully tighten at this time (Figure 2).

**NOTE**

Add blue Loctite thread locking compound to the KO cam mounting screw.

#### Setup

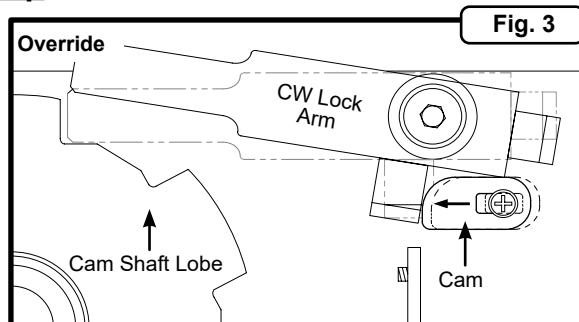

1. Hold CW lock arm open and rotate the key to the override position (Figure 3).
2. Slide cam to engage the lock arm tab securely and completely tighten the mounting screw.

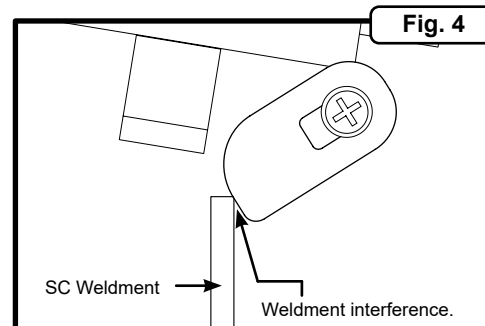

**NOTE**

The self-centering (SC) support weldment may interfere with cam rotation. Modification of SC weldment to clear interference may be required (Figure 4).

#### Test

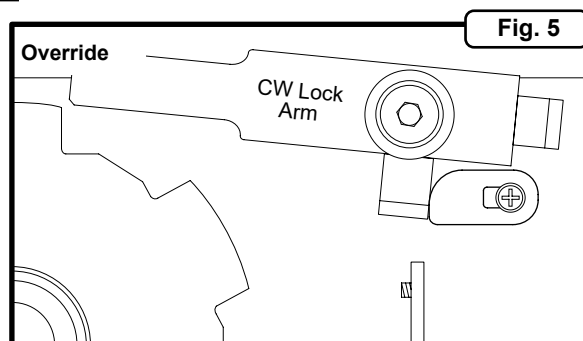

1. Rotate key to override position, verify lock arm clears cam shaft lobe and key is removable (Figure 5).

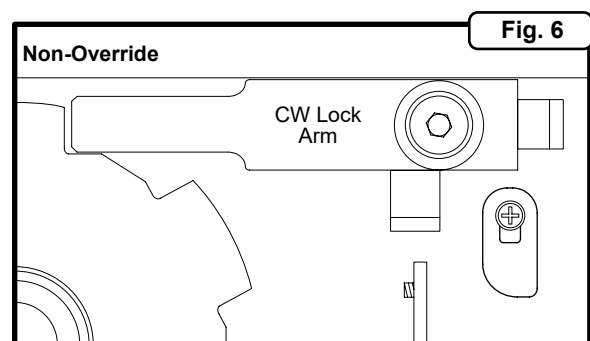

2. Rotate key back to non-override position, verify lock arm engages cam shaft lobe and key is removable (Figure 6).

**NOTE**

If key cannot be removed or lock arm does not clear or engage cam shaft lobe properly, repeat 'Setup' Step 1 and Step 2 to realign. If realignment does not solve the issue, contact Technical Support (800) 423-4143.



# Appendix F - Key Override Adjustable Cam Installation (Cont)

## Counterclockwise

### Removal / Installation

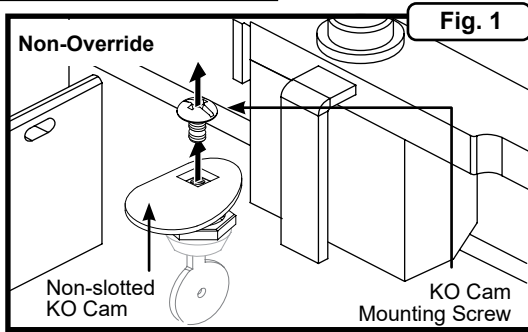

1. Rotate the key lock to the non-override position; then remove non-slotted key override (KO) cam (Figure 1).

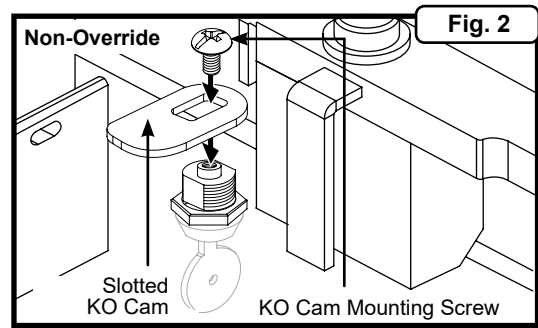

2. Install slotted KO cam. Do not fully tighten at this time (Figure 2).

**NOTE** Add blue Loctite thread locking compound to the KO cam mounting screw.

### Setup

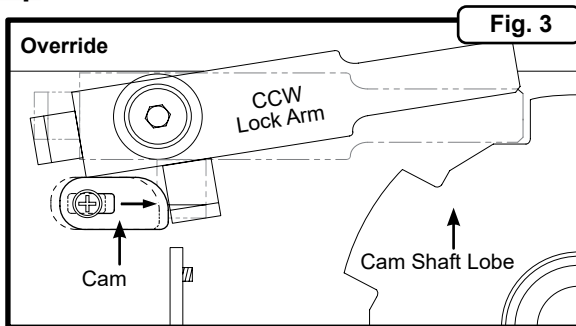

1. Hold CCW lock arm open and rotate the key to the override position (Figure 3).
2. Slide cam to engage the lock arm tab securely and completely tighten the mounting screw.

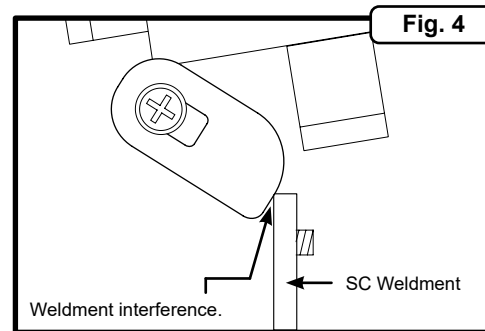

**NOTE** The self-centering (SC) support weldment may interfere with cam rotation. Modification of SC weldment to clear interference may be required (Figure 4).

### Test

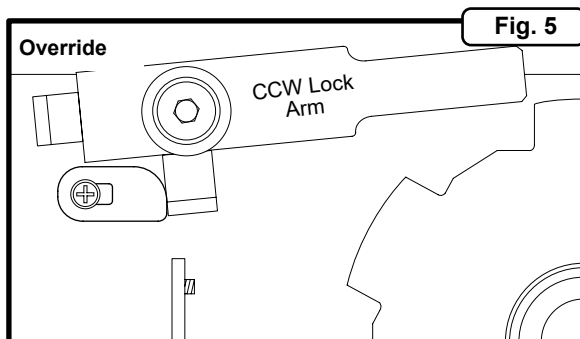

1. Rotate key to override position, verify lock arm clears cam shaft lobe and key is removable (Figure 5).

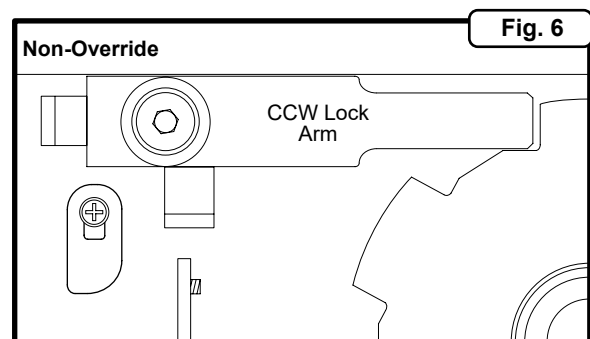

2. Rotate key back to non-override position, verify lock arm engages cam shaft lobe and key is removable (Figure 6).

**NOTE** If key cannot be removed or lock arm does not clear or engage cam shaft lobe properly, repeat 'Setup' Step 1 and Step 2 to realign. If realignment does not solve the issue, contact Technical Support (800) 423-4143.

**Revision History**

Revision	Date	Author	Description
6-0	10/16/2014	A. Flores	Added fire alarm system connection to turnstile control board section.
6-1	11/6/2015	A. Flores	SW4 DIP switch 8 configures OPN inputs as either normally open (N.O.) or normally closed (N.C.).  Replaced Tri-Flow Lubricant with DuPont Teflon Non-Stick Dry-Film Lubricant.  Acrylic finish care instructions added to Cleaning and Maintenance section.
6-2	10/20/2016	A. Flores	UL 294, UL 325, and CSA C22.2 NO.247-14 Certifications



**Alvarado Manufacturing Company, Inc.**

12660 Colony Street, Chino, CA 91710

Toll Free: (800) 423-4143

Fax: (909) 628-1403

[information@alvaradomfg.com](mailto:information@alvaradomfg.com)

[www.alvaradomfg.com](http://www.alvaradomfg.com)