

MV-CH250-20XM/XC

25 MP CMOS CoaXPress Area Scan Camera



GEN<i>i</i>CAM

Introduction

MV-CH250-20XM/XC camera adopts OnSemi Python25K sensor to provide high-quality image. It uses CXP-6 interface to transmit non-compressed images in real time, and its max. frame rate can reach 79.9 fps in full resolution.

Key Feature

- Resolution of 5120 × 5120, pixel size of 4.5 μm × 4.5 μm.
- Supports binning, reversing image, etc.
- Adopts global shutter CMOS to provide high dynamic range, SNR, and high-quality images.
- Adopts CXP-6 interface to transmit data.
- Compatible with CoaXPress Protocol and GenICam Standard, and third-party software based on the protocol and standard.

Available Model

- Mono camera: MV-CH250-20XM-M58S-NN
- Color camera: MV-CH250-20XC-M58S-NN

Applicable Industry

Electronics, semiconductor, PCB AOI, 3D application, motion capture, etc.

Sensor Quantum Efficiency

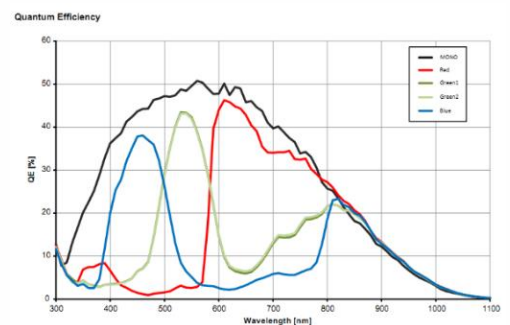

Dimension

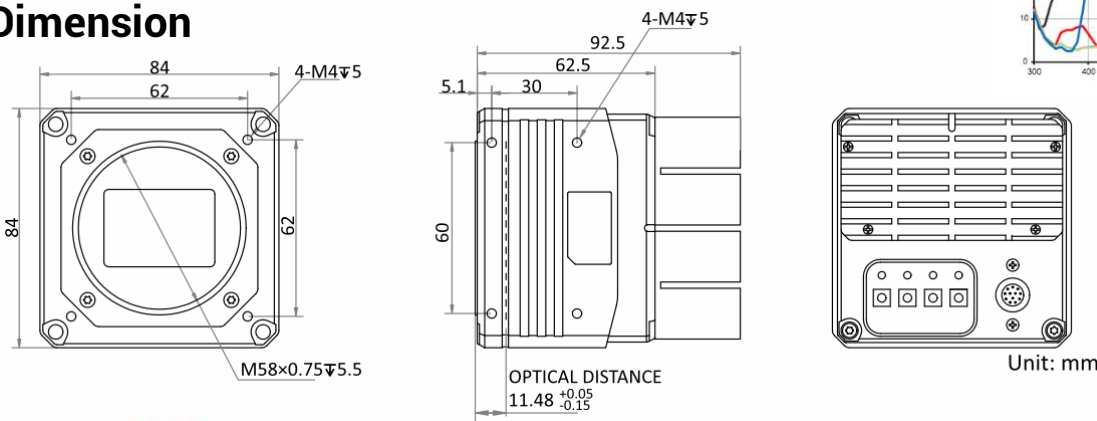

Specification

Model	MV-CH250-20XM	MV-CH250-20XC
Camera		
Sensor type	CMOS, global shutter	
Sensor model	OnSemi Python25K	
Pixel size	4.5 μm × 4.5 μm	
Sensor size	23 mm × 23 mm	
Resolution	5120 × 5120	
Max. frame rate	79.9 fps @5120 × 5120	
Dynamic range	58 dB	
SNR	41 dB	
Gain	0 dB to 15 dB	
Exposure time	33 μs to 10 sec	
Exposure mode	Off/Once/Continuous exposure mode	
Mono/color	Mono	Color
Pixel format	Mono 8/10/12	Bayer RG 8/10/12
Binning	Supports 1 × 1, 1 × 2, 1 × 4, 2 × 1, 2 × 2, 2 × 4, 4 × 1, 4 × 2, 4 × 4	
Decimation	Supports 1 × 1, 1 × 2, 1 × 4, 2 × 1, 2 × 2, 2 × 4, 4 × 1, 4 × 2, 4 × 4	
Reverse image	Supports horizontal and vertical reverse image output	
Electrical features		
Data interface	CoaXPress with DIN interface	
Digital I/O	12-pin P10 connector provides power and I/O, including opto-isolated input × 1 (Line 0), opto-isolated output × 1 (Line 1), bi-directional non-isolated I/O × 1 (Line 2), and RS-232 × 1.	
Power supply	9 VDC to 24 VDC, CXP-0 and CXP-1 connectors support PoCXP	
Power consumption	Typ. 10.8 W@24 VDC	Typ. 10.5 W@24 VDC
Mechanical		
Lens mount	M58-mount, optical back focal length 11.48 mm (0.5")	
Dimension	84 mm × 84 mm × 62.5 mm (3.3" × 3.3" × 2.5")	
Weight	Approx. 730 g (1.6 lb.)	
Ingress protection	IP40 (under proper lens installation and wiring)	
Temperature	Working temperature: 0 °C to 50 °C (32 °F to 122 °F) Storage temperature: -30 °C to 70 °C (-22 °F to 158 °F)	
Humidity	20% to 95% RH, non-condensing	
General		
Client software	MVS or frame grabber software meeting with CoaXPress Protocol	
Operating system	32/64-bit Windows 7/10	
Compatibility	CoaXPress, GenICam	
Certification	CE, RoHS, KC	

HIKROBOT

Hangzhou Hikrobot Co., Ltd.
en.hikrobotics.com

© Hangzhou Hikrobot Co., Ltd. All Rights Reserved.

Hangzhou Hikrobot does not tolerate any infringement. Any organization or individual may not imitate or reproduce in whole or in part of the content. The data herein is based on Hikrobot's internal evaluation. Actual data may vary depending on specific configuration and operating condition. The information herein is subject to change without notice. All the content has been checked conscientiously. Nevertheless, Hikrobot shall not be liable to damages resulting from errors, inconsistencies or omissions.